

# OUTDOOR PARETI MOBILI

PARETI MOBILI  
SLIDING WALLS  
SCHIEBEWÄNDE

C



07/2021

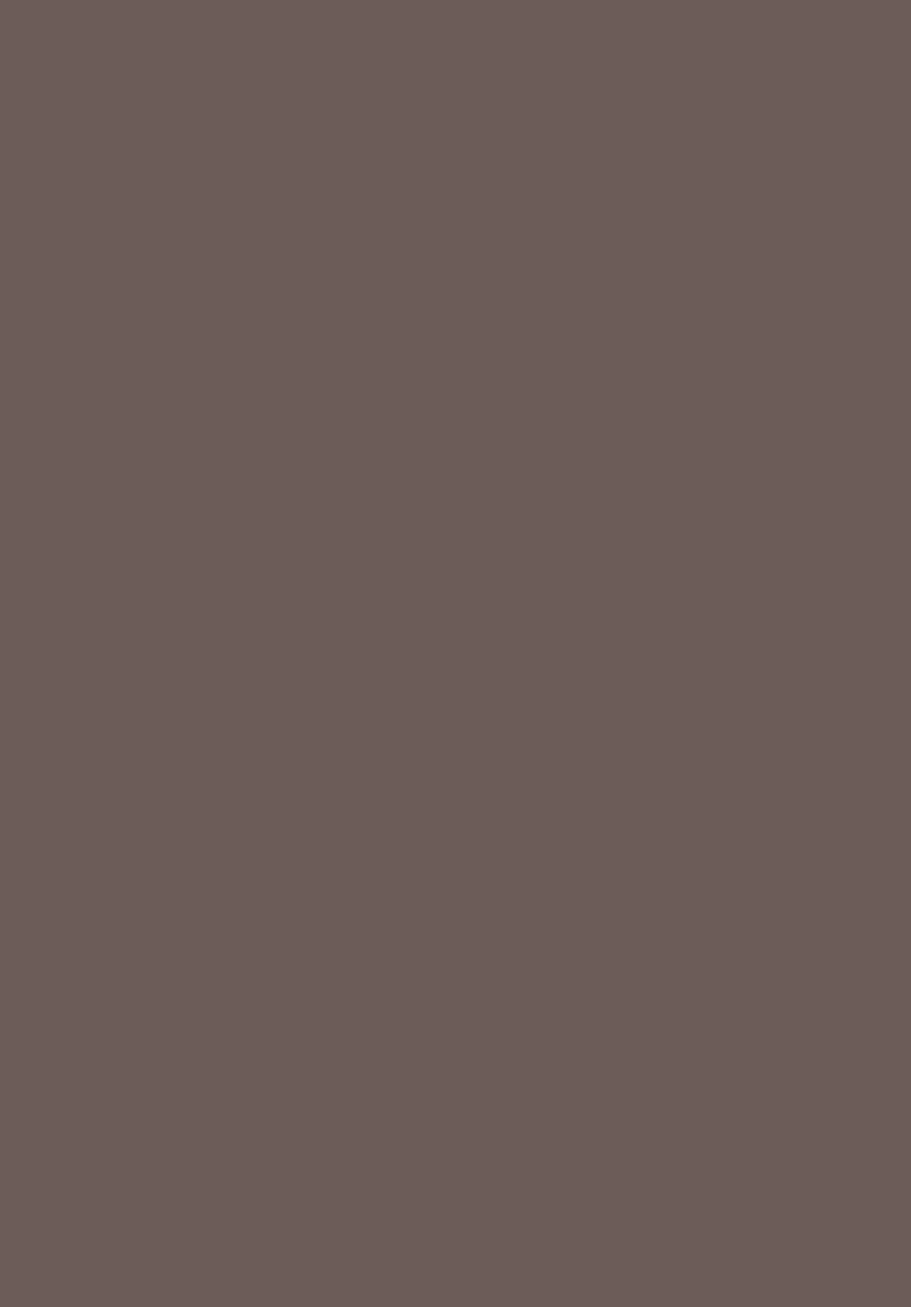

# OUTDOOR PARETI MOBILI

INDICE / INDEX / INHALT



I NUOVI CATALOGHI METALGLAS BONOMI E I NUOVI LISTINI .....	2
<i>THE NEW CATALOGS METALGLAS BONOMI AND NEW PRICE LISTS</i>	
<i>DIE NEUEN KATALOGE METALGLAS BONOMI UND NEUE PREISLISTEN</i>	
DAL CATALOGO AL LISTINO CON UN SEMPLICE CODICE .....	4
<i>FROM THE CATALOG TO THE LIST WITH A SIMPLE CODE</i>	
<i>VOM KATALOG ZUR LISTE MIT EINEM EINFACHEN CODE</i>	
LEGENDA SIMBOLI .....	6
<i>SYMBOL LEGEND</i>	
<i>SYMBOLLEGENDE</i>	
LEGENDA ABBREVIAZIONI .....	7
<i>ACRONYM LEGEND</i>	
<i>ERKLÄRUNG DER ABKÜRZUNGEN</i>	
FINITURE .....	7
<i>FINISHES</i>	
<i>ÖBERFLÄCHEN</i>	
MYMETALGLAS .....	8
<i>MYMETALGLAS</i>	
<i>MYMETALGLAS</i>	
<hr/>	
<b>C</b>   PARETI MOBILI .....	12
<i>SLIDING WALLS</i>	
<i>SCHIEBEWÄNDE</i>	
GUIDA TECNICA PER LA SCELTA DEL VOSTRO SISTEMA .....	16
<i>TECHNICAL GUIDE FOR THE CHOICE OF YOUR SYSTEM</i>	
<i>AUSWAHL VON SYSTEME NACH VORHANDENEN KRITERIEN</i>	

# I NUOVI CATALOGHI METALGLAS BONOMI

THE NEW CATALOGS METALGLAS BONOMI  
DIE NEUEN KATALOGE METALGLAS BONOMI



## SCORREVOLI

**A** | SISTEMI SCORREVOLI  
SLIDING DOOR SYSTEMS  
SCHIEBETÜRSYSTEME



## BOX DOCCIA

**B** | BOX DOCCIA  
SHOWER BOX  
DUSCHKABINEN



## OUTDOOR PARETI MOBILI

**C** | PARETI MOBILI  
SLIDING WALLS  
SCHIEBEWÄNDE

# ... E I NUOVI LISTINI PREZZI

... AND NEW PRICE LISTS  
... UND NEUE PREISLISTEN

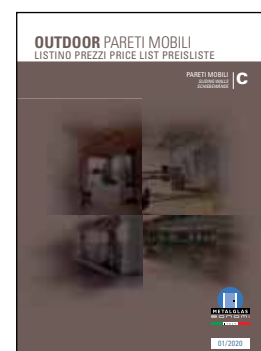
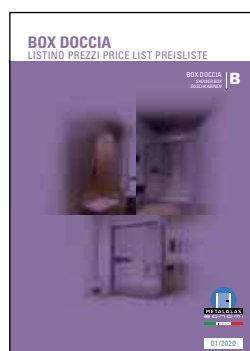



## INDOOR

- D** | PARETI DIVISORIE E STIPITI  
PARTITION WALLS AND FRAMES  
TRENNWÄNDE UND ALUMINIUMZARGEN
- E** | SERRATURE E CERNIERE  
LOCKS AND HINGES  
SCHLÖSSER UND BÄNDER
- F** | MANIGLIE MANIGLIONI POMOLI  
DOORHANDLES PULLHANDLES KNOBS  
TÜRGRIFFE STOSSGRIFFE KNÖPFE
- G** | PORTE ESTERNE  
PATCH FITTINGS  
GANZGLASANLAGEN

## OUTDOOR BALAUSTR E PENSILINE

- H** | BALAUSTR E PENSILINE  
RAILING AND CANOPY SYSTEMS  
GANZGLASGELÄNDER UND VORDACHSYSTEME
- I** | DISTANZIALI MORSETTI ACCESSORI  
POINT FITTINGS CLAMPS ACCESSORIES  
PUNKTHALTERUNG KLEMMBEFESTIGUNGEN ZUBEHÖRE

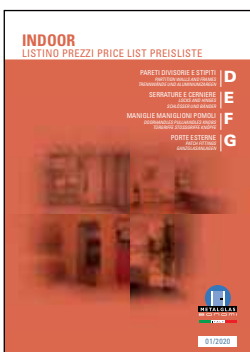

# DAL CATALOGO AL LISTINO CON UN SEMPLICE CODICE

FROM THE CATALOG TO THE LIST WITH A SIMPLE CODE  
VOM KATALOG ZUR LISTE MIT EINEM EINFACHEN CODE

SEARCH FOR THE CODE  
OF EVERY PRODUCT IN  
CATALOG...

SUCHE NACH DEM CODE  
VON JEDEM PRODUKT IN  
KATALOG ...

**(ERCA IL CODICE  
DI OGNI PRODOTTO NEL  
CATALOGO...**

MOBILI  
BEWÄNDE

LINE 1

SLIDING STACKING SYSTEMS / GANZGLAS-SCHIEBEWÄNDE

OUTDOOR PARETI MOBILI | **C**  
SLIDING WALLS | SCHIEBEWÄNDE

**METALGLAS**

€ ▶ **C.01**



10-12-127	1250	3900
Porta laterale Lateral door Dreh-Erdfüßel		
550 min 1250 max		

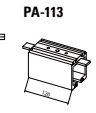
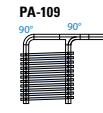
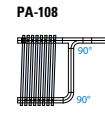
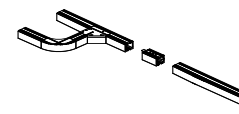
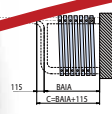

- Baie da ordinare a parte oltre alle ante, altre baie disponibili da pag. 54
- To be ordered separately from the panels, other parking bays available from page 54
- Neben den Flügel extra zu bestellen, andere Parkräume

**OUTDOOR PARETI MOBILI**

PARETI MOBILI | **C**  
SLIDING WALLS | SCHIEBEWÄNDE

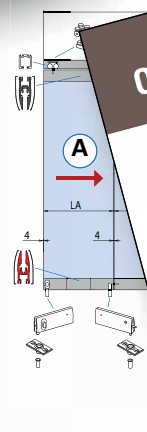
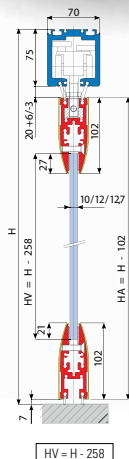

**AN** Alluminio anodizzato  
Aluminium anodized  
Aluminium Silberfarbig

**At** Aline totali  
Total clearances  
Summe alle Abstände Glas

vetro  
lamin glass  
Sicherung



01/2020

## OUTDOOR

**PA-200**
**Scorrevoli a parcheggio**
**C.01**

- Set compresi di binario, pannello e profilo
- Set with panel profiles, rail and glass
- Set mit Flügelprofile, Laufwerk und Glas

**PA-200 SET 3** 3 panels AN € 4.181,00

**PA-108 / PA-109** AN € 1.065,00

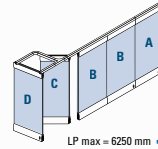
**PA-200 SET 5** 5 panels AN € 5.158,00  
**PA-108 / PA-109** AN € 1.065,00  
**Tot. € 6.223,00**

LP max = 6250 mm

**PA-200 SET 8** 8 panels AN € 8.183,00

**PA-108 / PA-109** AN € 1.065,00

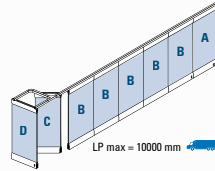
**Tot. € 9.248,00**

LP max = 10000 mm

**PA-200 SET 9** 9 panels AN € 8.985,00

**PA-108 / PA-109** AN € 1.065,00

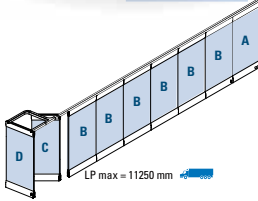
**Tot. € 10.050,00**

LP max = 11250 mm

**PA-200 SET 10** 10 panels AN € 9.463,00

**PA-108 / PA-109** AN € 1.065,00

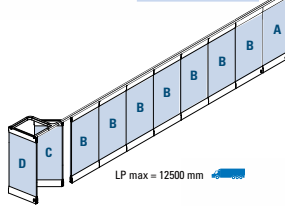
**Tot. € 10.528,00**

LP max = 12500 mm

- Indicare sempre il verso di apertura, lo spessore del vetro e mandare il disegno fatto con [METALGLAS](#) al momento dell'ordine
- Please specify always opening direction, glass thickness and send technical drawing from [METALGLAS](#) when ordering
- Bitte immer Öffnungsrichtung, Glasdicke und technische Zeichnung von [METALGLAS](#) bei der Bestellung angeben

**MIS**

- Tagliato a misura del cliente
- Custom length
- Nach Mass geschnitten

**> SET 10**

- Prezzo su richiesta
- Price on request
- Preis auf Anfrage
- Progettazione configurazioni speciali da € 200 a € 600 netto
- Special design from € 200 till € 600 net
- Spezielle planung ab € 200 bis € 600 Netto

- Specificare se per esterni
- Please specify always
- Bitte immer Öffnungsrichtung

4



POS.	PROD.	ART.
<b>PA-200</b>		
<b>OPTIONALS</b>		
PA-100, PA-113, L-112 e L-112-PA inclusi nel set   PA-100, PA-108, PA-109, PA-109-DX, PA-109-SX, WRU-M 80/50 MT5, WRU-S 60/40 R, WRU-S 60/40 R M50, WRU-S 100/60 Z, WRU-S 100/60 Z M100		
C.2		PA-100 FIX-3000 PA-100 FIX-6000
C.3		<b>TAGLIO-PM</b> • Costo per extra taglio mis • Extra cost track profiles cut • Aufpreis Laufschiene nach
C.4		PA-108-DX PA-108-SX
C.5		PA-109-DX PA-109-SX
C.6		L-112-PA • For panel D
C.7		L-112 • For panel A - B - C
C.8		PA-113
C.9		WRU-M 80/50 MT5
C.10		WRU-S 60/40 R WRU-S 60/40 R M50
C.11		WRU-S 100/60 Z WRU-S 100/60 Z M100
C.12		PA-200 ANTA A
C.13		PA-200 ANTA B
		PA-200 ANTA C

**OUTDOOR PARETI MOBILI**  
**LISTINO PREZZI PRICE LIST PREISLISTE**

 PARETI MOBILI  
 SLIDING WALLS  
 SCHIEBEWÄNDE

... **RITROVERAI VELOCEMENTE**  
**LO STESSO CODICE NEL**  
**LISTINO**

YOU'LL FIND QUICKLY  
 THE SAME CODE  
 IN THE PRICE LIST

... SIE FINDEN SCHNELL  
 DEN GLEICHEN CODE  
 IN DER PREISLISTE



01/2020

# LEGENDA SIMBOLI

## SYMBOL LEGEND

## SYMBOLLEGENDE



8-10

SPESSORE VETRO  
GLASS THICKNESS  
GLASDICKE



1000

MISURE ANTA  
PANEL MEASURES  
TÜRGRÖSSE



70 Kg

PORTATA  
LOAD CAPACITY  
TRAGKRAFT



SISTEMA SOFT-CLOSE  
SOFT-CLOSE SYSTEM  
SOFT-CLOSE SYSTEM



70 Kg

PORTATA DEL SISTEMA SOFT-CLOSE  
LOAD CAPACITY OF THE SOFT-CLOSE SYSTEM  
TRAGKRAFT DES SOFT-CLOSE SYSTEMS

**FIXED**

ANTA FISSA  
FIXED PANEL  
SEITENTEIL



ANTA SCORREVOLE  
SLIDING DOOR  
SCHIEBETÜR

**MY METALGLAS**

CONFIGURATORE ESCLUSIVO  
METALGLAS PER SEMPLIFICARE  
LA REALIZZAZIONE DI SISTEMI  
IN VETRO TEMPERATO

EXCLUSIVE CONFIGURATOR METALGLAS  
TO SIMPLIFY THE CREATION OF SYSTEMS  
IN TEMPERED GLASS

EXKLUSIVER KONFIGURATOR METALGLAS  
ZU VEREINFACHEN DIE ERSTELLUNG  
VON SYSTEMEN AUS GEHÄRTETEM GLAS



# LEGENDA ABBREVIAZIONI

## ACRONYM LEGEND

## ERKLÄRUNG DER ABKÜRZUNGEN

<b>LP</b>	PASSAGGIO LUCE CLEAR OPENING WIDTH LICHTE DURCHGANGSBREITE	<b>HB</b>	ALTEZZA FISSAGGIO BINARIO RAIL INSTALLATION HEIGHT LAUFSCHIENENMONTAGE HÖHE
<b>H / HP</b>	ALTEZZA PASSAGGIO LUCE CLEAR OPENING HEIGHT LICHTE DURCHGANGSHÖHE	<b>LV</b>	LARGHEZZA VETRO GLASS WIDTH GLAS BREITE
<b>LM / LA</b>	LARGHEZZA ANTA MOBILE SLIDING DOOR WIDTH SCHIEBEFLÜGEL BREITE	<b>HV</b>	ALTEZZA VETRO GLASS HEIGHT GLAS HÖHE
<b>HM / HA</b>	ALTEZZA ANTA MOBILE SLIDING GLASS HEIGHT SCHIEBEFLÜGEL HÖHE	<b>LV</b>	LARGHEZZA VETRO GLASS WIDTH GLAS BREITE
<b>HF</b>	ALTEZZA ANTA FISSA SIDE FIXED GLASS HEIGHT SEITENTEIL HÖHE	<b>HS</b>	ALTEZZA STIPITE FRAME HEIGHT ZARGE HÖHE
<b>LF</b>	LARGHEZZA ANTA FISSA FIXED GLASS WIDTH SEITENTEIL BREITE	<b>LS</b>	LARGHEZZA STIPITE FRAME WIDTH ZARGE BREITE
<b>LB</b>	LUNGHEZZA BINARIO RAIL LENGTH LAUFSCHIENENLÄNGE		

# FINITURE

## FINISHES

## OBERFLÄCHEN

	<b>CP</b> CROMO PERLA CHROME PERLA SIMILAR ALU CHROM PERLA ÄHNLICH ALU		<b>AN</b> ALLUMINIO ANODIZZATO ALUMINIUM ANODIZED ALUMINIUM SILBERFARBIG
	<b>CS</b> CROMO SATINATO SATIN CHROME CHROM MATT		<b>IX</b> ACCIAIO INOX SATINATO SATIN STAINLESS STEEL EDELSTAHL MATT
	<b>NS</b> NICKEL SATINATO SATIN NICKEL ÄHNLICH EDELSTAHL MATT		<b>IXE</b> EFFETTO INOX SATINATO INOX EFFECT INOX EFFEKT
	<b>CR</b> CROMO LUCIDO POLISHED CHROME CHROM GLÄNZEND		<b>IL</b> ACCIAIO INOX LUCIDO POLISHED STAINLESS STEEL EDELSTAHL POLIERT
	<b>OL</b> OTTONE LUCIDO POLISHED BRASS MESSING POLIERT		<b>NO</b> NERO OPACO MATT BLACK SCHWARZ MATT
	<b>BI</b> BIANCO WHITE WEISS		

## MY METALGLAS

### IL CONFIGURATORE ESCLUSIVO PER I CLIENTI METALGLAS *THE EXCLUSIVE CONFIGURATOR FOR METALGLAS CUSTOMERS* *DER EXKLUSIVE KONFIGURATOR FÜR KUNDEN VON METALGLAS*

#### COS'È / WHAT IS IT? / WAS IST DAS?

- MYMETALGLAS è il configuratore gratuito pensato per semplificare la realizzazione di sistemi in vetro temperato realizzando prodotti Metalglas.
- *MYMETALGLAS is the free configurator designed with Metalglas products, able to simplify the creation of systems in tempered glass.*
- *MYMETALGLAS ist ein kostenloser Konfigurator, der entwickelt wurde, um die Umsetzung von Systemen aus gehärtetem Glas mit Produkten von Metalglas zu vereinfachen.*

#### PENSATO PER TE / DESIGNED FOR YOU / FÜR SIE ENTWICKELT

- Bastano pochi semplici passaggi per registrarsi e accedere al programma. È sufficiente scegliere i prodotti e gli accessori per ottenere le misure esecutive di taglio vetro necessarie al tuo progetto.
- *Only a few simple steps to register and have access to the programme. Just choose the products and accessories to get the precise measures needed for the glass to be cut to your project's specifications.*
- *Wenige einfache schritte reichen aus, um sich zu registrieren und das Programm aufzurufen. Danach müssen sie einfach die Produkte und Zubehörteile auswählen, um die tatsächlichen Schnittmaße für das Glas zu erhalten, das sie für ihr Projekt benötigen.*

#### COME FUNZIONA / HOW IT WORKS / WIE FUNKTIONIERT ES?

- Calcolare le misure esatte per tagliare o forare un vetro non è mai semplice. MYMETALGLAS è lo strumento operativo pensato per aiutarti a lavorare meglio e più velocemente.
- *Calculating the exact measures for cutting or drilling a piece of glass is never simple. MyMetalglas is the operational tool designed to help you work faster and better.*
- *Das Berechnen der genauen Maße, um ein Glas zu schneiden oder zu bohren, ist nicht einfach. MYMETALGLAS ist das perfekte Instrument, das Ihnen dabei hilft, besser und schneller zu arbeiten.*

**FACILITA IL TUO LAVORO CON:**  
**SIMPLIFY YOUR WORK WITH:**  
**ERLEICHTERN SIE IHRE ARBEIT MIT:**

**MYMETALGLAS.IT**

# MY METALGLAS

## MYMETALGLAS È UN PRODOTTO ESCLUSIVO DI METALGLAS

*MYMETALGLAS IS AN EXCLUSIVE METALGLAS PRODUCT*

*MYMETALGLAS IST EIN EXKLUSIVPRODUKT VON METALGLAS*

- MYMETALGLAS è l'innovativo configuratore gratuito pensato per semplificare la realizzazione di sistemi in vetro temperato, ideati con i prodotti Metalglas.
- Calcolare le misure esatte per tagliare o forare un vetro non è un'operazione semplice. Per questo abbiamo realizzato MYMETALGLAS, **lo strumento che minimizza il rischio di errore e velocizza il tuo lavoro.**
- MYMETALGLAS is the innovative free configurator designed with Metalglas products, able to simplify the creation of systems in tempered glass.
- Calculating the exact measures for cutting or drilling a piece of glass is not a simple operation. For this reason, we created MYMETALGLAS, **the tool that minimises the risk of error and speeds up your work.**
- MYMETALGLAS ist ein innovativer und kostenloser Konfigurator, der zur Vereinfachung der Umsetzung von Systemen aus gehärtetem Glas mit Produkten von Metalglas entwickelt wurde.
- Die exakten Abmessungen zum Schneiden oder Bohren eines Glases zu ermitteln, ist nicht einfach. Daher haben wir MYMETALGLAS entwickelt, **ein Instrument, mit dem das Fehlerrisiko minimiert und Ihre Arbeit beschleunigt wird.**



# MY METALGLAS

## COME UTILIZZARE MYMETALGLAS HOW TO USE MYMETALGLAS VERWENDUNG VON MYMETALGLAS

- MYMETALGLAS è il configuratore pensato per semplificare la realizzazione di sistemi in vetro temperato utilizzando prodotti Metalglas.  
Rendi il tuo lavoro veloce e preciso, con MYMETALGLAS ora potrai calcolare facilmente le misure esatte per tagliare o forare un vetro.
- MYMETALGLAS is the configurator designed with Metalglas products, able to simplify the creation of systems in tempered glass. It makes your work fast and precise; with MYMETALGLAS you can now easily calculate the exact measures for cutting or drilling glass.
- MYMETALGLAS ist ein Konfigurator, der die Herstellung von Systemen aus gehärtetem Glas mit Produkten von Metalglas vereinfacht. Gestalten Sie Ihre Arbeit schneller und genauer, denn mit MyMetalglas können Sie nun einfach die richtigen Maße zum schneiden oder bohren eines Glases berechnen.

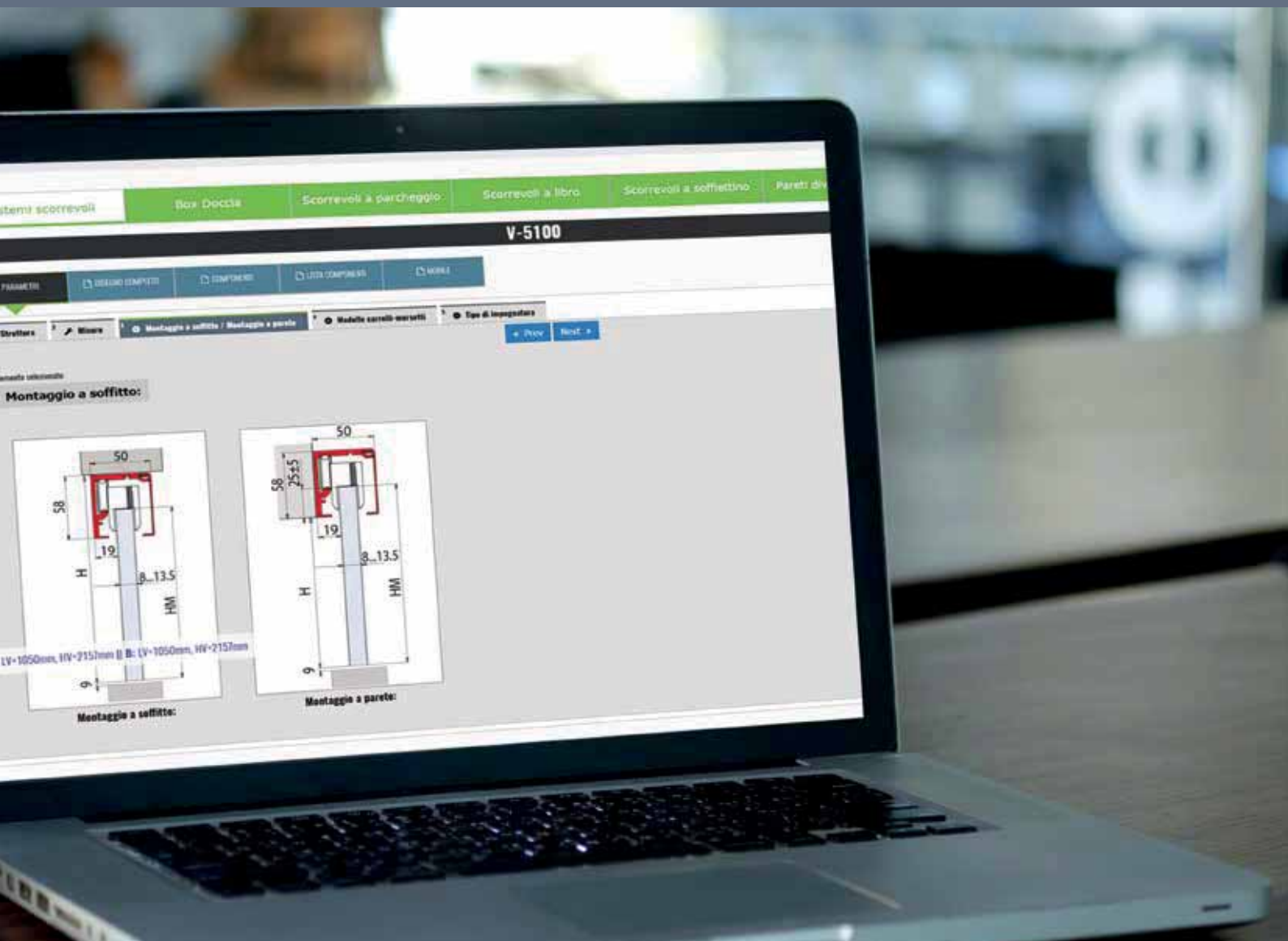

# MY METALGLAS

## REALIZZA IL TUO PROGETTO IN POCHI SEMPLICI PASSAGGI CREATE YOUR PROJECT IN A FEW SIMPLE STEPS SETZEN SIE IHR PROJEKT MIT WENIGEN, EINFACHEN SCHRITTEN UM

### 1 CREA IL TUO PROGETTO / *CREATE YOUR PROJECT* / *ERSTELLEN SIE IHR PROJEKT*

- Scegli i prodotti che ti servono e realizza il progetto che vuoi, inserendo tutti i dettagli di cui hai bisogno, come ad esempio se vuoi la posa a soffitto o a parete.
- Choose the products you need and create the project that you want, inserting all the required details, such as, for example, if it is a ceiling or wall installation.
- Wählen Sie die Produkte aus, die Sie benötigen, und setzen Sie das Projekt um, indem Sie die Details, die notwendig sind, eingeben. Dazu gehört beispielsweise die Wahl zwischen Decken- und Wandverlegung.



### 2 CONFIGURA IL TUO PROGETTO / *CONFIGURE YOUR PROJECT* / *KONFIGURIEREN SIE IHR PROJEKT*

- Scegli gli accessori da applicare, come ad esempio la maniglia o il tipo di apertura che si adatta al tuo progetto.
- Choose the accessories to apply, such as, for example, handles or the type of opening that is best suited to your project.
- Wählen Sie die anzuwendenden Zubehörteile wie etwa den Griff oder die geeignete Öffnungsart aus.



### 3 OTTIENI LE MISURE ESATTE / *GET THE EXACT MEASUREMENTS* / *ERHALTEN SIE DIE RICHTIGEN MASSE*

- Stampa le misure esecutive di taglio vetro e la lista completa dei componenti che ti serviranno. Potrai salvare il progetto e consultarlo ogni volta che ne avrai esigenza.
- Print the measurements of glass to be cut and the complete list of components that you need. You can save the project and consult it any time you need to.
- Drucken Sie die auszuführenden Schnittmaße sowie die vollständige Liste aller benötigten Teile aus. Sie können das Projekt speichern und bei Bedarf stets wieder aufrufen.





PARETI MOBILI  
*SLIDING WALLS*  
*SCHIEBEWÄNDE*

C

# PARETI MOBILI

SLIDING WALLS  
SCHIEBEWÄNDE



## SCORREVOLI A PARCHEGGIO con baia di parcheggio e senza guida a terra

SLIDING STACKING SYSTEMS  
with parking bay and without bottom guide channel

GANZGLAS-SCHIEBEWANDSYSTEME  
mit Parkraum und ohne Bodenführung

► 18

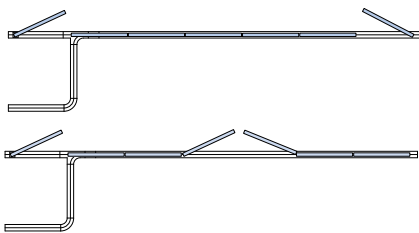

PA-300  
PA-230  
PA-630

PA-200 / PA-700 / PA-400 / PA-500  
PA-600 / PA-200-ISO

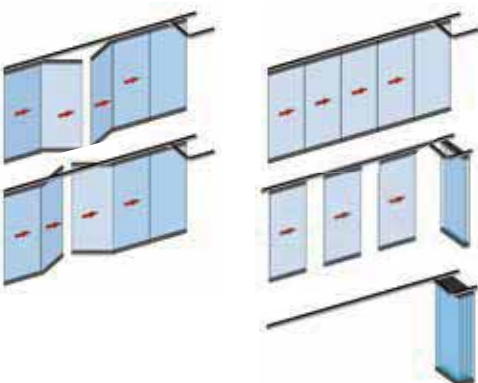

## SCORREVOLI A LIBRO con canalina a terra

SLIDING FOLDING SYSTEMS  
with bottom guide channel

FALT-SCHIEBEWANDSYSTEME  
mit Bodenführung

► 70

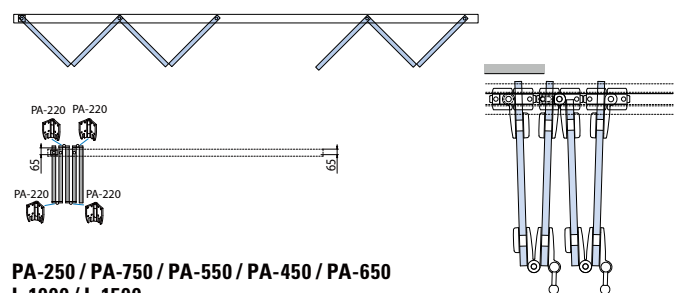

PA-250 / PA-750 / PA-550 / PA-450 / PA-650  
L-1000 / L-1500

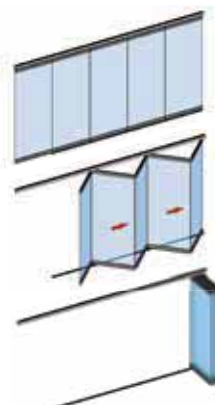





**SCORREVOLI A SOFFIETTO**  
senza canalina a terra

*CENTER FOLDING SYSTEMS*  
without floor channel

*FALT-SCHIEBEWANDSYSTEME*  
mit mittiger Faltung ohne Bodenschiene

► 100

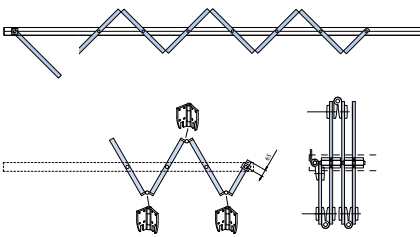

**PA-260 / PA-760**  
**PA-560 / PA-460 / L-2500**

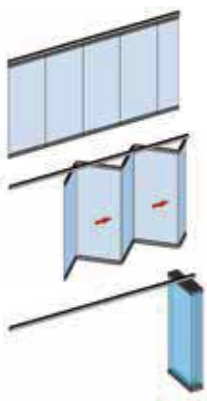

**SISTEMI BALCONGLAS**  
con o senza canalina a terra,  
senza baia di parcheggio

*BALCONGLAS SYSTEMS*  
with or without bottom channel  
and without parking bay

*SYSTEME BALCONGLAS*  
mit oder ohne Bodenschiene  
und ohne Parkraum

► 118



**FALCINO-50 / FALCINO-PARK-50**  
**FALCE-70 / FALCE-PARK-70**  
**FALCE-70B / FALCE-PARK-70B**  
**FALCE-ISO / FALCE-PARK-ISO**

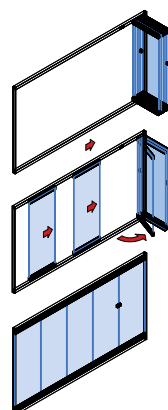

**LOGGIAGLAS**  
sistema scorrevole telescopico  
per balconi, logge e verande

*LOGGIAGLAS*  
Telescopic sliding system for balcony,  
Loggia and terrace

*LOGGIAGLAS*  
Teleskop Schiebetürsystem für Balkon und  
Loggiaverglasungen

► 148

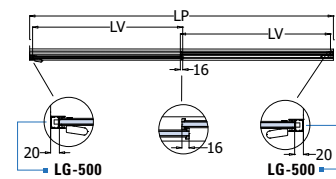

**LOGGIAGLAS LG-500**  
**LOGGIAGLAS LG-400**

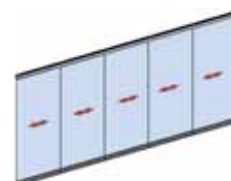

# GUIDA TECNICA PER LA SCELTA DEL VOSTRO SISTEMA

TECHNICAL GUIDE FOR THE CHOICE OF YOUR SYSTEM  
AUSWAHL VON SYSTEME NACH VORHANDENEN KRITERIEN

INDEX

**SCORREVOLI A PARCHEGGIO**  
con baia di parcheggio e senza guida a terra  
**SLIDING STACKING SYSTEM**  
with parking bay and without bottom guide channel  
**GANZGLAS-SCHIEBEWANDSYSTEME**  
mit Parkraum und ohne Bodenführung

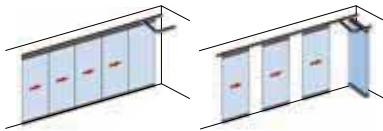

**PA-200**  
**PARK LINE 1**

▶ 20

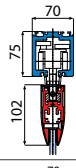

**PA-300**  
**PARK LINE 2**

▶ 26

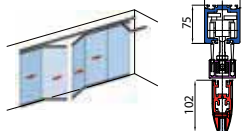

**PA-230**

▶ 34

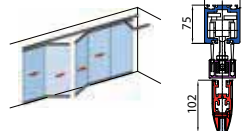

**PA-700 PARK**  
do-it-yourself

NEW

▶ 36

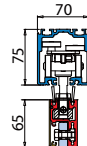

**PA-400 PARK**  
do-it-yourself

▶ 42

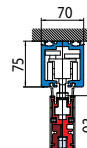

**PA-500 PARK**  
do-it-yourself

▶ 44

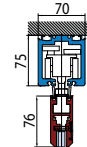

**PA-600 FORTI SPESSORI**

▶ 50

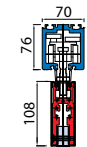

**PA-630 FORTI SPESSORI**

▶ 56



**PA-200 ISO**  
do-it-yourself

▶ 64

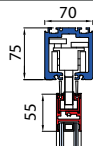

**SCORREVOLI A LIBRO**  
Con guida a terra  
**SLIDING FOLDING SYSTEM**  
with bottom guide channel  
**FALT-SCHIEBEWANDSYSTEME**  
mit Bodenführung

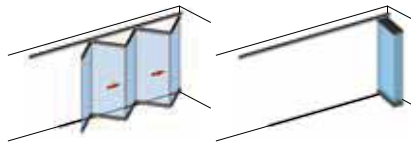

**PA-250**  
**LIBRO FOLDING**

▶ 72

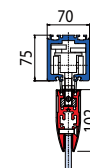

**PA-750**  
**LIBRO FOLDING**  
do-it-yourself

NEW

▶ 78

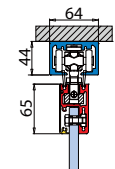

**PA-550**  
**LIBRO FOLDING**  
do-it-yourself

▶ 86

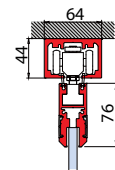

**PA-450**  
**LIBRO FOLDING**  
do-it-yourself

▶ 84

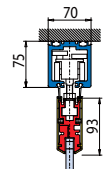

**PA-650**

▶ 92

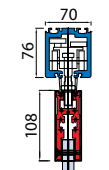

**L-1500**  
**LIBRO FOLDING**

▶ 94

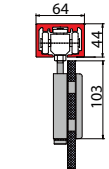

**L-1000**  
**LIBRO FOLDING**

▶ 96

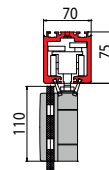

**SCORREVOLI A SOFFIETTO**  
Senza guida a terra  
**CENTER FOLDING SLIDING SYSTEM**  
without floor rail  
**FALT-SCHIEBEWANDSYSTEME**  
mit mittiger Faltung ohne Bodenführung

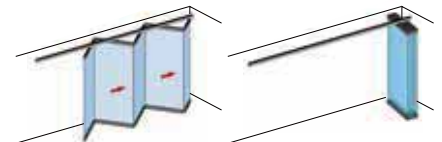

**PA-260**  
**CENTER FOLDING**

▶ 102

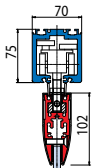

**PA-760**  
**CENTER FOLDING**  
do-it-yourself

NEW

▶ 106

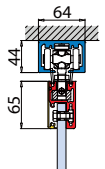

**PA-560**  
**CENTER FOLDING**  
do-it-yourself

▶ 112

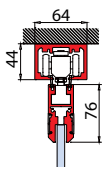

**PA-460**  
**CENTER FOLDING**  
do-it-yourself

▶ 110

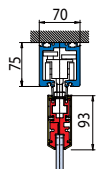

**L-2500 SOFFIETTO**  
**CENTER FOLDING**

▶ 116

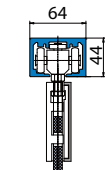

**SISTEMI BALCONGLAS**  
 Pareti mobili, senza baia di parcheggio  
**BALCONGLAS SLIDE AND TURN SYSTEMS**  
 without parking bay  
**SCHIEBE-DREH-SYSTEME BALCONGLAS**  
 ohne Parkraum

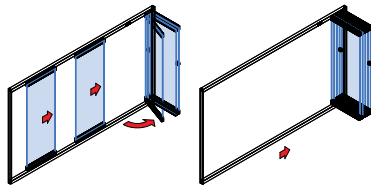

**BALCONGLAS FALCINO**



**BALCONGLAS FALCINO-50**

SISTEMA CON CANALINA  
 SYSTEMS WITH BOTTOM GUIDE  
 SYSTEM MIT BODENFÜHRUNG

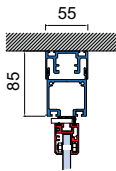

► 120

**BALCONGLAS FALCINO PARK-50**

SISTEMA SENZA CANALINA  
 SYSTEMS WITHOUT BOTTOM GUIDE  
 SYSTEM OHNE BODENFÜHRUNG

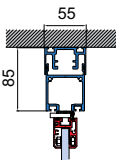

► 124

**BALCONGLAS FALCE**



**BALCONGLAS FALCE-70**

SISTEMA CON CANALINA  
 SYSTEMS WITH BOTTOM GUIDE  
 SYSTEM MIT BODENFÜHRUNG

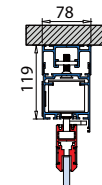

► 128

**BALCONGLAS FALCE PARK-70**

SISTEMA SENZA CANALINA  
 SYSTEMS WITHOUT BOTTOM GUIDE  
 SYSTEM OHNE BODENFÜHRUNG

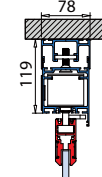

► 132

**BALCONGLAS FALCE-70B**

SISTEMA CON CANALINA  
 SYSTEMS WITH BOTTOM GUIDE  
 SYSTEM MIT BODENFÜHRUNG

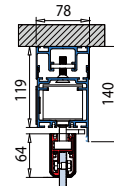

► 136

**BALCONGLAS FALCE PARK-70B**

SISTEMA SENZA CANALINA  
 SYSTEMS WITHOUT BOTTOM GUIDE  
 SYSTEM OHNE BODENFÜHRUNG

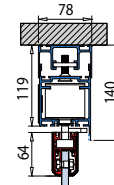

► 137

**BALCONGLAS FALCE ISO**

SISTEMA CON CANALINA  
 SYSTEMS WITH BOTTOM GUIDE  
 SYSTEM MIT BODENFÜHRUNG

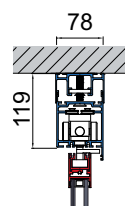

► 138

**BALCONGLAS FALCE PARK-ISO**

SISTEMA SENZA CANALINA  
 SYSTEMS WITHOUT BOTTOM GUIDE  
 SYSTEM OHNE BODENFÜHRUNG

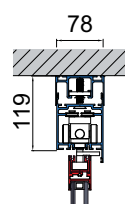

► 142

**LOGGIAGLAS**  
 Sistema scorrevole telescopico per balconi,  
 logge e verande

**LOGGIAGLAS Telescopic sliding system for balconies, loggias and terraces**

**LOGGIAGLAS Teleskop Schiebetürsystem für Balkon und Loggiaverglasungen**

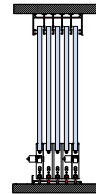

**LOGGIAGLAS LG-500**

► 148

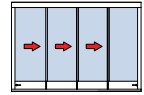

**LOGGIAGLAS LG-400**

► 164

NEW

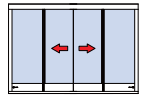

# SCORREVOLI A PARCHEGGIO

## SLIDING STACKING SYSTEMS

### GANZGLAS-SCHIEBEWANDSYSTEME

Con baia di parcheggio e senza canalina a terra / With parking bay and without bottom channel / Mit Parkraum und ohne Bodenschiene

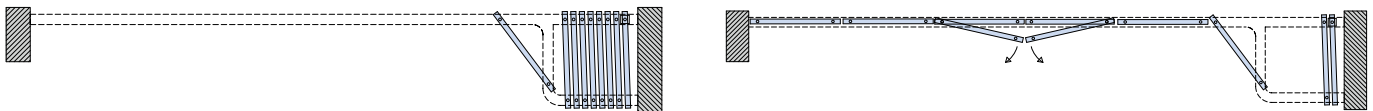

#### PA-200 PARK LINE 1 ▶ 20

#### PA-600 FORTI SPESSORI ▶ 50

- Sistema scorrevole a parcheggio fornito con profili fermavetro a misure richiesta dal cliente, senza necessità di fori nel vetro.
- Sliding stacking system with glass fixing profiles made to measure upon client's request, no glass preparation.
- Schiebesystem mit Parkraum, kundenspezifische Glasleistenprofile ohne Glasbohrungen.

<b>PA-200</b>
150 Kg
10-12-12,7
3500 550 min 1250 max

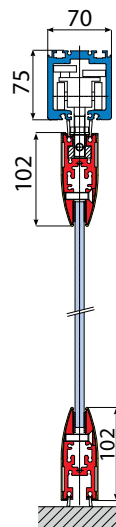

<b>PA-600</b>
150 Kg
16,76 / 17,52
3500 550 min 1000 max

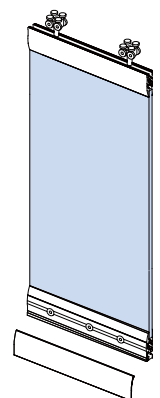
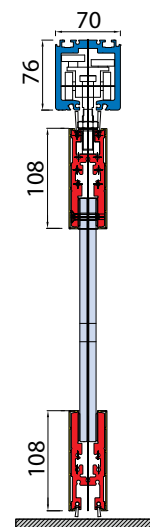

#### PA-200-ISO do-it-yourself ▶ 64

- Sistema scorrevole a parcheggio fornito con profili per anta intelaiata, misure standard per anta max 1000 x 3000 mm da tagliare cliente
- Sliding stacking system with profiles for framed glass door standard measure up to 1000 x 3000 mm. cut by installer.
- Schiebesystem mit Parkraum, mit Flügelrahmen für standard Tür max 1000 x 3000 mm. Schnitt bauseitig.

<b>PA-200-ISO</b>
120 Kg
3,3-14-3,3
3000 550 min 1000 max

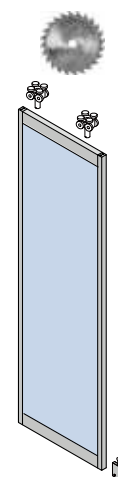
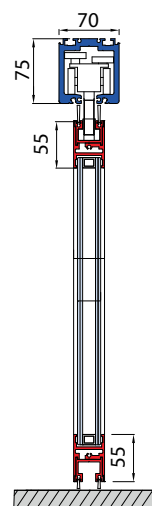

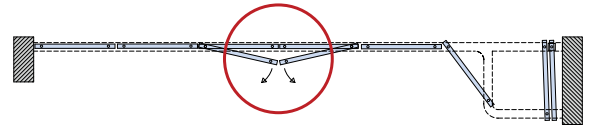

**PA-300 PARK LINE 2 ▶ 26**
**PA-230 ▶ 34**
**PA-630 FORTI SPESSORI ▶ 56**

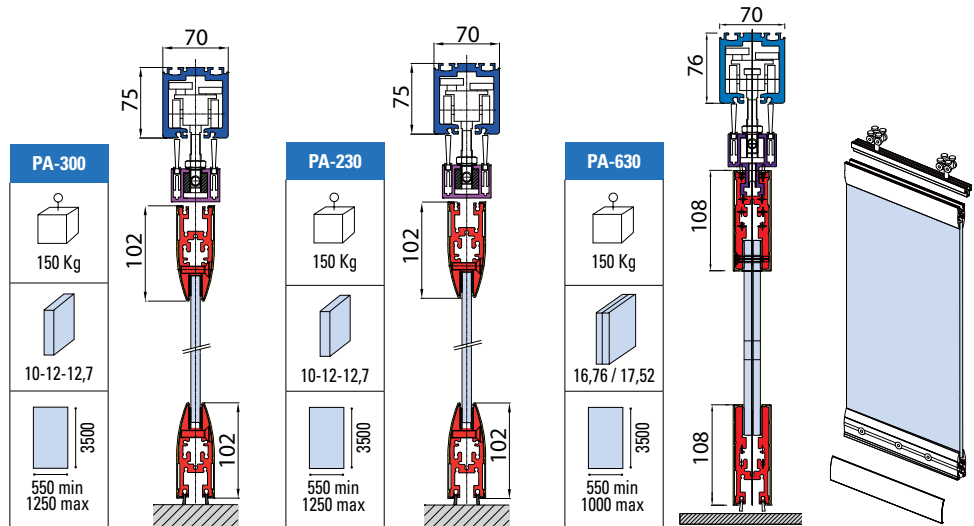
- Sistemi scorrevoli a parcheggio con profili fermavetro a misure richiesta dal cliente, senza fori nel vetro e con possibilità di porta centrale a battente e parcheggiabile.
- Sliding stacking systems with glass fixing profiles made to measure upon client's request, no glass preparation and with the possibility of hinged and stackable panel.
- Schiebesysteme mit Parkraum, mit kundenspezifischen Glasleistenprofile, mit zentraler Drehtür und Parkmöglichkeit.

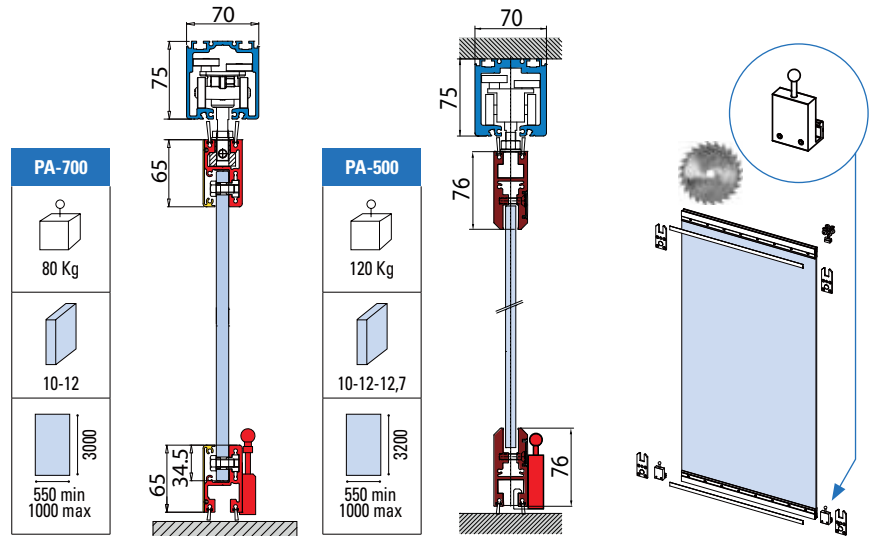

 SCORREVOLI A PARCHEGGIO  
SLIDING STACKING SYSTEMS

**PA-700 PARK do-it-yourself ▶ 36**
**PA-500 PARK do-it-yourself ▶ 44**

- Sistema scorrevole a parcheggio con profili fermavetro continui a misura standard (mm 1000) da tagliare secondo necessità a cura del cliente, completi di catenaccioli ferma anta a posizionamento esterno regolabile. Vantaggi di una consegna più veloce e di un unico prodotto a magazzino per tutte le misure fino a 1000 mm.
- Modular sliding stacking system with continuous glass fixing profiles of a standard size (mm 1000) to be cut on the basis of client's requirements comes equipped with an adjustable door holding latch positioned externally. The advantage of this product is quick delivery and a unique product available in the warehouse for all sizes up to 1000 mm.
- Schiebesystem mit Parkraum, durchgehenden Laufschiene-Profilen in Standardgröße (1000 mm), ablängbar, komplett mit äußeren einstellbaren Riegeln zur Flügelbefestigung. Vorteile einer raschen Lieferung und eines einzigen lagermäßigen Produktes mit Abmessungen bis 1000 mm.

**PA-400 PARK do-it-yourself ▶ 42**

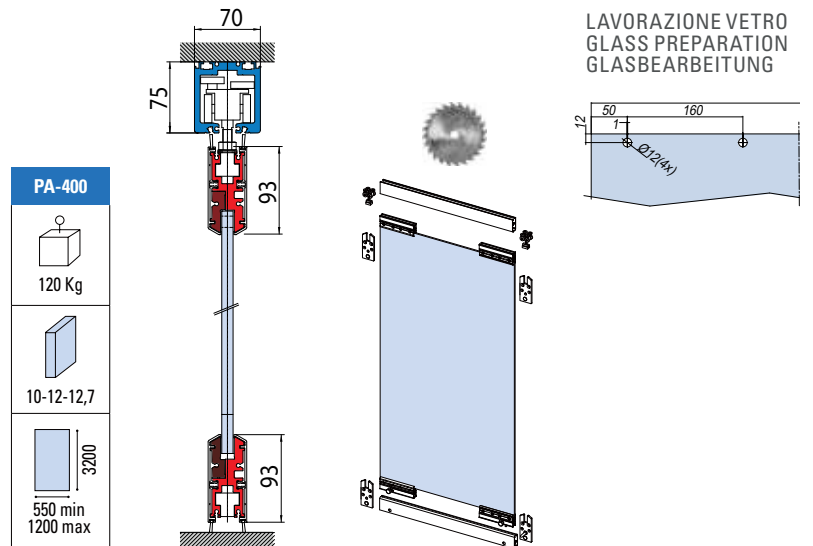
- Sistema scorrevole modulare a parcheggio con morsetti fermavetro (mm 250) e veletta continua (mm 1200) da tagliare secondo necessità a cura del cliente. Vantaggi di una consegna più veloce e di un unico prodotto a magazzino per tutte le misure fino a 1200 mm.
- Modular sliding stacking system with glass fixing clamps (mm 250) and continuous covers (mm 1200) to be cut on the basis of client's requirements. The advantage of this product is quick delivery and a unique product available in the warehouse for all sizes up to 1200 mm.
- Modulares Schiebesystem mit Parkraum, Glashalteklammern (250 mm) mit kontinuierlicher Verkleidung (mm 1200) kundenspezifisch ablängbar. Vorteile einer raschen Lieferung und eines einzigen lagermäßigen Produktes mit Abmessungen bis 1200 mm.



# PA-200 PARK LINE 1

SCORREVOLI A PARCHEGGIO / SLIDING STACKING SYSTEMS / GANZGLAS-SCHIEBEWANDSYSTEME

**MY METALGLAS**

€ C.01

SCORREVOLI A PARCHEGGIO  
SLIDING STACKING SYSTEMS



- Sistema scorrevole a parcheggio fornito con profili fermavetro su misura richiesta dal cliente, senza necessità di fori nel vetro.
- Sliding stacking system with glass fixing profiles made to measure upon client's request, no need to make holes in the glass.
- Schiebesystem mit Parkraum, kundenspezifische Glasleistenprofile ohne Glasbohrungen.

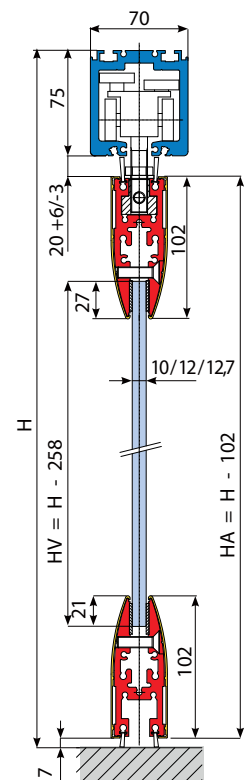

HV = H - 258

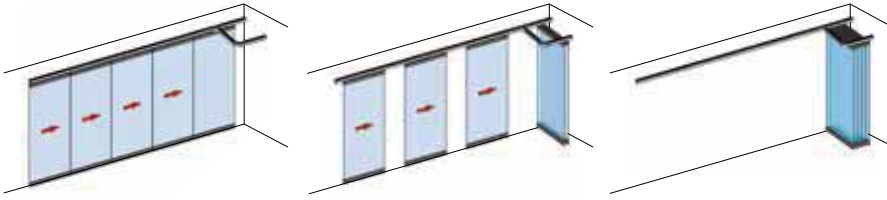

10-12-12,7	150 Kg	110 Kg	3500
			550 min 1250 max

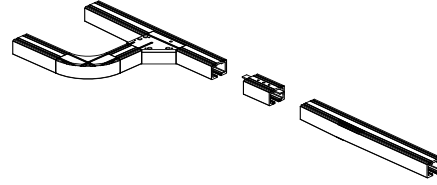
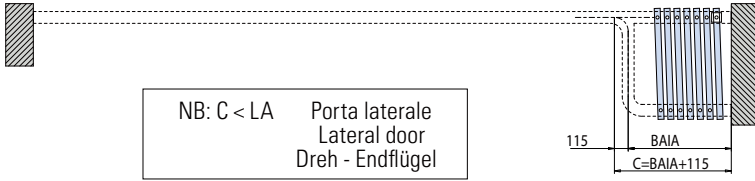

PA-108

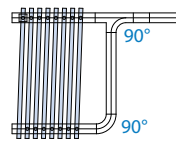

PA-109

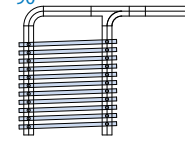

PA-113

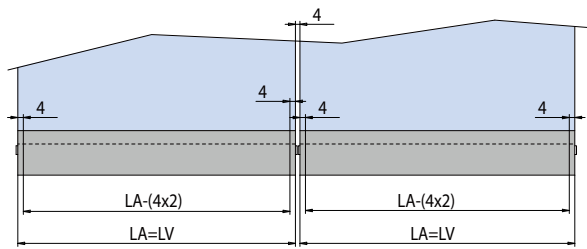
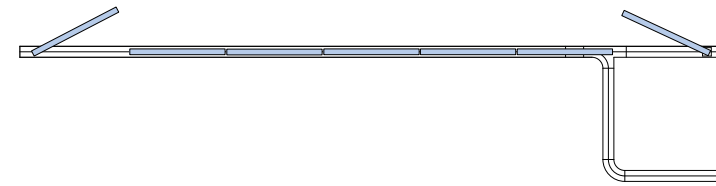
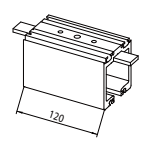

- Baie da ordinare a parte oltre alle ante, altre baie disponibili da pag. 66
- To be ordered separately from the panels, other parking bays available from page 66
- Neben den Flügel extra zu bestellen, andere Parkräume auf Seite 66

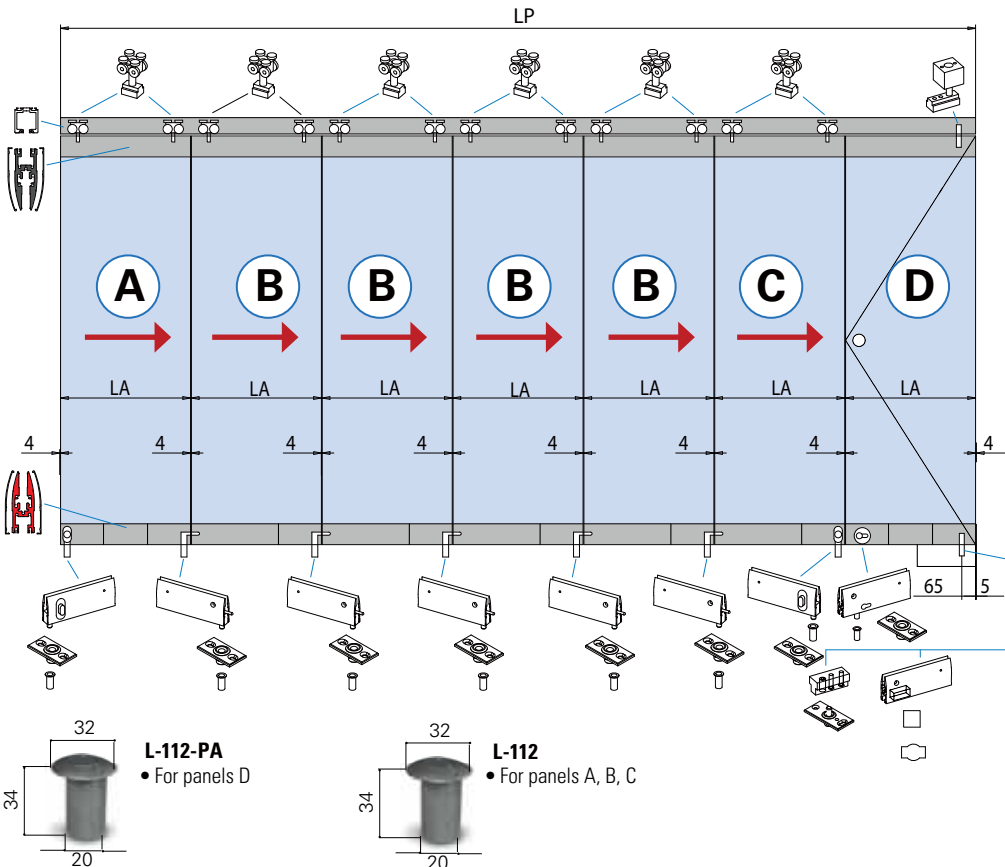

- Calcolo vetro
- Calculation glass
- Glasberechnung

$At = 4 \times (N + 1)$   
 $X = LP - At$   
 $LA = LV = X / N$

- A**
  - Prima anta
  - First panel
  - Erster Schiebeflügel
- B**
  - Anta intermedia
  - Intermediate panel
  - Zwischen-Schiebeflügel
- C**
  - Ultima anta
  - Last panel
  - End-Schiebeflügel
- D**
  - Porta laterale
  - Lateral pivot door
  - Dreh-Schiebeflügel

xme295 / xla171BIS-1

AN	At	N	LP	LA = LV	H	HV	HA
Alluminio anodizzato Aluminium anodized Aluminium Silberfarbig	Arie totali Total clearances Summe alle Abstände Glas/Wand	Numero ante Numbers panels Anzahl der Elemente	Passaggio luce Clear opening width Lichte Durchgangsbreite	Larghezza ante = Larghezza vetro Panel width = Glass width Flügelbreite = Glasbreite	Altezza passaggio luce Clear opening height Lichte durchgangshöhe	Altezza vetro Glass height Glashöhe	Altezza anta Door height Tür Höhe

# PA-200 PARK LINE 1

**COME USARE MY METALGLAS / HOW TO USE MY METALGLAS / WIE MAN BENUTZT MY METALGLAS**

**1**

INSERIRE LE MISURE DEL TUO VANO E LE ANTE DESIDERATE  
ENTER THE MEASUREMENTS OF YOUR OPENING AND THE DOORS YOU REQUIRE  
GEBEN SIE DIE MASSE IHRER ÖFFNUNG EIN UND DIE ERFORDERLICHEN TÜREN

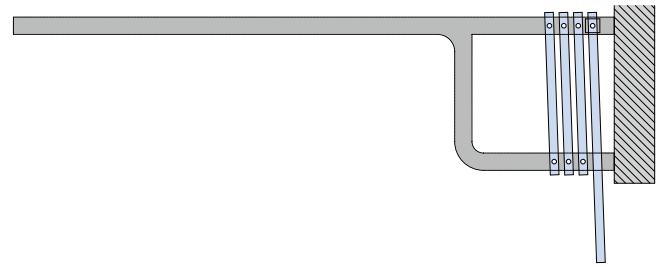
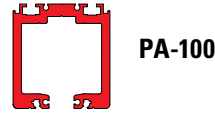
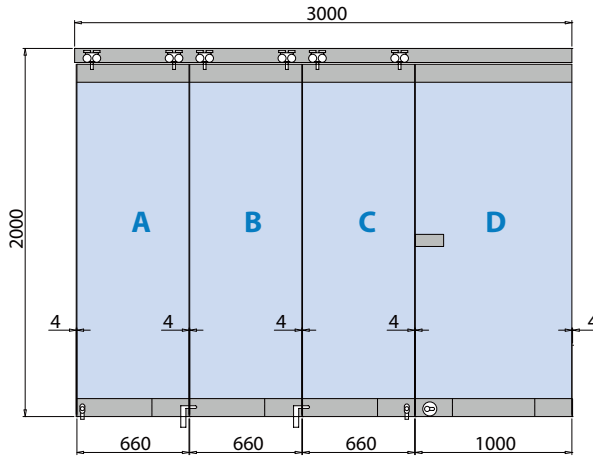

**2**

SI OTTENGONO LE MISURE DEI VETRI AUTOMATICAMENTE  
THE MEASUREMENTS OF THE GLASS WILL BE GENERATED AUTOMATICALLY  
DIE ABMESSUNGEN DES GLASES WERDEN AUTOMATISCH BERECHNET

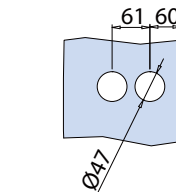
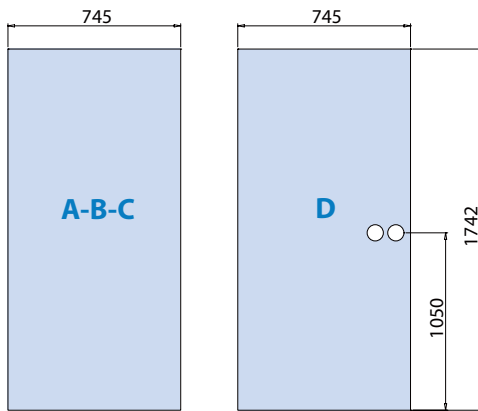

- Foratura vetro porta battente per serrature optional
- Glass preparation pivot door for optional locks
- Glasbearbeitung Dreh-Flügel für optionale Schlösser

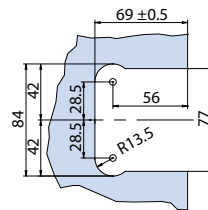

- Foratura vetro porta battente per serrature optional V-504, V-505, V-518, V-519, V-520
- Glass preparation pivot door for optional locks V-504, V-505, V-518, V-519, V-520
- Glasbearbeitung Dreh-Flügel für optionale Schlösser V-504, V-505, V-518, V-519, V-520

**3**

SI OTTENGONO LE DISTINTE DI TAGLIO DEI PROFILI, DA ABBINARE AGLI ACCESSORI  
THE CUTTING SPECIFICATIONS OF THE PROFILES ARE OBTAINED, FOR MATCHING WITH THE ACCESSORIES  
SIE ERHALTEN EINE SPEZIFIKATION DER PROFILLÄNGEN ZUM ABGLEICHEN MIT DEM ZUBEHÖR

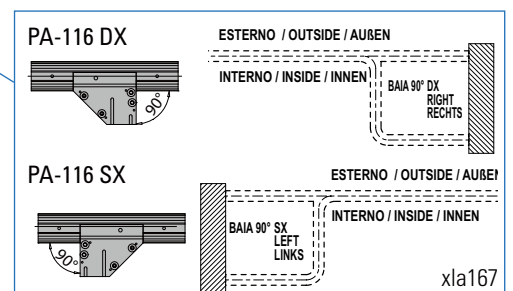
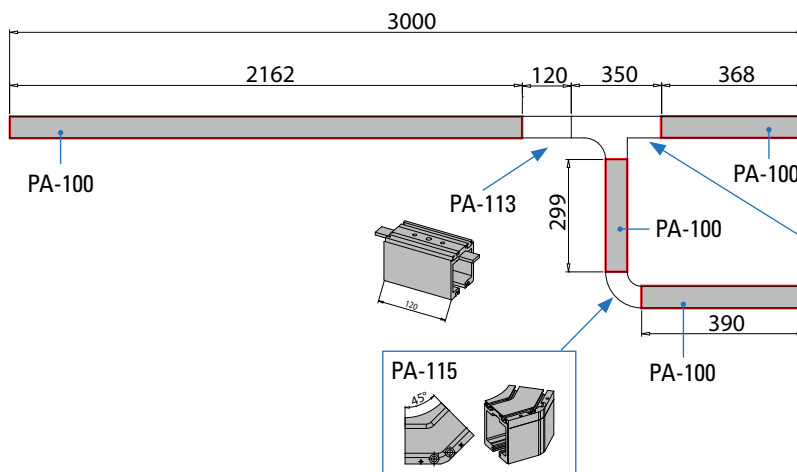

xl167

xme539



# PA-200 PARK LINE 1

## COME ASSEMBLARE LE ANTE / HOW TO ASSEMBLE THE DOORS / WIE DIE TÜREN ZUSAMMENGESETZT WERDEN

<b>TAGLIO PROFILI</b> PROFIL PREPARATION / PROFILBEARBEITUNG		<b>KIT ACCESSORI</b> ACCESSORY SETS / ZUBEHÖR SETS		<b>ANTA COMPLETA</b> COMPLETE DOOR / KOMPLETTE TÜR
<p><b>ANTA A / DOOR A / TÜRA</b></p> <p>PA-209 (x 2) PA-210 (x 4)</p> <p><b>SUPERIORE / TOP / OBEN</b></p> <p><b>INFERIORE / BOTTOM / UNTEN</b></p> <ul style="list-style-type: none"> <li>Lavorazione veletta con PA-225 + PA-203-POM</li> <li>Cover profile preparation with PA-225 + PA-203-POM</li> <li>Vorbereitung der Abdeckung mit PA-225 + PA-203-POM</li> </ul>	<p><b>PA-200 ANTA A-10</b> (for glass 10 mm)  <b>PA-200 ANTA A-12</b> (for glass 12 - 12,7 mm)                  PRIMA ANTA A / ERSTER SCHIEBEFLÜGEL A</p>			

 SCORREVOLI A PARCHEGGIO  
 SLIDING STACKING SYSTEMS

<p><b>ANTA B / DOOR B / TÜRB</b></p> <p>PA-209 (x 2) PA-210 (x 4)</p> <p><b>SUPERIORE / TOP / OBEN</b></p> <p><b>INFERIORE / BOTTOM / UNTEN</b></p>	<p><b>PA-200 ANTA B-10</b> (for glass 10 mm)  <b>PA-200 ANTA B-12</b> (for glass 12 - 12,7 mm)                  ANTA INTERMEDIA B / ZWISCHEN-SCHIEBEFLÜGEL B</p>	
---	--	--

<p><b>ANTA C / DOOR C / TÜRC</b></p> <p>PA-209 (x 2) PA-210 (x 4)</p> <p><b>SUPERIORE / TOP / OBEN</b></p> <p><b>INFERIORE / BOTTOM / UNTEN</b></p> <ul style="list-style-type: none"> <li>Lavorazione veletta con PA-225 + PA-203-POM</li> <li>Cover profile preparation with PA-225 + PA-203-POM</li> <li>Vorbereitung der Abdeckung mit PA-225 + PA-203-POM</li> </ul>	<p><b>PA-200 ANTA C-10</b> (for glass 10 mm)  <b>PA-200 ANTA C-12</b> (for glass 12 - 12,7 mm)                  ULTIMA ANTA C / END-SCHIEBEFLÜGEL C</p>	
---	---	--

# PA-200 PARK LINE 1

## COME ASSEMBLARE LE ANTE / HOW TO ASSEMBLE THE DOORS / WIE DIE TÜREN ZUSAMMENSETZT WERDEN

TAGLIO PROFILI  
PROFIL PREPARATION / PROFILBEARBEITUNG



KIT ACCESSORI  
ACCESSORY SETS / ZUBEHÖR SETS



ANTA COMPLETA  
COMPLETE DOOR / KOMPLETTE TÜR

SCORREVOLI A PARCHEGGIO  
SLIDING STACKING SYSTEMS

ANTA D / DOOR D / TÜRD

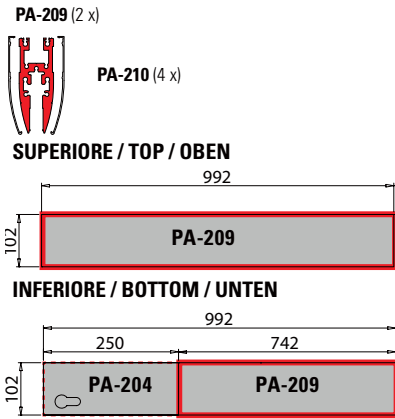

- Lavorazione veletta con **PA-204**
- Cover profile preparation with **PA-204**
- Vorbereitung der Abdeckung mit **PA-204**

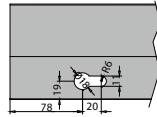

**PA-200-10** (for glass 10 mm)  
**PA-200-12** (for glass 12 - 12,7 mm)  
PORTA LATERALE D  
LATERAL PIVOT DOOR D  
DREH-SCHIEBEFLÜGEL D

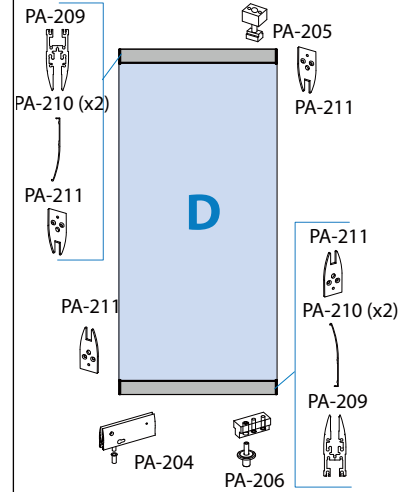



  
**MORESCHI**  
made in Italy COLLEZIONI

**COLLEZIONI**  
ET PLASTICITÀ  
↓  
FERRARI GALLO

SCORREVOLI A PARCHEGGIO  
SLIDING STACKING SYSTEMS

## PA-300 PARK LINE 2

SCORREVOLI A PARCHEGGIO / SLIDING STACKING SYSTEMS / GANZGLAS-SCHIEBEWANDSYSTEME

- Sistema scorrevole a parcheggio con profili fermavetro su misura richiesta dal cliente, senza fori nel vetro e con possibilità di porta centrale a battente e parcheggiabile.
- Sliding stacking system with glass fixing profiles made to measure upon client's request, no need to make holes in the glass and with the possibility of hinged and parkable center panel.
- Schiebesystem mit Parkraum, mit kundenspezifischen Glasleistenprofile mit zentraler Drehtür und Parkmöglichkeit.

**MY METALGLAS**

€ C.15

€ C.16

SCORREVOLI A PARCHEGGIO  
SLIDING STACKING SYSTEMS

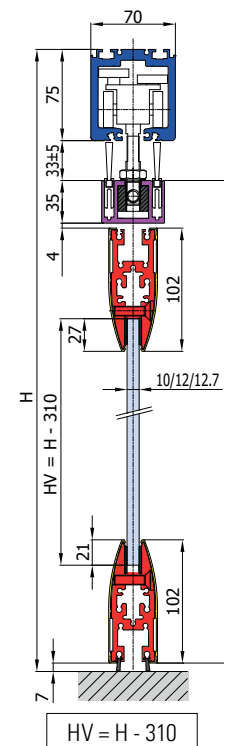
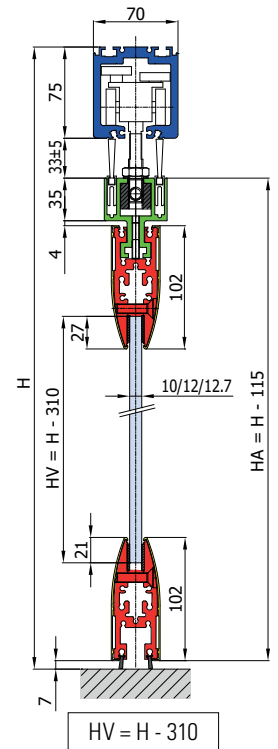
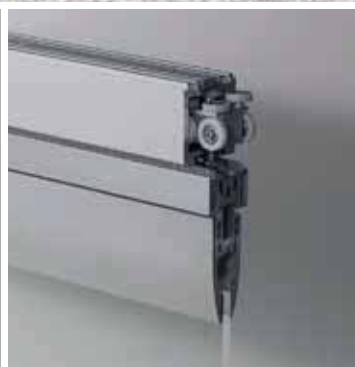

- Porta centrale scorrevole
- Center sliding pivoted door
- Dreh/pendel Schiebefügel

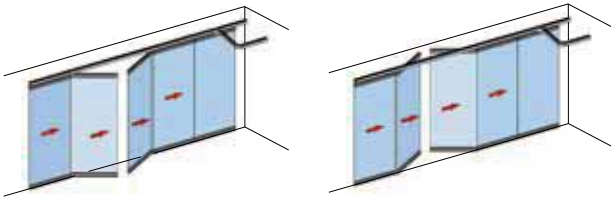

10-12-12,7	150 Kg	110 Kg	3500 550 min 1250 max
------------	--------	--------	-----------------------------

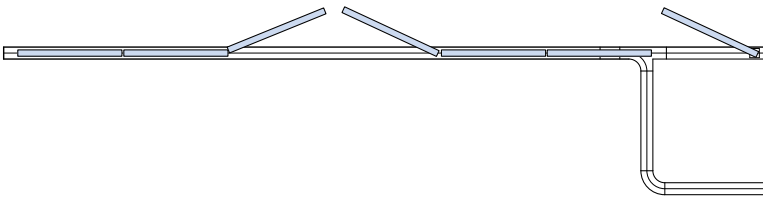

**PA-108**

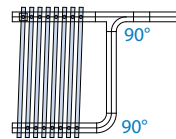

**PA-109**

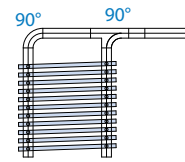

**PA-113**

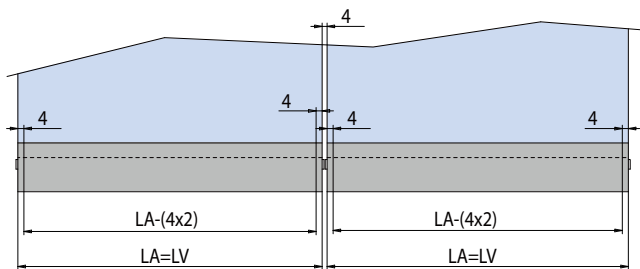
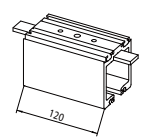

- Baie da ordinare a parte oltre alle ante, altre baie disponibili da pag. **66**
- To be ordered separately from the panels, other parking bays available from page **66**
- Neben den Flügel extra zu bestellen, andere Parkräume auf Seite **66**

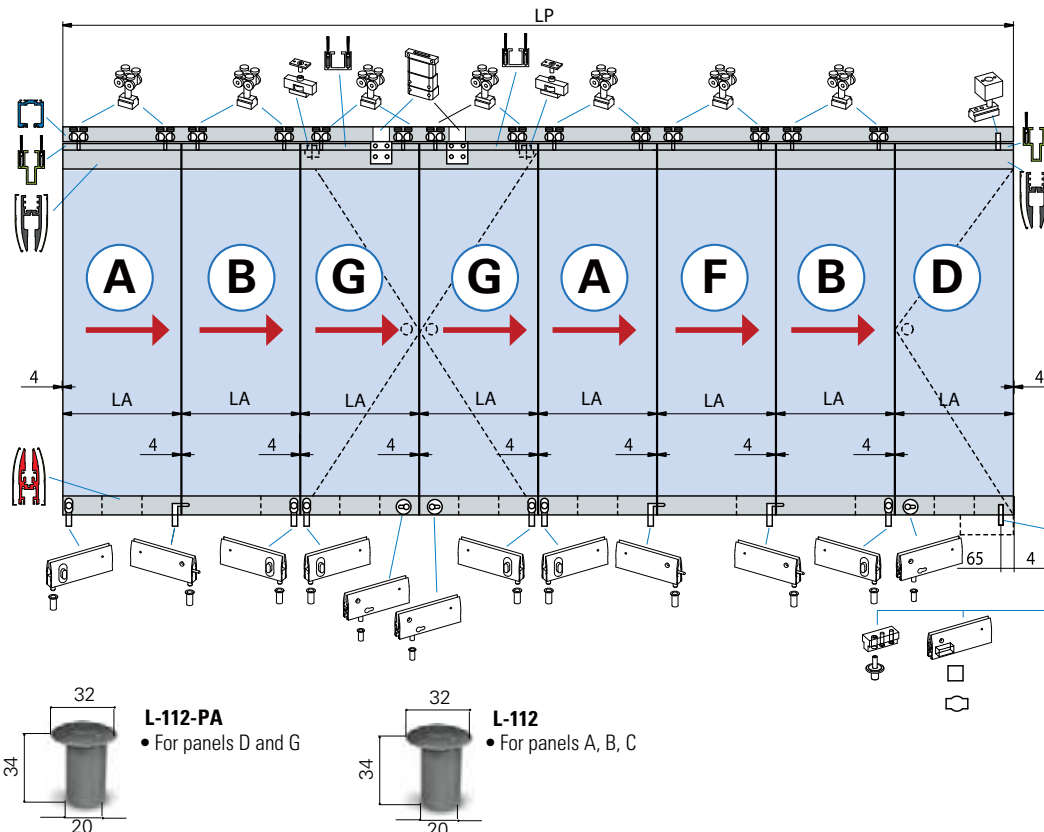

- Calcolo vetro
- Calculation glass
- Glasberechnung

At = 4 x (N + 1)  
X = LP - At  
LA = LV = X / N

- (A)**
  - Prima anta
  - First panel
  - Erster Schiebeflügel
- (B)**
  - Ultima anta
  - Last panel
  - End-Schiebeflügel
- (G)**
  - Porta centrale scorrevole dx/sx
  - Center sliding pivoted dx/sx
  - Dreh/pendel Schiebeflügel dx/sx
- (F)**
  - Anta intermedia
  - Intermediate panel
  - Zwischen-Schiebeflügel
- (D)**
  - Porta laterale
  - Lateral pivot door
  - Dreh-Schiebeflügel

xme295 / xla171BIS-1

<b>AN</b> Alluminio anodizzato Aluminium anodized Aluminium Silberfarbig	<b>At</b> Arie totali Total clearances Summe alle Abstände Glas/Wand	<b>N</b> Numero ante Numbers panels Anzahl der Elemente	<b>LP</b> Passaggio luce Clear opening width Lichte Durchgangsbreite	<b>LA = LV</b> Larghezza ante = Larghezza vetro Panel width = Glass width Flügelbreite = Glasbreite	<b>H</b> Altezza passaggio luce Clear opening height Lichte durchgangshöhe	<b>HV</b> Altezza vetro Glass height Glashöhe	<b>HA</b> Altezza anta Door height Tür Höhe
---	---	--	---	--	---	--	--

**PA-632**

- Scambio per convertire l'anta porta battente del PA-300 in anta scorrevole parcheggioabile tramite l'apposita chiave snodata
- Mechanism to convert the center pivoted door of PA-300 in sliding door parkable through the appropriate tool
- System um die zentrale Dreh-Tür des PA-300 in Schiebetür durch das entsprechende Werkzeug umzuwandeln

**PA-300 CHIAVE**



**PA-308**

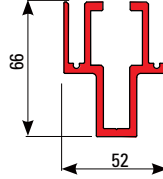

**PA-309**

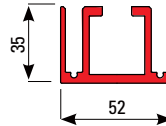

**PA-310**

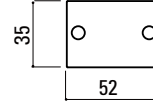

**PA-311**

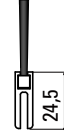

**PA-214**

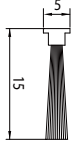

**PA-632**

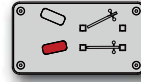
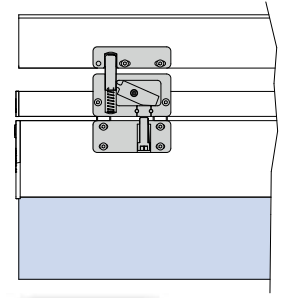
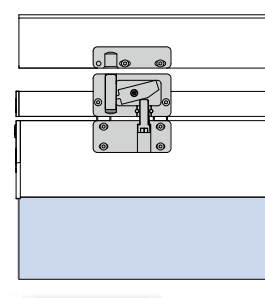
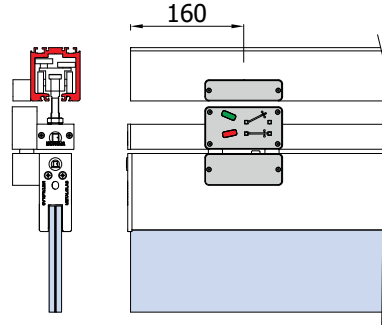
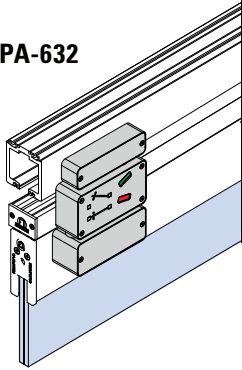

**Anta scorrevole**  
**Sliding door**



**Porta battente**  
**Pivot door**

xme527c / xme527e

**Sliding**

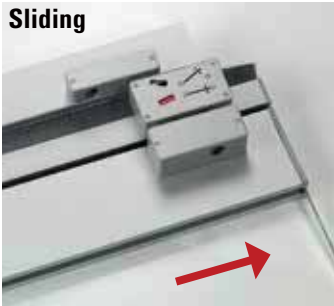

**Door**





# PA-300 PARK LINE 2

**COME USARE MY METALGLAS / HOW TO USE MY METALGLAS / WIE MAN BENUTZT MY METALGLAS**

**1** INSERIRE LE MISURE DEL TUO VANO E LE ANTE DESIDERATE  
ENTER THE MEASUREMENTS OF YOUR OPENING AND THE DOORS YOU REQUIRE  
GEBEN SIE DIE MASSE IHRER ÖFFNUNG EIN UND DIE ERFORDERLICHEN TÜREN

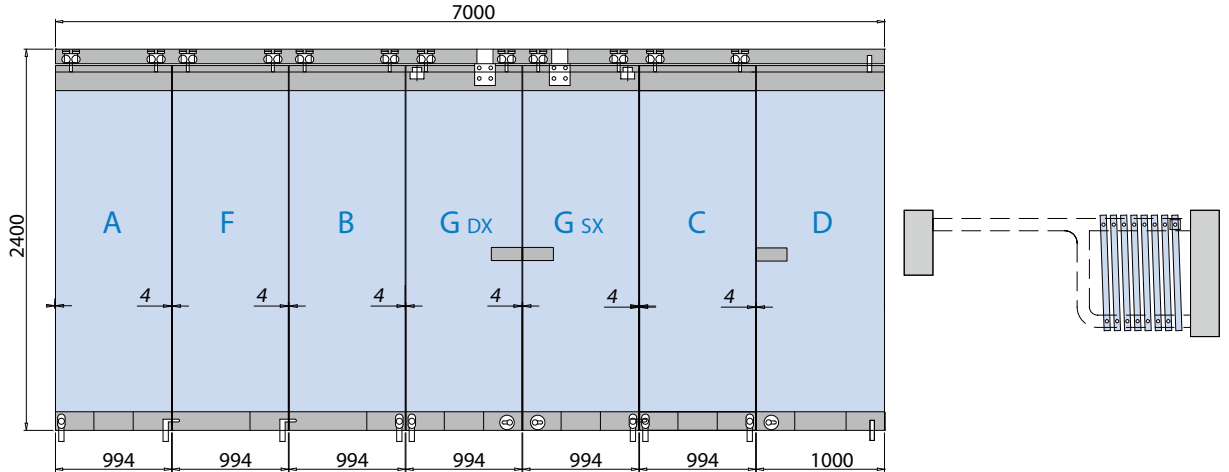

**2** SI OTTENGONO LE MISURE DEI VETRI AUTOMATICAMENTE  
THE MEASUREMENTS OF THE GLASS WILL BE GENERATED AUTOMATICALLY  
DIE ABMESSUNGEN DES GLASES WERDEN AUTOMATISCH BERECHNET

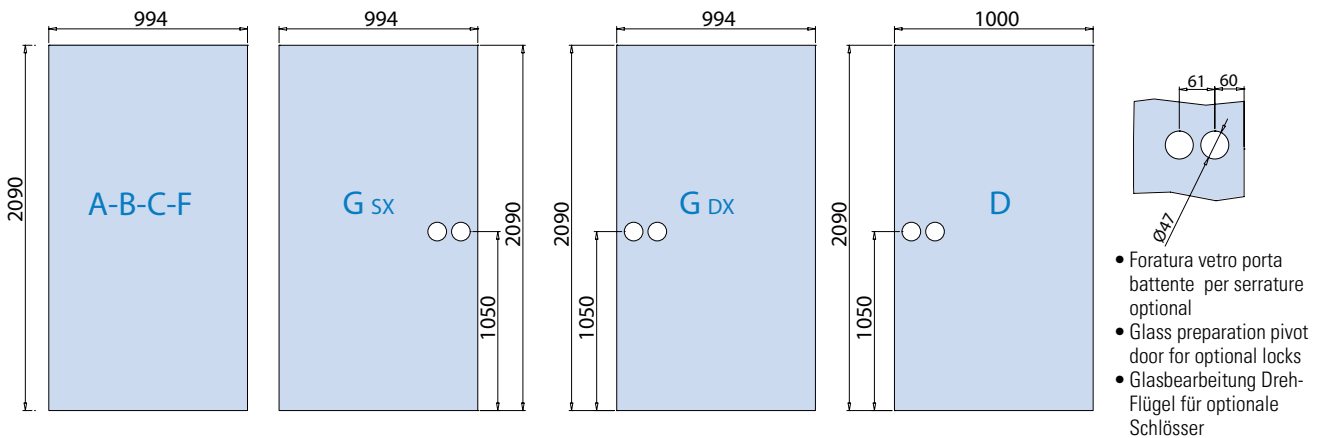

**3** SI OTTENGONO LE DISTINTE DI TAGLIO DEI PROFILI, DA ABBINARE AGLI ACCESSORI  
THE CUTTING SPECIFICATIONS OF THE PROFILES ARE OBTAINED, FOR MATCHING WITH THE ACCESSORIES  
SIE ERHALTEN EINE SPEZIFIKATION DER PROFILLÄNGEN ZUM ABGLEICHEN MIT DEM ZUBEHÖR

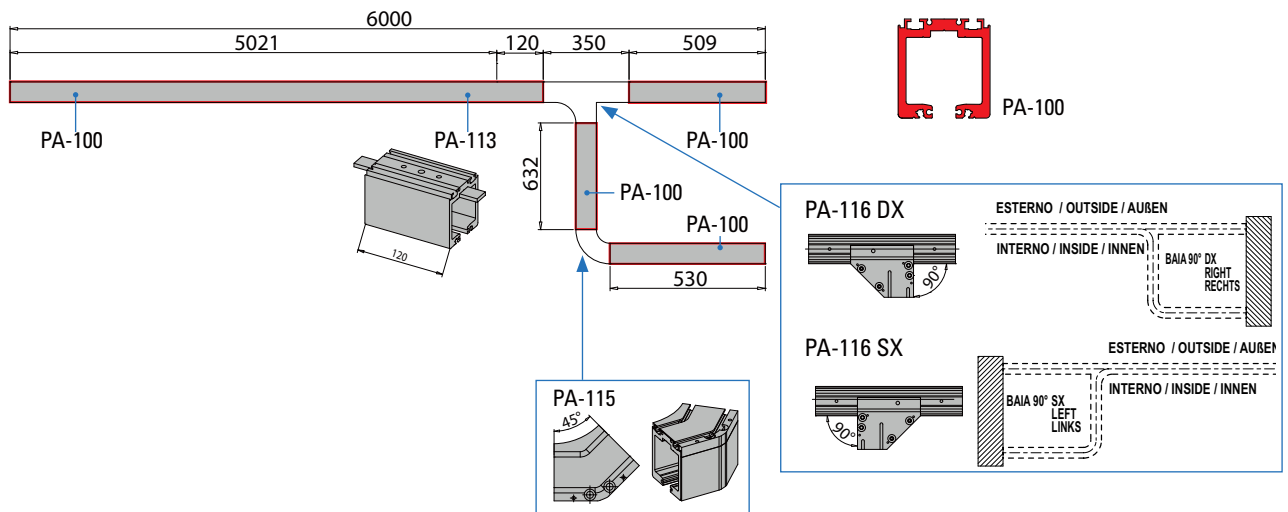



# PA-300 PARK LINE 2

## COME ASSEMBLARE LE ANTE / HOW TO ASSEMBLE THE DOORS / WIE DIE TÜREN ZUSAMMENSETZT WERDEN

TAGLIO PROFILI PROFIL PREPARATION / PROFILBEARBEITUNG		KIT ACCESSORI ACCESSORY SETS / ZUBEHÖR SETS		ANTA COMPLETA COMPLETE DOOR / KOMPLETTE TÜR
--	--	--	--	--

**ANTA A / DOOR A / TÜR A**

**PA-209 (x 2)**  
**PA-308 (x 1)**  
**PA-210 (x 4)**  
**PA-311 (x 2)**

**SUPERIORE / TOP / OBEN**

986

102

**PA-209 / PA-308 / PA-311**

**INFERIORE / BOTTOM / UNTEN**

986

250 486 250

102

**PA-225 + PA-203-POM** **PA-209** **PA-225 + PA-202-PERN**

- Lavorazione veletta con **PA-225 + PA-203-POM**
- Cover profile preparation with **PA-225 + PA-203-POM**
- Vorbereitung der Abdeckung mit **PA-225 + PA-203-POM**

14

37 37

61

INTERNO SX

**PA-300 ANTA A-10 (for glass 10 mm)**  
**PA-300 ANTA A-12 (for glass 12 - 12,7 mm)**  
 PRIMA ANTA A  
 FIRST PANEL A  
 ERSTER SCHIEBEFLÜGEL A

**PA-301 (x 2)** **PA-211 (x 3)** **PA-212 (x 1)** **PA-223 (x 20)**  
**PA-225-10 (x 4)** **PA-214 (max 2,5 mt)** **PA-314 (max 2,5 mt)** **PA-310 (x 2)**  
**PA-225-12 (x 4)** **PA-224 (x 8)** **PA-225 + PA-203-POM (x 1)**  
**L-112 (optional x 2)**

250 mm

250 mm

**PA-301** **PA-301**  
**PA-310**  
**PA-211** **PA-211**  
**PA-211**  
**PA-211**  
**PA-209** **PA-210 (x2)** **PA-211** **PA-212** **PA-210 (x2)** **PA-209**  
**PA-225 + PA-203-POM** **PA-225 + PA-202-PERN**

SCORREVOLI A PARCHEGGIO  
 SLIDING STACKING SYSTEMS

**ANTA B / DOOR B / TÜR B**

**PA-209 (x 2)**  
**PA-308 (x 1)**  
**PA-210 (x 4)**  
**PA-311 (x 2)**

**SUPERIORE / TOP / OBEN**

986

102

**PA-209 / PA-308 / PA-311**

**INFERIORE / BOTTOM / UNTEN**

986

736 250

102

**PA-209** **PA-225 + PA-203-POM**

- Lavorazione veletta con **PA-225 + PA-203-POM**
- Cover profile preparation with **PA-225 + PA-203-POM**
- Vorbereitung der Abdeckung mit **PA-225 + PA-203-POM**

14

37 37

61

INTERNO SX

**PA-300 ANTA B-10 (for glass 10 mm)**  
**PA-300 ANTA B-12 (for glass 12 - 12,7 mm)**  
 ULTIMA ANTA B  
 LAST PANEL B  
 END-SCHIEBEFLÜGEL B

**PA-301 (x 2)** **PA-211 (x 3)** **PA-212 (x 1)** **PA-223 (x 20)**  
**PA-225-10 (x 4)** **PA-214 (max 2,5 mt)** **PA-314 (max 2,5 mt)** **PA-310 (x 2)**  
**PA-225-12 (x 4)** **PA-224 (x 4)** **PA-225 + PA-203-POM (x 1)**  
**L-112 (optional x 2)**

250 mm

**PA-301** **PA-301**  
**PA-310**  
**PA-211** **PA-211**  
**PA-211**  
**PA-211**  
**PA-209** **PA-210 (x2)** **PA-211** **PA-212** **PA-210 (x2)** **PA-209**  
**PA-225 + PA-203-POM**

**ANTA F / DOOR F / TÜR F**

**PA-209 (x 2)**  
**PA-308 (x 1)**  
**PA-210 (x 4)**  
**PA-311 (x 2)**

**SUPERIORE / TOP / OBEN**

986

102

**PA-209 / PA-308 / PA-311**

**INFERIORE / BOTTOM / UNTEN**

986

736 250

102

**PA-209** **PA-225 + PA-202-PERN**

**PA-300 ANTA F-10 (for glass 10 mm)**  
**PA-300 ANTA F-12 (for glass 12 - 12,7 mm)**  
 ANTA INTERMEDIA F  
 INTERMEDIATE PANEL F / ZWISCHEN-SCHIEBEFLÜGEL F

**PA-301 (x 2)** **PA-211 (x 3)** **PA-212 (x 1)** **PA-223 (x 20)**  
**PA-225-10 (x 4)** **PA-214 (max 2,5 mt)** **PA-314 (max 2,5 mt)** **PA-310 (x 2)**  
**PA-225-12 (x 4)** **PA-224 (x 4)** **PA-225 + PA-202-PERN (x 1)**  
**L-112 (optional x 1)**

250 mm

**PA-301** **PA-301**  
**PA-310**  
**PA-211** **PA-211**  
**PA-211**  
**PA-211**  
**PA-209** **PA-210 (x2)** **PA-211** **PA-212** **PA-210 (x2)** **PA-209**  
**PA-225 + PA-202-PERN**

# PA-300 PARK LINE 2

## COME ASSEMBLARE LE ANTE / HOW TO ASSEMBLE THE DOORS / WIE DIE TÜREN ZUSAMMENSETZT WERDEN

TAGLIO PROFILI  
PROFIL PREPARATION / PROFILBEARBEITUNG



KIT ACCESSORI  
ACCESSORY SETS / ZUBEHÖR SETS



ANTA COMPLETA  
COMPLETE DOOR / KOMPLETTE TÜR

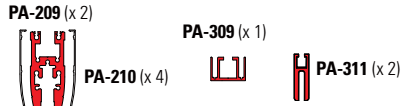

SUPERIORE / TOP / OBEN

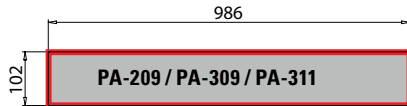

INFERIORE / BOTTOM / UNTEN

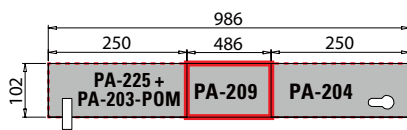

- Lavorazione veletta PA-210 con PA-204 e PA-225 + PA-203-POM
- Cover profile preparation PA-210 with PA-204 and PA-225 + PA-203-POM
- Vorbereitung der Abdeckung PA-210 mit PA-204 und PA-225 + PA-203-POM

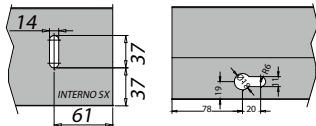

PA-300 ANTA G-10 (for glass 10 mm)  
PA-300 ANTA G-12 (for glass 12 - 12,7 mm)  
PORTA CENTRALE SCORREVOLE G  
CENTER SLIDING PIVOTED DOOR G  
DREH/PENDEL SCHIEBEFLÜGEL G

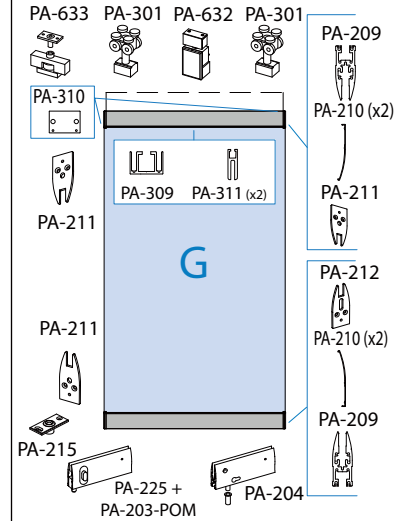

ANTA G / DOOR G / TÜR G

- Lavorazione profili PA-209 / PA-309
- Profiles preparation PA-209 / PA-309
- Vorbereitung der Profile PA-209 / PA-309

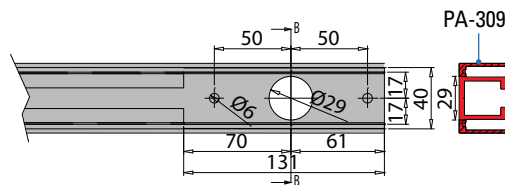
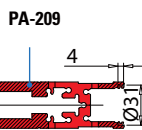
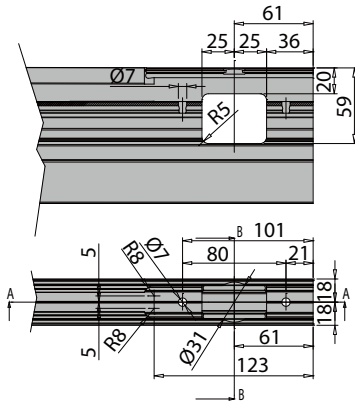

ANTA C / DOOR C / TÜR C

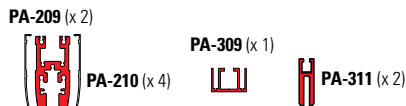

SUPERIORE / TOP / OBEN

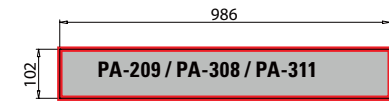

INFERIORE / BOTTOM / UNTEN

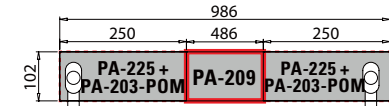

- Lavorazione veletta con PA-225 + PA-203-POM
- Cover profile preparation with PA-225 + PA-203-POM
- Vorbereitung der Abdeckung mit PA-225 + PA-203-POM

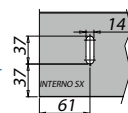

PA-300 ANTA C-10 (for glass 10 mm)  
PA-300 ANTA C-12 (for glass 12 - 12,7 mm)  
ANTA INTERMEDIA 2 C  
INTERMEDIATE PANEL 2 C  
ZWISCHEN-SCHIEBEFLÜGEL 2 C

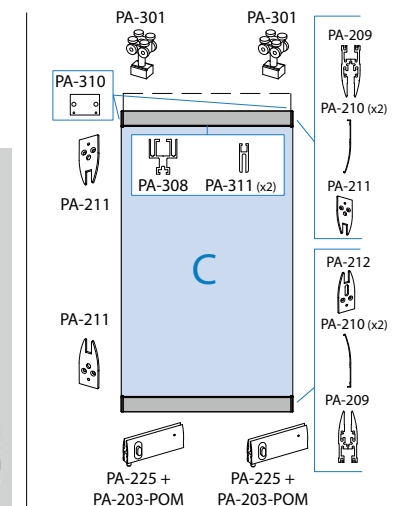
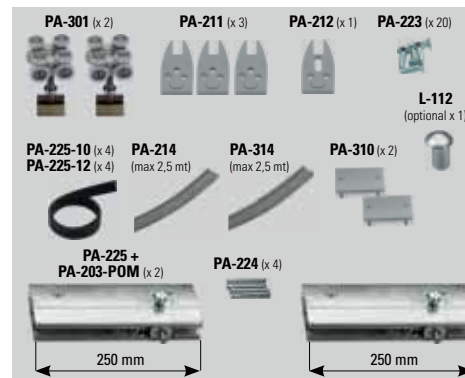

# PA-300 PARK LINE 2

## COME ASSEMBLARE LE ANTE / HOW TO ASSEMBLE THE DOORS / WIE DIE TÜREN ZUSAMMENSETZT WERDEN

<b>TAGLIO PROFILI</b> PROFIL PREPARATION / PROFILBEARBEITUNG		<b>KIT ACCESSORI</b> ACCESSORY SETS / ZUBEHÖR SETS		<b>ANTA COMPLETA</b> COMPLETE DOOR / KOMPLETTE TÜR
---	--	---	--	---

**ANTA D / DOOR D / TÜR D**

**PA-209 (x 2)**  
**PA-210 (x 4)**  
**PA-308 (x 1)**  
**PA-311 (x 2)**

**SUPERIORE / TOP / OBEN**

**INFERIORE / BOTTOM / UNTEN**

- Lavorazione veletta PA-210 con PA-204
- Cover profile preparation PA-210 with PA-204
- Vorbereitung der Abdeckung PA-210 mit PA-204

**PA-300 ANTA D-10 (for glass 10 mm)**  
**PA-300 ANTA D-12 (for glass 12 - 12,7 mm)**  
 PORTA LATERALE D  
 LATERAL PIVOT DOOR D  
 DREH-SCHIEBEFLÜGEL D

250 mm

xme540-a

 SCORREVOLI A PARCHEGGIO  
 SLIDING STACKING SYSTEMS

## PA-230

SCORREVOLI A PARCHEGGIO / SLIDING STACKING SYSTEMS / GANZGLAS-SCHIEBEWANDSYSTEME

- Sistema scorrevole a parcheggio con profili fermavetro su misura richiesta dal cliente, senza fori nel vetro e con possibilità di porta centrale a battente e parcheggiabile.
- Sliding stacking system with glass fixing profiles made to measure upon client's request, no need to make holes in the glass and with the possibility of hinged and parkable center panel.
- Schiebesystem mit Parkraum, mit kundenspezifischen Glasleistenprofile mit zentraler Drehtür und Parkmöglichkeit.

**MY METALGLAS**

€ C.34

€ C.35

SCORREVOLI A PARCHEGGIO  
SLIDING STACKING SYSTEMS

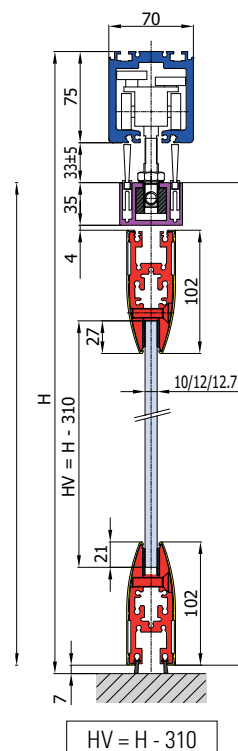
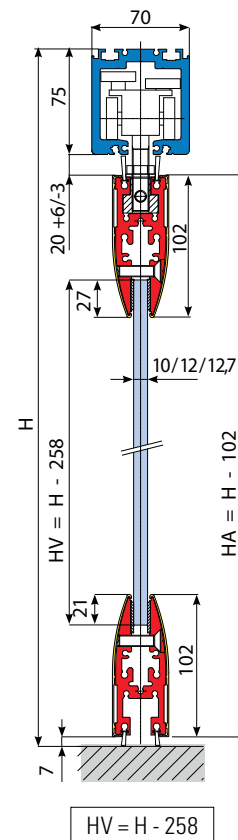

- Porta centrale scorrevole
- Center sliding pivoted door
- Dreh/pendel Schiebefügel



# PA-700 PARK do-it-yourself

SCORREVOLI A PARCHEGGIO / SLIDING STACKING SYSTEMS / GANZGLAS-SCHIEBEWANDSYSTEME

MY METALGLAS

€ C.53

NEW

SCORREVOLI A PARCHEGGIO  
SLIDING STACKING SYSTEMS



- Sistema scorrevole a parcheggio con profili fermavetro continui a misura standard (mm 1000 da tagliare secondo necessità (a carico del cliente), completi di catenaccioli ferma-anta a posizionamento esterno regolabile. Vantaggi di una consegna più veloce e di un unico prodotto a magazzino per tutte le misure fino a 1000 mm.
- Modular sliding stacking system with continuous glass fixing profiles of a standard size (mm 1000) to be cut on the basis of client's requirements comes equipped with an adjustable door holding latch positioned externally. The advantage of this product is quick delivery and a unique product available in the warehouse for all sizes up to 1000 mm.
- Schiebesystem mit Parkraum, durchgehenden Laufschiene-Profilen in Standardgröße (1000 mm), ablängbar, komplett mit äußerem einstellbaren Riegeln zur Flügelbefestigung. Vorteile einer raschen Lieferung und eines einzigen lagermäßigen Produktes mit Abmessungen bis 1000 mm.

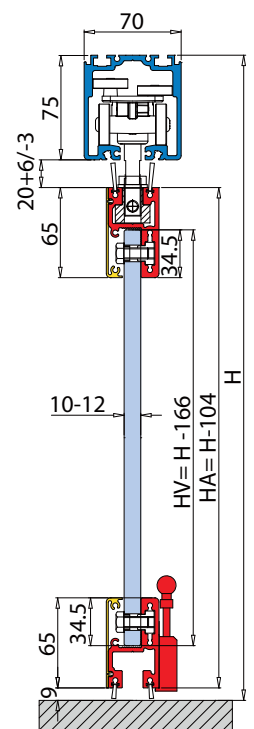

HV = H - 166

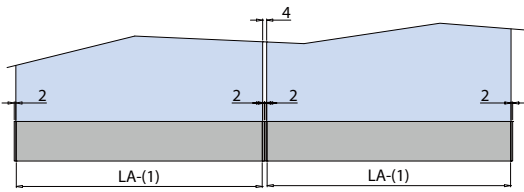
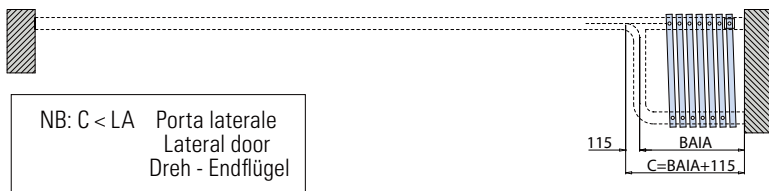
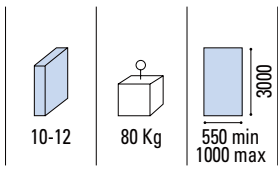
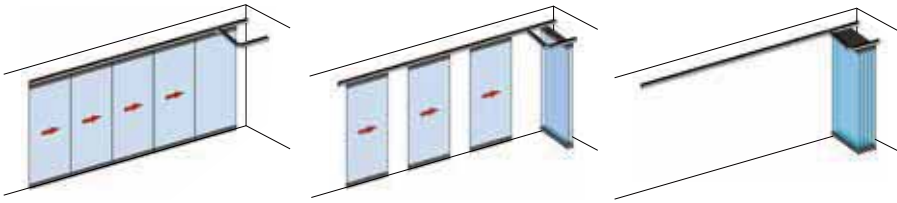

**PA-108**

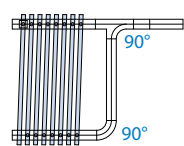

**PA-109**

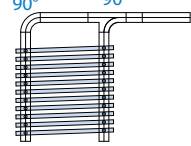

**PA-113**

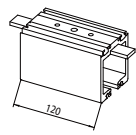

**L-112-PA**

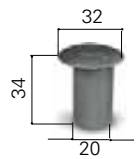

- Baie da ordinare a parte oltre alle ante, altre baie disponibili da pag. 66
- To be ordered separately from the panels, other parking bays available from page 66
- Neben den Flügel extra zu bestellen, andere Parkräume auf Seite 66

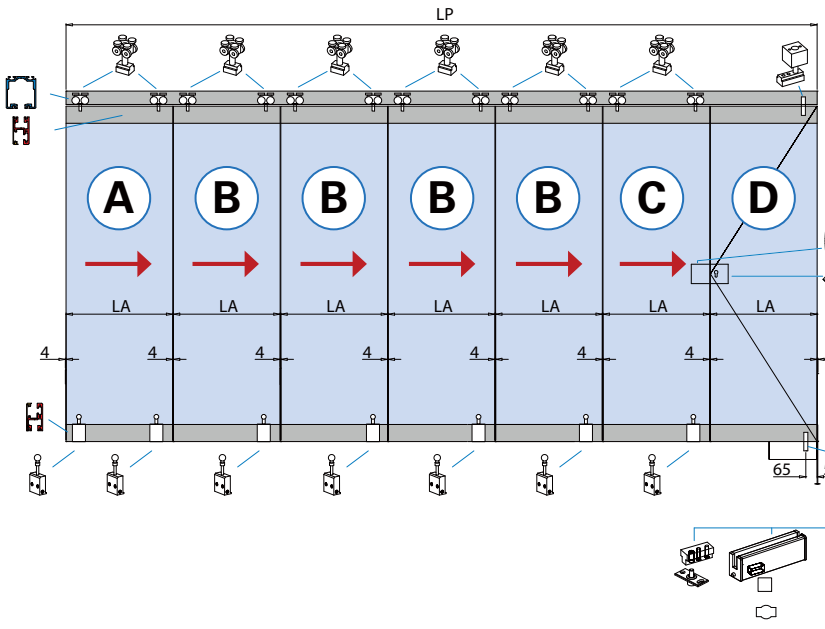

- Calcolo vetro
- Calculation glass
- Glasberechnung

$At = 4 \times (N + 1)$   
 $X = LP - At$   
 $LA = X / N$

LAVORAZIONE VETRO  
 GLASS PREPARATION  
 GLASBEARBEITUNG

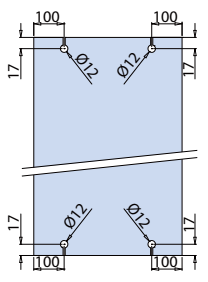

- Porta laterale fissa
- Lateral fixed door
- Dreh Flügel
- Prima anta
- First panel
- Erster Schiebeflügel
- Anta intermedia
- Intermediate panel
- Zwischen-Schiebeflügel
- Ultima anta
- Last panel
- End-Schiebeflügel

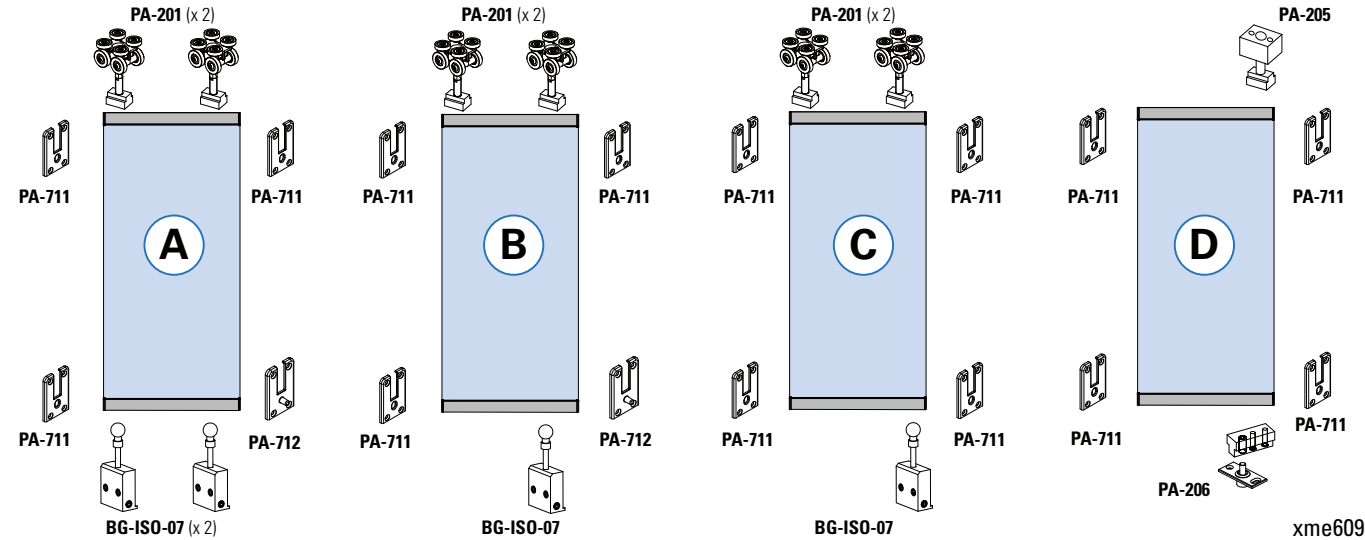
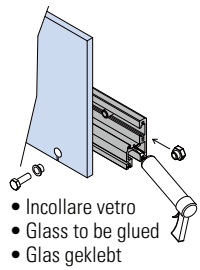

AN	At	N	LP	LA = LV	H	HV	HA
Alluminio anodizzato Aluminium anodized Aluminium Silberfarbig	Arie totali Total clearances Summe alle Abstände Glas/Wand	Numero ante Numbers panels Anzahl der Elemente	Passaggio luce Clear opening width Lichte Durchgangsbreite	Larghezza ante = Larghezza vetro Panel width = Glass width Flügelbreite = Glasbreite	Altezza passaggio luce Clear opening height Lichte durchgangshöhe	Altezza vetro Glass height Glashöhe	Altezza anta Door height Tür Höhe

# PA-700 PARK do-it-yourself

COME USARE **MY METALGLAS** / HOW TO USE **MY METALGLAS** / WIE MAN BENUTZT **MY METALGLAS**

**1** INSERIRE LE MISURE DEL TUO VANO E LE ANTE DESIDERATE  
ENTER THE MEASUREMENTS OF YOUR OPENING AND THE DOORS YOU REQUIRE  
GEBEN SIE DIE MASSE IHRER ÖFFNUNG EIN UND DIE ERFORDERLICHEN TÜREN

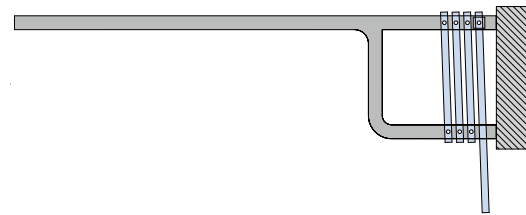
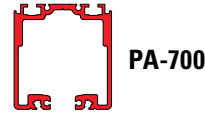
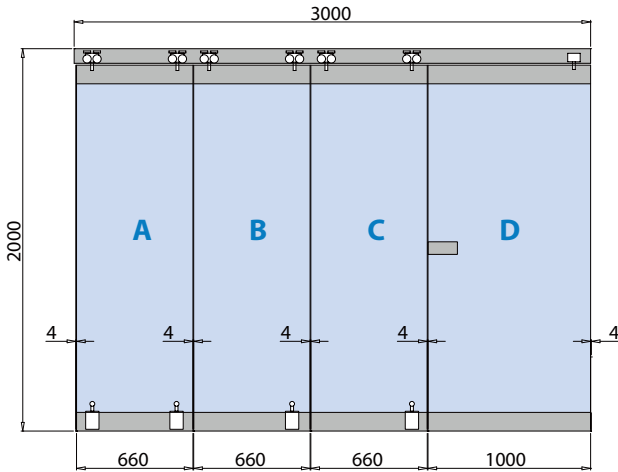

**2** SI OTTENGONO LE MISURE DEI VETRI AUTOMATICAMENTE  
THE MEASUREMENTS OF THE GLASS WILL BE GENERATED AUTOMATICALLY  
DIE ABMESSUNGEN DES GLASES WERDEN AUTOMATISCH BERECHNET

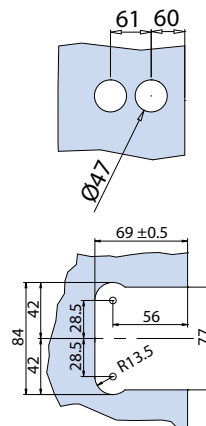
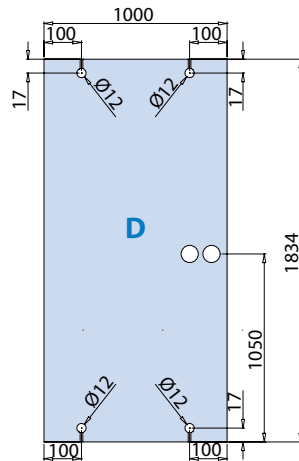
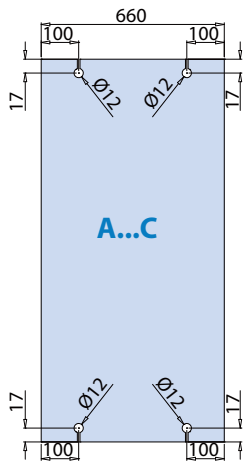

- Foratura vetro porta battente per serrature orizzontali optional
- Glass preparation pivot door for optional horizontal locks
- Glasbearbeitung Dreh-Flügel für optionale horizontale Schlösser

- Foratura vetro porta battente per serrature optional V-504, V-505, V-518, V-519, V-520
- Glass preparation pivot door for optional locks V-504, V-505, V-518, V-519, V-520
- Glasbearbeitung Dreh-Flügel für optionale Schlösser V-504, V-505, V-518, V-519, V-520

**3** SI OTTENGONO LE DISTINTE DI TAGLIO DEI PROFILI, DA ABBINARE AGLI ACCESSORI  
THE CUTTING SPECIFICATIONS OF THE PROFILES ARE OBTAINED, FOR MATCHING WITH THE ACCESSORIES  
SIE ERHALTEN EINE SPEZIFIKATION DER PROFILLÄNGEN ZUM ABGLEICHEN MIT DEM ZUBEHÖR

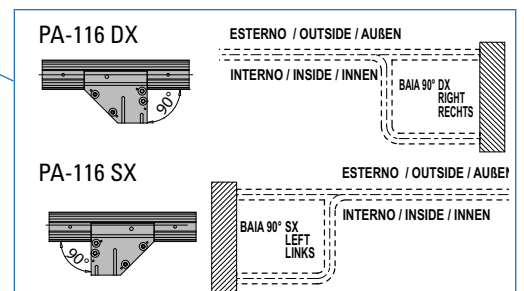
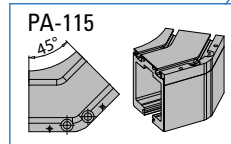
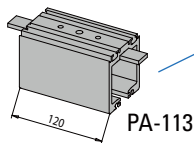
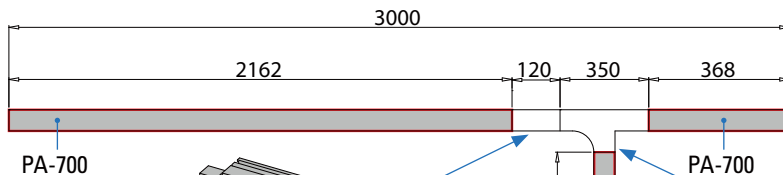



# PA-700 PARK do-it-yourself

## COME ASSEMBLARE LE ANTE / HOW TO ASSEMBLE THE DOORS / WIE DIE TÜREN ZUSAMMENSETZT WERDEN

TAGLIO PROFILI PROFIL PREPARATION / PROFILBEARBEITUNG		KIT ACCESSORI ACCESSORY SETS / ZUBEHÖR SETS		ANTA COMPLETA COMPLETE DOOR / KOMPLETTE TÜR
<p><b>ANTA A / DOOR A / TÜRA</b></p> <p>PA-730 (x 2)</p> <p><b>SUPERIORE + INFERIORE</b> / TOP + BOTTOM / OBEN + UNTEN</p>	<p><b>PA-700 ANTA A</b> (for glass 10/12 mm)                  PRIMA ANTA A                  FIRST PANEL A                  ERSTER SCHIEBEFLÜGEL A</p>			

<p><b>ANTA B / DOOR B / TÜRB</b></p> <p>PA-730 (x 2)</p> <p><b>SUPERIORE + INFERIORE</b> / TOP + BOTTOM / OBEN + UNTEN</p>	<p><b>PA-700 ANTA B</b> (for glass 10/12 mm)                  ANTA INTERMEDIA B                  INTERMEDIATE PANEL B                  ZWISCHEN-SCHIEBEFLÜGEL B</p>	
--	---	--

<p><b>ANTA C / DOOR C / TÜRC</b></p> <p>PA-730 (x 2)</p> <p><b>SUPERIORE + INFERIORE</b> / TOP + BOTTOM / OBEN + UNTEN</p>	<p><b>PA-700 ANTA C</b> (for glass 10/12 mm)                  ULTIMA ANTA C                  LAST PANEL C                  END-SCHIEBEFLÜGEL C</p>	
--	--	--

 SCORREVOLI A PARCHEGGIO  
 SLIDING STACKING SYSTEMS

# PA-700 PARK do-it-yourself

**COME ASSEMBLARE LE ANTE / HOW TO ASSEMBLE THE DOORS / WIE DIE TÜREN ZUSAMMENSETZT WERDEN**

**TAGLIO PROFILI**  
PROFIL PREPARATION / PROFILBEARBEITUNG



**KIT ACCESSORI**  
ACCESSORY SETS / ZUBEHÖR SETS



**ANTA COMPLETA**  
COMPLETE DOOR / KOMPLETTE TÜR

PA-730 (x 2)



**SUPERIORE + INFERIORE**  
/ TOP + BOTTOM / OBEN + UNTEN

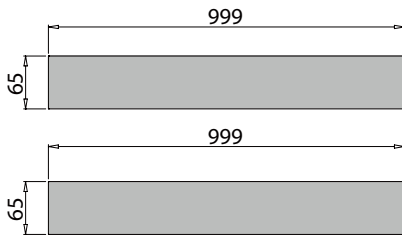

**PA-700 ANTA D** (for glass 10 / 12 mm)  
PORTA LATERALE D  
LATERAL PIVOT DOOR D  
DREH-SCHIEBEFLÜGEL D

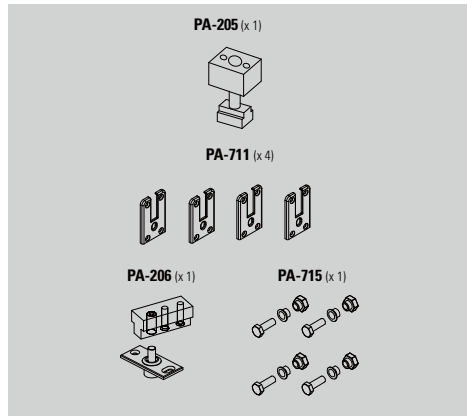

PA-205 (x 1)

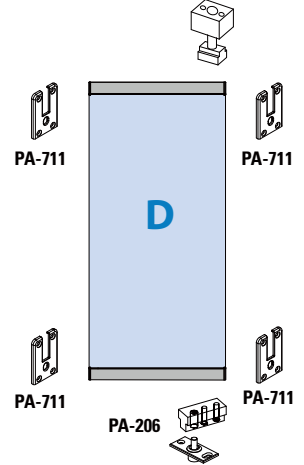

xme609d

SCORREVOLI A PARCHEGGIO  
SLIDING STACKING SYSTEMS

ANTA D / DOOR D / TÜR D



Topping	Gluten Free	MILKSHAKE
Almonds	Chocolate Chip 6.50	Rich Vanilla 5.00 6.00
Caramel Sauce	Snickerdoodle 4.40	Nutella / Nutella Mocha 5.30 6.20
Candy Pebbles	White Chocolate 3.80	Tiramisu / Caramel Chocolate 4.30 5.00
Crunchy Bears	<b>Organic</b>	Milk Chocolate Coffee 4.60
M&Ms	Chocolate Banana 5.80	Nutella Shake 4.50
Vanilla	Rudging Awesome 5.20	Blueberry Blast 4.00 4.20
Oreo Cookies	Oatmeal Me Crazy 6.10	Bubblegum Cotton Candy 6.10 7.20
Sprinkles	Fruit Cream 7.15	Sugar Free Vanilla 6.30 7.20
Whipped Cream		The Real Sniker 5.20 6.20

# GELATO



## PA-400 PARK do-it-yourself

SCORREVOLI A PARCHEGGIO / SLIDING STACKING SYSTEMS / GANZGLAS-SCHIEBEWANDSYSTEME

MY METALGLAS

€ ► C.66

SCORREVOLI A PARCHEGGIO  
SLIDING STACKING SYSTEMS



- Sistema scorrevole modulare a parcheggio con morsetti fermavetro (mm 250) e veletta continua (mm 1200) da tagliare secondo necessità (a carico del cliente).
- Modular sliding stacking system with glass fixing clamps (mm 250) and continuous covers (mm 1200) to be cut on the basis of client's requirements.
- Modulares Schiebesystem mit Parkraum, Glashalteklammen (250 mm) mit kontinuierlicher Verkleidung (mm 1200) kundenspezifisch ablängbar.

- Vantaggi di una consegna più veloce e di un unico prodotto a magazzino per tutte le misure fino a 1200 mm.
- The advantage of this product is quick delivery and a unique product available in the warehouse for all sizes up to 1200 mm.
- Vorteile einer raschen Lieferung und eines einzigen lagermäßigen Produktes mit Abmessungen bis 1200 mm.

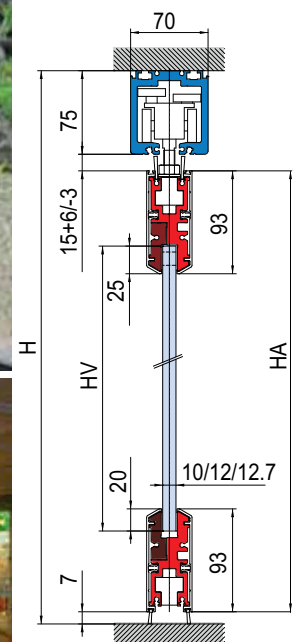
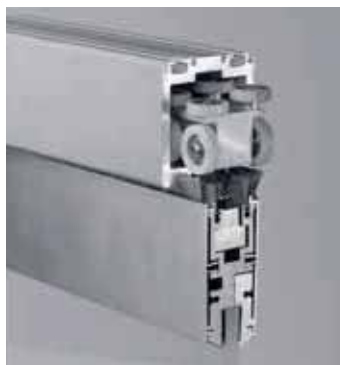

HV = H - 240  
HA = H - 100

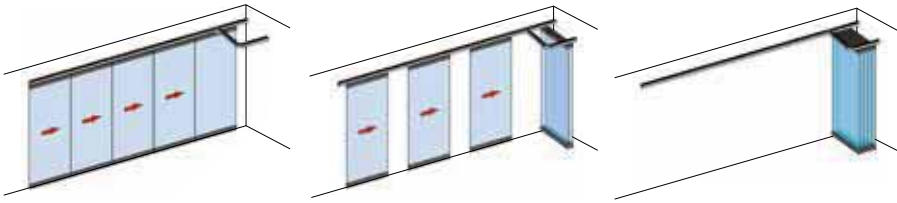

10-12-12,7	120 Kg	90 Kg	3200 550 min 1200 max
------------	--------	-------	-----------------------------

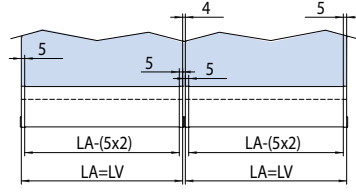
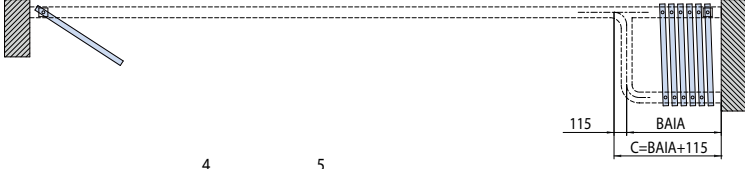

NB: C < LA Porta laterale  
Dreh - Endflügel

**PA-108**

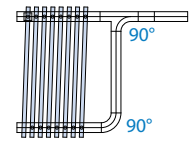

**PA-109**

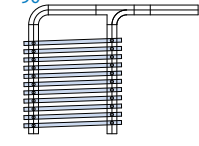

**PA-113**

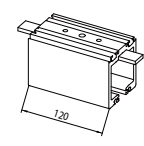

- Baie da ordinare a parte oltre alle ante, altre baie disponibili da pag. 66
- To be ordered separately from the panels, other parking bays available from page 66
- Neben den Flügel extra zu bestellen, andere Parkräume auf Seite 66

**L-112-PA**

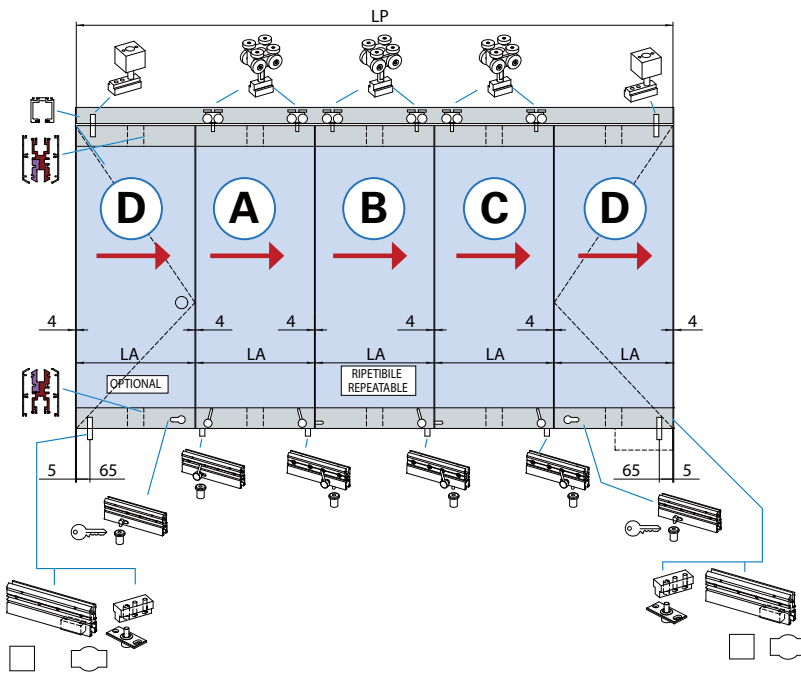

- Calcolo vetro
  - Calculation glass
  - Glasberechnung
- At = 4 x (N + 1)  
X = LP - At  
LA = LV x N

LAVORAZIONE VETRO x 2  
GLASS PREPARATION x 2  
GLASBEARBEITUNG x 2

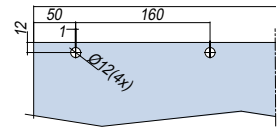

- A**
  - Prima anta
  - First panel
  - Erster Schiebeflügel
- B**
  - Anta intermedia
  - Intermediate panel
  - Zwischen-Schiebeflügel
- C**
  - Ultima anta
  - Last panel
  - End-Schiebeflügel
- D**
  - Porta laterale
  - Lateral door
  - Dreh-Schiebeflügel

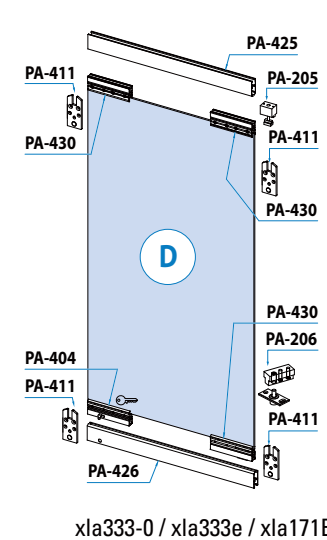
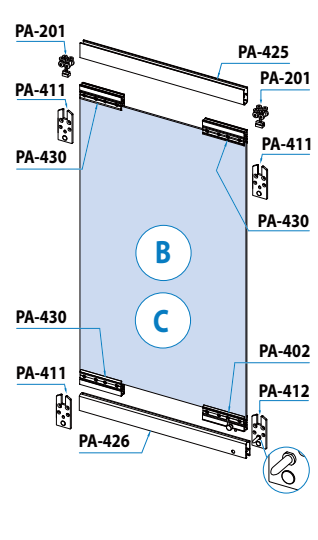
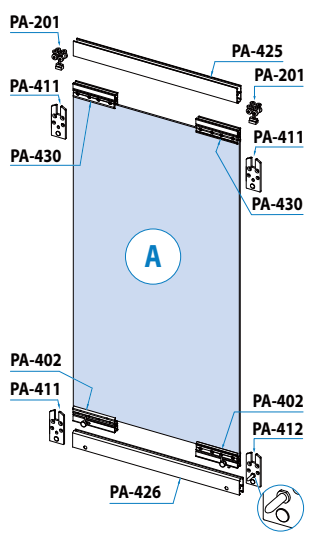

xla333-0 / xla333e / xla171BIS-1

<b>AN</b> Alluminio anodizzato Aluminium anodized Aluminium Silberfarbig	<b>At</b> Arie totali Total clearances Summe alle Abstände Glas/Wand	<b>N</b> Numero ante Numbers panels Anzahl der Elemente	<b>LP</b> Passaggio luce Clear opening width Lichte Durchgangsbreite	<b>LA = LV</b> Larghezza ante = Larghezza vetro Panel width = Glass width Flügelbreite = Glasbreite	<b>H</b> Altezza passaggio luce Clear opening height Lichte durchgangshöhe	<b>HV</b> Altezza vetro Glass height Glashöhe	<b>HA</b> Altezza anta Door height Tür Höhe
---	---	--	---	--	---	--	--

## PA-500 PARK do-it-yourself

SCORREVOLI A PARCHEGGIO / SLIDING STACKING SYSTEMS / GANZGLAS-SCHIEBEWANDSYSTEME

MY METALGLAS

€ C.79

SCORREVOLI A PARCHEGGIO  
SLIDING STACKING SYSTEMS



- Sistema scorrevole a parcheggio con profili fermavetro continui a misura standard (mm 1000 da tagliare secondo necessità (a carico del cliente), completi di catenaccioli ferma-anta a posizionamento esterno regolabile. Vantaggi di una consegna più veloce e di un unico prodotto a magazzino per tutte le misure fino a 1000 mm.
- Modular sliding stacking system with continuous glass fixing profiles of a standard size (mm 1000) to be cut on the basis of client's requirements comes equipped with an adjustable door holding latch positioned externally. The advantage of this product is quick delivery and a unique product available in the warehouse for all sizes up to 1000 mm.
- Schiebesystem mit Parkraum, durchgehenden Laufschienen-Profilen in Standardgröße (1000 mm), ablängbar, komplett mit äußerem einstellbaren Riegeln zur Flügelbefestigung. Vorteile einer raschen Lieferung und eines einzigen lagermäßigen Produktes mit Abmessungen bis 1000 mm.

- Vantaggi di una consegna più veloce e di un unico prodotto a magazzino per tutte le misure fino a 1000 mm.
- The advantage of this product is quick delivery and a unique product available in the warehouse for all sizes up to 1000 mm.
- Vorteile einer raschen Lieferung und eines einzigen lagermäßigen Produktes mit Abmessungen bis 1000 mm.

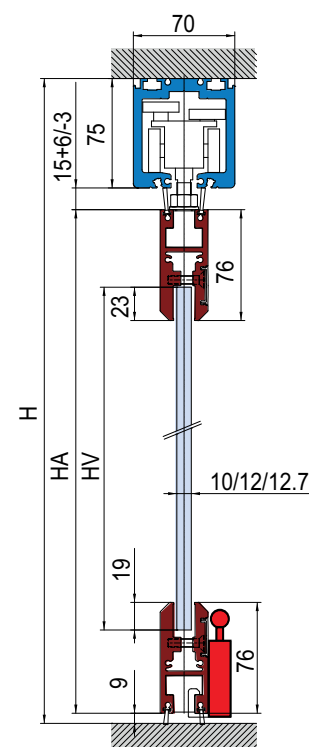

HV = H - 210  
HA = H - 100

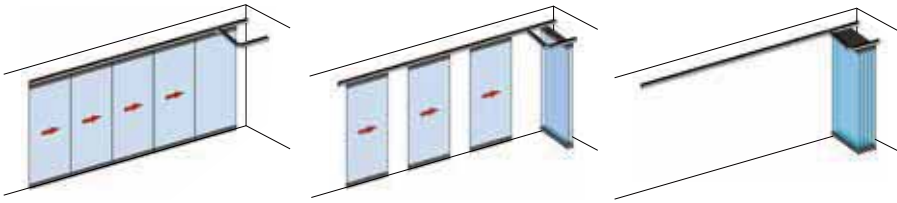

10-12-12,7	120 Kg	90 Kg	550 min 1000 max

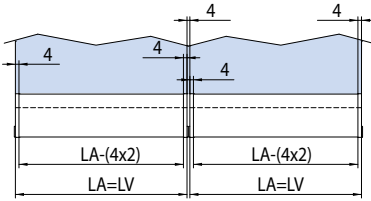
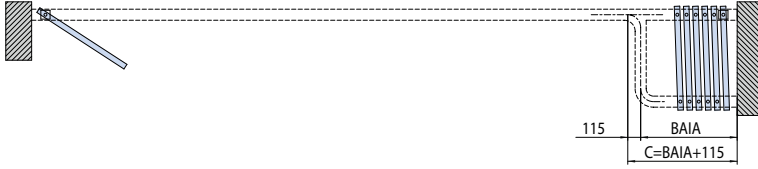

NB: C < LA Porta laterale  
Lateral door  
Dreh - Endflügel

**PA-108**

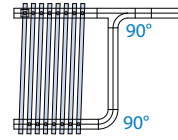

**PA-109**

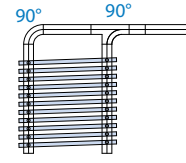

**PA-113**

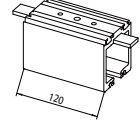

**L-112-PA**



- Baie da ordinare a parte oltre alle ante, altre baie disponibili da pag. 66
- To be ordered separately from the panels, other parking bays available from page 66
- Neben den Flügel extra zu bestellen, andere Parkräume auf Seite 66

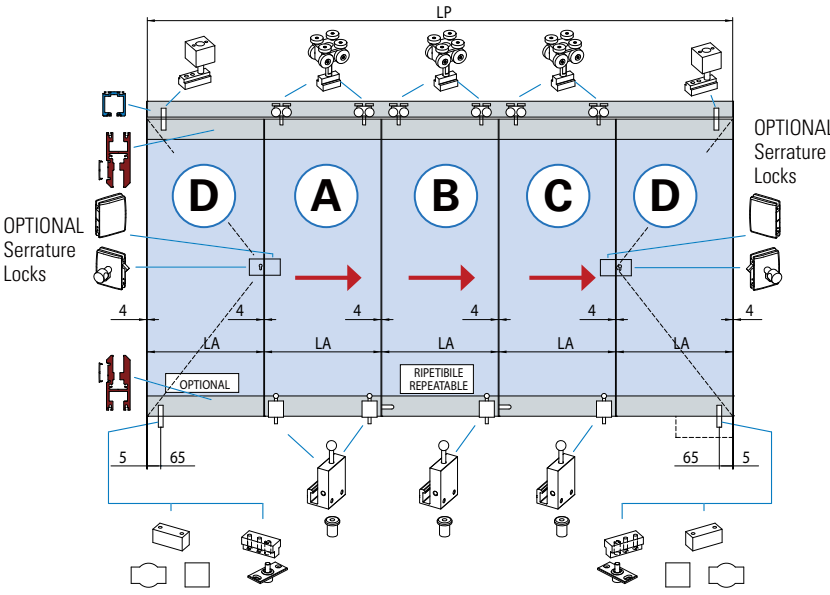

- Calcolo vetro
- Calculation glass
- Glasberechnung

At = 4 x (N + 1)  
X = LP - At  
LA = LV = X / N

- D**
  - Porta laterale fissa
  - Lateral fixed door
  - Dreh Flügel
- A**
  - Prima anta
  - First panel
  - Erster Schiebeflügel
- B**
  - Anta intermedia
  - Intermediate panel
  - Zwischen-Schiebeflügel
- C**
  - Ultima anta
  - Last panel
  - End-Schiebeflügel

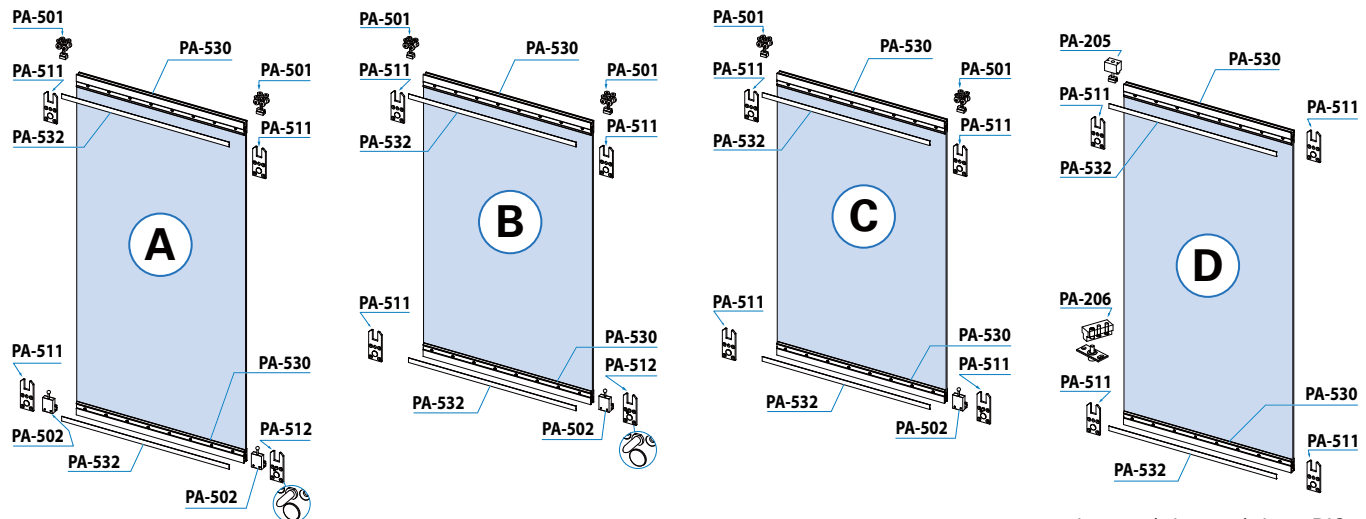

xla341-0 / xla341e / xla171BIS-1

<b>AN</b> Alluminio anodizzato Aluminium anodized Aluminium Silberfarbig	<b>At</b> Arie totali Total clearances Summe alle Abstände Glas/Wand	<b>N</b> Numero ante Numbers panels Anzahl der Elemente	<b>LP</b> Passaggio luce Clear opening width Lichte Durchgangsbreite	<b>LA = LV</b> Larghezza ante = Larghezza vetro Panel width = Glass width Flügelbreite = Glasbreite	<b>H</b> Altezza passaggio luce Clear opening height Lichte durchgangshöhe	<b>HV</b> Altezza vetro Glass height Glashöhe	<b>HA</b> Altezza anta Door height Tür Höhe
---	---	--	---	--	---	--	--

# PA-500 PARK do-it-yourself

COME USARE MY METALGLAS / HOW TO USE MY METALGLAS / WIE MAN BENUTZT MY METALGLAS

**1** INSERIRE LE MISURE DEL TUO VANO E LE ANTE DESIDERATE  
ENTER THE MEASUREMENTS OF YOUR OPENING AND THE DOORS YOU REQUIRE  
GEBEN SIE DIE MASSE IHRER ÖFFNUNG EIN UND DIE ERFORDERLICHEN TÜREN

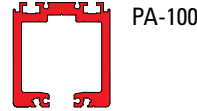
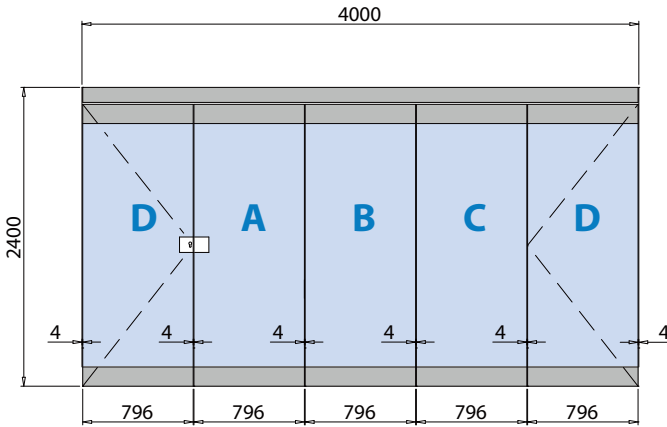

**2** SI OTTENGONO LE MISURE DEI VETRI AUTOMATICAMENTE  
THE MEASUREMENTS OF THE GLASS WILL BE GENERATED AUTOMATICALLY  
DIE ABMESSUNGEN DES GLASES WERDEN AUTOMATISCH BERECHNET

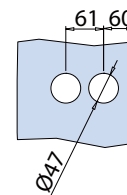
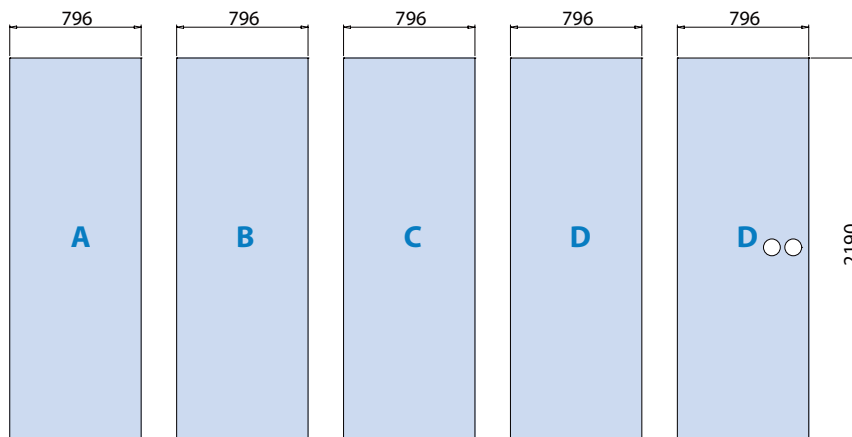

- Foratura vetro porta battente per serrature optional
- Glass preparation pivot door for optional locks
- Glasbearbeitung Dreh-Flügel für optionale Schlösser

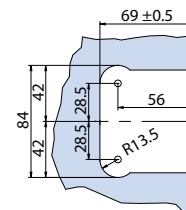

- Foratura vetro porta battente per serrature optional V-504, V-505, V-518, V-519, V-520
- Glass preparation pivot door for optional locks V-504, V-505, V-518, V-519, V-520
- Glasbearbeitung Dreh-Flügel für optionale Schlösser V-504, V-505, V-518, V-519, V-520

**3** SI OTTENGONO LE DISTINTE DI TAGLIO DEI PROFILI, DA ABBINARE AGLI ACCESSORI  
THE CUTTING SPECIFICATIONS OF THE PROFILES ARE OBTAINED, FOR MATCHING WITH THE ACCESSORIES  
SIE ERHALTEN EINE SPEZIFIKATION DER PROFILLÄNGEN ZUM ABGLEICHEN MIT DEM ZUBEHÖR

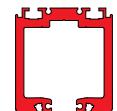
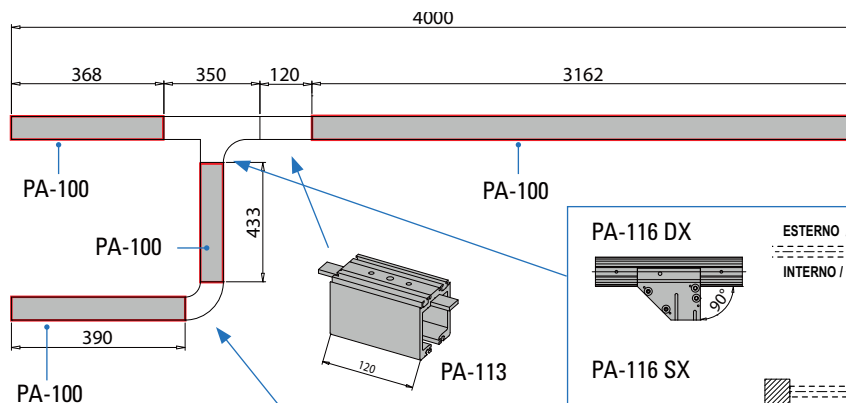

PA-100

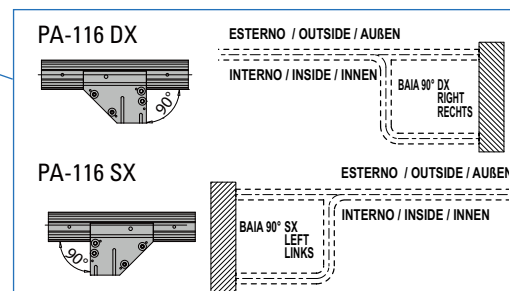
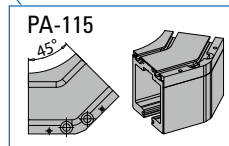



# PA-500 PARK do-it-yourself

## COME ASSEMBLARE LE ANTE / HOW TO ASSEMBLE THE DOORS / WIE DIE TÜREN ZUSAMMENSETZT WERDEN

TAGLIO PROFILI PROFIL PREPARATION / PROFILBEARBEITUNG		KIT ACCESSORI ACCESSORY SETS / ZUBEHÖR SETS		ANTA COMPLETA COMPLETE DOOR / KOMPLETTE TÜR
--	--	--	--	--

**ANTA A / DOOR A / TÜRA**

PA-530 (x 2)  
 PA-532 (x 4)

**SUPERIORE + INFERIORE**  
 / TOP + BOTTOM / OBEN + UNTEN

**PA-500 ANTA A-10** (for glass 10 mm)  
**PA-500 ANTA A-12** (for glass 12 - 12,7 mm)  
 PRIMA ANTA A  
 FIRST PANEL A  
 ERSTER SCHIEBEFLÜGEL A

SCORREVOLI A PARCHEGGIO  
SLIDING STACKING SYSTEMS

**ANTA B / DOOR B / TÜRB**

PA-530 (x 2)  
 PA-532 (x 4)

**SUPERIORE + INFERIORE**  
 / TOP + BOTTOM / OBEN + UNTEN

**PA-500 ANTA B-10** (for glass 10 mm)  
**PA-500 ANTA B-12** (for glass 12 - 12,7 mm)  
 ANTA INTERMEDIA B  
 INTERMEDIATE PANEL B  
 ZWISCHEN-SCHIEBEFLÜGEL B

**ANTA C / DOOR C / TÜRC**

PA-530 (x 2)  
 PA-532 (x 4)

**SUPERIORE + INFERIORE**  
 / TOP + BOTTOM / OBEN + UNTEN

**PA-500 ANTA C-10** (for glass 10 mm)  
**PA-500 ANTA C-12** (for glass 12 - 12,7 mm)  
 ULTIMA ANTA C  
 LAST PANEL C  
 END-SCHIEBEFLÜGEL C

# PA-500 PARK do-it-yourself

**COME ASSEMBLARE LE ANTE / HOW TO ASSEMBLE THE DOORS / WIE DIE TÜREN ZUSAMMENSETZT WERDEN**

TAGLIO PROFILI  
PROFIL PREPARATION / PROFILBEARBEITUNG



KIT ACCESSORI  
ACCESSORY SETS / ZUBEHÖR SETS



ANTA COMPLETA  
COMPLETE DOOR / KOMPLETTE TÜR

PA-530 (x 2)



PA-532 (x 4)



SUPERIORE + INFERIORE  
/ TOP + BOTTOM / OBEN + UNTEN

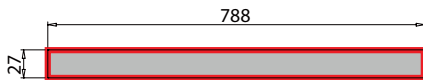
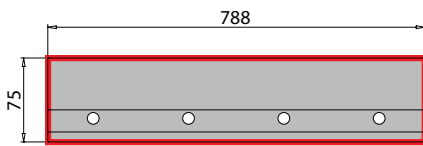

PA-500 ANTA D-10 (for glass 10 mm)  
PA-500 ANTA D-12 (for glass 12 - 12,7 mm)  
PORTA LATERALE D  
LATERAL PIVOT DOOR D  
DREH-SCHIEBEFLÜGEL D

PA-205 (x 1)



PA-523 (x 20)



PA-214  
(max 4 mt)



PA-511 (x 4)



PA-225-10 (x 4)  
PA-225-12 (x 4)



PA-206 (x 1)

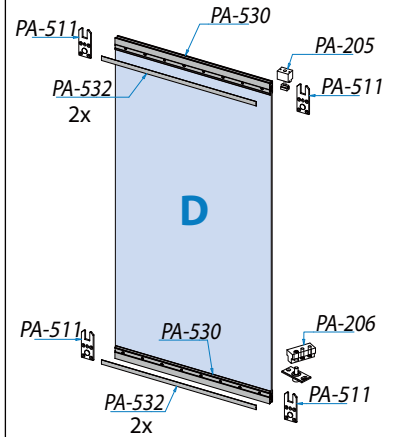

SCORREVOLI A PARCHEGGIO  
SLIDING STACKING SYSTEMS





SCORREVOLI A PARCHEGGIO  
SLIDING STACKING SYSTEMS

# PA-600 FORTI SPESSORI

SCORREVOLI A PARCHEGGIO / SLIDING STACKING SYSTEMS / GANZGLAS-SCHIEBEWANDSYSTEME

**MY METALGLAS**

€ ▶ C.93

SCORREVOLI A PARCHEGGIO  
SLIDING STACKING SYSTEMS



- Sistema scorrevole a parcheggio fornito con profili fermavetro su misura richiesta dal cliente, senza necessità di fori nel vetro.
- Sliding stacking system with glass fixing profiles made to measure upon client's request, no need to make holes in the glass.
- Schiebesystem mit Parkraum, kundenspezifische Glasleistenprofile ohne Glasbohrungen.

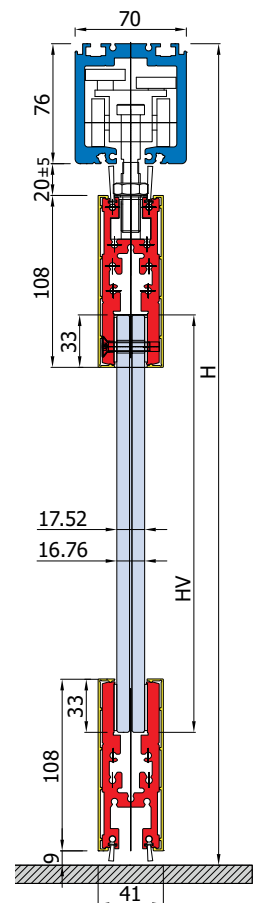

HV = H - 255

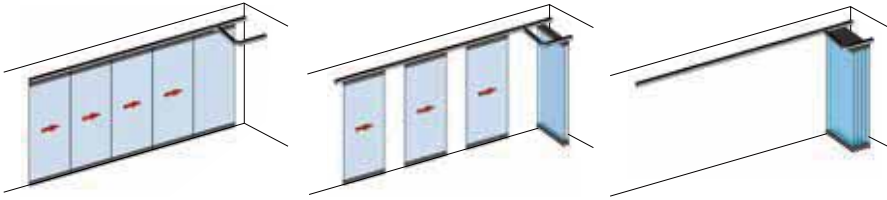

 16,76 17,52	 150 Kg	 110 Kg	 550 min 1000 max 3500
--------------------	------------	------------	---------------------------------

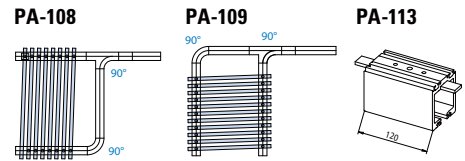
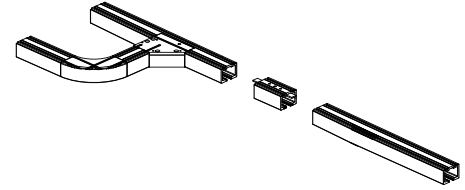
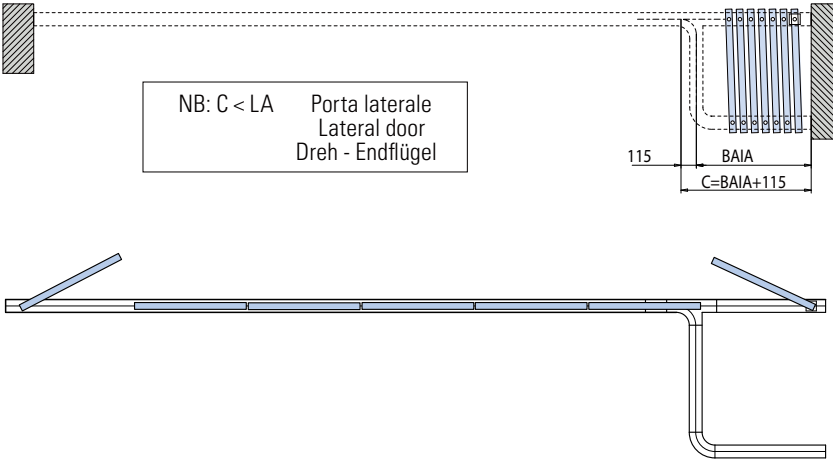

- Da ordinare a parte oltre alle ante
- To be ordered separately from the panels
- Neben den Flügeln extra zu bestellen

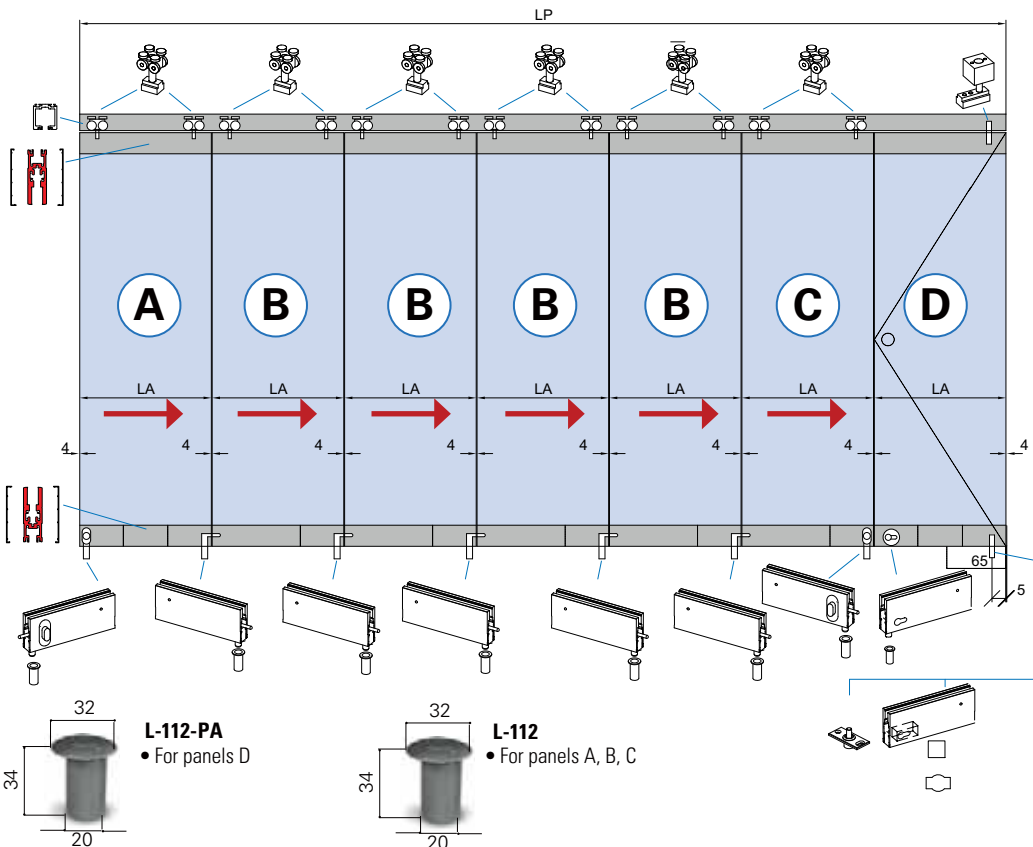
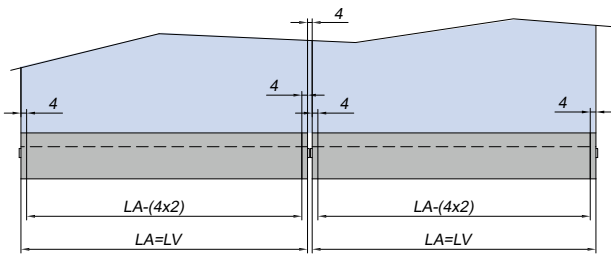

- Calcolo vetro
- Calculation glass
- Glasberechnung

$$At = 4 \times (N + 1)$$

$$X = LP - At$$

$$LA = LV = X / N$$

- (A)**
  - Prima anta
  - First panel
  - Erster Schiebeflügel
- (B)**
  - Anta intermedia
  - Intermediate panel
  - Zwischen-Schiebeflügel
- (C)**
  - Ultima anta
  - Last panel
  - End-Schiebeflügel
- (D)**
  - Porta laterale
  - Lateral pivot door
  - Dreh-Endflügel

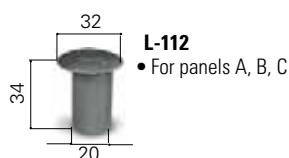

xme527b / xme527f

AN	At	N	LP	LA = LV	H	HV	HA
Alluminio anodizzato	Arie totali	Numero ante	Passaggio luce	Larghezza ante = Larghezza vetro	Altezza passaggio luce	Altezza vetro	Altezza anta
Aluminium anodized	Total clearances	Numbers panels	Clear opening width	Panel width = Glass width	Clear opening height	Glass height	Door height
Aluminium Silberfarbig	Summe alle Abstände Glas/Wand	Anzahl der Elemente	Lichte Durchgangsbreite	Flügelbreite = Glasbreite	Lichte durchgangshöhe	Glashöhe	Tür Höhe

# PA-600 FORTI SPESSORI

COME USARE MY METALGLAS / HOW TO USE MY METALGLAS / WIE MAN BENUTZT MY METALGLAS

- 1** INSERIRE LE MISURE DEL TUO VANO E LE ANTE DESIDERATE  
ENTER THE MEASUREMENTS OF YOUR OPENING AND THE DOORS YOU REQUIRE  
GEBEN SIE DIE MASSE IHRER ÖFFNUNG EIN UND DIE ERFORDERLICHEN TÜREN

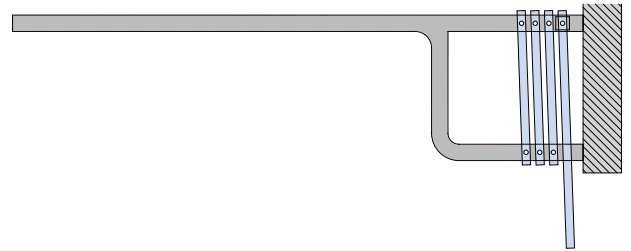
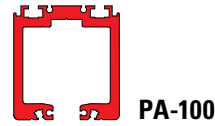
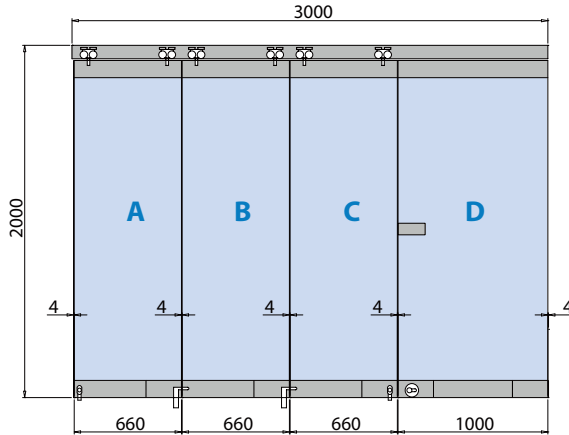

- 2** SI OTTENGONO LE MISURE DEI VETRI AUTOMATICAMENTE  
THE MEASUREMENTS OF THE GLASS WILL BE GENERATED AUTOMATICALLY  
DIE ABMESSUNGEN DES GLASES WERDEN AUTOMATISCH BERECHNET

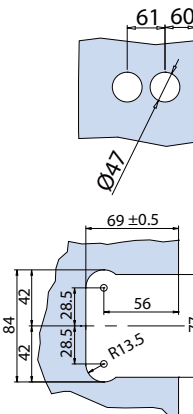
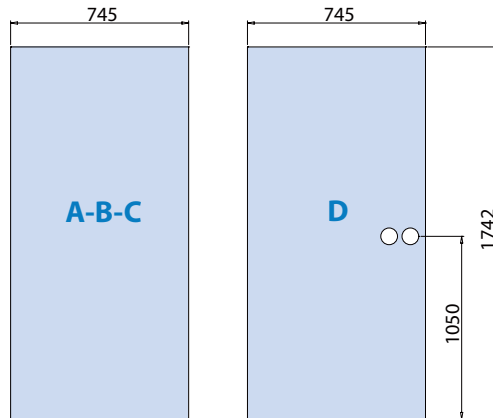

- Foratura vetro porta battente per serrature optional
- Glass preparation pivot door for optional locks
- Glasbearbeitung Dreh-Flügel für optionale Schlösser

- Foratura vetro porta battente per serrature optional V-504, V-505, V-518, V-519, V-520
- Glass preparation pivot door for optional locks V-504, V-505, V-518, V-519, V-520
- Glasbearbeitung Dreh-Flügel für optionale Schlösser V-504, V-505, V-518, V-519, V-520

- 3** SI OTTENGONO LE DISTINTE DI TAGLIO DEI PROFILI, DA ABBINARE AGLI ACCESSORI  
THE CUTTING SPECIFICATIONS OF THE PROFILES ARE OBTAINED, FOR MATCHING WITH THE ACCESSORIES  
SIE ERHALTEN EINE SPEZIFIKATION DER PROFILLÄNGEN ZUM ABGLEICHEN MIT DEM ZUBEHÖR

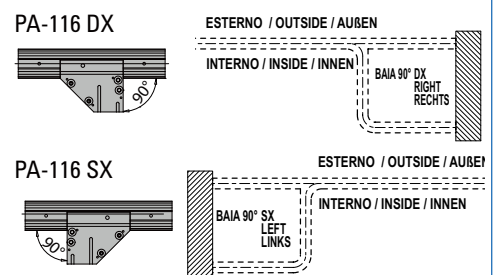
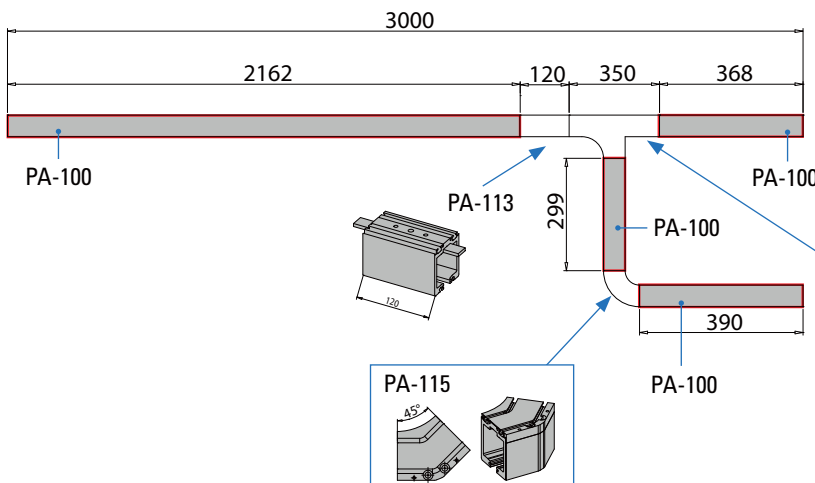

# PA-600 FORTI SPESSORI

## COME ASSEMBLARE LE ANTE / HOW TO ASSEMBLE THE DOORS / WIE DIE TÜREN ZUSAMMENSETZT WERDEN

TAGLIO PROFILI PROFIL PREPARATION / PROFILBEARBEITUNG	+	KIT ACCESSORI ACCESSORY SETS / ZUBEHÖR SETS	=	ANTA COMPLETA COMPLETE DOOR / KOMPLETTE TÜR
<p><b>ANTA A / DOOR A / TÜRA</b></p> <p>PA-609 (x 2) PA-610 (x 4)</p> <p><b>SUPERIORE / TOP / OBEN</b> 652</p> <p>102 PA-610</p> <p><b>INFERIORE / BOTTOM / UNTEN</b> 652 250 152 250</p> <p>102 PA-625 + PA-203-POM PA-609 PA-625 + PA-202-PERN</p> <ul style="list-style-type: none"> <li>Lavorazione veletta con PA-625 + PA-203-POM</li> <li>Cover profile preparation with PA-625 + PA-203-POM</li> <li>Vorbereitung der Abdeckung mit PA-625 + PA-203-POM</li> </ul>		<p><b>PA-600 ANTA A-16</b> (for glass 16,76 mm) <b>PA-600 ANTA A-17</b> (for glass 17,52 mm) PRIMA ANTA A FIRST PANEL A RSTER SCHIEBEFLÜGEL A</p>		

<p><b>ANTA B / DOOR B / TÜRB</b></p> <p>PA-609 (x 2) PA-610 (x 4)</p> <p><b>SUPERIORE / TOP / OBEN</b> 652</p> <p>102 PA-609</p> <p><b>INFERIORE / BOTTOM / UNTEN</b> 652 402 250</p> <p>102 PA-609 PA-625 + PA-202-PERN</p>	<p><b>PA-600 ANTA B-16</b> (for glass 16,76 mm) <b>PA-600 ANTA B-17</b> (for glass 17,52 mm) ANTA INTERMEDIA B INTERMEDIATE PANEL B ZWISCHEN-SCHIEBEFLÜGEL B</p>	
--	--	--

<p><b>ANTA C / DOOR C / TÜRC</b></p> <p>PA-609 (x 2) PA-610 (x 4)</p> <p><b>SUPERIORE / TOP / OBEN</b> 652</p> <p>102 PA-609</p> <p><b>INFERIORE / BOTTOM / UNTEN</b> 652 250 402</p> <p>102 PA-625 + PA-203-POM PA-609</p> <ul style="list-style-type: none"> <li>Lavorazione veletta con PA-625 + PA-203-POM</li> <li>Cover profile preparation with PA-625 + PA-203-POM</li> <li>Vorbereitung der Abdeckung mit PA-625 + PA-203-POM</li> </ul>	<p><b>PA-600 ANTA C-16</b> (for glass 16,76 mm) <b>PA-600 ANTA C-17</b> (for glass 17,52 mm) ULTIMA ANTA C LAST PANEL C END-SCHIEBEFLÜGEL C</p>	
---	---	--

# PA-600 FORTI SPESSORI

## COME ASSEMBLARE LE ANTE / HOW TO ASSEMBLE THE DOORS / WIE DIE TÜREN ZUSAMMENSETZT WERDEN

TAGLIO PROFILI  
PROFIL PREPARATION / PROFILBEARBEITUNG



KIT ACCESSORI  
ACCESSORY SETS / ZUBEHÖR SETS



ANTA COMPLETA  
COMPLETE DOOR / KOMPLETTE TÜR

SCORREVOLI A PARCHEGGIO  
SLIDING STACKING SYSTEMS

ANTA D / DOOR D / TÜRD

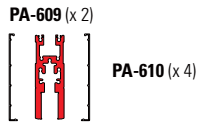

SUPERIORE / TOP / OBEN

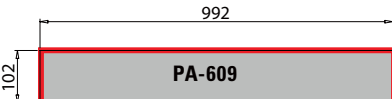

INFERIORE / BOTTOM / UNTEN

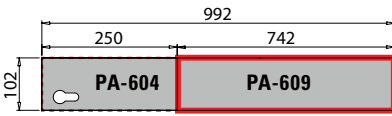

- Lavorazione veletta con PA-604
- Cover profile preparation with PA-604
- Vorbereitung der Abdeckung mit PA-604

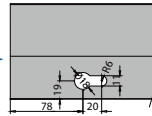

PA-600 ANTA D-16 (for glass 16,76 mm)  
PA-600 ANTA D-17 (for glass 17,52 mm)  
PORTA LATERALE D /  
LATERAL PIVOT DOOR D / DREH-SCHIEBEFLÜGEL D

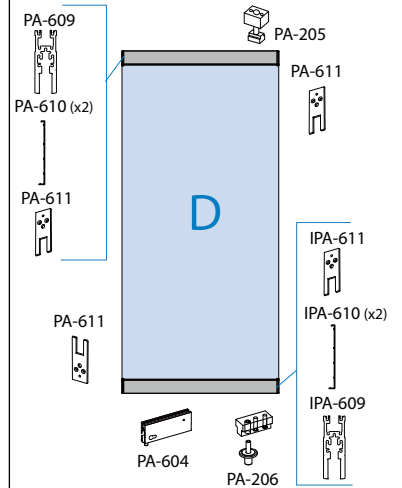





# PA-630 FORTI SPESSORI

SCORREVOLI A PARCHEGGIO / SLIDING STACKING SYSTEMS / GANZGLAS-SCHIEBEWANDSYSTEME

€▶ C.107

€▶ C.108

- Sistema scorrevole a parcheggio con profili fermavetro su misura richiesta dal cliente, senza fori nel vetro e con possibilità di porta centrale a battente e parcheggiabile.
- Sliding stacking system with glass fixing profiles made to measure upon client's request, no need to make holes in the glass and with the possibility of hinged and parkable center panel.
- Schiebesystem mit Parkraum, mit kundenspezifischen Glasleistenprofile mit zentraler Drehtür und Parkmöglichkeit.

SCORREVOLI A PARCHEGGIO  
SLIDING STACKING SYSTEMS

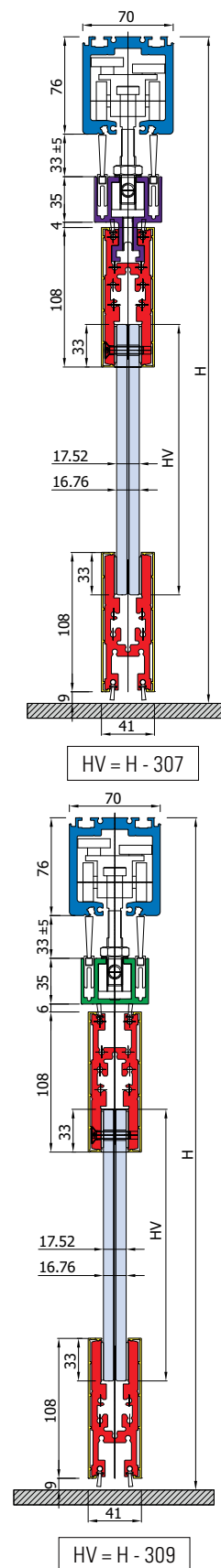

- Porta centrale scorrevole
- Center sliding pivoted door
- Dreh/pendel Schiebepfügel

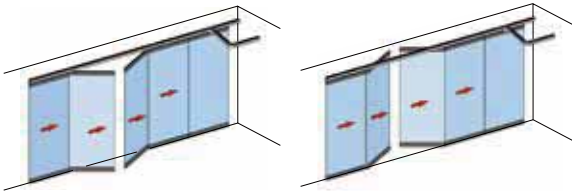

 16,76 17,52	 150 Kg	 110 Kg	 3500 550 min 1000 max
--------------------	------------	------------	---------------------------------

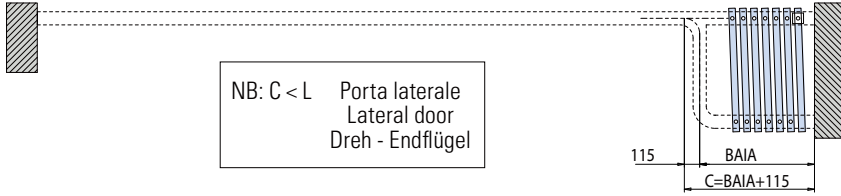

NB: C < L  
Porta laterale  
Lateral door  
Dreh - Endflügel

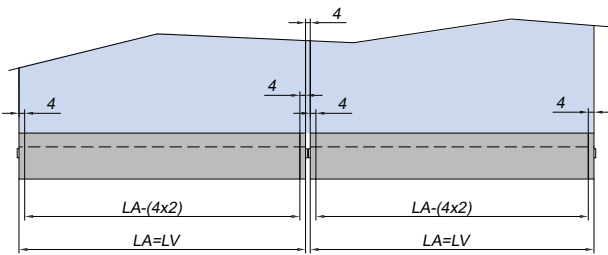
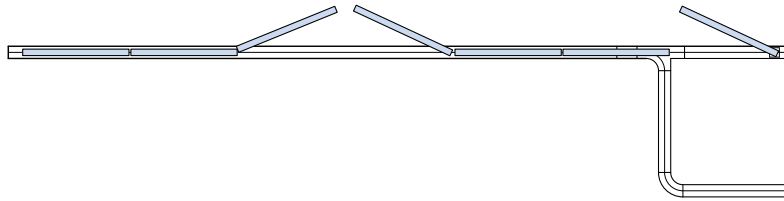

SCORREVOLI A PARCHEGGIO  
SLIDING STACKING SYSTEMS

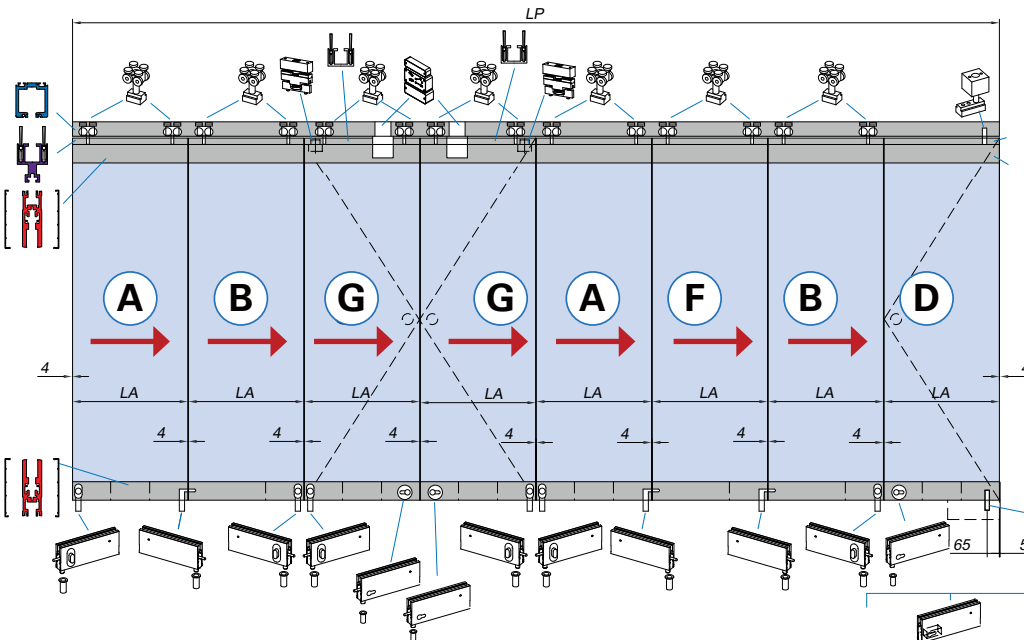

- Calcolo vetro
- Calculation glass
- Glasberechnung

$At = 4 \times (N + 1)$   
 $X = LP - At$   
 $LA = LV \times X / N$

- A**
  - Prima anta
  - First panel
  - Erster Schiebeflügel
- G**
  - Porta centrale scorrevole dx/sx
  - Center sliding pivoted door dx/sx
  - Dreh/Pendel-Schiebeflügel dx/sx
- B**
  - Ultima anta
  - Last panel
  - End-Schiebeflügel
- F**
  - Anta intermedia
  - Intermediate panel
  - Zwischen-Schiebeflügel
- D**
  - Porta laterale
  - Lateral pivot door
  - Dreh-Schiebeflügel

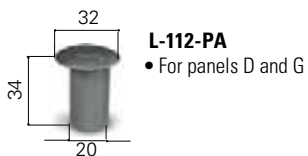

xme527a / xme527f

AN	At	N	LP	LA = LV	H	HV	HA
Alluminio anodizzato Aluminium anodized Aluminium Silberfarbig	Arie totali Total clearances Summe alle Abstände Glas/Wand	Numero ante Numbers panels Anzahl der Elemente	Passaggio luce Clear opening width Lichte Durchgangsbreite	Larghezza ante = Larghezza vetro Panel width = Glass width Flügelbreite = Glasbreite	Altezza passaggio luce Clear opening height Lichte durchgangshöhe	Altezza vetro Glass height Glashöhe	Altezza anta Door height Tür Höhe

**PA-633**

- Scambio per convertire l'anta porta battente del PA-630 in anta scorrevole tramite l'apposita chiave snodata
- Mechanism to convert the center pivoted door of PA-630 in sliding door parkable through the appropriate tool
- System um die zentrale Dreh-Tür des PA-630 in Schiebetür durch das entsprechende Werkzeug umzuwandeln

**PA-308**

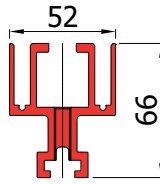

**PA-309**

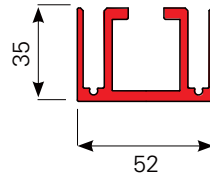

**PA-310**



**PA-311**

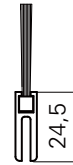

**PA-214**

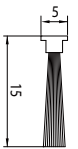

**PA-633**

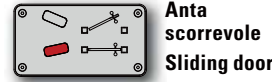
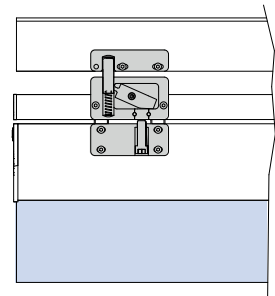
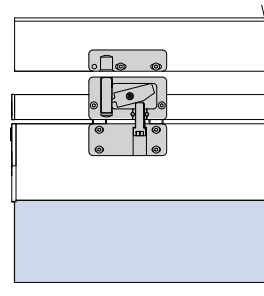
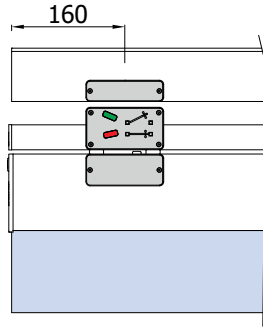
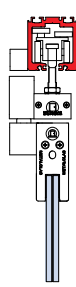
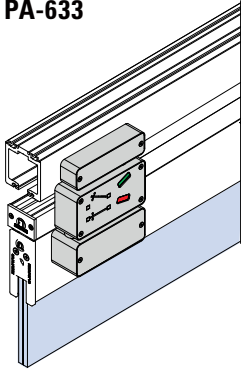

xme527c / xme527e

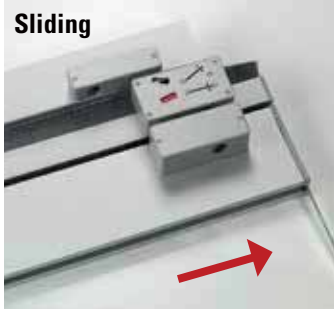



# PA-630 FORTI SPESSORI

**COME USARE MY METALGLAS / HOW TO USE MY METALGLAS / WIE MAN BENUTZT MY METALGLAS**

**1** INSERIRE LE MISURE DEL TUO VANO E LE ANTE DESIDERATE  
ENTER THE MEASUREMENTS OF YOUR OPENING AND THE DOORS YOU REQUIRE  
GEBEN SIE DIE MASSE IHRER ÖFFNUNG EIN UND DIE ERFORDERLICHEN TÜREN

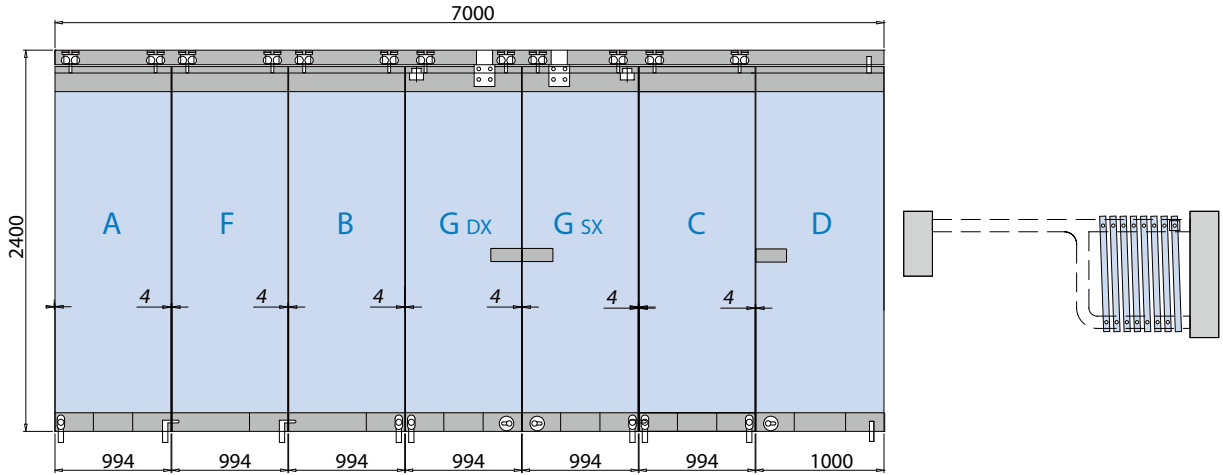

SCORREVOLI A PARCHEGGIO  
SLIDING STACKING SYSTEMS

**2** SI OTTENGONO LE MISURE DEI VETRI AUTOMATICAMENTE  
THE MEASUREMENTS OF THE GLASS WILL BE GENERATED AUTOMATICALLY  
DIE ABMESSUNGEN DES GLASES WERDEN AUTOMATISCH BERECHNET

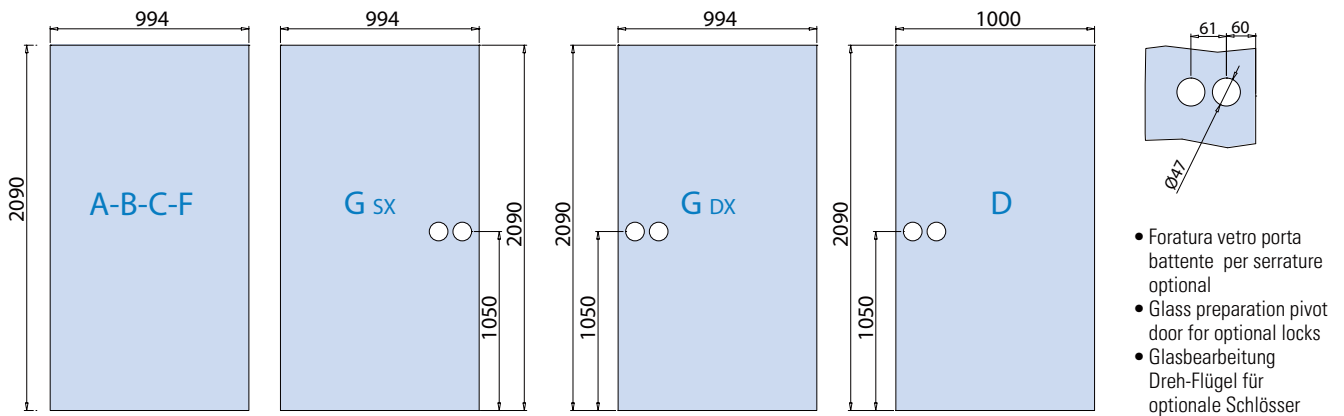

**3** SI OTTENGONO LE DISTINTE DI TAGLIO DEI PROFILI, DA ABBINARE AGLI ACCESSORI  
THE CUTTING SPECIFICATIONS OF THE PROFILES ARE OBTAINED, FOR MATCHING WITH THE ACCESSORIES  
SIE ERHALTEN EINE SPEZIFIKATION DER PROFILLÄNGEN ZUM ABGLEICHEN MIT DEM ZUBEHÖR

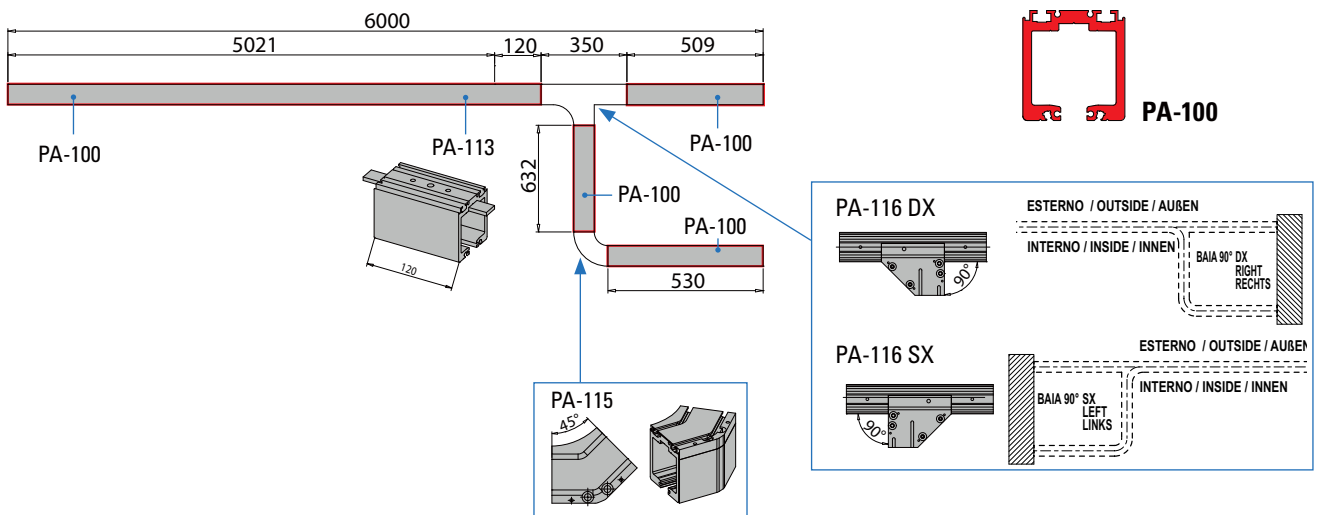

# PA-630 FORTI SPESSORI

## COME ASSEMBLARE LE ANTE / HOW TO ASSEMBLE THE DOORS / WIE DIE TÜREN ZUSAMMENSETZT WERDEN

TAGLIO PROFILI  
PROFIL PREPARATION / PROFILBEARBEITUNG



KIT ACCESSORI  
ACCESSORY SETS / ZUBEHÖR SETS



ANTA COMPLETA  
COMPLETE DOOR / KOMPLETTE TÜR

ANTA A / DOOR A / TÜRA

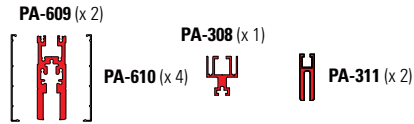

SUPERIORE / TOP / OBEN

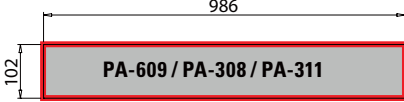

INFERIORE / BOTTOM / UNTEN

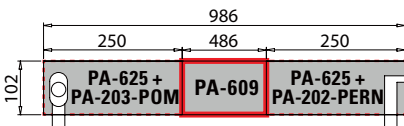

- Lavorazione veletta PA-610 con PA-625 + PA-203-POM
- Cover profile preparation PA-610 with PA-625 + PA-203-POM
- Vorbereitung der Abdeckung PA-610 mit PA-625 + PA-203-POM

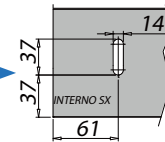

PA-630 ANTA A-16 (for glass 16,76 mm)  
PA-630 ANTA A-17 (for glass 17,52 mm)  
PRIMA ANTA A  
FIRST PANEL A / ERSTER SCHIEBEFLÜGEL A

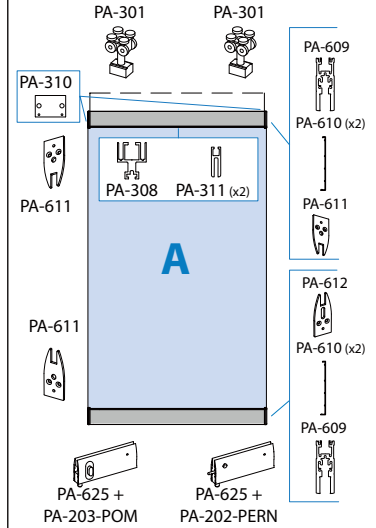
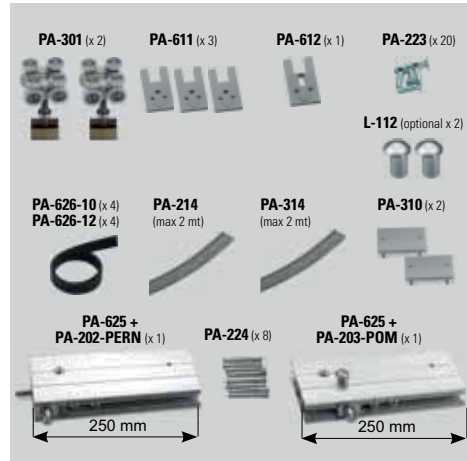

SCORREVOLI A PARCHEGGIO  
SLIDING STACKING SYSTEMS

ANTA B / DOOR B / TÜRB

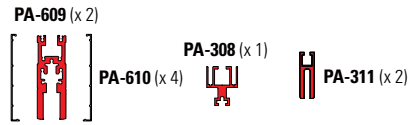

SUPERIORE / TOP / OBEN

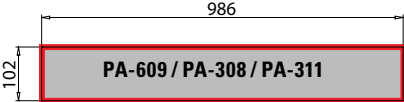

INFERIORE / BOTTOM / UNTEN

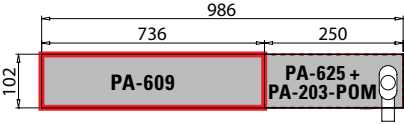

- Lavorazione veletta PA-610 con PA-625 + PA-203-POM
- Cover profile preparation PA-610 with PA-625 + PA-203-POM
- Vorbereitung der Abdeckung PA-610 mit PA-625 + PA-203-POM

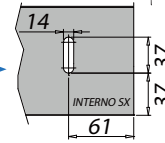

PA-630 ANTA B-16 (for glass 16,76 mm)  
PA-630 ANTA B-17 (for glass 17,52 mm)  
ULTIMA ANTA B  
LAST PANEL B / END-SCHIEBEFLÜGEL B

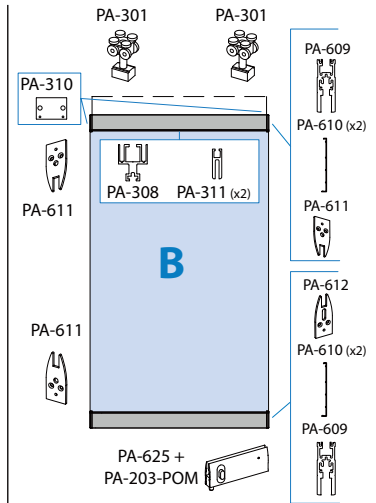

ANTA F / DOOR F / TÜRF

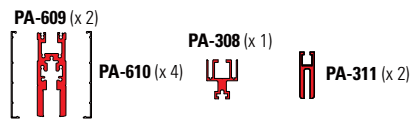

SUPERIORE / TOP / OBEN

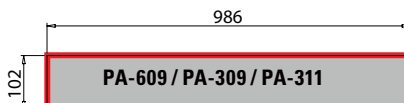

INFERIORE / BOTTOM / UNTEN

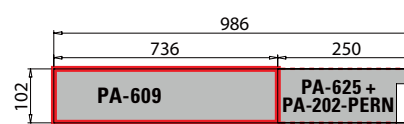

PA-630 ANTA F-16 (for glass 16,76 mm)  
PA-630 ANTA F-17 (for glass 17,52 mm)  
ANTA INTERMEDIA F  
INTERMEDIATE PANEL F / ZWISCHEN-SCHIEBEFLÜGEL F

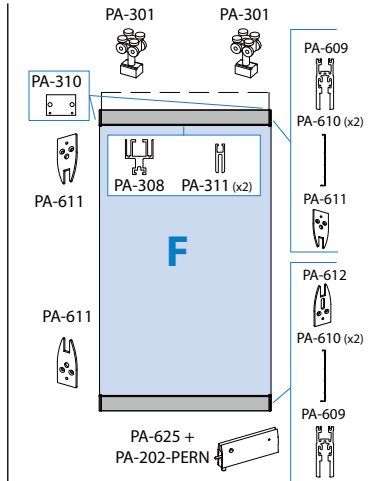
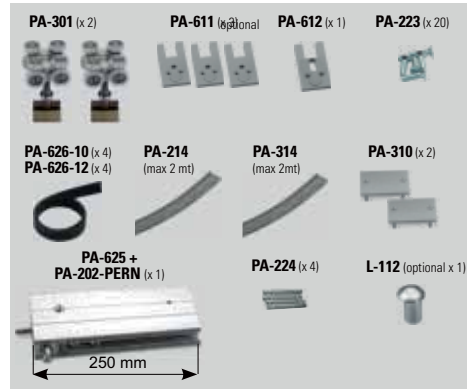

# PA-630 FORTI SPESSORI

## COME ASSEMBLARE LE ANTE / HOW TO ASSEMBLE THE DOORS / WIE DIE TÜREN ZUSAMMENSETZT WERDEN

TAGLIO PROFILI  
PROFIL PREPARATION / PROFILBEARBEITUNG



KIT ACCESSORI  
ACCESSORY SETS / ZUBEHÖR SETS



ANTA COMPLETA  
COMPLETE DOOR / KOMPLETTE TÜR

SCORREVOLI A PARCHEGGIO  
SLIDING STACKING SYSTEMS

ANTA G / DOOR G / TÜR G

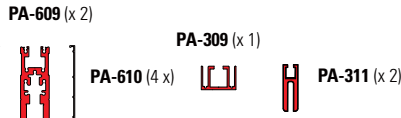

SUPERIORE / TOP / OBEN

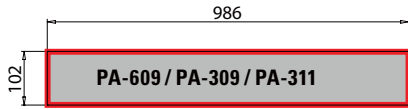

INFERIORE / BOTTOM / UNTEN

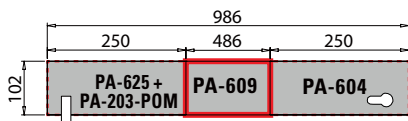

- Lavorazione veletta PA-610 con PA-604 e PA-625 + PA-203-POM
- Cover profile preparation PA-610 with PA-604 and PA-625 + PA-203-POM
- Vorbereitung der Abdeckung PA-610 mit PA-604 und PA-625 + PA-203-POM

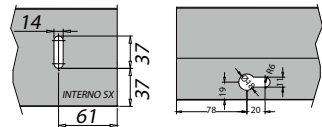

PA-630 ANTA G-16 (for glass 16,76 mm)  
PA-630 ANTA G-17 (for glass 17,52 mm)  
PORTA CENTRALE SCORREVOLE G  
CENTER SLIDING PIVOTED DOOR G  
DREH/PENDEL SCHIEBEFLÜGEL G

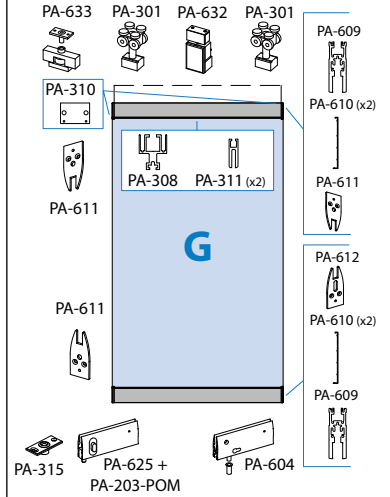
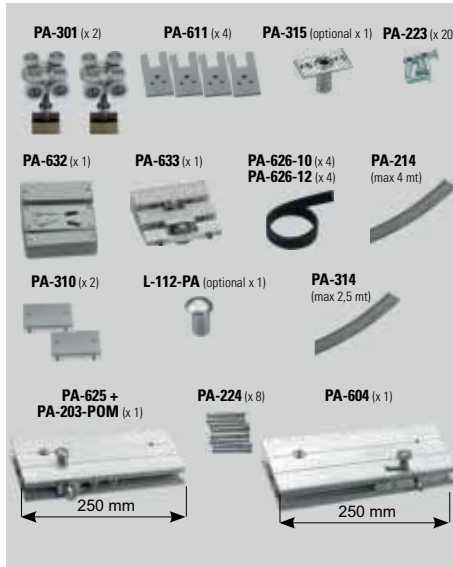

- Lavorazione profili PA-609 / PA-610
- Profiles preparation PA-609 / PA-610
- Vorbereitung der Profile PA-609 / PA-610

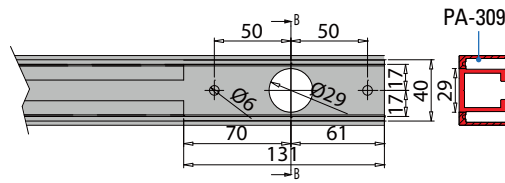
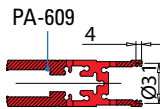
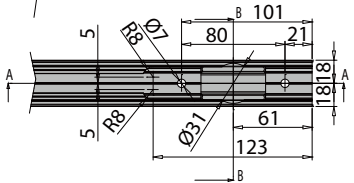
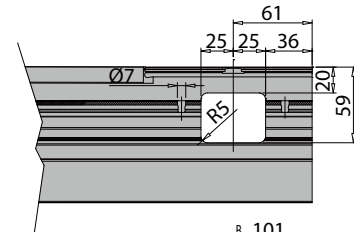

ANTA C / DOOR C / TÜR C

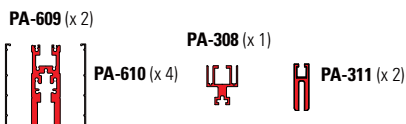

SUPERIORE / TOP / OBEN

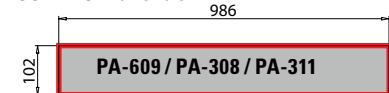

INFERIORE / BOTTOM / UNTEN

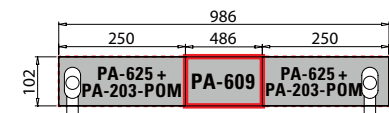

- Lavorazione veletta PA-610 con PA-625 + PA-203-POM
- Cover profile preparation PA-610 with PA-625 + PA-203-POM
- Vorbereitung der Abdeckung PA-610 mit PA-625 + PA-203-POM

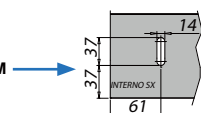

PA-630 ANTA C-16 (for glass 16,76 mm)  
PA-630 ANTA C-17 (for glass 17,52 mm)  
ANTA INTERMEDIA 2 C  
INTERMEDIATE PANEL 2 C  
ZWISCHEN-SCHIEBEFLÜGEL 2 C

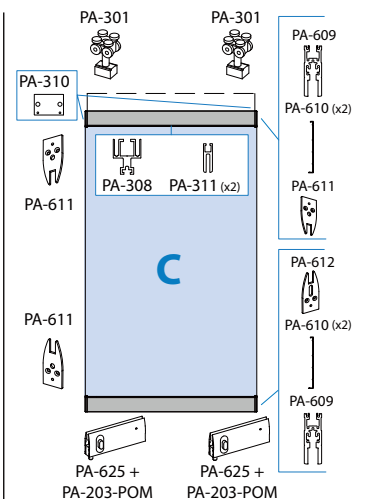
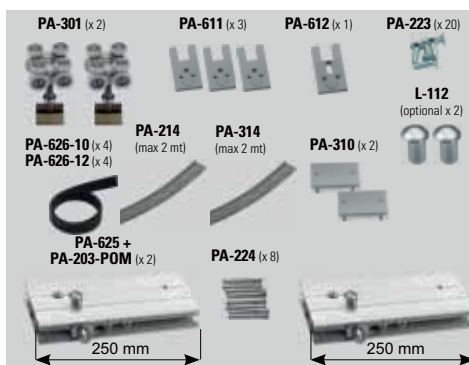



# PA-630 FORTI SPESSORI

## COME ASSEMBLARE LE ANTE / HOW TO ASSEMBLE THE DOORS / WIE DIE TÜREN ZUSAMMENSETZT WERDEN

TAGLIO PROFILI  
PROFIL PREPARATION / PROFILBEARBEITUNG



KIT ACCESSORI  
ACCESSORY SETS / ZUBEHÖR SETS



ANTA COMPLETA  
COMPLETE DOOR / KOMPLETTE TÜR

ANTA D / DOOR D / TÜRD

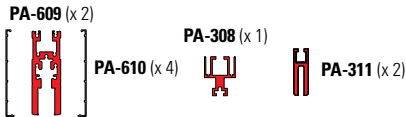

SUPERIORE / TOP / OBEN

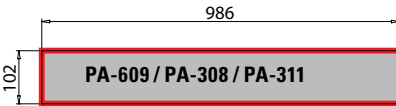

INFERIORE / BOTTOM / UNTEN

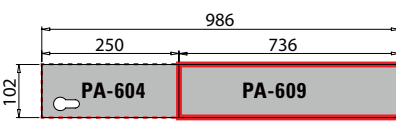

- Lavorazione veletta PA-610 con PA-604
- Cover profile preparation PA-610 with PA-604
- Vorbereitung der Abdeckung PA-610 mit PA-604

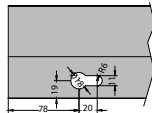

PA-630 ANTA D-16 (for glass 16,76 mm)  
PA-630 ANTA D-17 (for glass 17,52 mm)  
PORTA LATERALE D  
LATERAL PIVOT DOOR D  
DREH-SCHIEBEFLÜGEL D

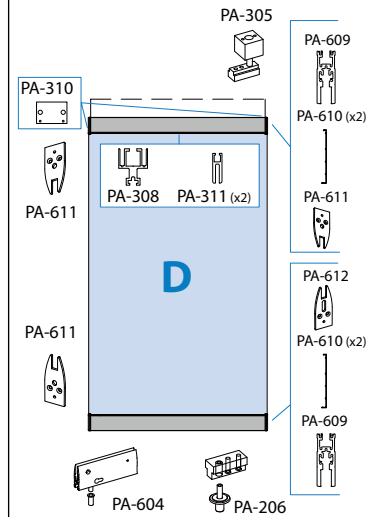

SCORREVOLI A PARCHEGGIO  
SLIDING STACKING SYSTEMS





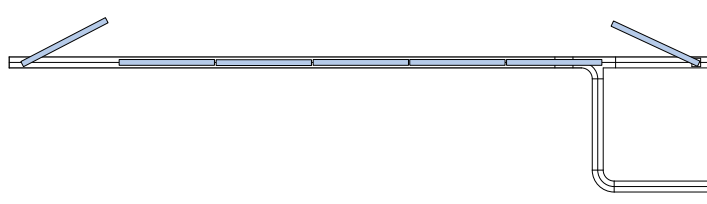
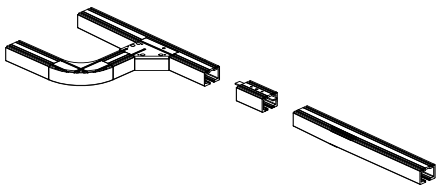
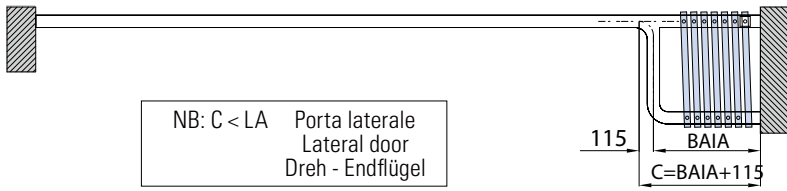
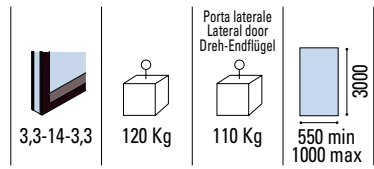
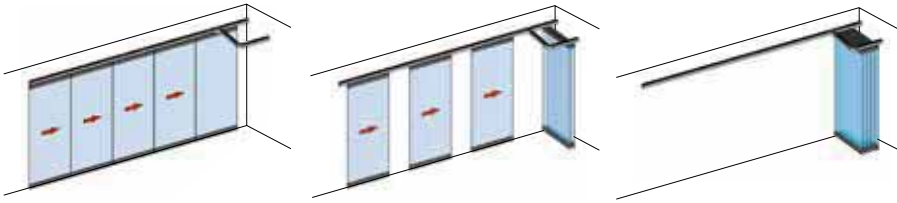

**PA-108**

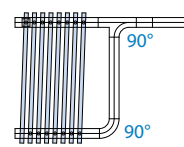

**PA-109**

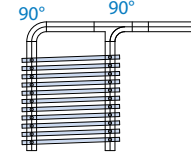

**PA-113**

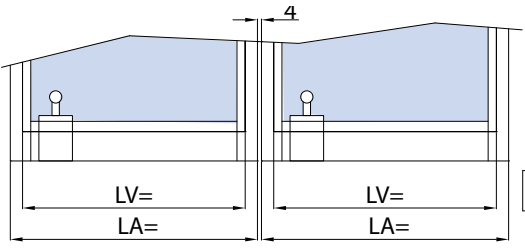
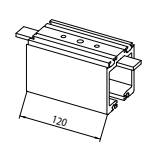

- Baie da ordinare a parte oltre alle ante, altre baie disponibili da pag. 66
- To be ordered separately from the panels, other parking bays available from page 66
- Neben den Flügel extra zu bestellen, andere Parkräume auf Seite 66

**L-112-PA**

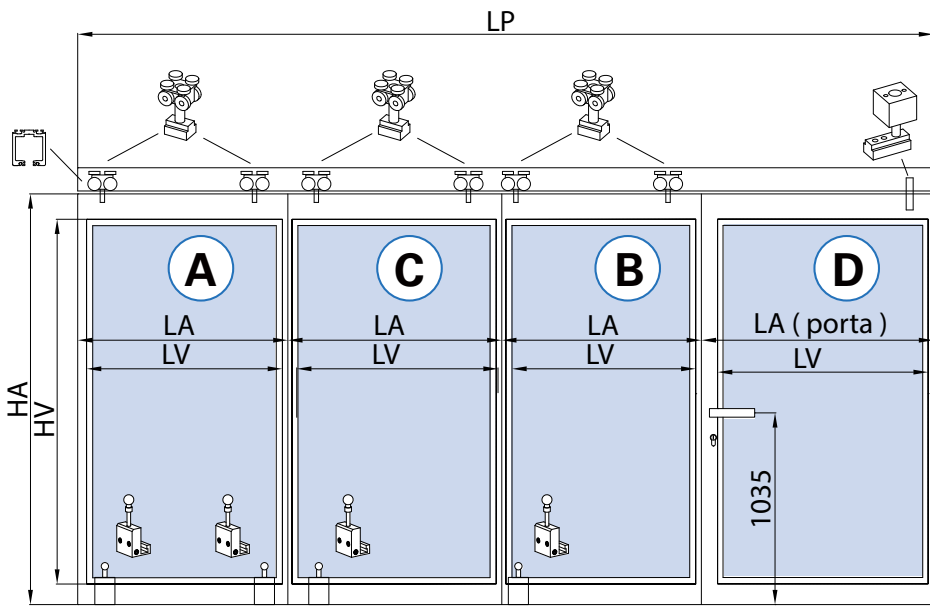

- A**
  - Prima anta scorrevole
  - First sliding panel
  - Erster Schiebeflügel
- B**
  - Ultima anta scorrevole
  - Last sliding panel
  - Letzter Schiebeflügel
- C**
  - Anta scorrevole
  - Sliding panel
  - Schiebeflügel
- D**
  - Porta laterale con serratura
  - Lateral pivot door with lock
  - Dreh-Flügel mit Schloss



xfb-134

AN	At	N	LP	LA = LV	H	HV	HA
Alluminio anodizzato	Arie totali	Numero ante	Passaggio luce	Larghezza ante = Larghezza vetro	Altezza passaggio luce	Altezza vetro	Altezza anta
Aluminium anodized	Total clearances	Numbers panels	Clear opening width	Panel width = Glass width	Clear opening height	Glass height	Door height
Aluminium Silberfarbig	Summe alle Abstände	Anzahl der Elemente	Lichte Durchgangsbreite	Flügelbreite = Glasbreite	Lichte durchgangshöhe	Glashöhe	Tür Höhe

# BAIA DI PARCHEGGIO / STACKING ARRANGEMENTS / PARKSITUATIONEN

## ESEMPI / EXAMPLES / BEISPIELE

SCORREVOLI A PARCHEGGIO  
SLIDING STACKING SYSTEMS

**A1** PA-108 DX  
PA-108 SX

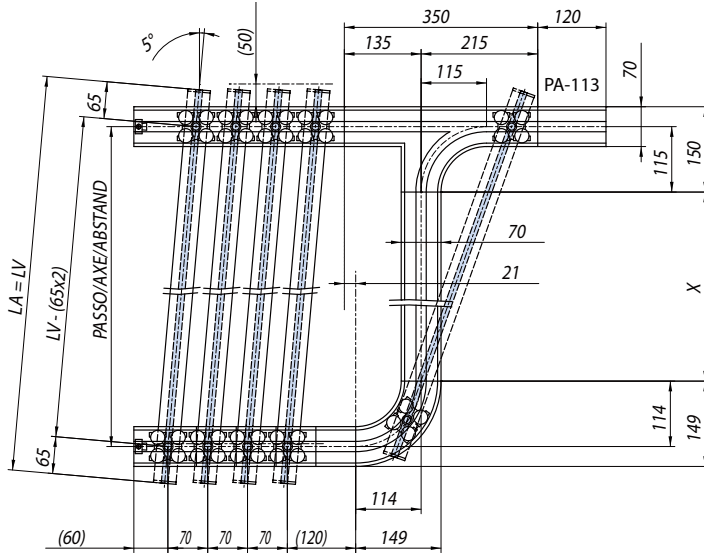

- Vista dall'alto (da sopra il profilo guida)
- View from above the rail
- Sicht von oben über der Laufschiene

€ C.145

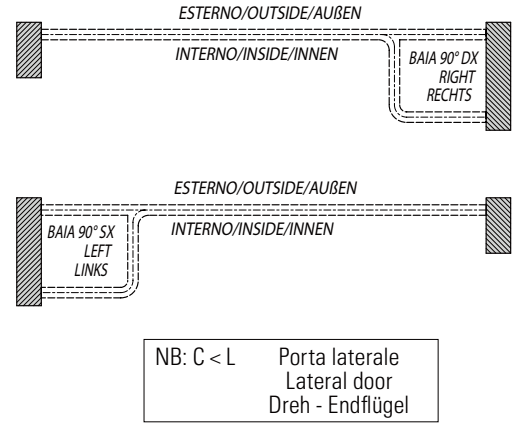

NB: C < L Porta laterale  
Lateral door  
Dreh - Endflügel

xla167\_0

**A2** PA-109 DX  
PA-109 SX

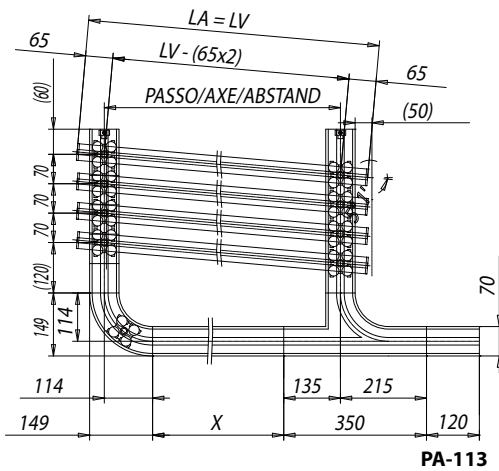

- Vista dall'alto (da sopra il profilo guida)
- View from above the rail
- Sicht von oben über der Laufschiene

€ C.146

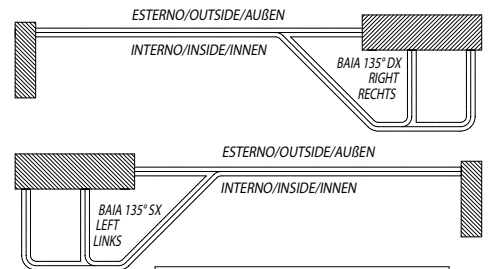

$$\text{Passo} = [LV - (65 \times 2)] \times 0.996$$

$$X = \text{Passo} - 135 - 114$$

NB: C < L Porta laterale  
Lateral door  
Dreh - Endflügel

xla167\_1

**D** PA-119-D DX  
PA-119-D SX

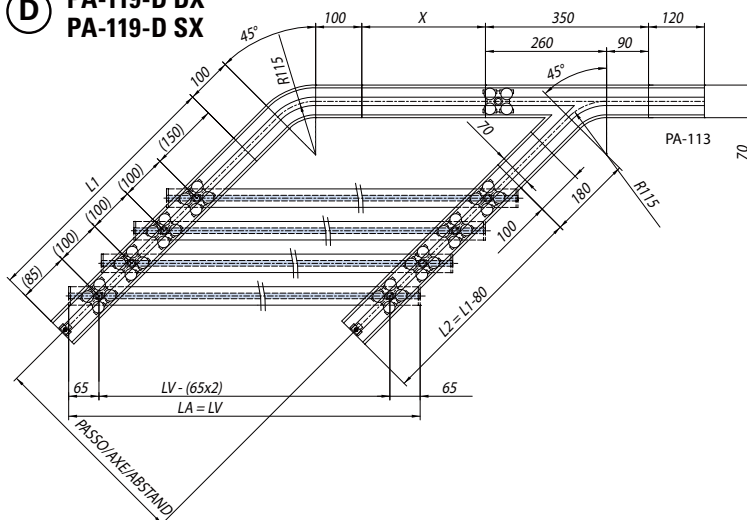

- Vista dall'alto (da sopra il profilo guida)
- View from above the rail
- Sicht von oben über der Laufschiene

€ C.149

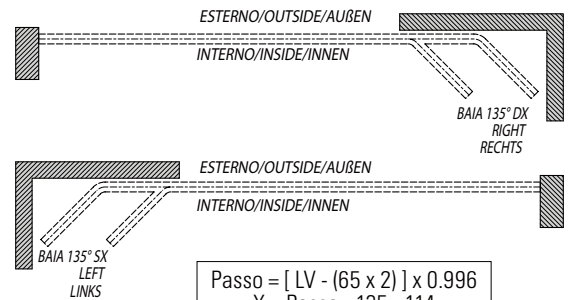

$$\text{Passo} = [LV - (65 \times 2)] \times 0.996$$

$$X = \text{Passo} - 135 - 114$$

NB: C < L Porta laterale  
Lateral door  
Dreh - Endflügel

xla167\_0

# BAIA DI PARCHEGGIO / STACKING ARRANGEMENTS / PARKSITUATIONEN

## ESEMPI / EXAMPLES / BEISPIELE

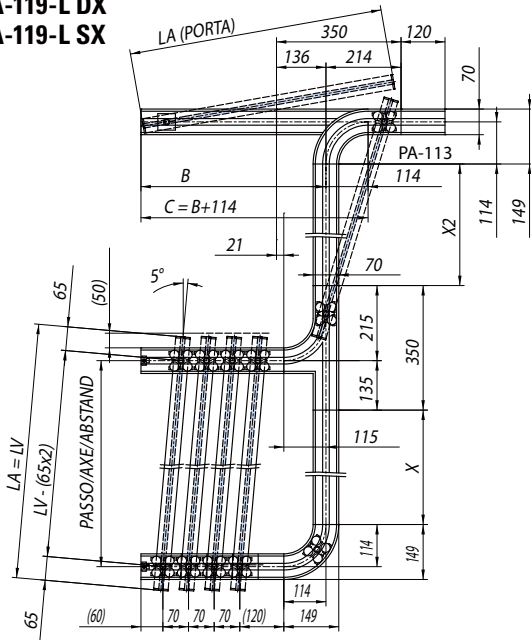
**L PA-119-L DX  
PA-119-L SX**

- Vista dall'alto (da sopra il profilo guida)
- View from above the rail
- Sicht von oben über der Laufschiene

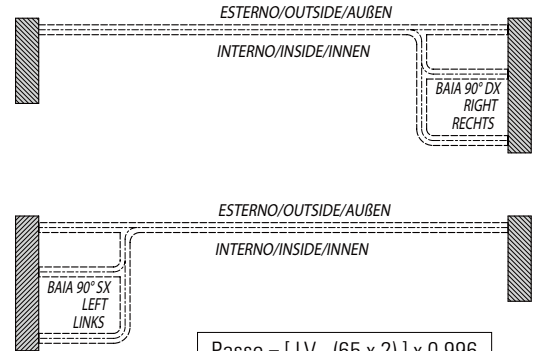

$$\text{Passo} = [LV - (65 \times 2)] \times 0.996$$

$$X = \text{Passo} - 135 - 114$$

NB: C < L Porta laterale  
Lateral door  
Dreh - Endflügel

xla167\_0

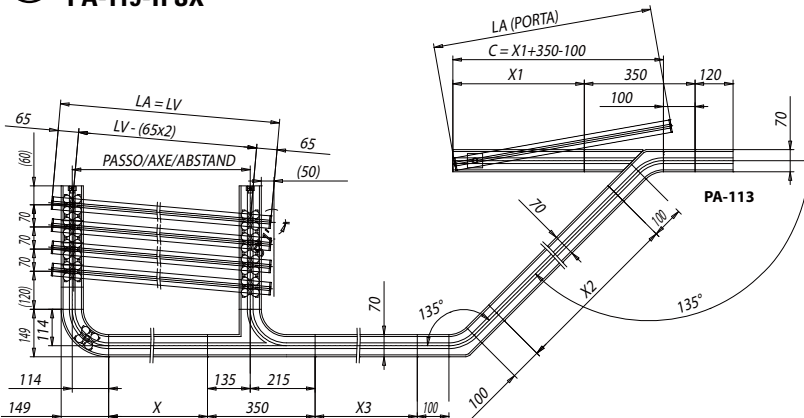
**H PA-119-H DX  
PA-119-H SX**

- Vista dall'alto (da sopra il profilo guida)
- View from above the rail
- Sicht von oben über der Laufschiene

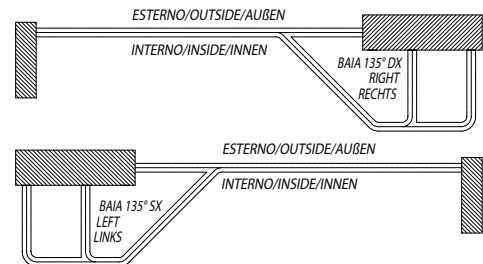

$$\text{Passo} = [LV - (65 \times 2)] \times 0.996$$

$$X = \text{Passo} - 135 - 114$$

NB: C < L Porta laterale  
Lateral door  
Dreh - Endflügel

xla 167\_1

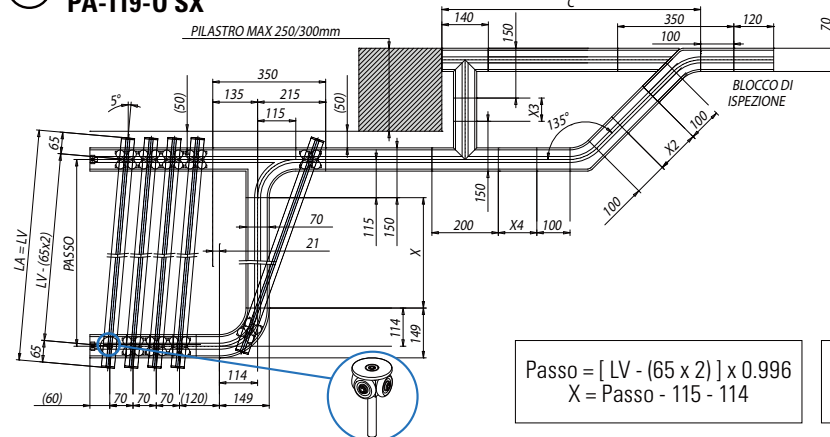
**O PA-119-O DX  
PA-119-O SX**

- Vista dall'alto (da sopra il profilo guida)
- View from above the rail
- Sicht von oben über der Laufschiene

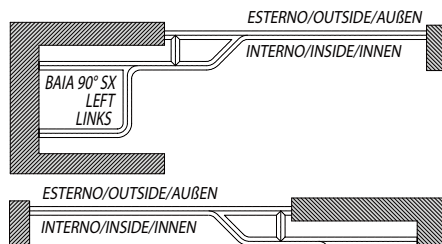

$$\text{Passo} = [LV - (65 \times 2)] \times 0.996$$

$$X = \text{Passo} - 115 - 114$$

NB: C < LA Prima anta  
First panel  
Erster-Schiebeflügel

xla 167\_f

**Passo**  
Interasse carrelli  
Axe  
Abstand

**LA = LV**  
Larghezza ante = Larghezza vetro  
Panel width = Glass width  
Flügelbreite = Glasbreite

# BAIA DI PARCHEGGIO / STACKING ARRANGEMENTS / PARKSITUATIONEN

## ESEMPI / EXAMPLES / BEISPIELE

SCORREVOLI A PARCHEGGIO  
SLIDING STACKING SYSTEMS

**B** PA-119-B-DX  
PA-119-B-SX

€▶C.147

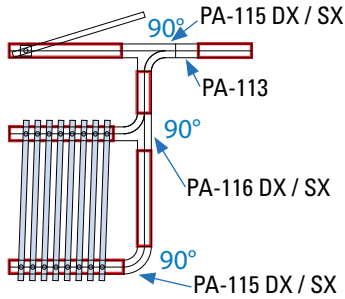

**C** PA-119-C-DX  
PA-119-C-SX

€▶C.148

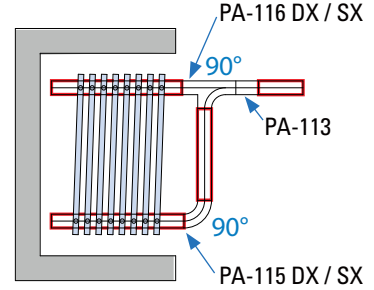

**D** PA-119-D-DX  
PA-119-D-SX

€▶C.149

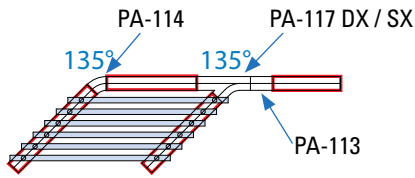

**F** PA-119-F-DX  
PA-119-F-SX

€▶C.150

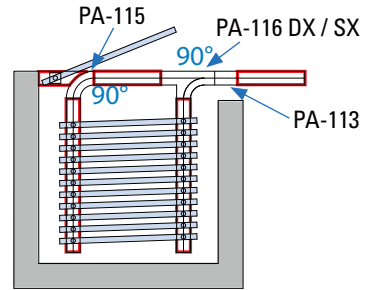

**I** PA-119-I-DX  
PA-119-I-SX

€▶C.153

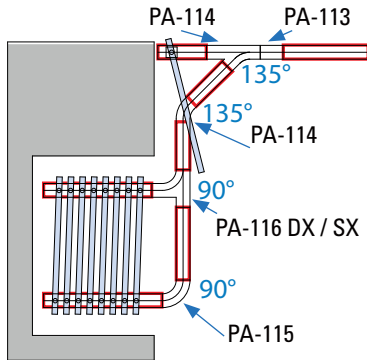

**L** PA-119-L-DX  
PA-119-L-SX

€▶C.154

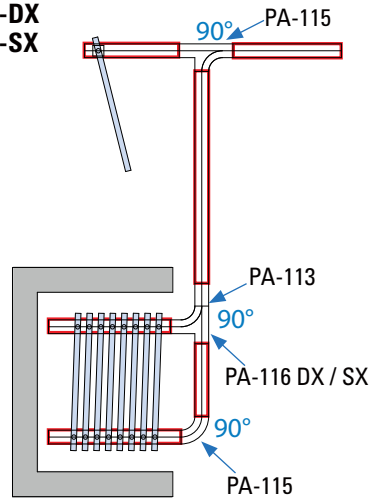

**M** PA-119-M-DX  
PA-119-M-SX

€▶C.155

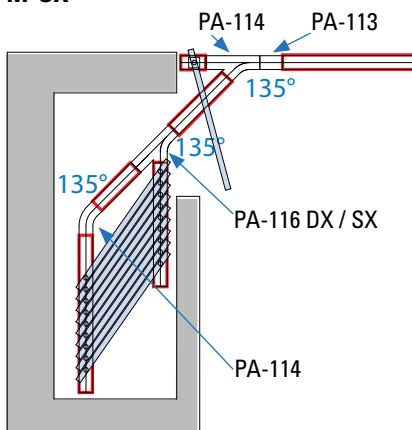

**N** PA-119-N-DX  
PA-119-N-SX

€▶C.156

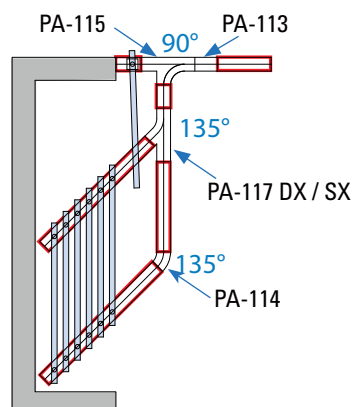

# BAIA DI PARCHEGGIO / STACKING ARRANGEMENTS / PARKSITUATIONEN

## COMPONENTI / COMPONENTS / EINZELTEILE

**G** PA-119-G-DX  
PA-119-G-SX

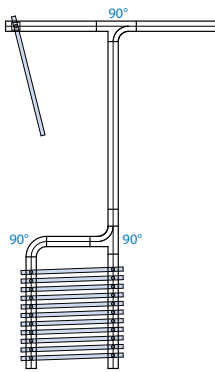

€▶ C.151

**P** PA-119-P-DX  
PA-119-P-SX

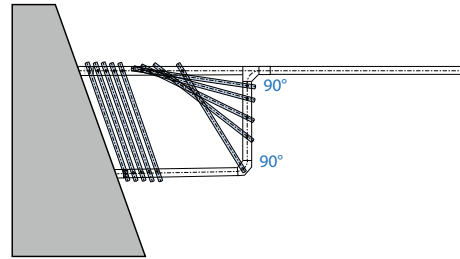

€▶ C.158

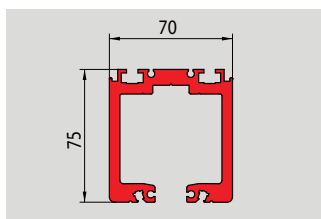

**PA-100**

€▶ C.02

- Binario superiore di scorrimento in alluminio anodizzato
- Anodised aluminium top track profile
- Natureloxierten Aluminium Laufschieneprofil

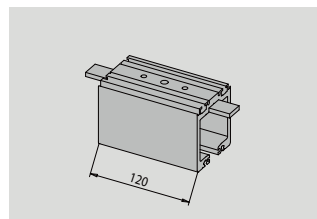

**PA-113**

€▶ C.140

- Pezzo profilo per apertura manutenzione
- Profile piece for maintenance
- Revisionsstück

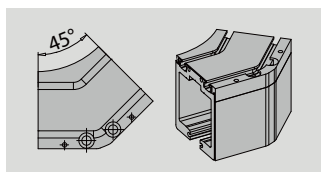

**PA-114**

- Curva 45°
- Curved section 45°
- Modul für 45° Winkel

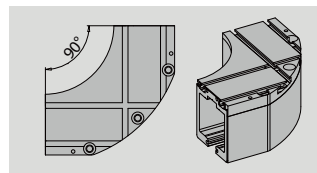

**PA-115**

€▶ C.141

- Curva 90°
- Curved section 90°
- Modul für 90° Winkel

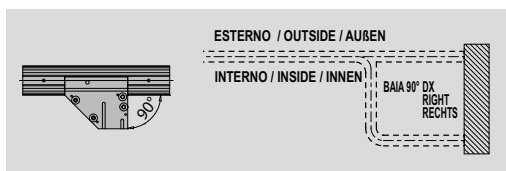

**PA-116 DX**

- Scambio 90° destro
- 90° angle right
- 90° Abzweig rechts

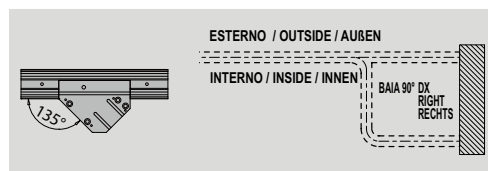

**PA-117 DX**

- Scambio 135° destro
- 135° T-piece right
- T-Stück/Abzweig 135° rechts

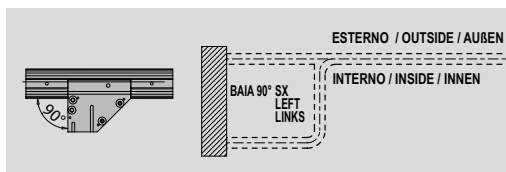

**PA-116 SX**

- Scambio 90° sinistro
- 90° angle left
- 90° Abzweig links

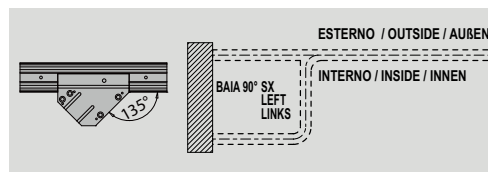

**PA-117 SX**

- Scambio 135° sinistro
- 135° T-piece left
- T-Stück/Abzweig 135° links



# SCORREVOLI A LIBRO

## SLIDING FOLDING SYSTEMS

## FALT-SCHIEBEWANDSYSTEME

Con guida a terra / With bottom guide channel / Mit Bodenführung

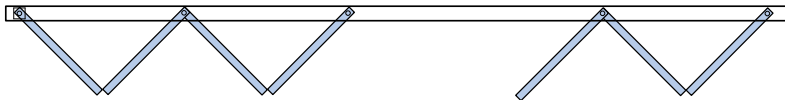

### PA-250 LIBRO FOLDING ▶ 72

### PA-650 ▶ 92

- Sistema scorrevole a parcheggio fornito con profili fermavetro a misure richieste dal cliente, senza necessità di fori nel vetro.
- Sliding folding door system with glass fixing profiles made to measure upon client's request, no need glass preparation.
- Falt-Schiebewandsystem, mit kundenspezifischen Glasleistenprofilen, ohne Glasbohrungen



<b>PA-250</b>
90 Kg
10-12-12,7
3000 550 min 1000 max

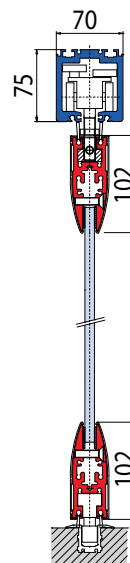

<b>PA-650</b>
90 Kg
16,76-17,52
3500 550 min 1000max

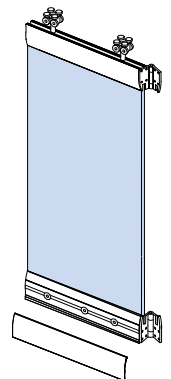
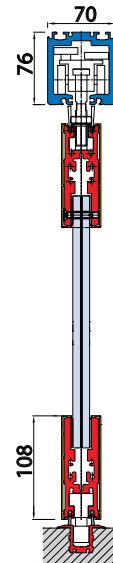

### PA-750 LIBRO FOLDING do-it-yourself ▶ 78

### PA-550 LIBRO FOLDING do-it-yourself ▶ 86

- Sistema scorrevole a libro con profili fermavetro continui a misura standard (mm 1000) da tagliare secondo necessità a cura del cliente, completi di catenaccioli fermaanta a posizionamento esterno regolabile. Vantaggi di una consegna più veloce e di un unico prodotto a magazzino per tutte le misure fino a 850 mm.
- Sliding folding door system with continuous glass fixing profiles of a standard size (mm 1000) to be cut by installer comes equipped with an adjustable door holding latch positioned externally. The advantage of this product is quick delivery and a unique product available in the warehouse for all sizes up to 850 mm.
- Schiebeyesystem mit durchgehenden Glasleistenprofilen in Standardgröße (1000 mm), ablängbar, komplett mit äußeren einstellbaren Riegeln zur Flügelfeststellung. Vorteile einer raschen Lieferung und eines einzigen lagermäßigen Produktes mit Abmessungen bis 850 mm.



<b>PA-750</b>
70 Kg
10-12
3000 800 max

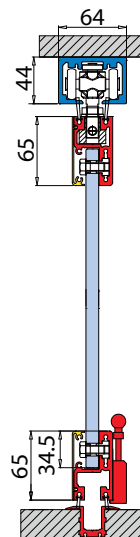

<b>PA-550</b>
70 Kg
10-12-12,7
2800 450 min 850 max

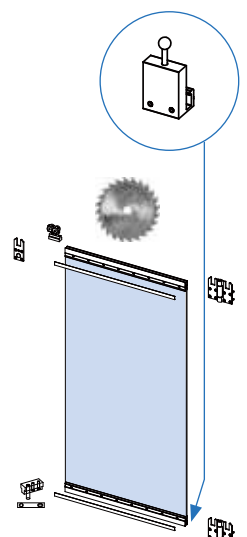
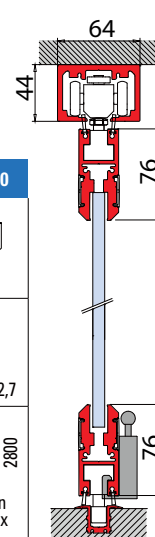



**PA-450 LIBRO FOLDING do-it-yourself ▶ 84**

- Sistema scorrevole modulare a libro con morsetti fermavetro (mm 250) e veletta continua (mm 1200) da tagliare secondo necessità a cura del cliente. Vantaggi di una consegna più veloce e di un unico prodotto a magazzino per tutte le misure fino a 1000 mm.
- Sliding folding door system with glass fixing clamps (mm 250) and continuous covers (mm 1200) to be cut on the basis of client's requirements. The advantage of this product is quick delivery and a unique product available in the warehouse for all sizes up to 1000 mm.
- Modulares Schiebesystem mit Gashalteklammern (250 mm) und kontinuierlicher Verkleidung (1200 mm), kundenspezifisch ablängbar. Vorteile einer raschen Lieferung und eines einzigen lagermäßigen Produktes mit Abmessungen bis 1000 mm.

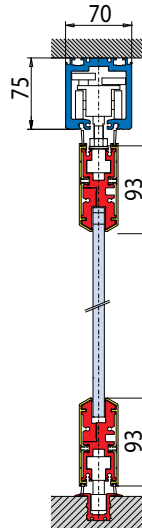
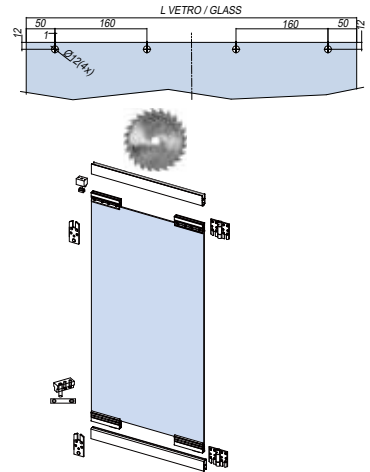

<b>PA-450</b>
90 Kg
10-12-12,7
550 min 1000 max

**LAVORAZIONE VETRO  
GLASS PREPARATION  
GLASBEARBEITUNG**

**L-1500 LIBRO FOLDING ▶ 94**

- Sistema scorrevole a libro con cerniere a vista e fori nel vetro, completo di binario standard h = 44 mm x L = 64 mm e carrello con 4 ruote.
- Sliding folding door system with visible hinges and holes in glass, including standard rail h = 44 mm x L = 64 mm and carriage with 4 wheels.
- Faltschiebewandsystem mit sichtbaren Bändern und Glasbohrungen, komplett mit Standard-Laufschiene h = 44 mm x L = 64 mm und Laufwagen mit 4 Rädern.

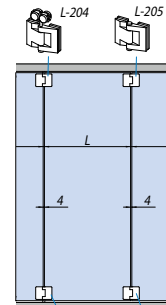
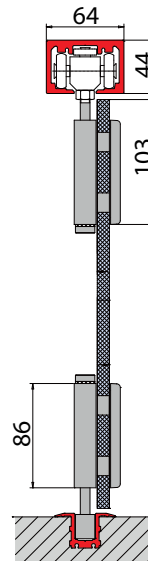

<b>L-1500</b>
70 Kg
8 - 10
450 min 850 max

**L-1000 LIBRO FOLDING ▶ 96**

- Sistema scorrevole a libro con cerniere a vista e fori nel vetro, completo di binario standard h=75 mm x L=70 mm e carrello con 8 ruote.
- Sliding folding door system with visible hinges and holes in glass, including standard rail h=75 mm x L=70 mm and carriage with 8 wheels
- Faltschiebewandsystem mit sichtbaren Bändern und Glasbohrungen, komplett mit Standard-Laufschiene h=75 mm x L=70 mm und Laufwagen mit 8 Rädern.



<b>L-1000</b>
90 Kg
8 - 10
500 min 1000 max

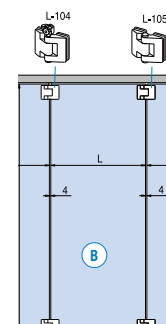
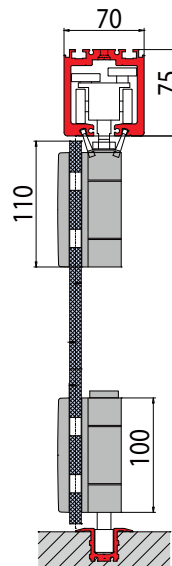

# PA-250 LIBRO FOLDING

SCORREVOLI A LIBRO / SLIDING FOLDING SYSTEMS / FALT-SCHIEBEWANDSYSTEME

**MY METALGLAS**

€ C.159



- Sistema scorrevole a libro fornito con profili fermavetro a misura richiesta dal cliente, senza necessità di fori nel vetro.
- Sliding folding door system with glass fixing profiles made to measure upon client's request, no need to make holes in the glass.
- Falt-Schiebewandssystem, mit kundenspezifischen Glasleistenprofilen, ohne Glasbohrungen.

SCORREVOLI A LIBRO  
SLIDING FOLDING SYSTEMS

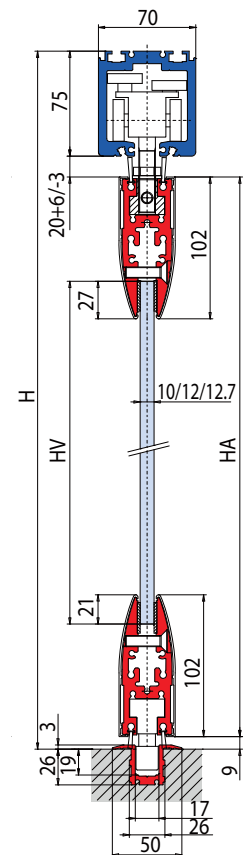

HV = H - 258  
HA = H - 102

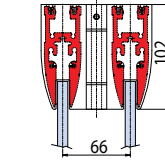
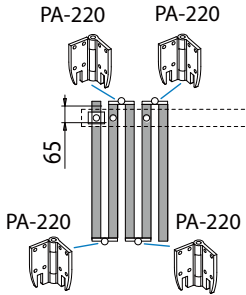
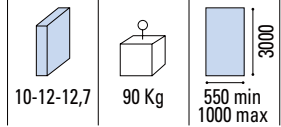
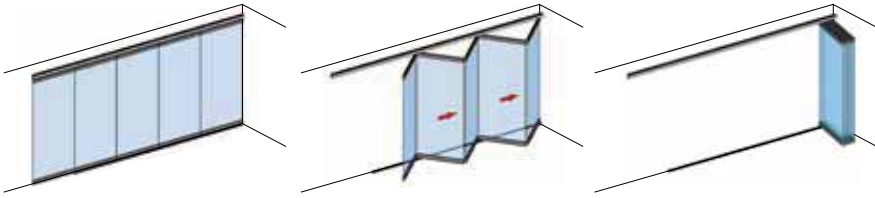

**PA-100**

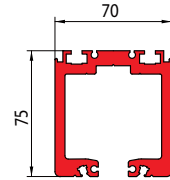

**L-113 standard**

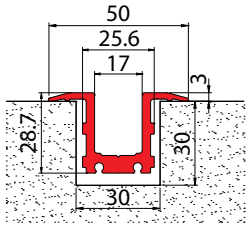

**L-110 optional**

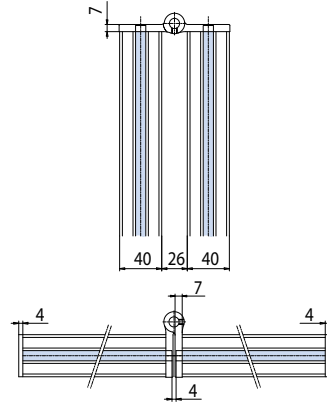
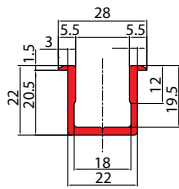

**PA-113**

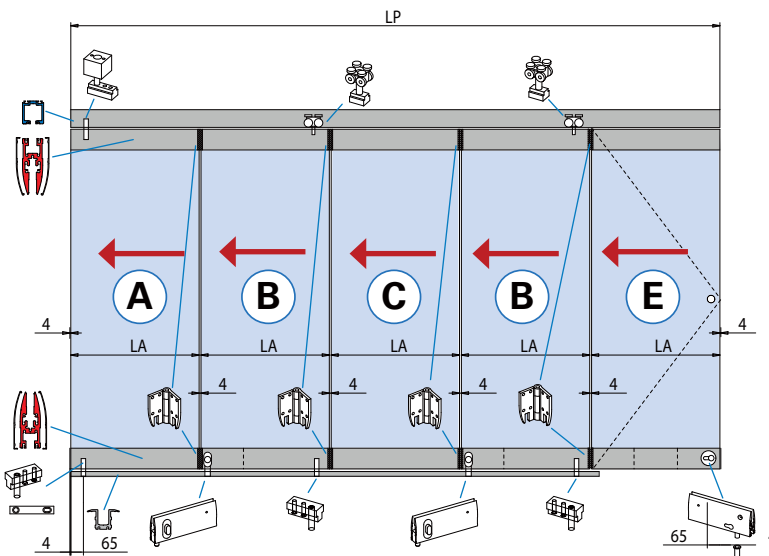
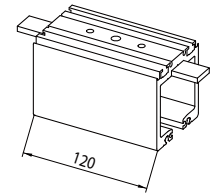

- Calcolo vetro
- Calculation glass
- Glasberechnung

At = 4 x (N + 1)  
X = LP - At  
LA = LV = X / N

	PA-250 SET 2	(A D)
	PA-250 SET 3	(A B E)
	PA-250 SET 4	(A B C D)
	PA-250 SET 5	(A B C B E)
	PA-250 SET 6	(A B C B C D)
	PA-250 SET 7	(A B C B C B E)

- (A)**
  - Prima anta a libro
  - First folding panel
  - Erster Faltelement
- (B C)**
  - Anta intermedia a libro
  - Intermediate folding panel
  - Mittiges Faltelement
- (D)**
  - Ultima anta porta battente con numero ante pari
  - Last hinged door with even no. panels
  - Letzter Dreh-Flügel bei gerader Flügelanzahl
- (E)**
  - Ultima anta con N° ante dispari
  - Last panel with odd no. panels
  - Letzter Flügel bei ungerader Flügelanzahl



xla173 new / xla173 / xla170 / xme295

AN	At	N	LP	LA = LV	H	HV	HA
Alluminio anodizzato	Arie totali	Numero ante	Passaggio luce	Larghezza ante = Larghezza vetro	Altezza passaggio luce	Altezza vetro	Altezza anta
Aluminium anodized	Total clearances	Numbers panels	Clear opening width	Panel width = Glass width	Clear opening height	Clear height	Door height
Aluminium Silberfarbig	Summe alle Abstände Glas/Wand	Anzahl der Elemente	Lichte Durchgangsbreite	Flügelbreite = Glasbreite	Lichte durchgangshöhe	Glashöhe	Tür Höhe

# PA-250 LIBRO FOLDING

**COME USARE MY METALGLAS / HOW TO USE MY METALGLAS / WIE MAN BENUTZT MY METALGLAS**

**1** INSERIRE LE MISURE DEL TUO VANO E LE ANTE DESIDERATE  
ENTER THE MEASUREMENTS OF YOUR OPENING AND THE DOORS YOU REQUIRE  
GEBEN SIE DIE MASSE IHRER ÖFFNUNG EIN UND DIE ERFORDERLICHEN TÜREN

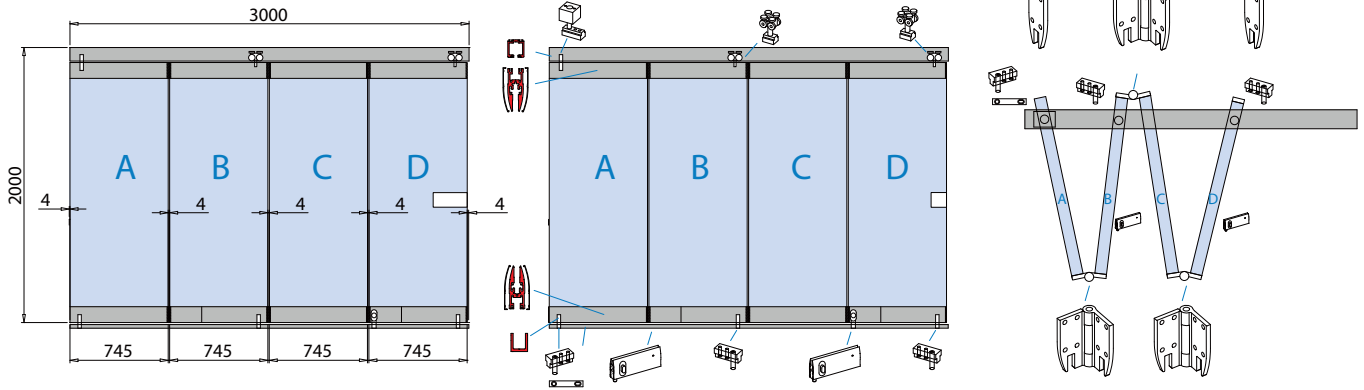

**2** SI OTTENGONO LE MISURE DEI VETRI AUTOMATICAMENTE  
THE MEASUREMENTS OF THE GLASS WILL BE GENERATED AUTOMATICALLY  
DIE ABMESSUNGEN DES GLASES WERDEN AUTOMATISCH BERECHNET

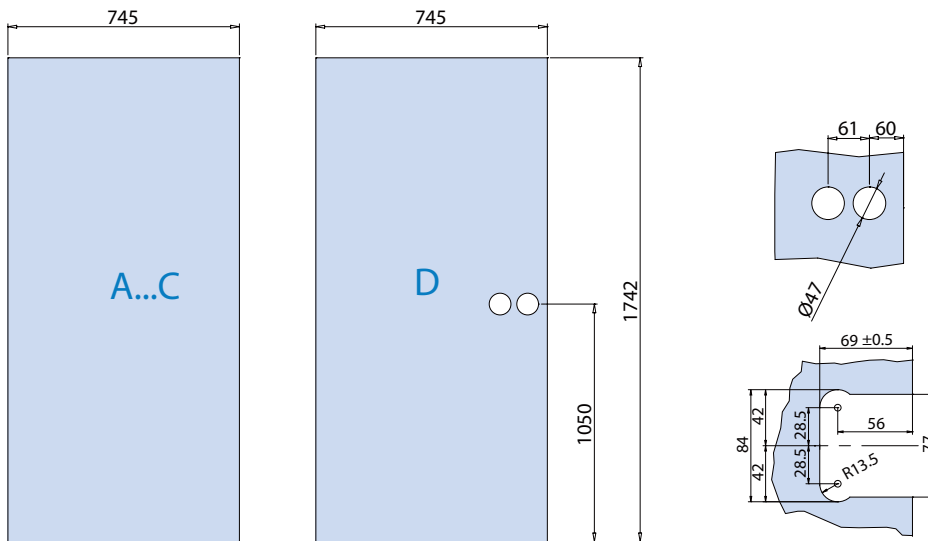

- Foratura vetro porta battente per serrature optional
- Glass preparation pivot door for optional locks
- Glasbearbeitung Dreh-Flügel für optionale Schlösser

- Foratura vetro porta battente per serrature optional V-504, V-505, V-518, V-519, V-520
- Glass preparation pivot door for optional locks V-504, V-505, V-518, V-519, V-520
- Glasbearbeitung Dreh-Flügel für optionale Schlösser V-504, V-505, V-518, V-519, V-520

**3** SI OTTENGONO LE DISTINTE DI TAGLIO DEI PROFILI, DA ABBINARE AGLI ACCESSORI  
THE CUTTING SPECIFICATIONS OF THE PROFILES ARE OBTAINED, FOR MATCHING WITH THE ACCESSORIES  
SIE ERHALTEN EINE SPEZIFIKATION DER PROFILLÄNGEN ZUM ABGLEICHEN MIT DEM ZUBEHÖR

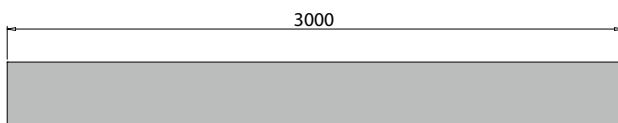

**PA-100**

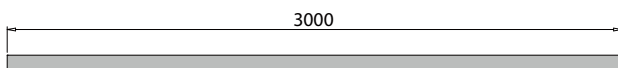
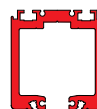

**L-113**

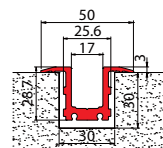

# PA-250 LIBRO FOLDING

## COME ASSEMBLARE LE ANTE / HOW TO ASSEMBLE THE DOORS / WIE DIE TÜREN ZUSAMMENSETZT WERDEN

TAGLIO PROFILI PROFIL PREPARATION / PROFILBEARBEITUNG	KIT ACCESSORI ACCESSORY SETS / ZUBEHÖR SETS	ANTA COMPLETA COMPLETE DOOR / KOMPLETTE TÜR
--	--	--

**ANTA A / DOOR A / TÜRA**

PA-209 (x 2)  
PA-210 (x 4)

**SUPERIORE / TOP / OBEN**  
734  
102  
PA-209

**INFERIORE / BOTTOM / UNTEN**  
734  
102  
PA-209

**PA-250 ANTA A-10** (for glass 10 mm)  
**PA-250 ANTA A-12** (for glass 12 - 12,7 mm)  
 PRIMA ANTA A LIBRO A  
 FIRST FOLDING PANEL A  
 ERSTES FALTELEMENT A

PA-205 (x 1) PA-220 (x 2) PA-211 (x 2)  
 PA-222 (x 1) PA-223 (x 16)  
 PA-225-10 (x 1) PA-225-12 (x 1) L-112 (optional x 1)

**ANTA B / DOOR B / TÜRB**

PA-209 (x 2)  
PA-210 (x 4)

**SUPERIORE / TOP / OBEN**  
731  
102  
PA-209

**INFERIORE / BOTTOM / UNTEN**  
731  
250 481  
102  
PA-225 + PA-203 - POM PA-209

• Lavorazione vettura PA-209 con PA-225 + PA-203-POM  
 • Cover profile preparation PA-209 with PA-225 + PA-203-POM  
 • Vorbereitung der Abdeckung PA-209 mit PA-225 + PA-203-POM

**PA-250 ANTA B-10** (for glass 10 mm)  
**PA-250 ANTA B-12** (for glass 12 - 12,7 mm)  
 ANTA INTERMEDIA A LIBRO B  
 MIDDLE FOLDING PANEL B  
 MITTIGES FALTELEMENT B

PA-201 (x 1) PA-220 (x 2) PA-221 (x 1)  
 PA-223 (x 16) PA-225-10 (x 1) PA-225-12 (x 1) PA-214 (x 1)  
 PA-225 + PA-203-POM (x 1) PA-224 (x 4) L-112 (optional x 1)

**ANTA C / DOOR C / TÜRC**

PA-209 (x 2)  
PA-210 (x 4)

**SUPERIORE / TOP / OBEN**  
734  
102  
PA-209

**INFERIORE / BOTTOM / UNTEN**  
734  
102  
PA-209

**PA-250 ANTA C-10** (for glass 10 mm)  
**PA-250 ANTA C-12** (for glass 12 - 12,7 mm)  
 ANTA INTERMEDIA A LIBRO 2 C  
 MIDDLE FOLDING PANEL 2 C  
 MITTIGES FALTELEMENT 2 C

PA-220 (x 2) PA-223 (x 16)  
 PA-225-10 (x 1) PA-225-12 (x 1) PA-214 (x 1)

SCORREVOLI A LIBRO  
 SLIDING FOLDING SYSTEMS

# PA-250 LIBRO FOLDING

## COME ASSEMBLARE LE ANTE / HOW TO ASSEMBLE THE DOORS / WIE DIE TÜREN ZUSAMMENSETZT WERDEN

TAGLIO PROFILI  
PROFIL PREPARATION / PROFILBEARBEITUNG



KIT ACCESSORI  
ACCESSORY SETS / ZUBEHÖR SETS



ANTA COMPLETA  
COMPLETE DOOR / KOMPLETTE TÜR

ANTA D / DOOR D / TÜRD

PA-209 (2 x)



PA-210 (4 x)

SUPERIORE / TOP / OBEN

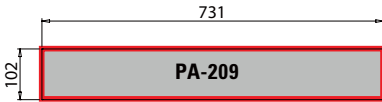

INFERIORE / BOTTOM / UNTEN

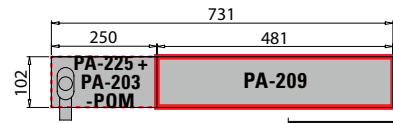

- Lavorazione veletta con PA-210 con PA-225 + PA-203-POM
- Cover profile preparation with PA-210 with PA-225 + PA-203-POM
- Vorbereitung der Abdeckung mit PA-210 mit PA-225 + PA-203-POM

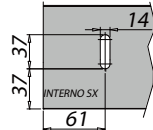

PA-250 ANTA D-10 (for glass 10 mm)

PA-250 ANTA D-12 (for glass 12 - 12,7 mm)

ULTIMA ANTA D (ante pari)

LAST PANEL D (even panels)

ENDSCHIEBEFLÜGEL D (gerade Zahl von Flügeln)

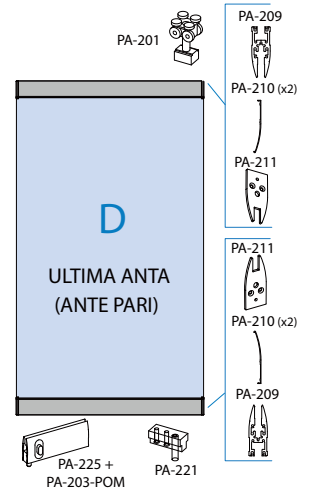
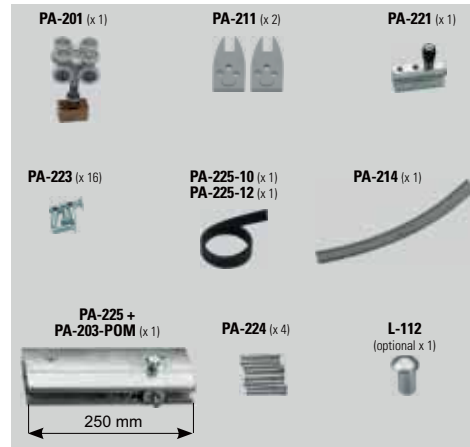

ANTA E / DOOR E / TÜRE

PA-209 (x 2)



PA-210 (x 4)

SUPERIORE / TOP / OBEN

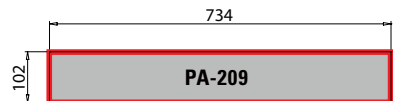

INFERIORE / BOTTOM / UNTEN

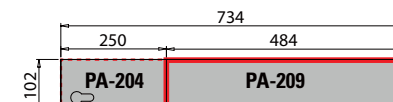

- Lavorazione veletta con PA-204
- Cover profile preparation with PA-204
- Vorbereitung der Abdeckung mit PA-204

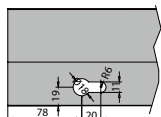

PA-250 ANTA E-10 (for glass 10 mm)

PA-250 ANTA E-12 (for glass 12 - 12,7 mm)

PORTA LATERALE E (ante dispari)

LATERAL PIVOT DOOR E (odd panels)

DREHSCHIEBEFLÜGEL E (ungerade Zahl von Flügeln)

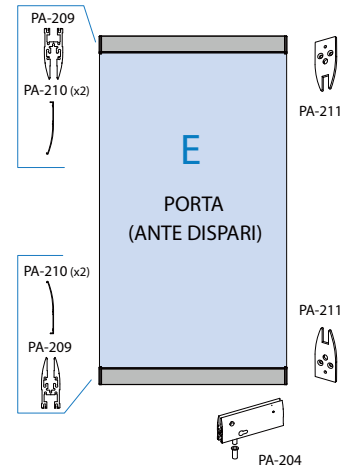
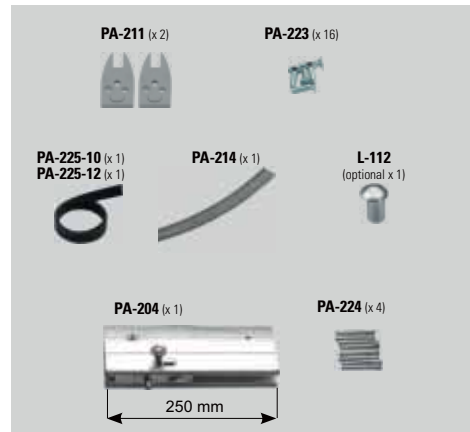

ANTA F / DOOR F / TÜRF

PA-209 (x 2)



PA-210 (x 4)

SUPERIORE / TOP / OBEN

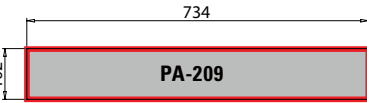

INFERIORE / BOTTOM / UNTEN

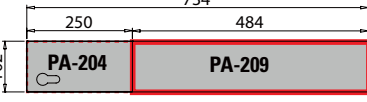

- Lavorazione veletta con PA-204
- Cover profile preparation with PA-204
- Vorbereitung der Abdeckung mit PA-204

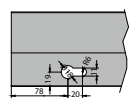

PA-250 ANTA F-10 (for glass 10 mm)

PA-250 ANTA F-12 (for glass 12 - 12,7 mm)

PORTA LATERALE FISSA F

FIXED LATERAL PIVOT DOOR F

FEST DREHFLÜGEL F

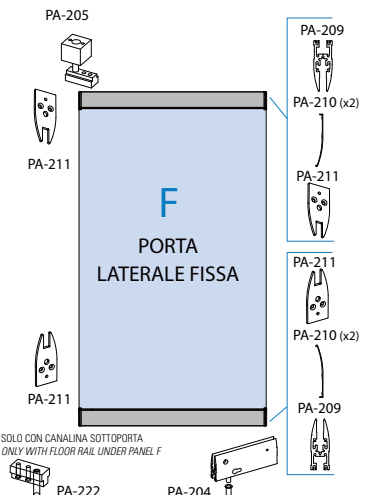
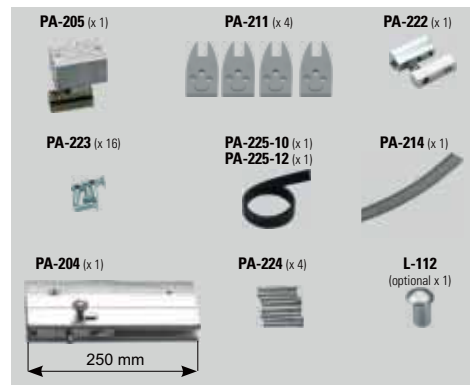

SOLO CON CANALINA SOTTOPIANTA  
ONLY WITH FLOOR RAIL UNDER PANEL F

xme533-b



SCORREVOLI A LIBRO  
SLIDING FOLDING SYSTEMS

# PA-750 LIBRO FOLDING do-it-yourself

SCORREVOLI A LIBRO / SLIDING FOLDING SYSTEMS / FALT-SCHIEBEWANDSYSTEME

MY METALGLAS

€ C.173

NEW



- Sistema scorrevole a libro con profili fermavetro continui a misura standard (mm 1000) da tagliare secondo necessità a cura del cliente, completi di catenaccioli fermaanta a posizionamento esterno regolabile. Vantaggi di una consegna più veloce e di un unico prodotto a magazzino per tutte le misure fino a 800 mm.
- Sliding folding door system with continuous glass fixing profiles of a standard size (mm 1000) to be cut on the basis of client's requirements comes equipped with an adjustable door holding latch positioned externally. The advantage of this product is quick delivery and a unique product available in the warehouse for all sizes up to 800 mm.
- Schiebesystem mit durchgehenden Glasteilenprofilen in Standardgröße (1000 mm), ablängbar, komplett mit äußerem einstellbaren Riegeln zur Flügelstellung. Vorteile einer raschen Lieferung und eines einzigen lagermäßigen Produktes mit Abmessungen bis 800 mm.

SCORREVOLI A LIBRO  
SLIDING FOLDING SYSTEMS

	PA-750 SET 2 (A)(E)
	PA-750 SET 3 (A)(B)(D)
	PA-750 SET 4 (A)(B)(C)(E)
	PA-750 SET 5 (A)(B)(C)(B)(D)
	PA-750 SET 6 (A)(B)(C)(B)(C)(E)
	PA-750 SET 7 (A)(B)(C)(B)(C)(B)(D)

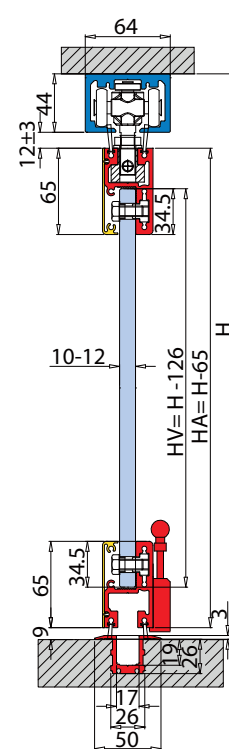

HV = H - 126



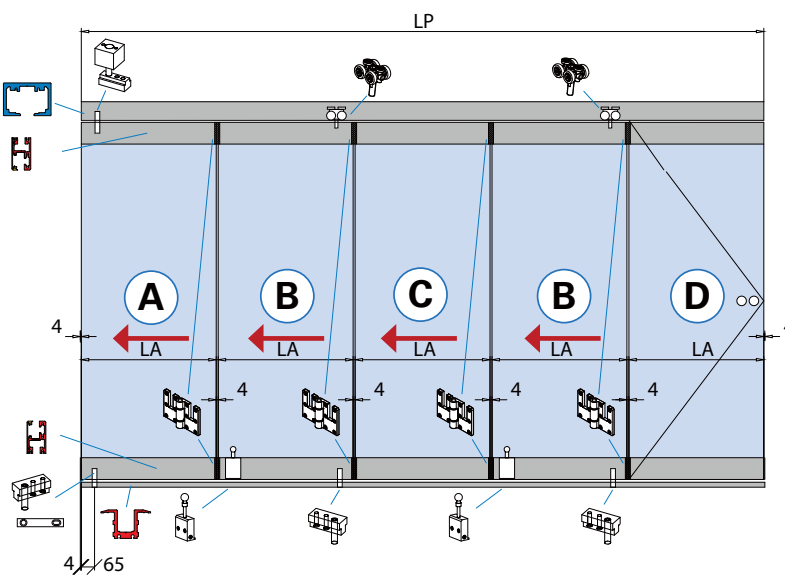
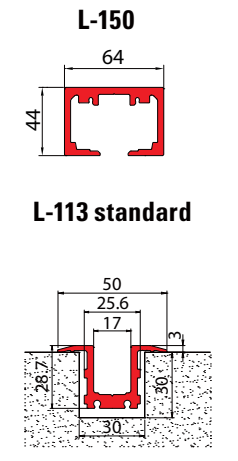
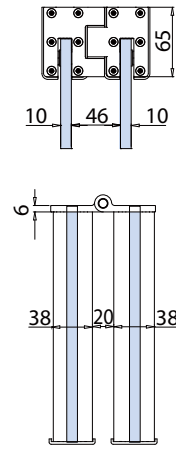
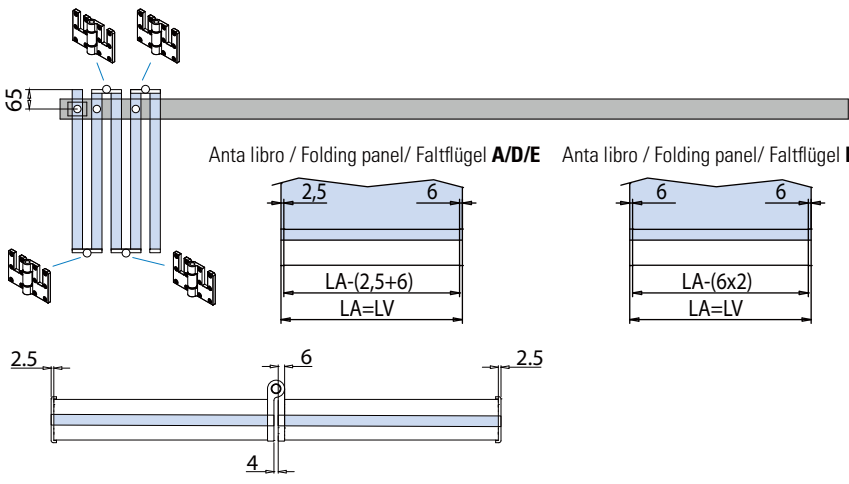
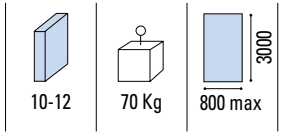
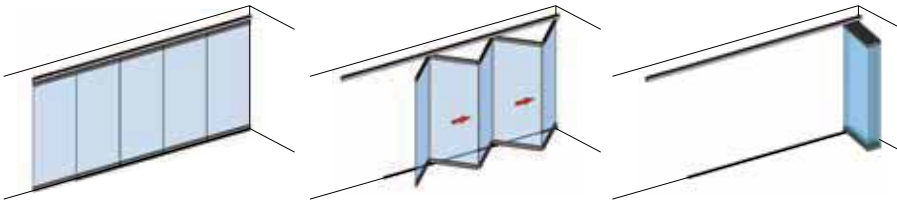

- (A)**
  - Prima anta a libro
  - First folding panel
  - Erster Faltelement
- (B)**
  - Anta intermedia con catenaccio
  - Intermediate panel with locking bolt
  - Mittiges Faltelement mit Riegel
- (C)**
  - Anta intermedia a libro
  - Intermediate folding panel
  - Mittiges Faltelement
- (D)**
  - Ultima anta porta battente con numero ante dispari
  - Last hinged door with odd no. panels
  - Letzter Dreh-Flügel bei ungerader Flügelanzahl
- (E)**
  - Ultima anta con N° ante pari
  - Last panel with even no. panels
  - Letzter Flügel bei gerader Flügelanzahl

LAVORAZIONE VETRO  
GLASS PREPARATION  
GLASBEARBEITUNG

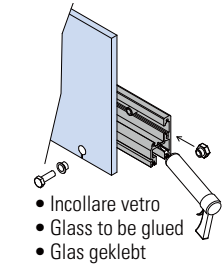
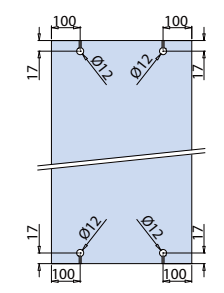

• Calcolo vetro  $At = 4 \times (N + 1)$   
 • Calculation glass  $X = LP - At$   
 • Glasberechnung  $LA = X / N$

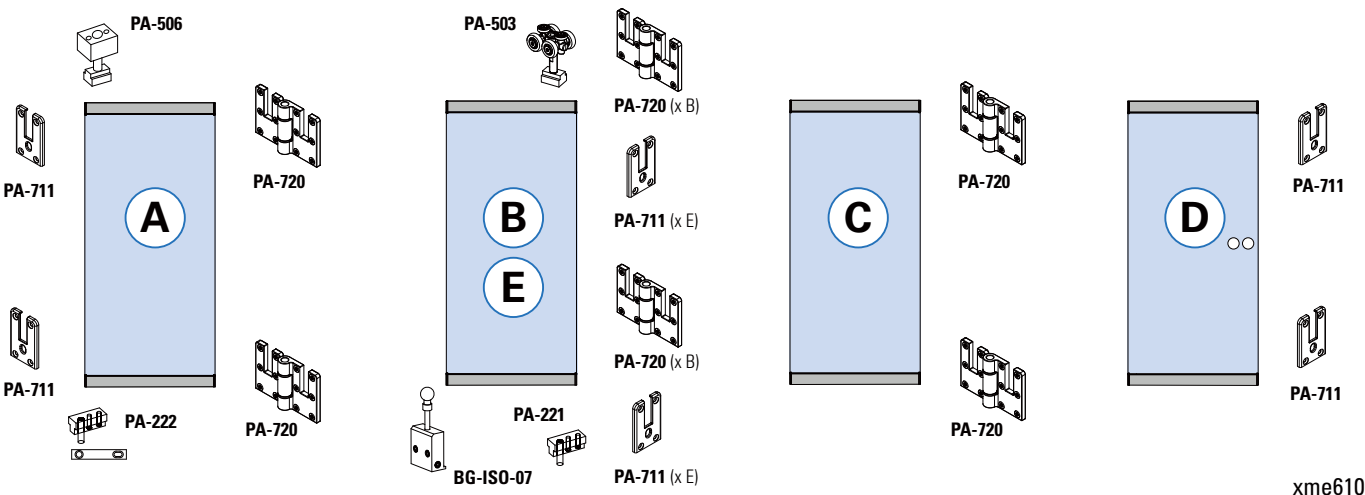

<b>AN</b> Alluminio anodizzato Aluminium anodized Aluminium Silberfarbig	<b>At</b> Arie totali Total clearances Summe alle Abstände Glas/Wand	<b>N</b> Numero ante Numbers panels Anzahl der Elemente	<b>LP</b> Passaggio luce Clear opening width Lichte Durchgangsbreite	<b>LA = LV</b> Larghezza ante = Larghezza vetro Panel width = Glass width Flügelbreite = Glasbreite	<b>H</b> Altezza passaggio luce Clear opening height Lichte durchgangshöhe	<b>HV</b> Altezza vetro Glass height Glashöhe	<b>HA</b> Altezza anta Door height Tür Höhe
---	---	--	---	--	---	--	--

xme610

# PA-750 LIBRO FOLDING do-it-yourself

COME USARE MY METALGLAS / HOW TO USE MY METALGLAS / WIE MAN BENUTZT MY METALGLAS

**1** INSERIRE LE MISURE DEL TUO VANO E LE ANTE DESIDERATE  
ENTER THE MEASUREMENTS OF YOUR OPENING AND THE DOORS YOU REQUIRE  
GEBEN SIE DIE MASSE IHRER ÖFFNUNG EIN UND DIE ERFORDERLICHEN TÜREN

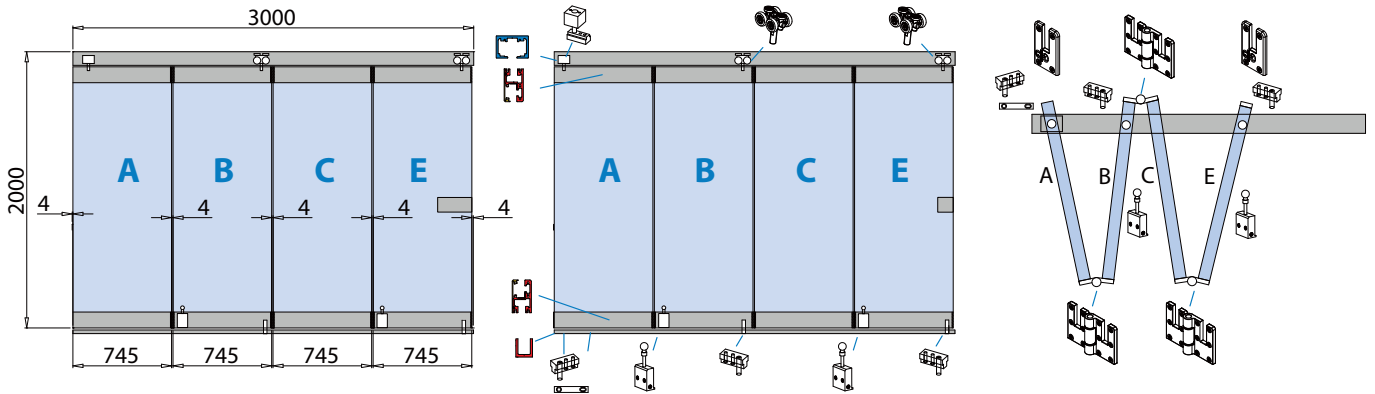

**2** SI OTTENGONO LE MISURE DEI VETRI AUTOMATICAMENTE  
THE MEASUREMENTS OF THE GLASS WILL BE GENERATED AUTOMATICALLY  
DIE ABMESSUNGEN DES GLASES WERDEN AUTOMATISCH BERECHNET

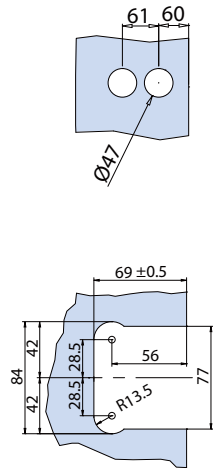
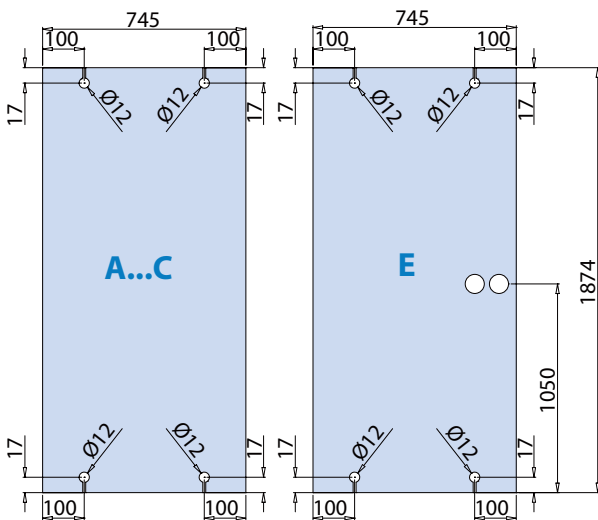

- Foratura vetro porta battente per serrature orizzontali optional
- Glass preparation pivot door for optional horizontal locks
- Glasbearbeitung Dreh-Flügel für optionale horizontale Schlösser

- Foratura vetro porta battente per serrature optional V-504, V-505, V-518, V-519, V-520
- Glass preparation pivot door for optional locks V-504, V-505, V-518, V-519, V-520
- Glasbearbeitung Dreh-Flügel für optionale Schlösser V-504, V-505, V-518, V-519, V-520

**3** SI OTTENGONO LE DISTINTE DI TAGLIO DEI PROFILI, DA ABBINARE AGLI ACCESSORI  
THE CUTTING SPECIFICATIONS OF THE PROFILES ARE OBTAINED, FOR MATCHING WITH THE ACCESSORIES  
SIE ERHALTEN EINE SPEZIFIKATION DER PROFILLÄNGEN ZUM ABGLEICHEN MIT DEM ZUBEHÖR

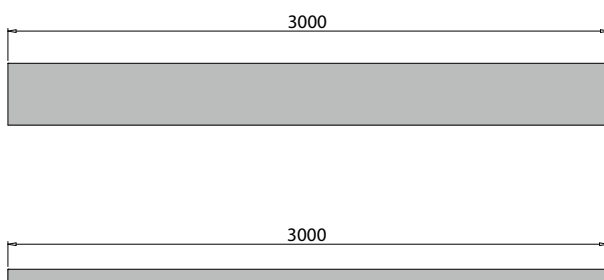







**L-150**



**L-113**



	PA-750 SET 2 (A)(E)
	PA-750 SET 3 (A)(B)(D)
	PA-750 SET 4 (A)(B)(C)(E)
	PA-750 SET 5 (A)(B)(C)(B)(D)
	PA-750 SET 6 (A)(B)(C)(B)(C)(E)
	PA-750 SET 7 (A)(B)(C)(B)(C)(B)(D)

# PA-750 LIBRO FOLDING do-it-yourself

COME ASSEMBLARE LE ANTE / HOW TO ASSEMBLE THE DOORS / WIE DIE TÜREN ZUSAMMENSETZT WERDEN

TAGLIO PROFILI  
PROFIL PREPARATION / PROFILBEARBEITUNG



KIT ACCESSORI  
ACCESSORY SETS / ZUBEHÖR SETS



ANTA COMPLETA  
COMPLETE DOOR / KOMPLETTE TÜR

ANTA A / DOOR A / TÜRA

PA-730 (x 2)



SUPERIORE / TOP / OBEN

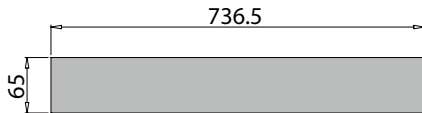

INFERIORE / BOTTOM / UNTEN

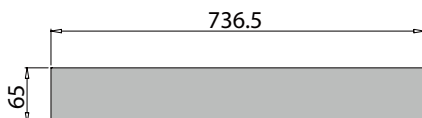

PA-750 ANTA A (for glass 10/12 mm)

PRIMA ANTA A LIBRO A  
FIRST FOLDING PANEL A  
ESTES FALTELEMENT A

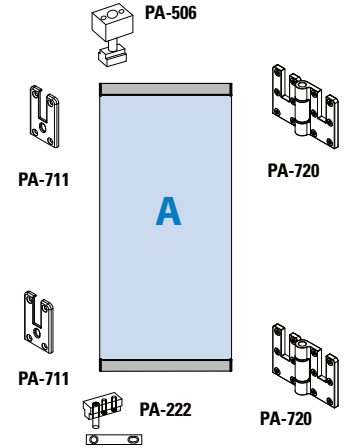
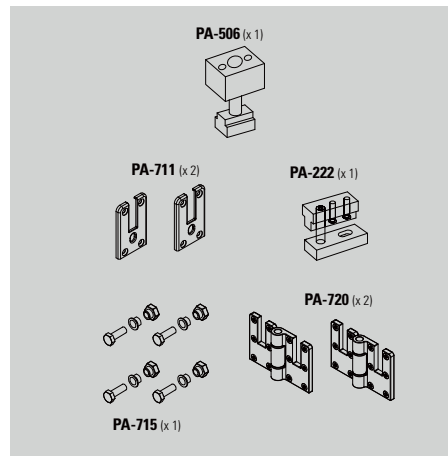

ANTA B / DOOR B / TÜRB

PA-730 (x 2)



SUPERIORE / TOP / OBEN

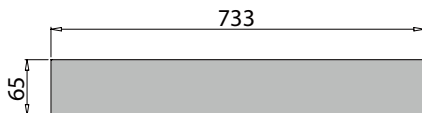

INFERIORE / BOTTOM / UNTEN

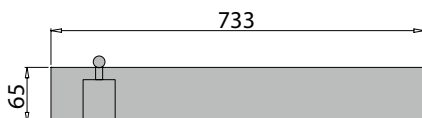

PA-750 ANTA B (for glass 10/12 mm)

ANTA INTERMEDIA A LIBRO B  
INTERMEDIATE FOLDING PANEL B  
MITTIGES FALTELEMENT B

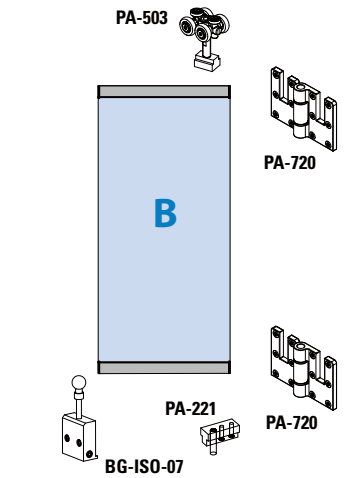
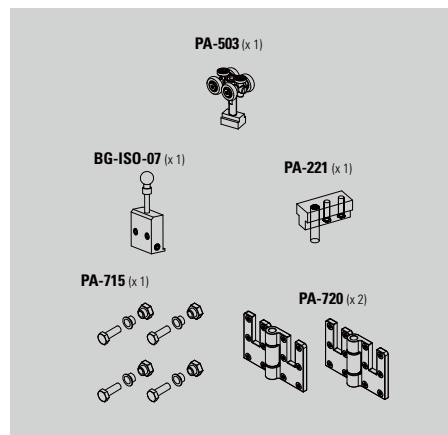

ANTA C / DOOR C / TÜRC

PA-730 (x 2)



SUPERIORE / TOP / OBEN

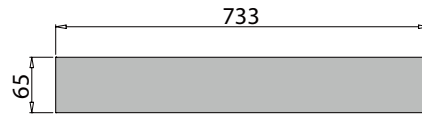

INFERIORE / BOTTOM / UNTEN

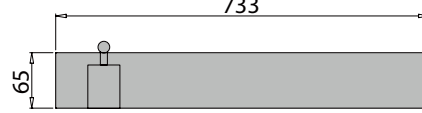

PA-750 ANTA C (for glass 10/12 mm)

ANTA INTERMEDIA A LIBRO 2 C  
INTERMEDIATE FOLDING PANEL 2 C  
MITTIGES FALTELEMENT 2 C

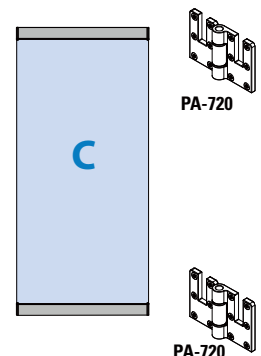
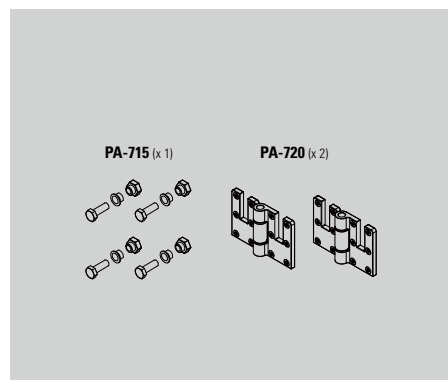

SCORREVOLI A LIBRO  
SLIDING FOLDING SYSTEMS

# PA-750 LIBRO FOLDING do-it-yourself

## COME ASSEMBLARE LE ANTE / HOW TO ASSEMBLE THE DOORS / WIE DIE TÜREN ZUSAMMENSETZT WERDEN

TAGLIO PROFILI  
PROFILES PREPARATION / PROFILEBEARBEITUNG



KIT ACCESSORI  
ACCESSORY SETS / ZUBEHÖR SETS



ANTA COMPLETA  
COMPLETE DOOR / KOMPLETTE TÜR

ANTA D / DOOR D / TÜRD

PA-730 (x 2)



SUPERIORE / TOP / OBEN

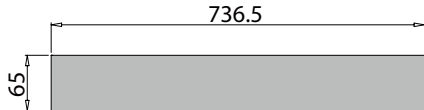

INFERIORE / BOTTOM / UNTEN

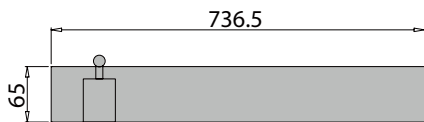

**PA-750 ANTA D** (for glass 10/12 mm)  
ULTIMA ANTA D (ante dispari)  
LAST PANEL D (odd panels)  
ENDSCHIEBEFLÜGEL D (ungerade Zahl von Flügel)

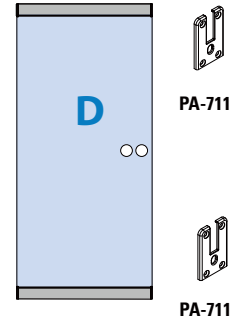
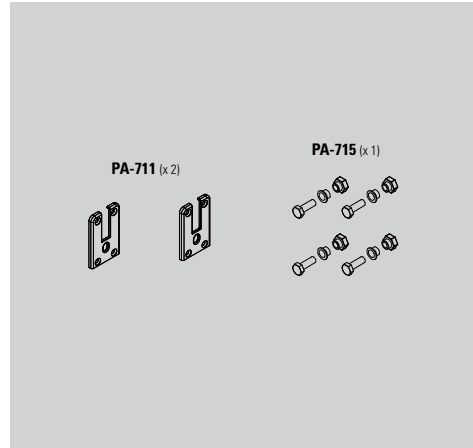

PA-711

PA-711

ANTA E / DOORE / TÜRE

PA-730 (x 2)



SUPERIORE / TOP / OBEN

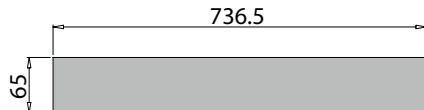

INFERIORE / BOTTOM / UNTEN

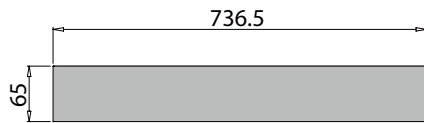

**PA-750 ANTA E** (for glass 10/12 mm)  
PORTA LATERALE E (ante pari)  
LATERAL PIVOT DOOR E (even panels)  
DREHSCHIEBEFLÜGEL E (gerade Zahl von Flügel)

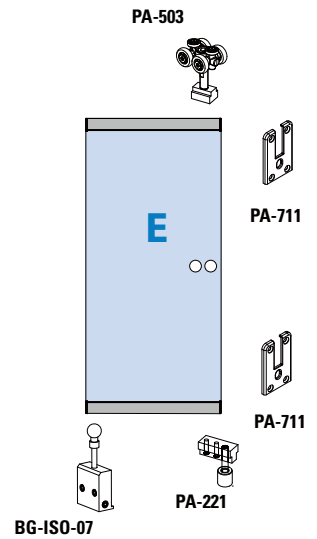
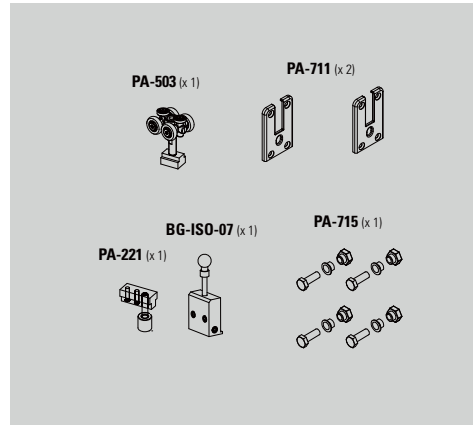

PA-503

PA-711

PA-711

BG-ISO-07

PA-221

ANTA F / DOOR F / TÜRF

PA-730 (x 2)



SUPERIORE / TOP / OBEN

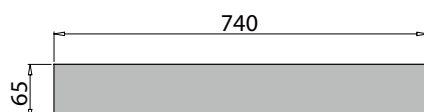

INFERIORE / BOTTOM / UNTEN

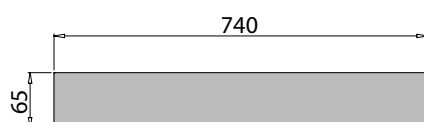

**PA-750 ANTA F** (for glass 10/12 mm)  
PORTA LATERALE FISSA F  
FIXED LATERAL PIVOT DOOR F  
FEST DREHFLÜGEL F

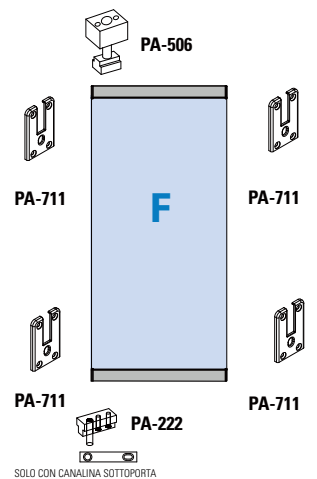
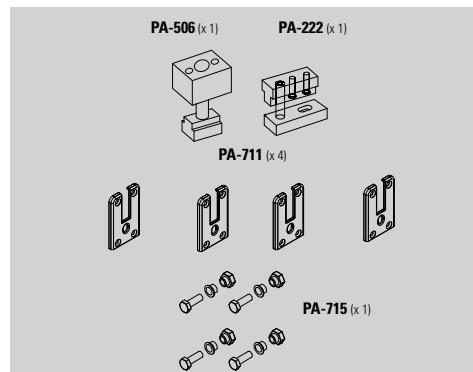

PA-506

PA-711

PA-711

PA-711

PA-711

SOLO CON CANALINA SOTTOPORTA  
ONLY WITH FLOOR RAIL UNDER PANEL F

xm610d



SCORREVOLI A LIBRO  
SLIDING FOLDING SYSTEMS

# PA-450 LIBRO FOLDING do-it-yourself

€▶ C.187

SCORREVOLI A LIBRO / SLIDING FOLDING SYSTEMS / FALT-SCHIEBEWANDSYSTEME



- Sistema scorrevole modulare a libro con morsetti fermavetro (mm 250) e veletta continua (mm 1200) da tagliare secondo necessità a cura del cliente.
- Sliding folding door system with glass fixing clamps (mm 250) and continuous covers (mm 1200) to be cut on the basis of client's requirements.
- Modulares Schiebesystem mit Glashalteklammern (250 mm) und kontinuierlicher Verkleidung (1200 mm), kundenspezifisch ablängbar.

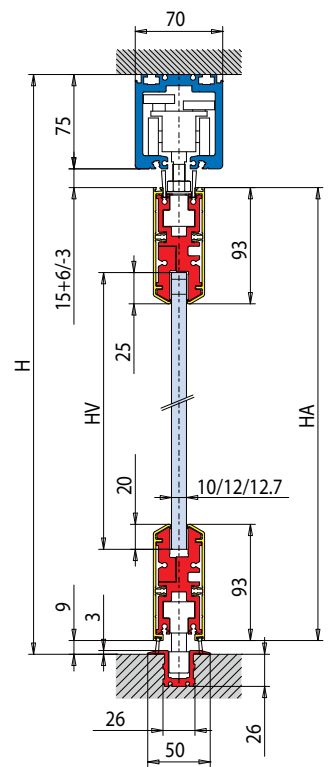

HV = H - 240  
HA = H - 100



LAVORAZIONE VETRO x 2  
GLASS PREPARATION x 2  
GLASBEARBEITUNG x 2

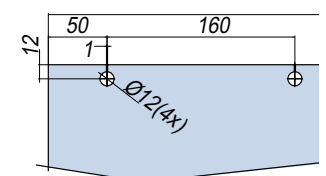

SCORREVOLI A LIBRO  
SLIDING FOLDING SYSTEMS

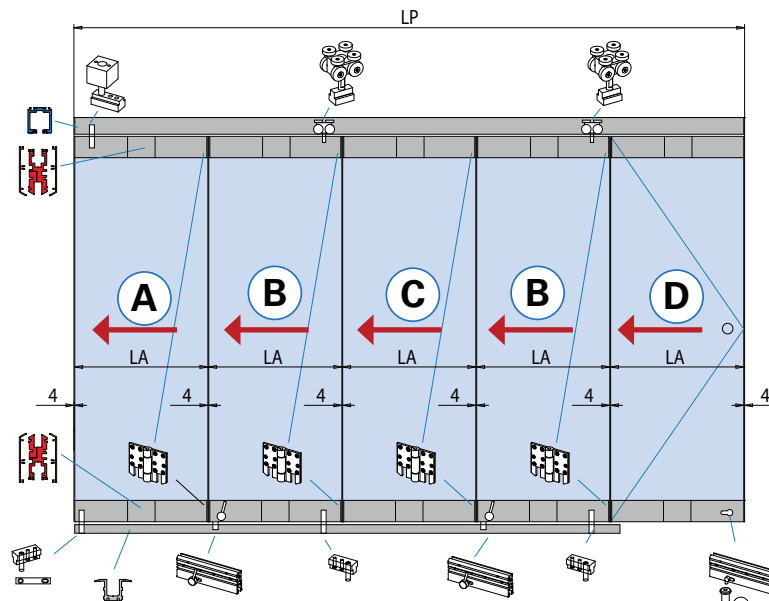
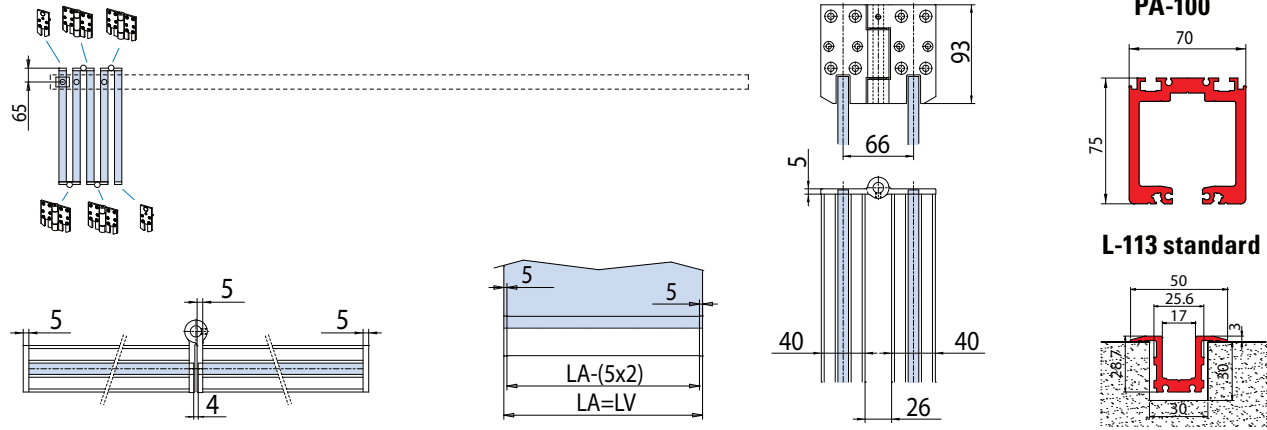
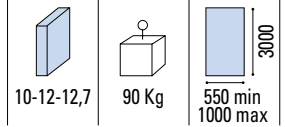
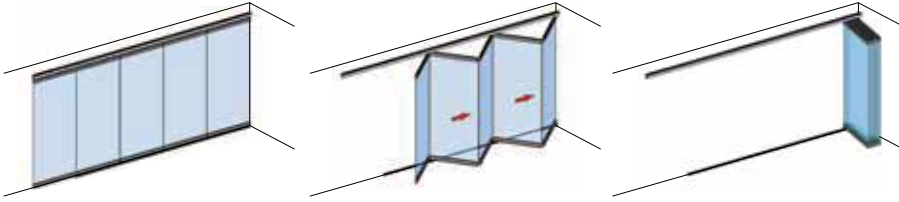

Calcolo vetro  
Calculation glass  
Glasberechnung

$$At = 4 \times (N + 1)$$

$$X = LP - At$$

$$LA = LV = X / N$$

- (A)**
- Prima anta a libro
- First folding panel
- Erster Faltelement

- (B) (C)**
- Anta intermedia a libro
- Intermediate folding panel
- Mittiges Faltelement

- (D)**
- Ultima anta porta battente con numero ante dispari
- Last hinged door with odd no. panels
- Letzter Dreh-Flügel bei ungerader Flügelanzahl

- (E)**
- Ultima anta con N° ante pari
- Last panel with even no. panels
- Letzter Flügel bei gerader Flügelanzahl

	PA-450 SET 2 (A E)
	PA-450 SET 3 (A B D)
	PA-450 SET 4 (A B C E)
	PA-450 SET 5 (A B C B D)
	PA-450 SET 6 (A B C B C E)
	PA-450 SET 7 (A B C B C B D)

SCORREVOLI A LIBRO  
SLIDING FOLDING SYSTEMS

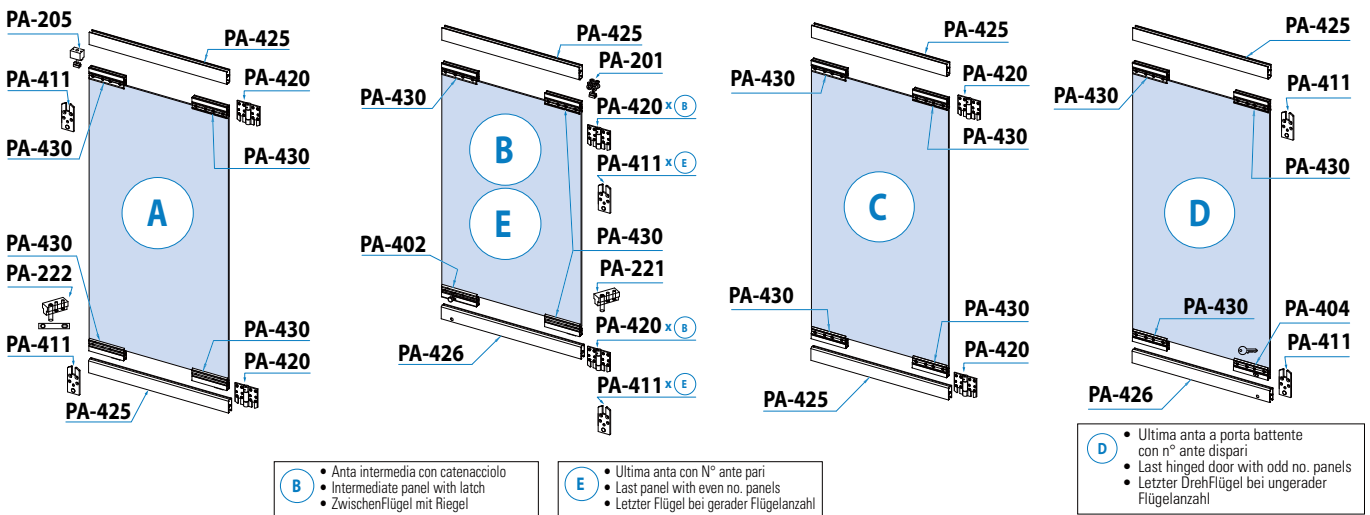

- (B)**
  - Anta intermedia con catenacciolo
  - Intermediate panel with latch
  - Zwischenflügel mit Riegel
- (E)**
  - Ultima anta con N° ante pari
  - Last panel with even no. panels
  - Letzter Flügel bei gerader Flügelanzahl

- (D)**
  - Ultima anta a porta battente con n° ante dispari
  - Last hinged door with odd no. panels
  - Letzter Drehflügel bei ungerader Flügelanzahl

xla334-0 / xla334g / xla334c

AN	At	N	LP	LA = LV	H	HV	HA
Alluminio anodizzato Aluminium anodized Aluminium Silberfarbig	Arie totali Total clearances Summe alle Abstände Glas/Wand	Numero ante Numbers panels Anzahl der Elemente	Passaggio luce Clear opening width Lichte Durchgangsbreite	Larghezza ante = Larghezza vetro Panel width = Glass width Flügelbreite = Glasbreite	Altezza passaggio luce Clear opening height Lichte durchgangshöhe	Altezza vetro Glass height Glashöhe	Altezza anta Door height Tür Höhe

# PA-550 LIBRO FOLDING do-it-yourself

SCORREVOLI A LIBRO / SLIDING FOLDING SYSTEMS / FALT-SCHIEBEWANDSYSTEME

**MY METALGLAS**

€ C.201



- Sistema scorrevole a libro con profili fermavetro continui a misura standard (mm 1000) da tagliare secondo necessità a cura del cliente, completi di catenaccioli fermaanta a posizionamento esterno regolabile. Vantaggi di una consegna più veloce e di un unico prodotto a magazzino per tutte le misure fino a 1000 mm.
- Sliding folding door system with continuous glass fixing profiles of a standard size (mm 1000) to be cut on the basis of client's requirements comes equipped with an adjustable door holding latch positioned externally. The advantage of this product is quick delivery and a unique product available in the warehouse for all sizes up to 1000 mm.
- Schiebesystem mit durchgehenden Glasteilenprofilen in Standardgröße (1000 mm), ablängbar, komplett mit äußerer einstellbaren Riegeln zur Flügelfeststellung. Vorteile einer raschen Lieferung und eines einzigen lagermäßigen Produktes mit Abmessungen bis 1000 mm.

SCORREVOLI A LIBRO  
SLIDING FOLDING SYSTEMS

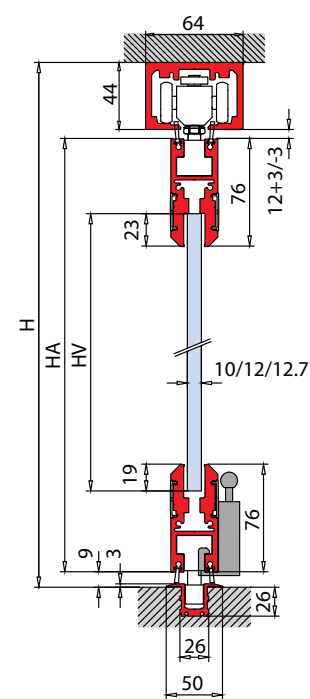

$HV = H - 176$



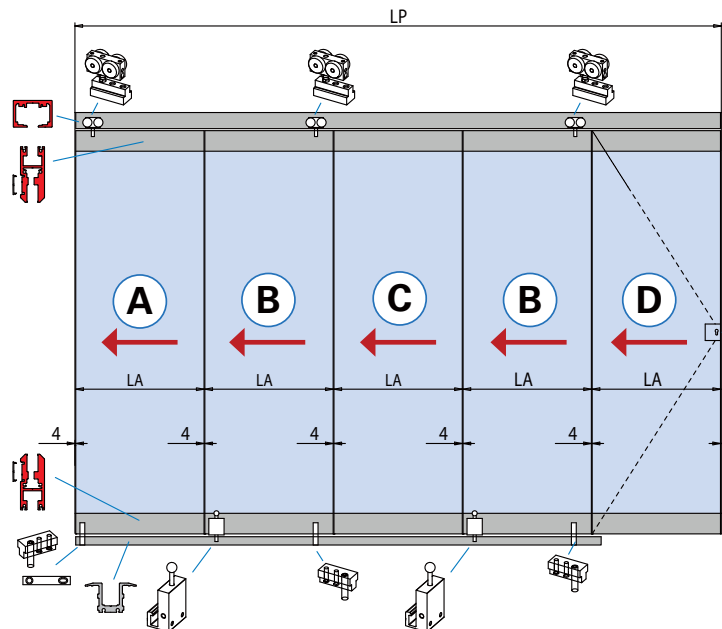
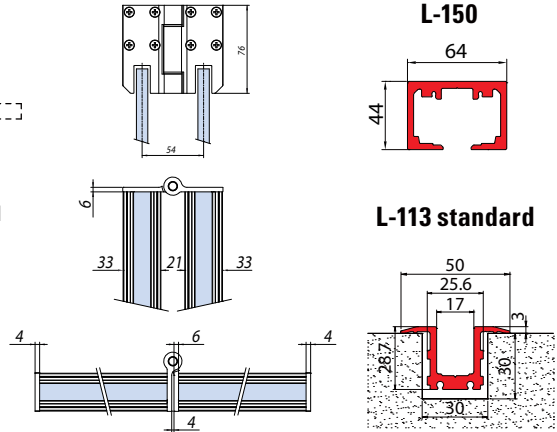
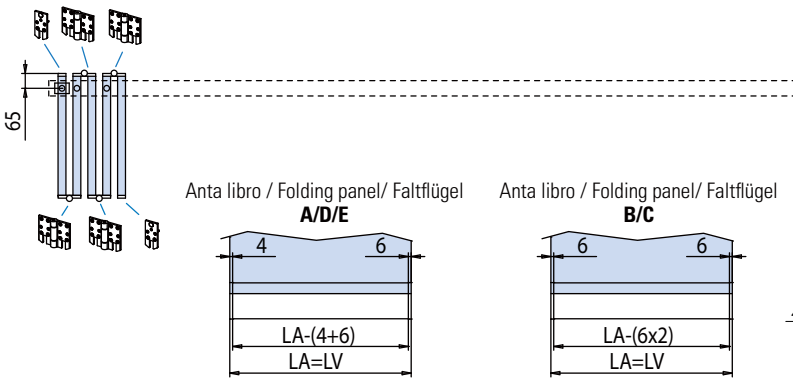
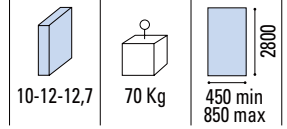
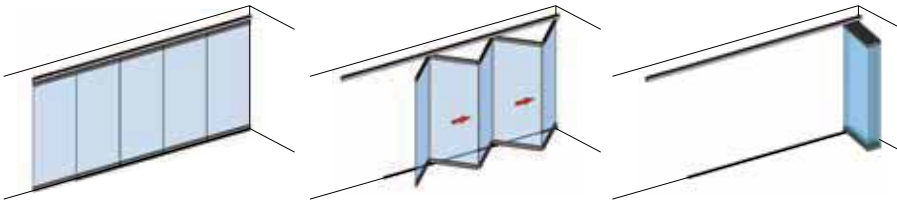

- Calcolo vetro
  - Calculation glass
  - Glasberechnung
- At = 4 x (N + 1)  
X = LP - At  
LA = LV = X / N

- PA-550 SET 2 (A E)
- PA-550 SET 3 (A B D)
- PA-550 SET 4 (A B C E)
- PA-550 SET 5 (A B C B D)
- PA-550 SET 6 (A B C B C E)
- PA-550 SET 7 (A B C B C B D)

- A**
- Prima anta a libro
  - First folding panel
  - Erster Faltelement
- B C**
- Anta intermedia a libro
  - Intermediate folding panel
  - Mittiges Faltelement
- D**
- Ultima anta porta battente con numero ante dispari
  - Last hinged door with odd no. panels
  - Letzter Dreh-Flügel bei ungerader Flügelanzahl
- E**
- Ultima anta con N° ante pari
  - Last panel with even no. panels
  - Letzter Flügel bei gerader Flügelanzahl

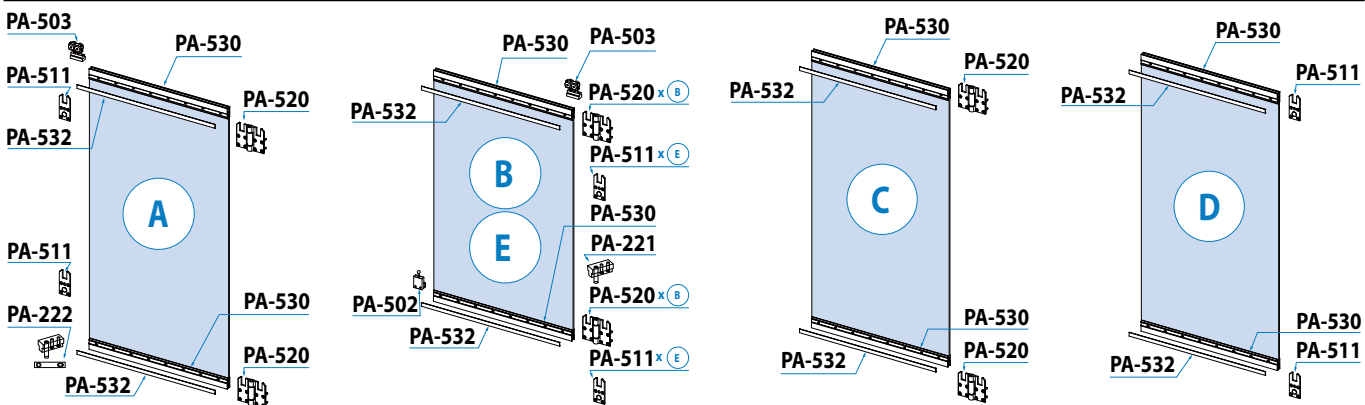

- B**
- Anta intermedia con catenaccio
  - Intermediate panel with latch
  - Zwischenflügel mit Riegel
- E**
- Ultima anta con N° ante pari
  - Last panel with even no. panels
  - Letzter Flügel bei gerader Flügelanzahl
- D**
- Ultima anta a porta battente con n° ante dispari
  - Last hinged door with odd no. panels
  - Letzter Drehflügel bei ungerader Flügelanzahl

xla342c-new / xla342c / xla342e / xla342-0

AN	At	N	LP	LA = LV	H	HV	HA
Alluminio anodizzato	Arie totali	Numero ante	Passaggio luce	Larghezza ante = Larghezza vetro	Altezza passaggio luce	Altezza vetro	Altezza anta
Aluminium anodized	Total clearances	Numbers panels	Clear opening width	Panel width = Glass width	Clear opening height	Glass height	Door height
Aluminium Silberfarbig	Summe alle Abstände Glas/Wand	Anzahl der Elemente	Lichte Durchgangsbreite	Flügelbreite = Glasbreite	Lichte durchgangshöhe	Glashöhe	Tür Höhe

SCORREVOLI A LIBRO SLIDING FOLDING SYSTEMS

# PA-550 LIBRO FOLDING do-it-yourself

COME USARE MY METALGLAS / HOW TO USE MY METALGLAS / WIE MAN BENUTZT MY METALGLAS

**1** INSERIRE LE MISURE DEL TUO VANO E LE ANTE DESIDERATE  
ENTER THE MEASUREMENTS OF YOUR OPENING AND THE DOORS YOU REQUIRE  
GEBEN SIE DIE MASSE IHRER ÖFFNUNG EIN UND DIE ERFORDERLICHEN TÜREN

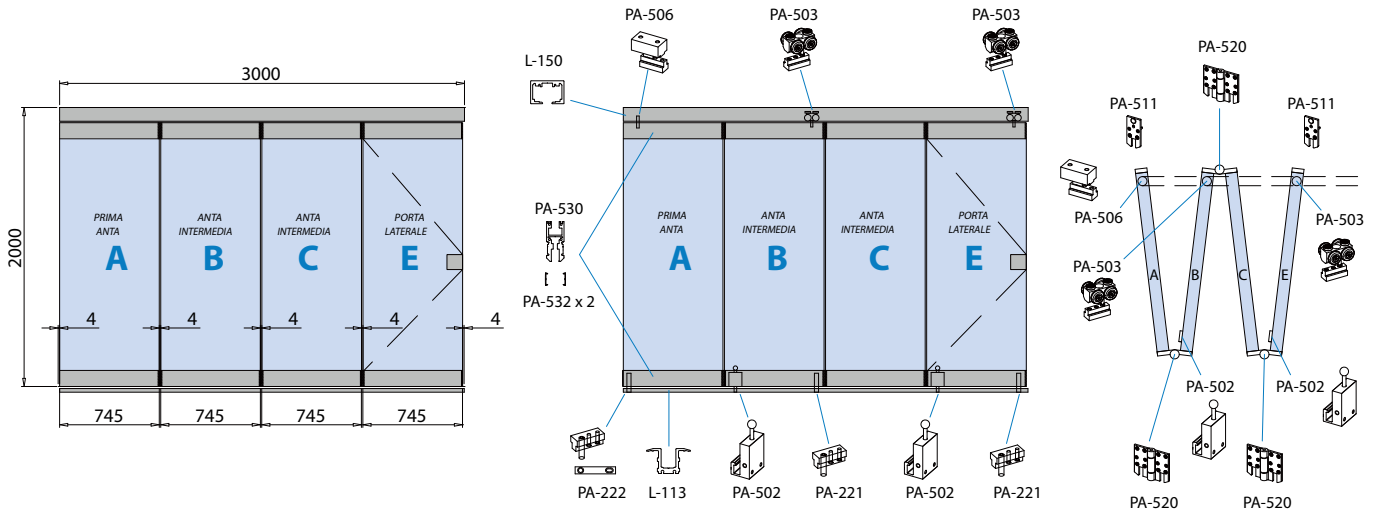

**2** SI OTTENGONO LE MISURE DEI VETRI AUTOMATICAMENTE  
THE MEASUREMENTS OF THE GLASS WILL BE GENERATED AUTOMATICALLY  
DIE ABMESSUNGEN DES GLASES WERDEN AUTOMATISCH BERECHNET

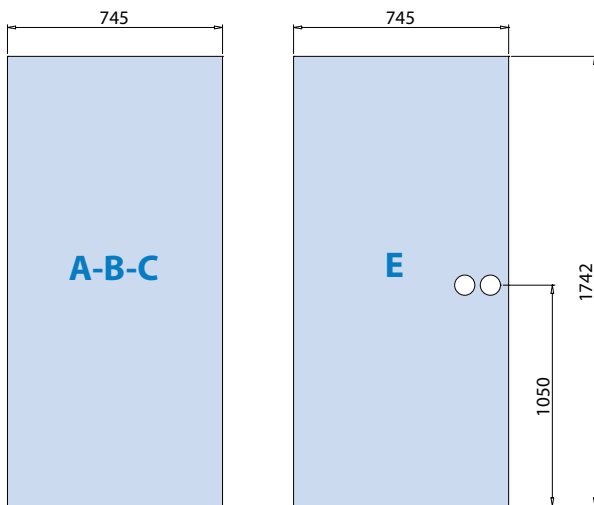

- Foratura vetro porta battente per serrature orizzontali optional
- Glass preparation pivot door for optional horizontal locks
- Glasbearbeitung Dreh-Flügel für optionale horizontale Schlösser

- Foratura vetro porta battente per serrature optional V-504, V-505, V-518, V-519, V-520
- Glass preparation pivot door for optional locks V-504, V-505, V-518, V-519, V-520
- Glasbearbeitung Dreh-Flügel für optionale Schlösser V-504, V-505, V-518, V-519, V-520

**3** SI OTTENGONO LE DISTINTE DI TAGLIO DEI PROFILI, DA ABBINARE AGLI ACCESSORI  
THE CUTTING SPECIFICATIONS OF THE PROFILES ARE OBTAINED, FOR MATCHING WITH THE ACCESSORIES  
SIE ERHALTEN EINE SPEZIFIKATION DER PROFILLÄNGEN ZUM ABGLEICHEN MIT DEM ZUBEHÖR

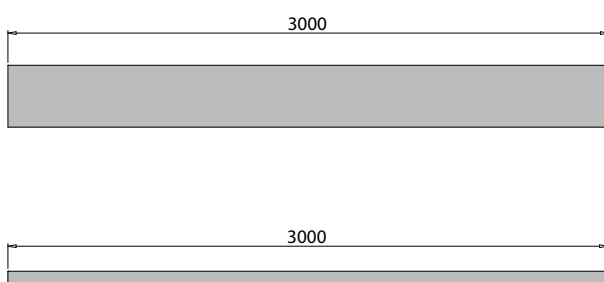

L-150



L-113



	PA-550 SET 2 (A)(E)
	PA-550 SET 3 (A)(B)(D)
	PA-550 SET 4 (A)(B)(C)(E)
	PA-550 SET 5 (A)(B)(C)(B)(D)
	PA-550 SET 6 (A)(B)(C)(B)(C)(E)
	PA-550 SET 7 (A)(B)(C)(B)(C)(B)(D)

# PA-550 LIBRO FOLDING do-it-yourself

## COME ASSEMBLARE LE ANTE / HOW TO ASSEMBLE THE DOORS / WIE DIE TÜREN ZUSAMMENSETZT WERDEN

TAGLIO PROFILI  
PROFIL PREPARATION / PROFILBEARBEITUNG



KIT ACCESSORI  
ACCESSORY SETS / ZUBEHÖR SETS



ANTA COMPLETA  
COMPLETE DOOR / KOMPLETTE TÜR

ANTA A / DOOR A / TÜRA

PA-530  
PA-532 (x 2)

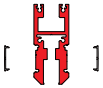

SUPERIORE / TOP / OBEN

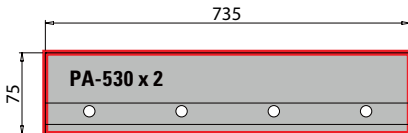

INFERIORE / BOTTOM / UNTEN

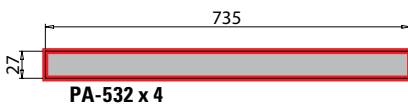

PA-550 ANTA A-10 (for glass 10 mm)  
PA-550 ANTA A-12 (for glass 12 - 12,7 mm)  
PRIMA ANTA A LIBRO A  
FIRST FOLDING PANEL A  
RSTER FALTELEMENT A

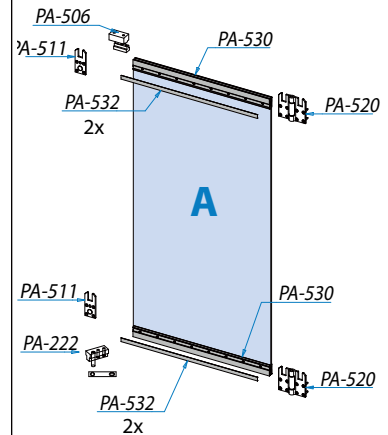

ANTA B / DOOR B / TÜRB

PA-530  
PA-532 (x 2)

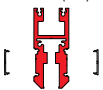

SUPERIORE / TOP / OBEN

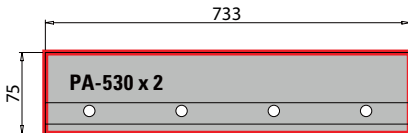

INFERIORE / BOTTOM / UNTEN

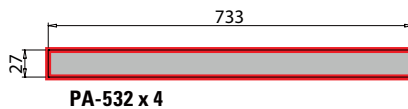

PA-550 ANTA B-10 (for glass 10 mm)  
PA-550 ANTA B-12 (for glass 12 - 12,7 mm)  
ANTA INTERMEDIA A LIBRO B  
MIDDLE FOLDING PANEL B  
MITTIGES FALTELEMENT B

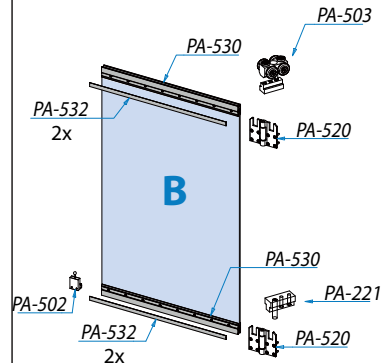

ANTA C / DOOR C / TÜRC

PA-530  
PA-532 (x 2)

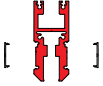

SUPERIORE / TOP / OBEN

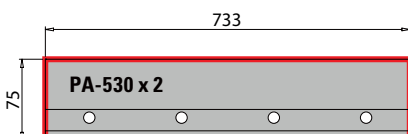

INFERIORE / BOTTOM / UNTEN

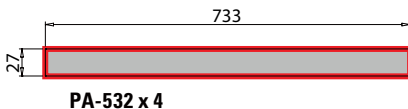

PA-550 ANTA C-10 (for glass 10 mm)  
PA-550 ANTA C-12 (for glass 12 - 12,7 mm)  
ANTA INTERMEDIA A LIBRO 2 C  
MIDDLE FOLDING PANEL 2 C  
MITTIGES FALTELEMENT 2 C

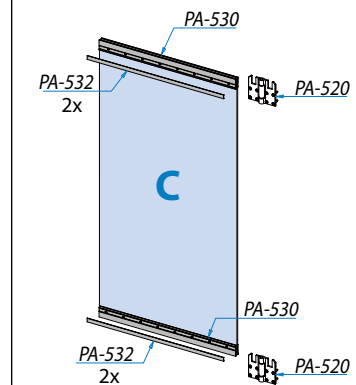

SCORREVOLI A LIBRO  
SLIDING FOLDING SYSTEMS

# PA-550 LIBRO FOLDING do-it-yourself

COME ASSEMBLARE LE ANTE / HOW TO ASSEMBLE THE DOORS / WIE DIE TÜREN ZUSAMMENSETZT WERDEN

TAGLIO PROFILI  
PROFILES PREPARATION / PROFILEBEARBEITUNG



KIT ACCESSORI  
ACCESSORY SETS / ZUBEHÖR SETS



ANTA COMPLETA  
COMPLETE DOOR / KOMPLETTE TÜR

ANTA D / DOOR D / TÜRD

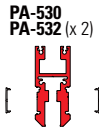

SUPERIORE / TOP / OBEN

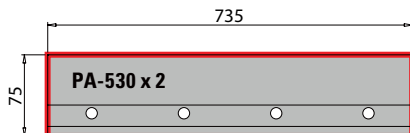

INFERIORE / BOTTOM / UNTEN

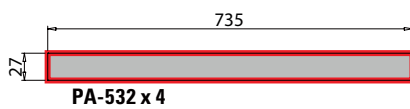

**PA-550 ANTA D-10** (for glass 10 mm)  
**PA-550 ANTA D-12** (for glass 12 - 12,7 mm)  
ULTIMA ANTA D (ante dispari)  
LAST PANEL D (odd panels)  
ENDSCHIEBEFLÜGEL D (ungerade Zahl von Flügel)

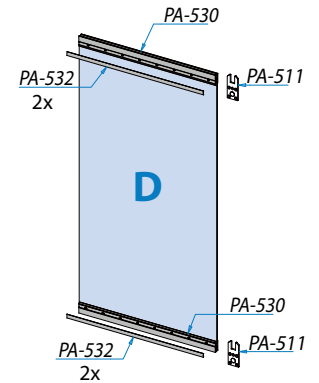

ANTA E / DOOR E / TÜRE



SUPERIORE / TOP / OBEN

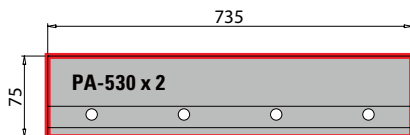

INFERIORE / BOTTOM / UNTEN

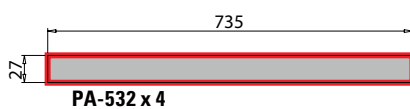

**PA-550 ANTA E-10** (for glass 10 mm)  
**PA-550 ANTA E-12** (for glass 12 - 12,7 mm)  
PORTA LATERALE E (ante pari)  
LATERAL PIVOT DOOR E (even panels)  
DREHSCHIEBEFLÜGEL E (gerade Zahl von Flügel)

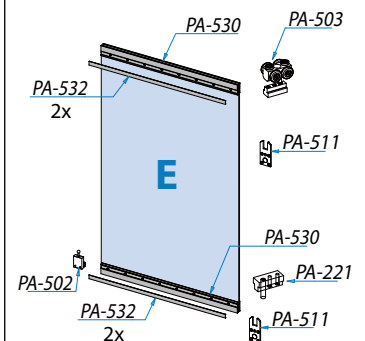

ANTA F / DOOR F / TÜRF



SUPERIORE / TOP / OBEN

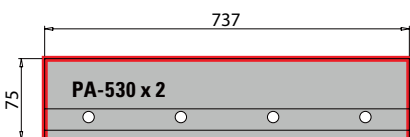

INFERIORE / BOTTOM / UNTEN

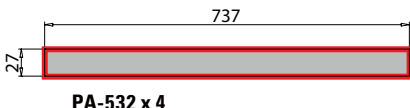

**PA-550 ANTA F-10** (for glass 10 mm)  
**PA-550 ANTA F-12** (for glass 12 - 12,7 mm)  
PORTA LATERALE FISSA F  
FIXED LATERAL PIVOT DOOR F  
FEST DREHSCHIEBEFLÜGEL F

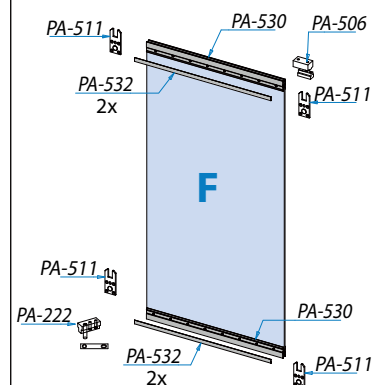

SOLO CON CANALINA SOTTOPORTA  
ONLY WITH FLOOR RAIL UNDER PANEL F

xme534



SCORREVOLI A LIBRO  
SLIDING FOLDING SYSTEMS

## PA-650

€ C.216

SCORREVOLI A LIBRO / SLIDING FOLDING SYSTEMS / FALT-SCHIEBEWANDSYSTEME



- Sistema scorrevole a libro per vetro forti spessori con profili fermavetro continui a misura cliente, completi di catenaccioli ferma anta a posizionamento esterno regolabile.
- Sliding folding door system for thickness 16,76 and 17,52 mm. with glass fixing profiles made to measure upon client's request with an adjustable door holding latch positioned externally.
- Schiebesystem für Glasdicke 16,76 und 17,52 mm. mit durchgehenden kundenspezifischen Glasleistenprofilen, komplett mit äußeren einstellbaren Riegeln zur Flügelfeststellung.

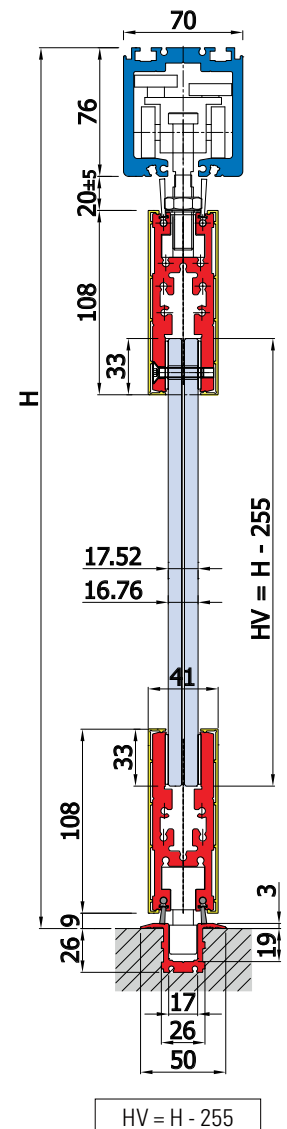

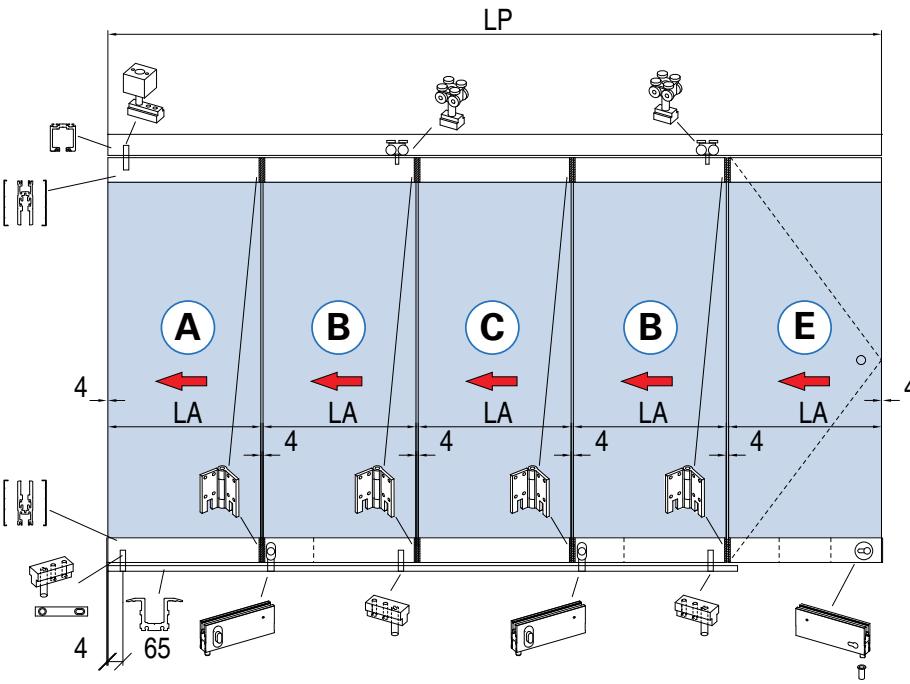
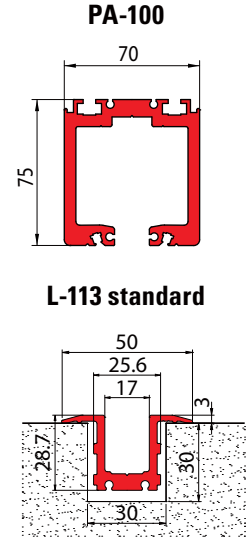
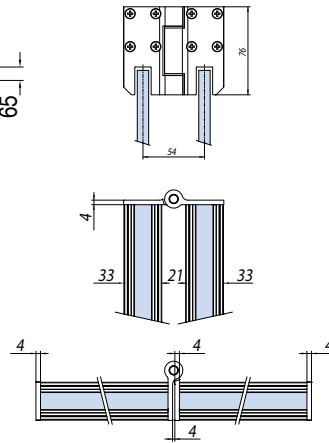
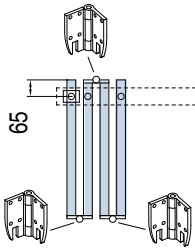
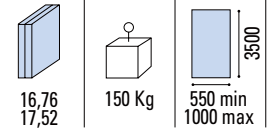
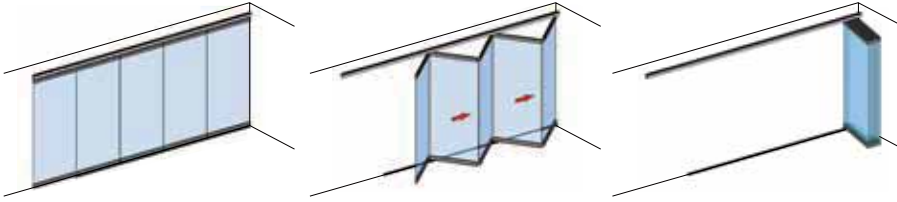

- Calcolo vetro
- Calculation glass
- Glasberechnung

At = 4 x (N + 1)  
 X = LP - At  
 LA = LV = X / N

	PA-650 SET 2 (A/D)
	PA-650 SET 3 (A/B/E)
	PA-650 SET 4 (A/B/C/D)
	PA-650 SET 5 (A/B/C/B/E)
	PA-650 SET 6 (A/B/C/B/C/D)
	PA-650 SET 7 (A/B/C/B/C/B/E)

- (A)**
  - Prima anta a libro
  - First folding panel
  - Erster Faltelement
- (B C)**
  - Anta intermedia a libro
  - Intermediate folding panel
  - Mittiges Faltelement
- (D)**
  - Ultima anta porta battente con numero ante pari
  - Last hinged door with even no. panels
  - Letzter Dreh-Flügel bei gerader Flügelanzahl
- (E)**
  - Ultima anta con N° ante dispari
  - Last panel with odd no. panels
  - Letzter Flügel bei ungerader Flügelanzahl



AN	At	N	LP	LA = LV	H	HV	HA
Alluminio anodizzato	Arie totali	Numero ante	Passaggio luce	Larghezza ante = Larghezza vetro	Altezza passaggio luce	Altezza vetro	Altezza anta
Aluminium anodized	Total clearances	Numbers panels	Clear opening width	Panel width = Glass width	Clear opening height	Glass height	Door height
Aluminium Silberfarbig	Summe alle Abstände Glas/Wand	Anzahl der Elemente	Lichte Durchgangsbreite	Flügelbreite = Glasbreite	Lichte durchgangshöhe	Glashöhe	Tür Höhe

# L-1500 LIBRO FOLDING

SCORREVOLI A LIBRO / SLIDING FOLDING SYSTEMS / FALT-SCHIEBEWANDSYSTEME

**MY METALGLAS**

€▶ C.230



- Sistema scorrevole a libro con cerniere a vista e fori nel vetro, completo di binario standard h=44 mm x L=64 mm e carrello con 4 ruote.
- Sliding folding door system with visible hinges and holes in glass, including standard rail h=44 mm x L=64 mm and carriage with 4 wheels.
- Faltschiebewandssystem mit sichtbaren Bändern und Glasbohrungen, komplett mit Standard-Laufschiene h=44 mm x L=64 mm und Laufwagen mit 4 Rädern.

SCORREVOLI A LIBRO  
SLIDING FOLDING SYSTEMS

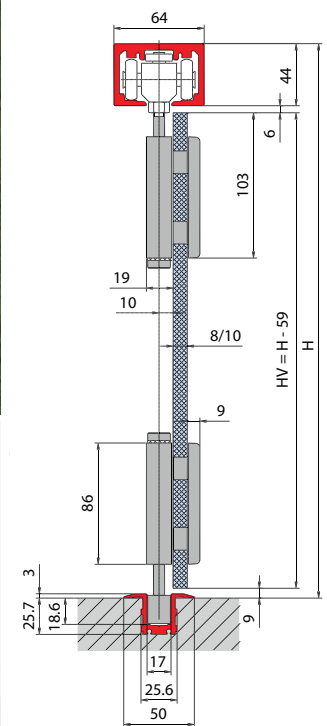

HV = H - 59



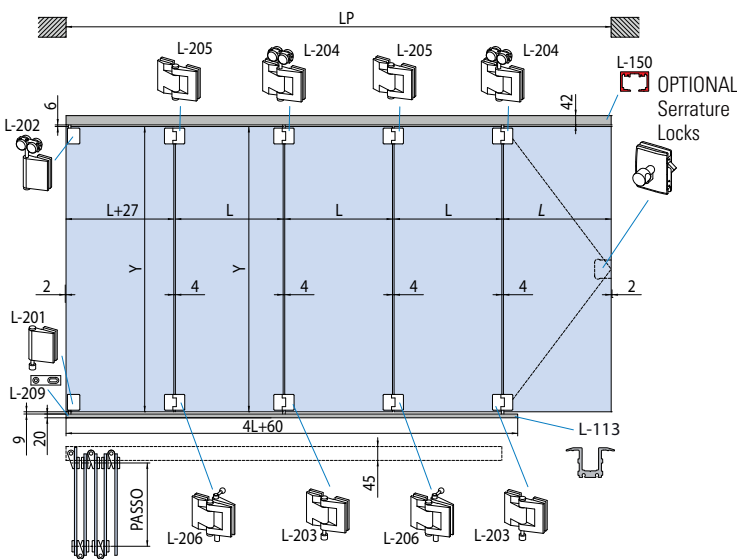
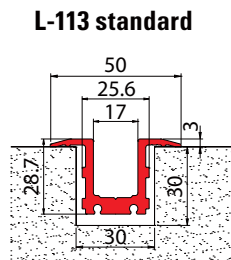
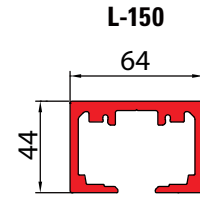
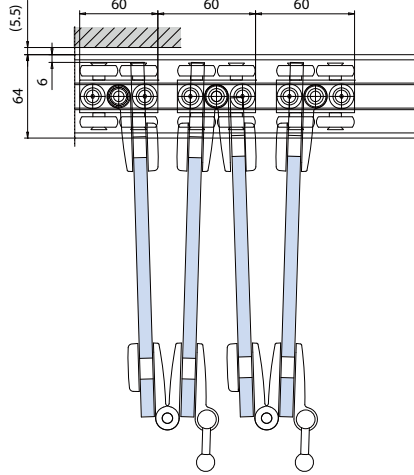
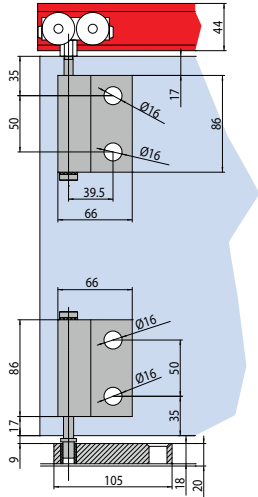
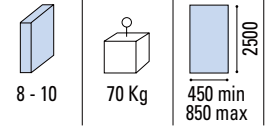
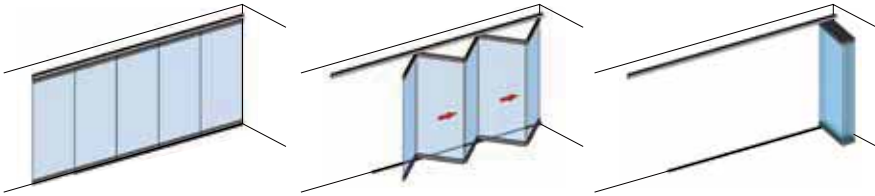

- Calcolo vetro
- Calculation glass
- Glasberechnung

N° ANTE PARI  
EVEN NO. PANELS  
GERADE FLÜGELANZAHL  
 $At = 4 \times N$   
 $X = LP - AT$   
 $L = (X - 54) / N$

N° ANTE DISPARI  
ODD NO. PANELS  
UNGERADE FLÜGELANZAHL  
 $At = 4 \times N$   
 $X = LP - AT$   
 $L = (X - 27) / N$

	L-1500 SET 1	(A)(D)
	L-1500 SET 2	(A)(B)(C)
	L-1500 SET 3	(A)(B)(B)(D)
	L-1500 SET 4	(A)(B)(B)(B)(C)
	L-1500 SET 5	(A)(B)(B)(B)(B)(D)

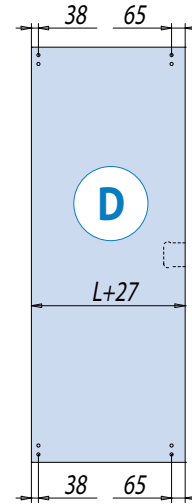
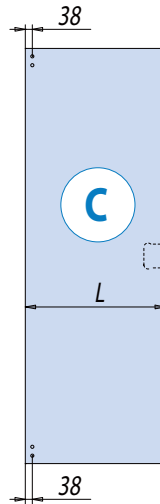
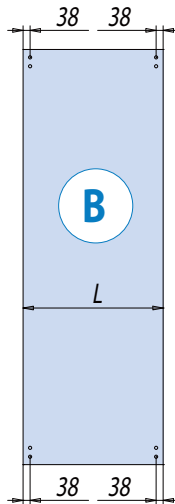
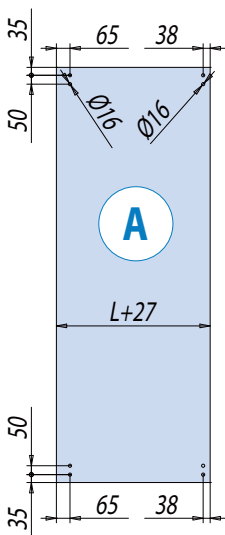

xla178 / xla226

AN	NS	At	N	LP	LA = LV	H	HV
Alluminio anodizzato Aluminium anodized Aluminium Silberfarbig	Nickel satinato Satin nickel Ähnlich Edelstahl matt	Arie totali Total clearances Summe alle Abstände Glas/Wand	Numero ante Numbers panels Anzahl der Elemente	Passaggio luce Clear opening width Lichte Durchgangsbreite	Larghezza ante = Larghezza vetro Panel width = Glass width Flügelbreite = Glasbreite	Altezza passaggio luce Clear opening height Lichte durchgangshöhe	Altezza vetro Glass height Glashöhe

## L-1000 LIBRO FOLDING

€ ▶ C.245

SCORREVOLI A LIBRO / SLIDING FOLDING SYSTEMS / FALT-SCHIEBEWANDSYSTEME



- Sistema scorrevole a libro con cerniere a vista e fori nel vetro, completo di binario standard h=75 mm x L=70 mm e carrello con 8 ruote.
- Sliding folding door system with visible hinges and holes in glass, including standard rail h=75 mm x L=70 mm and carriage with 8 wheels.
- Faltschiebewandssystem mit sichtbaren Bändern und Glasbohrungen, komplett mit Standard-Laufschiene h=75 mm x L=70 mm und Laufwagen mit 8 Rädern.

SCORREVOLI A LIBRO  
SLIDING FOLDING SYSTEMS

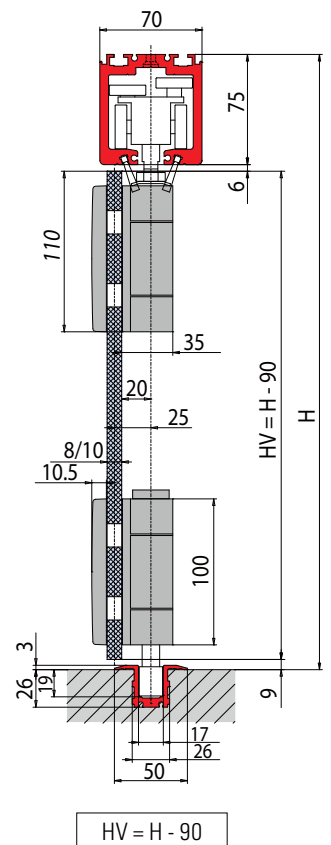

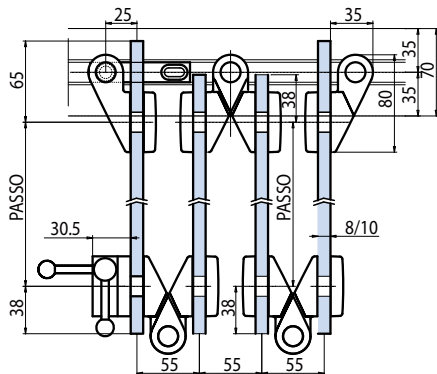
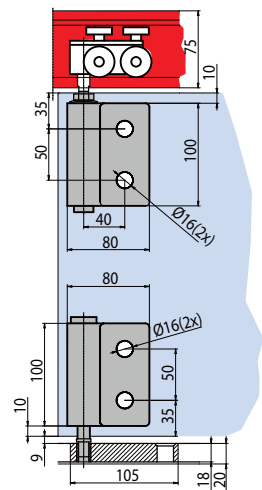
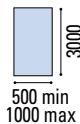
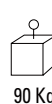
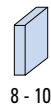
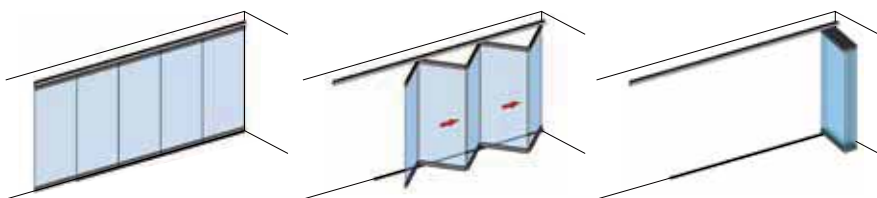

PA-100

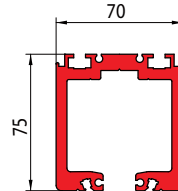

L-113 standard

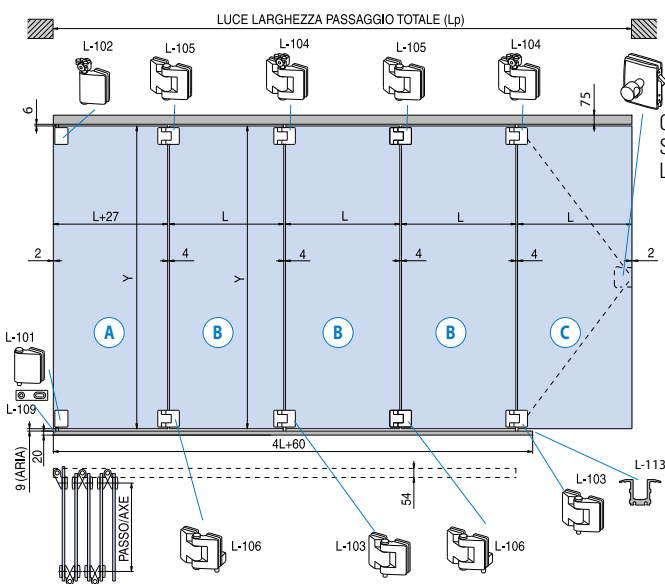
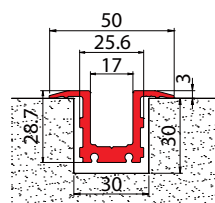

LUCE LARGHEZZA PASSAGGIO TOTALE (Lp)

OPTIONAL  
Serrature  
Locks

- Calcolo vetro
- Calculation glass
- Glasberechnung

N° ANTE PARI  
EVEN NO. PANELS  
GERADE FLÜGELANZAHL  
 $At = 4 \times N$   
 $X = LP - AT$   
 $L = (X - 54) / N$

N° ANTE DISPARI  
ODD NO. PANELS  
UNGERADE FLÜGELANZAHL  
 $At = 4 \times N$   
 $X = LP - AT$   
 $L = (X - 27) / N$

	L-1000 SET 1	(A D)
	L-1000 SET 2	(A B C)
	L-1000 SET 3	(A B B D)
	L-1000 SET 4	(A B B B C)
	L-1000 SET 5	(A B B B B D)

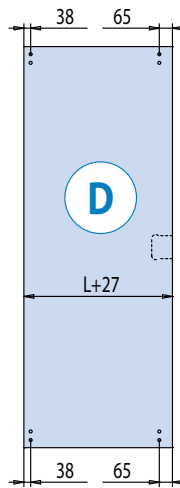
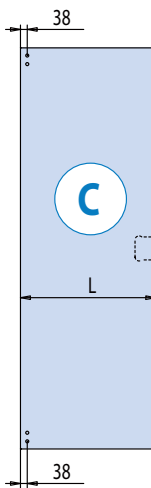
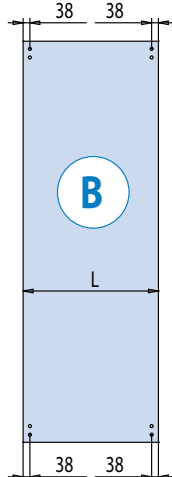
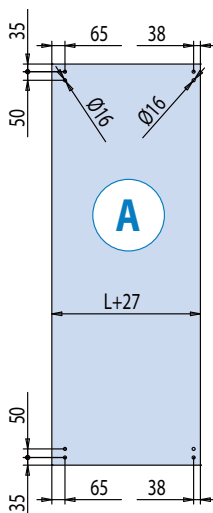

xla122-new / xla83-4 / xla122

AN	NS	At	N	LP	LA = LV	H	HV
Alluminio anodizzato Aluminium anodized Aluminium Silberfarbig	Nickel satinato Satin nickel Ähnlich Edelstahl matt	Arie totali Total clearances Summe alle Abstände	Numero ante Numbers panels Anzahl der Elemente	Passaggio luce Clear opening width Lichte Durchgangsbreite	Larghezza ante = Larghezza vetro Panel width = Glass width Flügelbreite = Glasbreite	Altezza passaggio luce Clear opening height Lichte durchgangshöhe	Altezza vetro Glass height Glashöhe

## L-1500 LIBRO FOLDING / L-2500 ▶ 116 COMPONENTI / COMPONENTS / EINZELTEILE

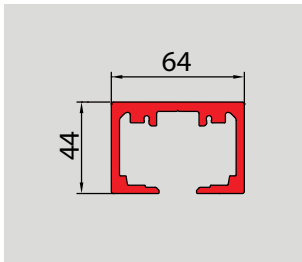

### L-150

- Binario superiore di scorrimento in alluminio per sistema L-2500 e L-1500
- Aluminium top track profile for system L-2500 and L-1500
- Aluminium Laufschienenprofil für System L-2500 und L-1500

€▶ C.231

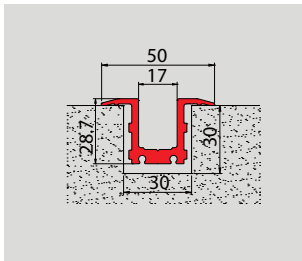

### L-113

- Canalina a terra in alluminio (standard già inclusa nel set)
- Floor channel, floor installation (standard included in folding set)
- Bodenführung mit Bodenvorbereitung (Standard im Set enthalten)

€▶ C.232

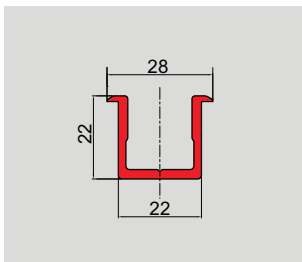

### L-110

- Guida a pavimento
- Bottom rail
- Bodenführung

€▶ C.233

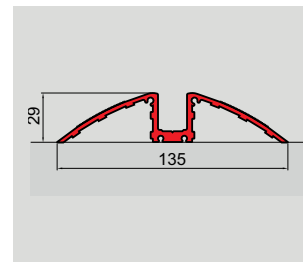

### L-115

- Guida a pavimento
- Bottom rail
- Bodenführung

€▶ C.234



### L-201

- Cerniera laterale inferiore per prima/ultima anta
- Bottom hinge fitting for first/last panel
- Unteres seitliches Band für erstes/letztes Element

€▶ C.235



### L-202

- Cerniera laterale superiore per prima/ultima anta
- Top hinge fitting for first/last panel
- Oberes seitliches Band für erstes/letztes Element

€▶ C.239



### L-203

- Cerniera inferiore di scorrimento per guida pavimento
- Bottom sliding hinge for bottom rail
- Unteres Faltband für Fußboden Führung

€▶ C.240

**L-204**

- Cerniera superiore di scorrimento in guida
- Top sliding hinge for the track profile
- Oberes Faltband mit Laufwagen für Laufschiene

€ ▶ C.241

**L-205**

- Cerniera centrale inferiore/superiore
- Top/bottom hinge
- Unteres/oberes Faltband

€ ▶ C.242

**L-206**

- Cerniera inferiore completa di catenacciolo di chiusura (per impacchettamento interno)
- Bottom hinge fitting with locking bolt (folding inside)
- Unteres Faltband mit unterer Verriegelung

€ ▶ C.243

**L-213**

- Cerniera fissaggio laterale per prima anta per sistema L-2500
- Hinge side fixing for first panel for system L-2500
- Band für erstes Element, Wandbefestigung für System L-2500

€ ▶ C.309

**L-214**

- Morsetto di sostegno centrale con carrello per sistema L-2500 - soffietto
- Suspension center clamp with trolley for system L-2500 - centerfolding
- Klemme mit Laufwagen für System L-2500 Faltsystem mit mittiger Faltung

€ ▶ C.310

**L-209**

- Pozzetto per cerniera inferiore prima/ultima anta
- Bottom pivot adaptor for first/last panel
- Bodenbuchse für erstes/letztes Element

€ ▶ C.244

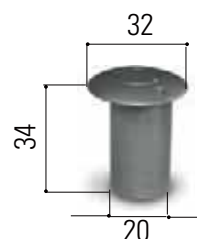
**L-112**

- Pozzetto inferiore eccentrico regolabile per perno
- Floor socket eccentric with adjustable insert
- Extenterbuchse verstellbar

€ ▶ C.07

# SCORREVOLI A SOFFIETTO

## SLIDING CENTER FOLDING

### FALT-SCHIEBEWANDSYSTEME

Senza guida a terra / Center folding sliding systems without floor rail / Falt-Schiebewandsysteme mit mittiger Faltung ohne Bodenführung

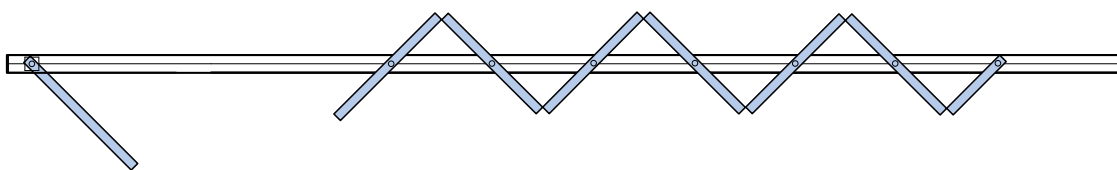

#### PA-260 CENTER FOLDING ▶ 102

- Sistema a soffietto con impacchettamento centrale fornito con profili a misura richiesta dal cliente, senza fori nel vetro né guida a terra, e completo di binario standard h=75 mm x L=70 mm e carrello con 8 ruote.
- Folding door system with center fold with profiles in sizes requested by the client, without holes in the glass and without bottom guide channel, and including rail h=75 mm x L=70 mm and carriage with 8 wheels.
- Faltschiebewandsystem mit mittiger Faltung, kundenspezifische Profile, ohne Glasbohrungen und Bodenführung, komplett mit Laufschiene h=75 mm x L=70 mm und Laufwagen mit 8 Rädern.

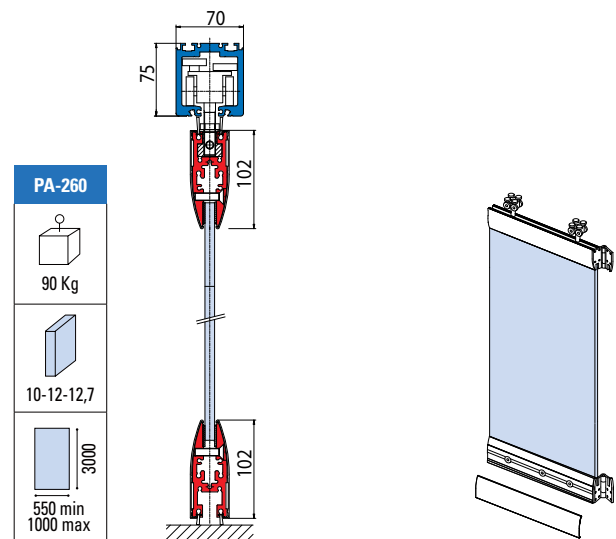

**PA-760 CENTER FOLDING** **do-it-yourself ▶ 106**
**PA-560 CENTER FOLDING** **do-it-yourself ▶ 112**

- Sistema a soffietto con profili fermavetro continui a misura standard (mm 1200) da tagliare secondo necessità a cura del cliente, completi di catenaccioli fermaanta a posizionamento esterno regolabile, binario standard h = 44 mm x L = 64 mm e carrello con 4 ruote. Vantaggi di una consegna più veloce e di un unico prodotto a magazzino per tutte le misure fino a 850 mm / 800 mm.
- Folding door system with center fold, with continuous glass fixing profiles of a standard size (mm 1200) to be cut on the basis of client's requirements, comes equipped with an adjustable door holding latch positioned externally, including standard rail h = 44 mm x L = 64 mm and carriage with 4 wheels. The advantage of this product is quick delivery and a unique product available in the warehouse for all sizes up to 850 mm / 800 mm.
- Faltschiebewandssystem mit zentraler Faltung mit durchgehenden Glasleistenprofilen in Standardgröße (1200 mm) ablängbar, komplett mit äußeren einstellbaren Riegeln zur Flügelfeststellung, Laufschiene h = 44 mm x L = 64 mm und Laufwagen mit 4 Rädern. Vorteile einer raschen Lieferung und eines einzigen lagermäßigen Produktes mit Abmessungen bis 850 mm / 800 mm.

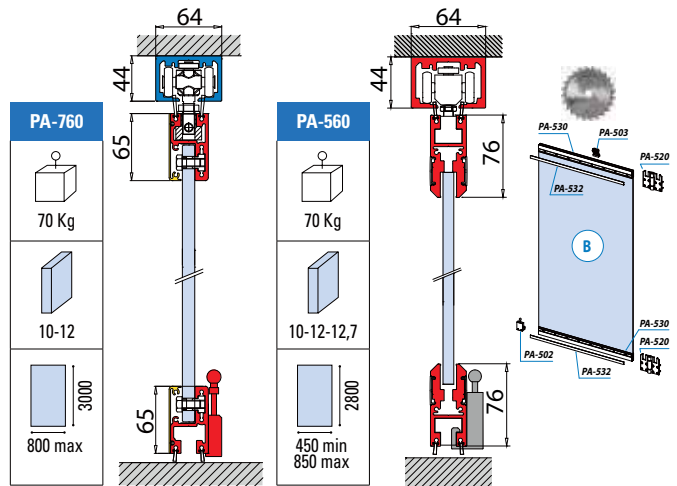
**PA-460 CENTER FOLDING** **do-it-yourself ▶ 110**

- Sistema modulare a soffietto con impacchettamento centrale completo di morsetti fermavetro (mm 250), veletta continua (mm 1200) da tagliare secondo necessità a cura del cliente, binario standard h=75 mm x L=70 mm e carrello con 8 ruote. Vantaggi di una consegna più veloce e di un unico prodotto a magazzino per tutte le misure fino a 1000 mm.
- Folding door system with center fold with glass fixing clamps (mm 250) and continuous covers (mm 1200) to be cut on the basis of client's requirements, and including standard rail standard h=75 mm x L=70 mm and carriage with 8 wheels. The advantage of this product is quick delivery and a unique product available in the warehouse for all sizes up to 1000 mm.
- Faltschiebewandssystem mit mittiger Faltung, Glashalteklammern (250 mm), kontinuierlicher Verkleidung (1200 mm) kundenspezifisch ablängbar, Standardlaufschiene h=75 mm x L=70 mm und Laufwagen mit 8 Rädern. Vorteile einer raschen Lieferung und eines einzigen lagermäßigen Produktes mit Abmessungen bis 1000 mm.

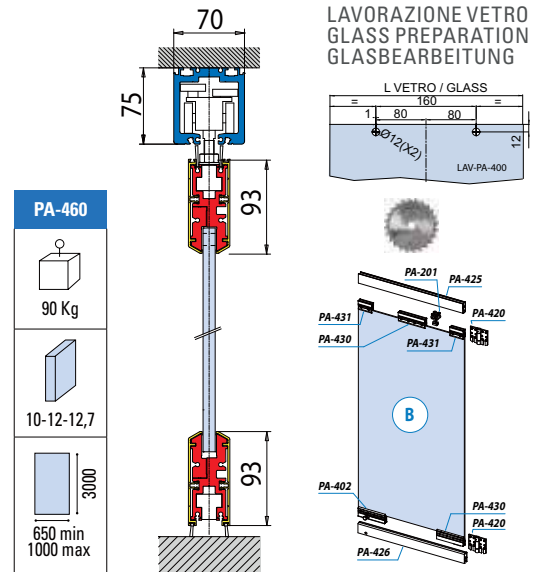
**LAVORAZIONE VETRO  
GLASS PREPARATION  
GLASBEARBEITUNG**
**L-2500 SOFFIETTO CENTER FOLDING ▶ 116**

- Sistema a soffietto con impacchettamento centrale, cerniere a vista e fori nel vetro, completo di binario standard h=44 mm x L=64 mm e carrello con 4 r.
- Center folding system, visible hinges and holes in glass, including rail h=44 mm x L=64 mm and carriage with 4 wheels.
- Faltschiebewandssystem mit mittiger Faltung, mit sichtbaren Bändern und Glasbohrungen, komplett mit Laufschiene h=44 mm x L=64 mm und Laufwagen mit 4 Rädern.

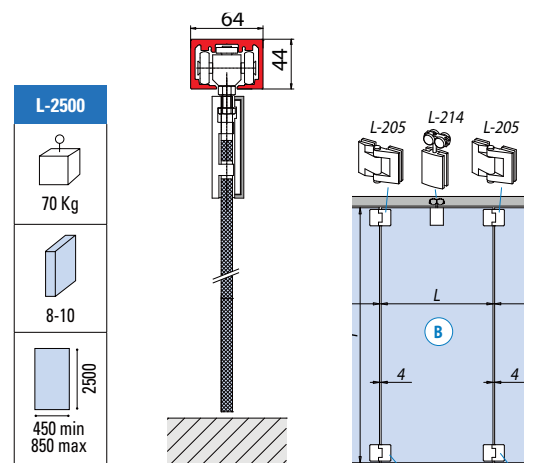

## PA-260 CENTER FOLDING

SCORREVOLI A SOFFIETTO / SLIDING CENTER FOLDING / FALT-SCHIEBEWANDSYSTEME

MY METALGLAS

€ ▶ C.261



- Sistema a soffietto con impacchettamento centrale fornito con profili a misura richiesta dal cliente, senza fori nel vetro né guida a terra, e completo di binario standard h=75 mm x L=70 mm e carrello con 8 ruote.
- Folding door system with center fold with profiles in sizes requested by the client, without holes in the glass and without bottom guide channel, and including rail h=75 mm x L=70 mm and carriage with 8 wheels.
- Faltschiebewandssystem mit mittiger Faltung, kundenspezifische Profile, ohne Glasbohrungen und Bodenführung, komplett mit Laufschiene h=75 mm x L=70 mm und Laufwagen mit 8 Rädern.

SCORREVOLI A SOFFIETTO  
SLIDING CENTER SYSTEMS

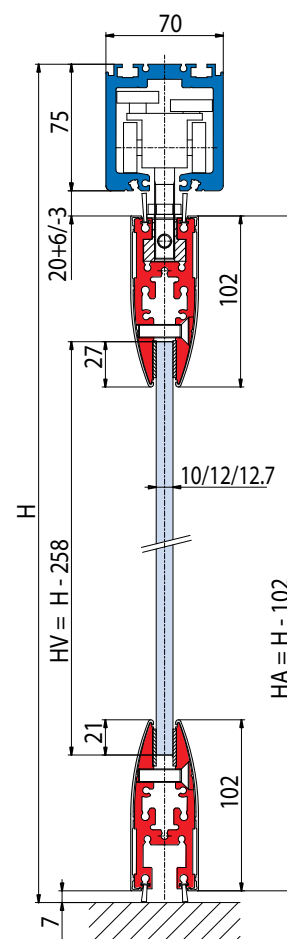

HV = H - 258  
HA = H - 102



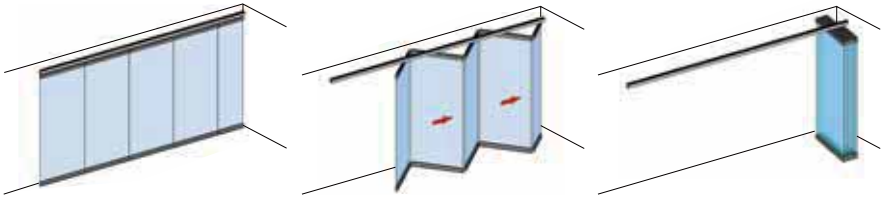

10-12-12,7	90 Kg	3000 550 min 1000 max
------------	-------	-----------------------------

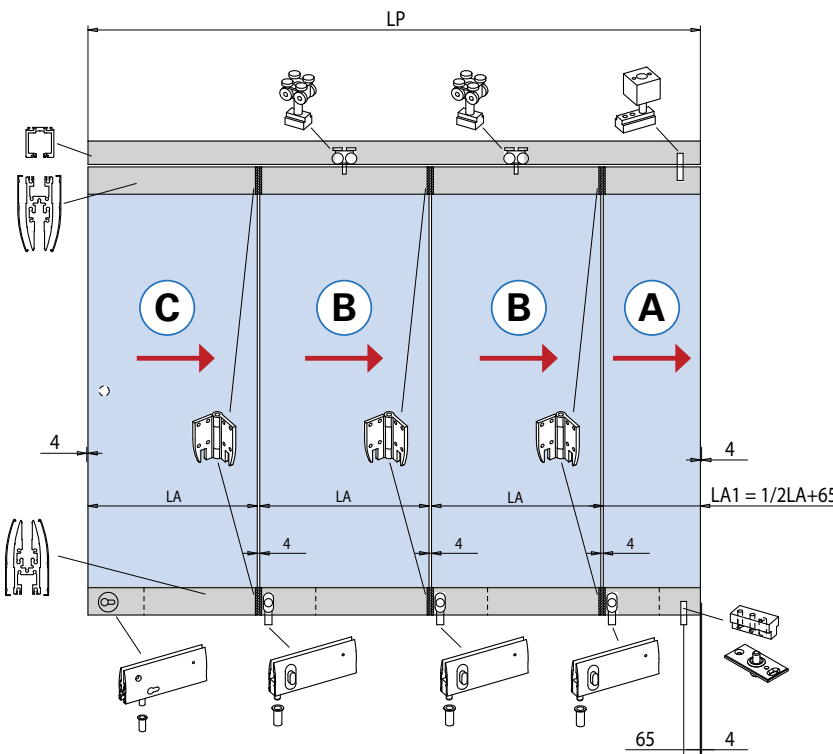
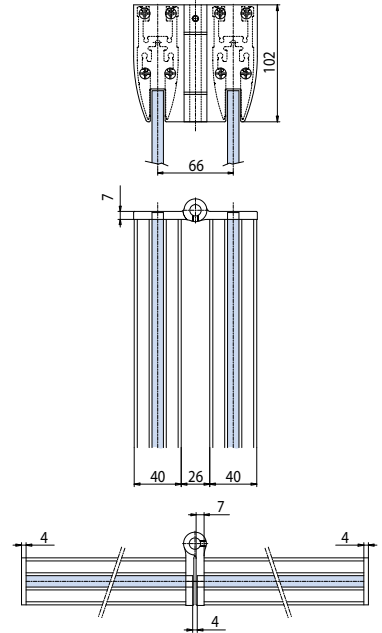
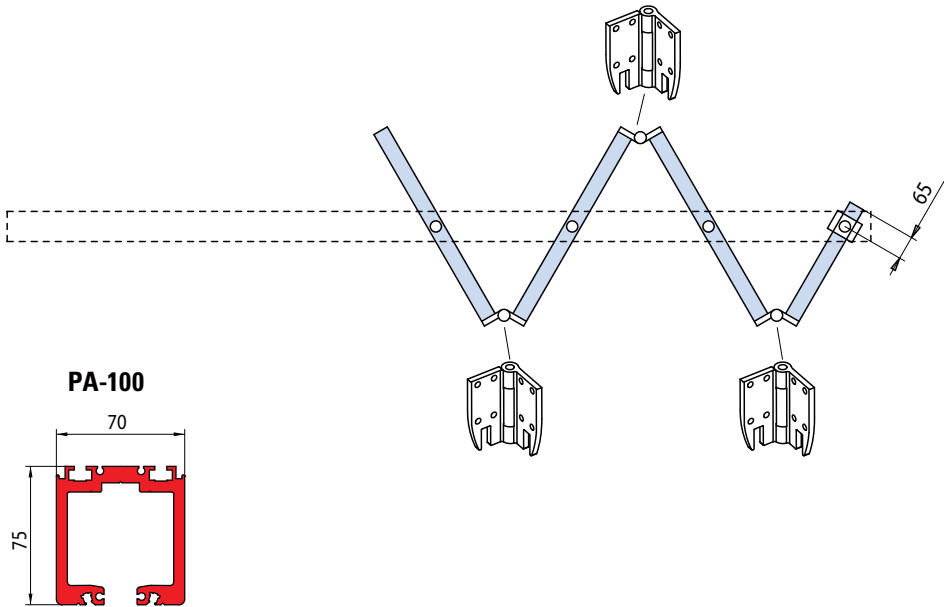

- Calcolo vetro
- Calculation glass
- Glasberechnung

At = 4 x (N + 1)  
X = LP - At  
LA = LV = (X - 65) / (N - 0,5)  
LA1 = LV1 = 1/2LA + 65

- (A)**
  - Prima anta a libro
  - First folding panel
  - Erster Faltelement
- (B)**
  - Anta intermedia a libro
  - Intermediate folding panel
  - Mittiges Faltelement
- (C)**
  - Ultima anta a libro
  - Last folding panel
  - Letzter Dreh-Schiebeflügel

	PA-260 SET 3
	PA-260 SET 4
	PA-260 SET 5
	PA-260 SET 6
	PA-260 SET 7
	PA-260 SET 8

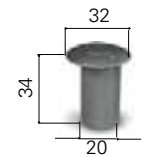

- L-112-PA**
  - For panel C
- L-112**
  - For panel A-B



SCORREVOLI A SOFFIETTO  
SLIDING CENTER SYSTEMS

xla173 / xme295 / xla176b

AN	NS	At	N	LP	LA = LV	H	HV
Alluminio anodizzato	Nickel satinato	Arie totali	Numero ante	Passaggio luce	Larghezza ante = Larghezza vetro	Altezza passaggio luce	Altezza vetro
Aluminium anodized	Satin nickel	Total clearances	Numbers panels	Clear opening width	Panel width = Glass width	Clear opening height	Glass height
Aluminium Silberfarbig	Ähnlich Edelstahl matt	Summe alle Abstände Glas/Wand	Anzahl der Elemente	Lichte Durchgangsbreite	Flügelbreite = Glasbreite	Lichte durchgangshöhe	Glashöhe

# PA-260 CENTER FOLDING

**COME USARE MY METALGLAS / HOW TO USE MY METALGLAS / WIE MAN BENUTZT MY METALGLAS**

**1** INSERIRE LE MISURE DEL TUO VANO E LE ANTE DESIDERATE  
ENTER THE MEASUREMENTS OF YOUR OPENING AND THE DOORS YOU REQUIRE  
GEBEN SIE DIE MASSE IHRER ÖFFNUNG EIN UND DIE ERFORDERLICHEN TÜREN

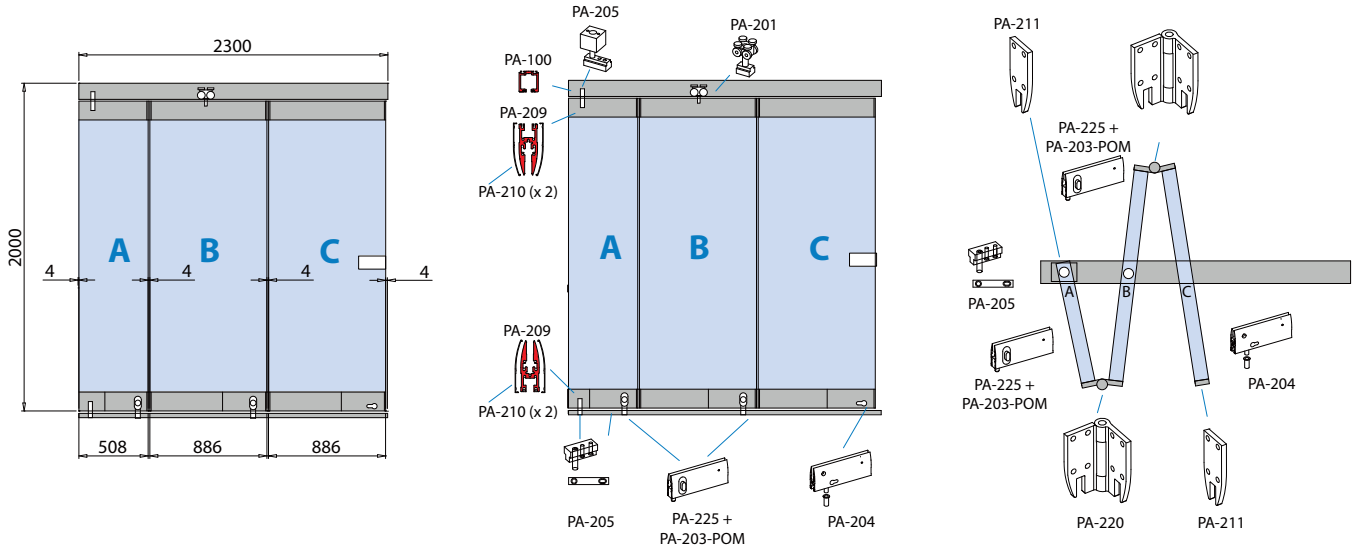

**2** SI OTTENGONO LE MISURE DEI VETRI AUTOMATICAMENTE  
THE MEASUREMENTS OF THE GLASS WILL BE GENERATED AUTOMATICALLY  
DIE ABMESSUNGEN DES GLASES WERDEN AUTOMATISCH BERECHNET

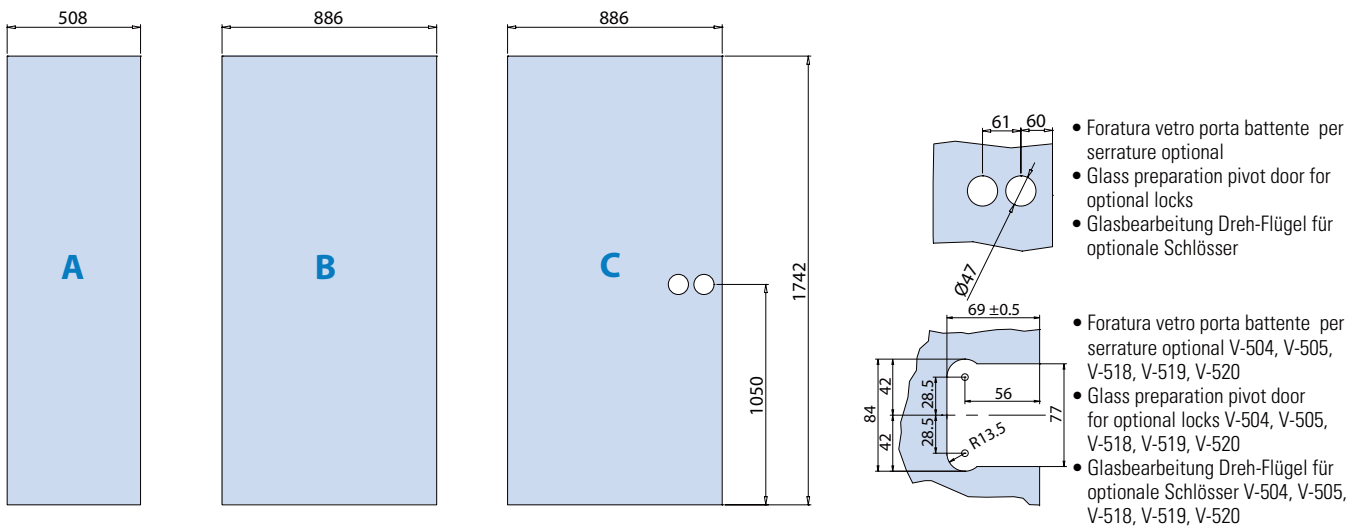

**3** SI OTTENGONO LE DISTINTE DI TAGLIO DEI PROFILI, DA ABBINARE AGLI ACCESSORI  
THE CUTTING SPECIFICATIONS OF THE PROFILES ARE OBTAINED, FOR MATCHING WITH THE ACCESSORIES  
SIE ERHALTEN EINE SPEZIFIKATION DER PROFILLÄNGEN ZUM ABGLEICHEN MIT DEM ZUBEHÖR

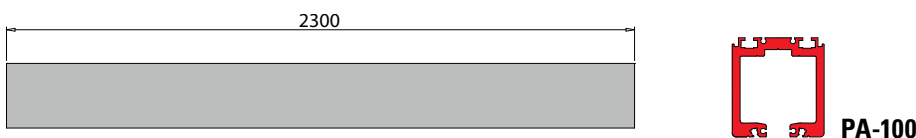

SCORREVOLI A SOFFIETTO  
SLIDING CENTER SYSTEMS

# PA-260 CENTER FOLDING

## COME ASSEMBLARE LE ANTE / HOW TO ASSEMBLE THE DOORS / WIE DIE TÜREN ZUSAMMENSETZT WERDEN

TAGLIO PROFILI PROFIL PREPARATION / PROFILBEARBEITUNG		KIT ACCESSORI ACCESSORY SETS / ZUBEHÖR SETS		ANTA COMPLETA COMPLETE DOOR / KOMPLETTE TÜR
--	--	--	--	--

**ANTA A / DOOR A / TÜRA**

PA-209 (x 2)  
PA-210 (x 4)

**SUPERIORE / TOP / OBEN**  
497

102

**INFERIORE / BOTTOM / UNTEN**  
497

247 250

102

PA-209 PA-225 + PA-203-POM

- Lavorazione veletta  
PA-210 con PA-225 + PA-203-POM
- Cover profile preparation  
PA-210 with PA-225 + PA-203-POM
- Vorbereitung der Abdeckung  
PA-210 mit PA-225 + PA-203-POM

**PA-260 ANTA A-10** (for glass 10 mm)  
**PA-260 ANTA A-12** (for glass 12 - 12,7 mm)  
PRIMA ANTA A LIBRO A  
FIRST FOLDING PANEL A  
ERSTER FALTELEMENT A

**ANTA B / DOOR B / TÜRB**

PA-209 (x 2)  
PA-210 (x 4)

**SUPERIORE / TOP / OBEN**  
872

102

**INFERIORE / BOTTOM / UNTEN**  
872

622 250

102

PA-209 PA-225 + PA-203-POM

- Lavorazione veletta  
PA-210 con PA-225 + PA-203-POM
- Cover profile preparation  
PA-210 with PA-225 + PA-203-POM
- Vorbereitung der Abdeckung  
PA-210 mit PA-225 + PA-203-POM

**PA-260 ANTA B-10** (for glass 10 mm)  
**PA-260 ANTA B-12** (for glass 12 - 12,7 mm)  
ANTA INTERMEDIA A LIBRO B  
MIDDLE FOLDING PANEL B  
MITTIGES FALTELEMENT B

**ANTA C / DOOR C / TÜRC**

PA-209 (x 2)  
PA-210 (x 4)

**SUPERIORE / TOP / OBEN**  
875

102

**INFERIORE / BOTTOM / UNTEN**  
875

250

102

PA-209 PA-204

**PA-260 ANTA C-10** (for glass 10 mm)  
**PA-260 ANTA C-12** (for glass 12 - 12,7 mm)  
PORTA LATERALE A LIBRO C  
LATERAL FOLDING PANEL C  
DREH-SCHIEBEFLÜGEL C

SCORREVOLI A SOFFIETTO  
SLIDING CENTER SYSTEMS

# PA-760 CENTER FOLDING do-it-yourself

SCORREVOLI A SOFFIETTO / SLIDING CENTER FOLDING / FALT-SCHIEBEWANDSYSTEME

MY METALGLAS





€ C.272

NEW



- Sistema a soffietto con profili fermavetro continui a misura standard (mm 1000) da tagliare secondo necessità a cura del cliente, completi di catenaccioli ferma-anta a posizionamento esterno regolabile, binario h=44 mm x L=64 mm e carrello con 4 ruote. Vantaggi di una consegna più veloce e di un unico prodotto a magazzino per tutte le misure fino a 800 mm.
- Folding door system with center fold, with continuous glass fixing profiles of a standard size (mm 1000) to be cut on the basis of client's requirements, comes equipped with an adjustable door holding latch positioned externally, including rail h=44 mm x L=64 mm and carriage with 4 wheels. The advantage of this product is quick delivery and a unique product available in the warehouse for all sizes up to 800 mm.
- Faltschiebewandssystem mit zentraler Faltung mit durchgehenden Glasleistenprofilen in Standardgröße (1000 mm) ablängbar, komplett mit äußeren einstellbaren Riegeln zur Flügelfeststellung, Laufschiene h=44 mm x L=64 mm und Laufwagen mit 4 Rädern. Vorteile einer raschen Lieferung und eines einzigen lagermäßigen Produktes mit Abmessungen bis 800 mm.

SCORREVOLI A SOFFIETTO  
SLIDING CENTRE SYSTEMS

-  PA-760 SET 2 (A)(B)(C)
-  PA-760 SET 3 (A)(B)(B)(C)
-  PA-760 SET 4 (A)(B)(B)(B)(C)
-  PA-760 SET 5 (A)(B)(B)(B)(B)(C)

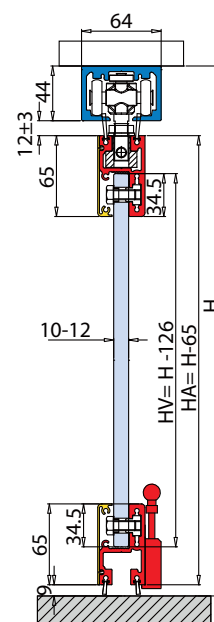

HV = H - 126

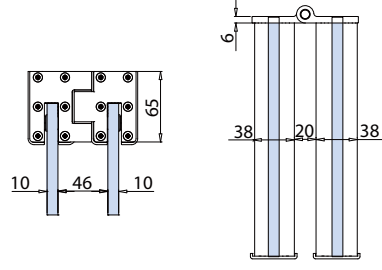
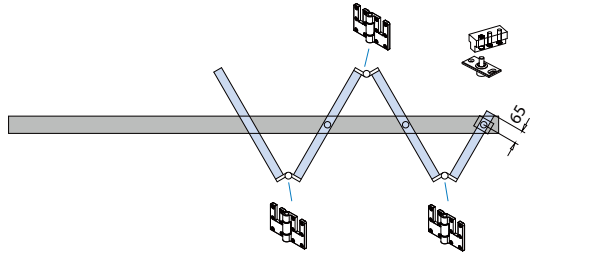
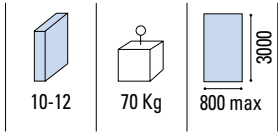
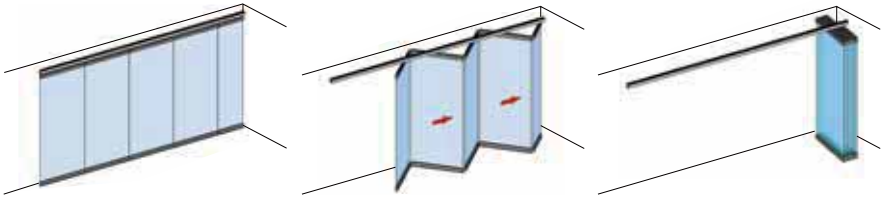

Anta libro / Folding panel/ Faltflügel     Anta libro / Folding panel/ Faltflügel

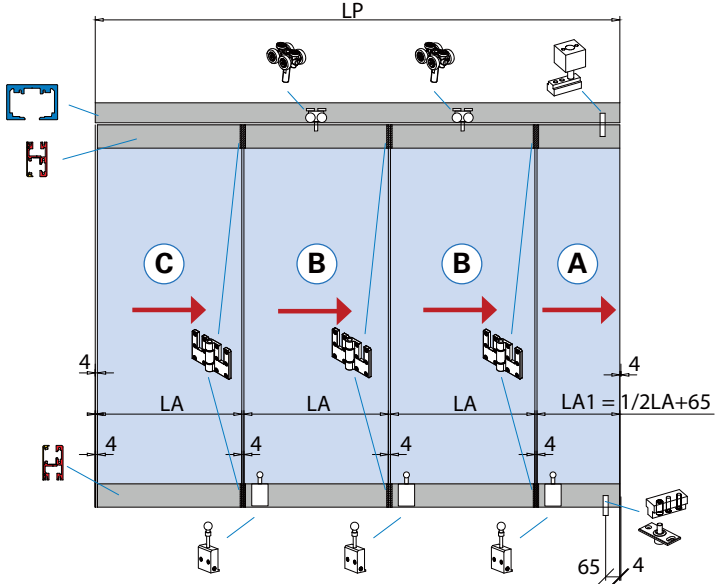
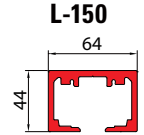
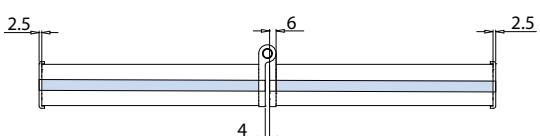
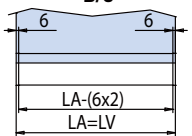
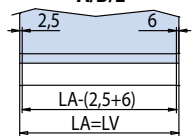

- Calcolo vetro
- Calculation glass
- Glasberechnung

At = 4 x (N + 1)  
 X = Lp - At  
 LA = LV = (X - 65) / (N-0,5)  
 LA1 = LV1 = 1/2LA + 65

LAVORAZIONE VETRO  
 GLASS PREPARATION  
 GLASBEARBEITUNG

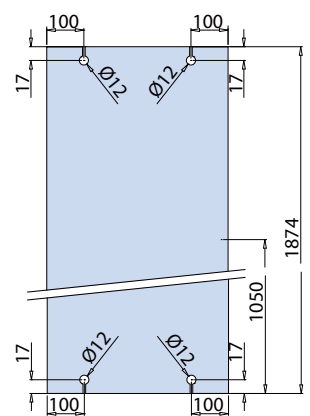

- A**
  - Prima anta a libro
  - First folding panel
  - Erster Faltelement
- B**
  - Anta intermedia a libro
  - Intermediate folding panel
  - Mittiges Faltelement
- C**
  - Ultima anta a libro
  - Last folding panel
  - Letzter Flügel

SCORREVOLI A SOFFIETTO  
 SLIDING CENTRE SYSTEMS

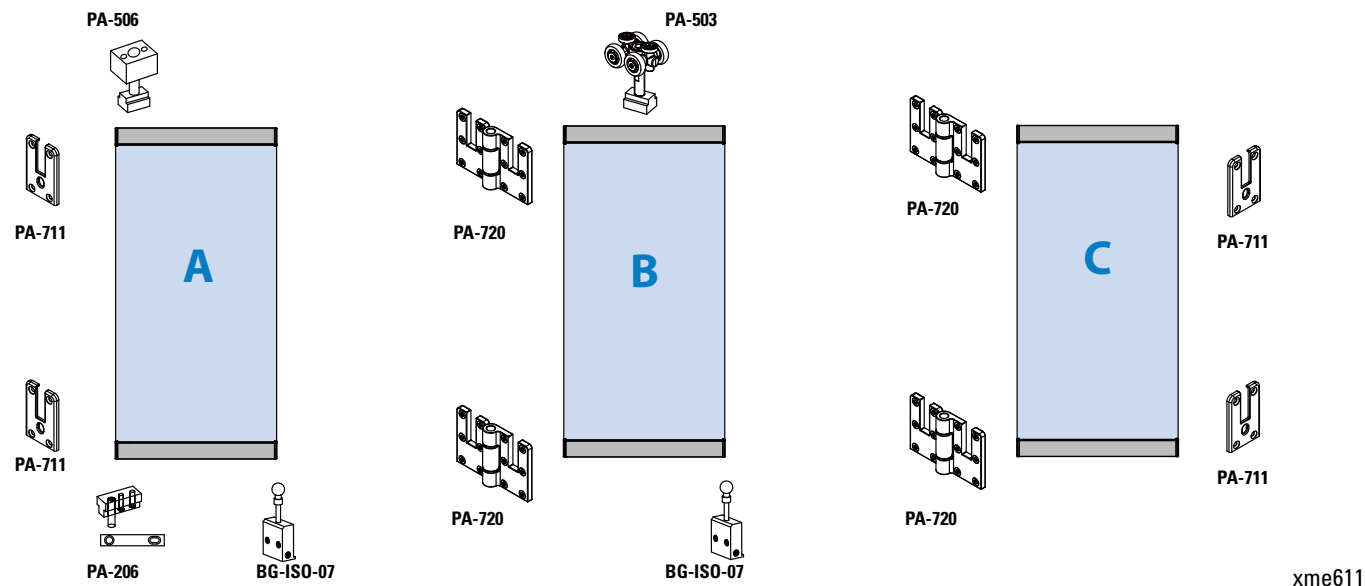

AN	At	N	LP	LA = LV	H	HV	HA
Alluminio anodizzato	Arie totali	Numero ante	Passaggio luce	Larghezza ante = Larghezza vetro	Altezza passaggio luce	Altezza vetro	Altezza anta
Aluminium anodized	Total clearances	Numbers panels	Clear opening width	Panel width = Glass width	Clear opening height	Clear opening height	Door height
Aluminium Silberfarbig	Summe alle Abstände Glas/Wand	Anzahl der Elemente	Lichte Durchgangsbreite	Flügelbreite = Glasbreite	Lichte durchgangshöhe	Glashöhe	Tür Höhe

xme611

# PA-760 CENTRAL FOLDING do-it-yourself

COME USARE **MY METALGLAS** / HOW TO USE **MY METALGLAS** / WIE MAN BENUTZT **MY METALGLAS**

**1** INSERIRE LE MISURE DEL TUO VANO E LE ANTE DESIDERATE  
ENTER THE MEASUREMENTS OF YOUR OPENING AND THE DOORS YOU REQUIRE  
GEBEN SIE DIE MASSE IHRER ÖFFNUNG EIN UND DIE ERFORDERLICHEN TÜREN

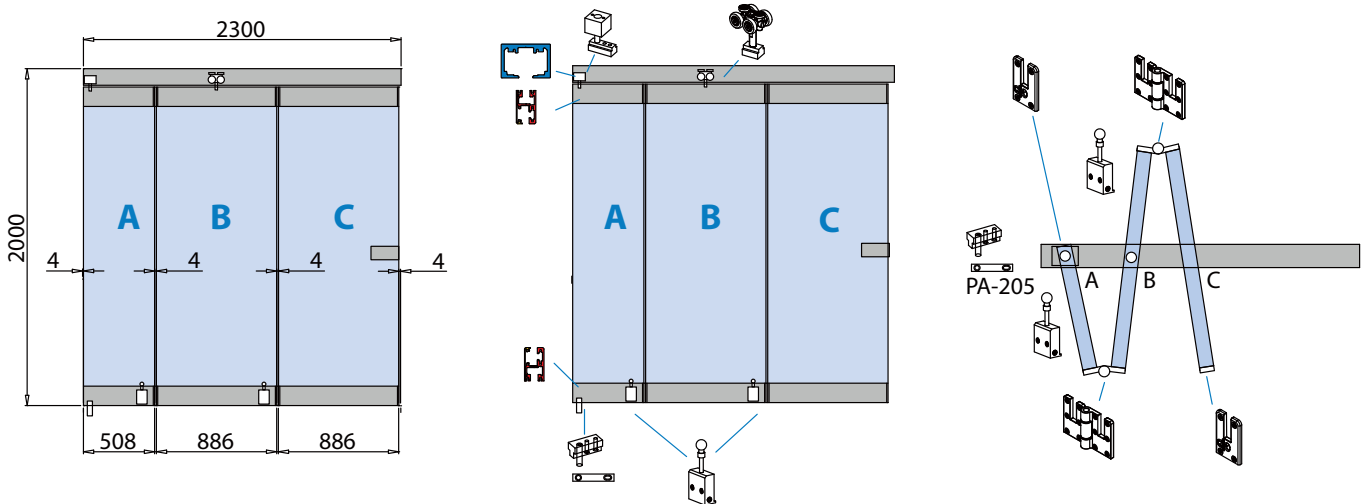

**2** SI OTTENGONO LE MISURE DEI VETRI AUTOMATICAMENTE  
THE MEASUREMENTS OF THE GLASS WILL BE GENERATED AUTOMATICALLY  
DIE ABMESSUNGEN DES GLASES WERDEN AUTOMATISCH BERECHNET

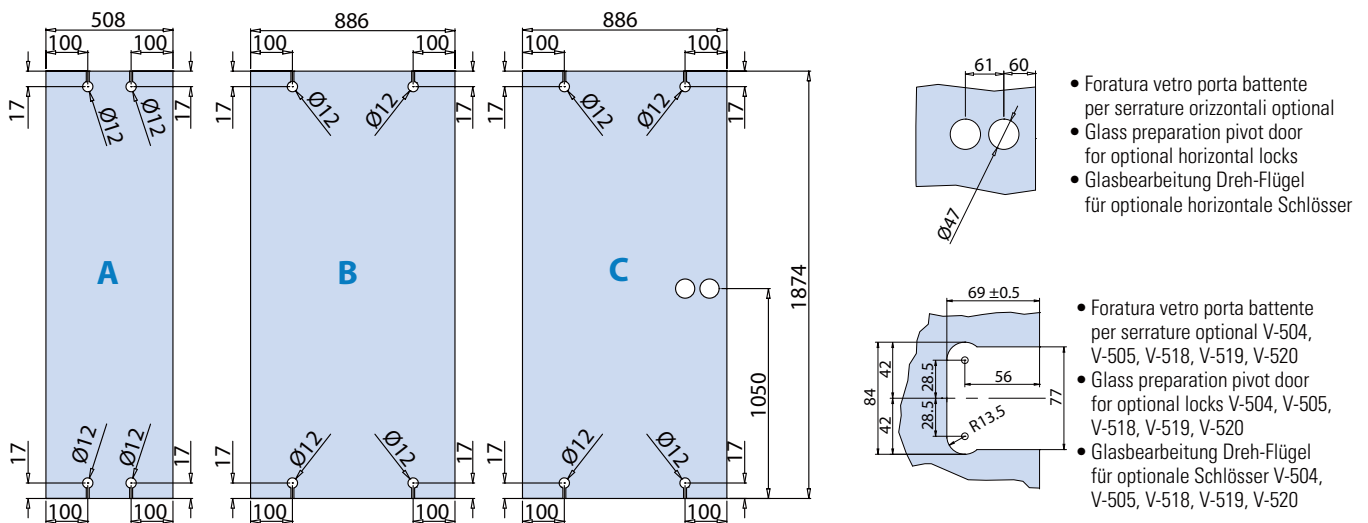

**3** SI OTTENGONO LE DISTINTE DI TAGLIO DEI PROFILI, DA ABBINARE AGLI ACCESSORI  
THE CUTTING SPECIFICATIONS OF THE PROFILES ARE OBTAINED, FOR MATCHING WITH THE ACCESSORIES  
SIE ERHALTEN EINE SPEZIFIKATION DER PROFILLÄNGEN ZUM ABGLEICHEN MIT DEM ZUBEHÖR

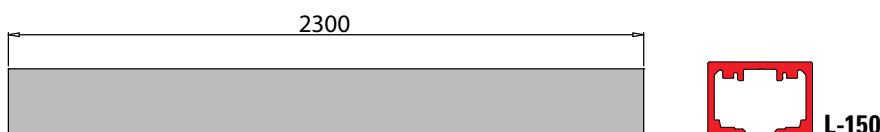

	PA-760 SET 2 (A)(B)(C)
	PA-760 SET 3 (A)(B)(B)(C)
	PA-760 SET 4 (A)(B)(B)(B)(C)
	PA-760 SET 5 (A)(B)(B)(B)(B)(C)

SCORREVOLI A SOFFIETTO  
SLIDING CENTRE SYSTEMS

# PA-760 CENTRAL FOLDING do-it-yourself

COME ASSEMBLARE LE ANTE / HOW TO ASSEMBLE THE DOORS / WIE DIE TÜREN ZUSAMMENSETZT WERDEN

TAGLIO PROFILI  
PROFIL PREPARATION / PROFILBEARBEITUNG



KIT ACCESSORI  
ACCESSORY SETS / ZUBEHÖR SETS



ANTA COMPLETA  
COMPLETE DOOR / KOMPLETTE TÜR

ANTA A / DOOR A / TÜRA

PA-730 (x 2)



SUPERIORE / TOP / OBEN

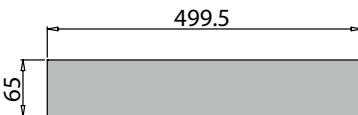

INFERIORE / BOTTOM / UNTEN

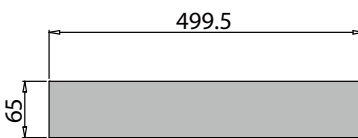

**PA-760 ANTA A** (for glass 10 / 12 mm)  
PRIMA ANTA A LIBRO A  
FIRST FOLDING PANEL A  
ERSTER FalTELEMENT A

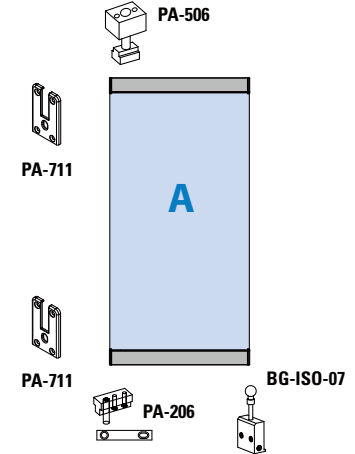
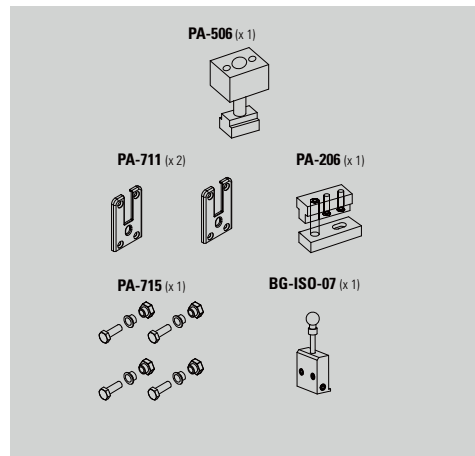

ANTA B / DOOR B / TÜRB

PA-730 (x 2)



SUPERIORE / TOP / OBEN

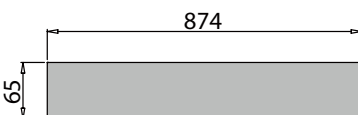

INFERIORE / BOTTOM / UNTEN

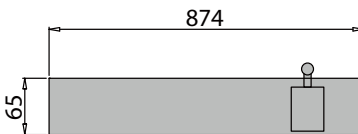

**PA-760 ANTA B** (for glass 10 / 12 mm)  
ANTA INTERMEDIA A LIBRO B  
MIDDLE FOLDING PANEL B  
MITTIGES FalTELEMENT B

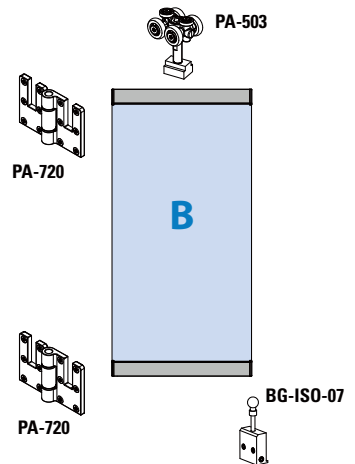
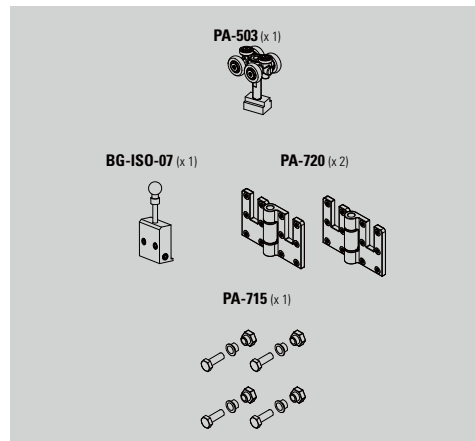

ANTA C / DOOR C / TÜRC

PA-730 (x 2)



SUPERIORE / TOP / OBEN

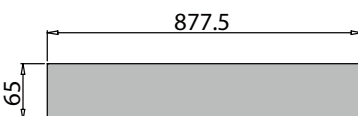

INFERIORE / BOTTOM / UNTEN

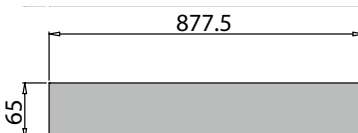

**PA-760 ANTA C** (for glass 10 / 12 mm)  
ULTIMA ANTA A LIBRO C  
LAST FOLDING PANEL C  
LETZTER FLÜGEL C

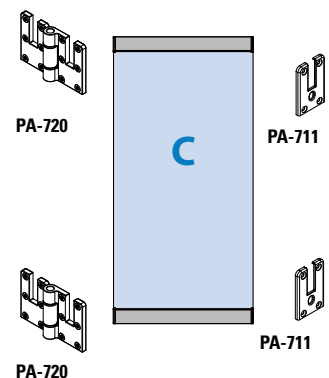
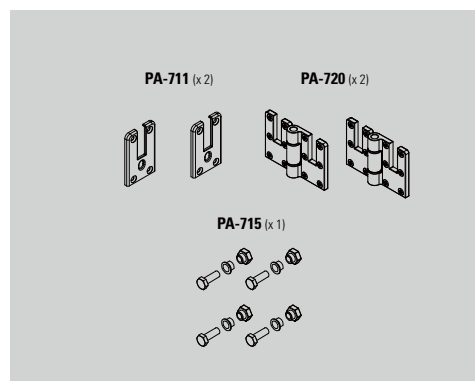

SCORREVOLI A SOFFIETTO  
SLIDING CENTRE SYSTEMS

# PA-460 CENTER FOLDING do-it-yourself

€ C.281





SCORREVOLI A SOFFIETTO / SLIDING CENTER FOLDING / FALT-SCHIEBEWANDSYSTEME

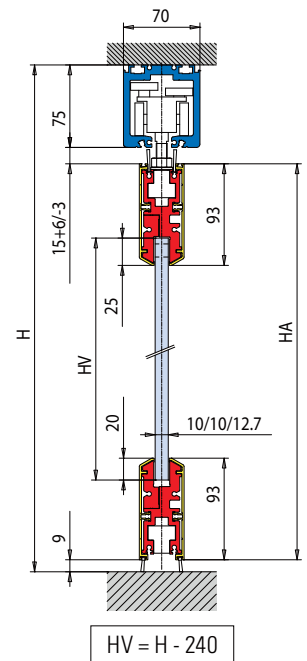

- Sistema modulare a soffietto con impacchettamento centrale completo di morsetti fermavetro (mm 250), veletta continua (mm 1200) da tagliare secondo necessità a cura del cliente, binario standard h=75 mm x L=70 mm e carrello con 8 ruote.
- Folding door system with center fold with glass fixing clamps (mm 250) and continuous covers (mm 1200) to be cut on the basis of client's requirements, and including standard rail standard h=75 mm x L=70 mm and carriage with 8 wheels.
- Faltschiebewandssystem mit mittlerer Faltung, Glashalteklappen(250 mm), kontinuierlicher Verkleidung (1200 mm) kundenspezifisch ablängbar, Standardlaufschiene h=75 mm x L=70 mm und Laufwagen mit 8 Rädern.



SCORREVOLI A SOFFIETTO  
SLIDING CENTER SYSTEMS

	PA-460 SET 2 (A)(B)(C)
	PA-460 SET 3 (A)(B)(B)(C)
	PA-460 SET 4 (A)(B)(B)(B)(C)
	PA-460 SET 5 (A)(B)(B)(B)(B)(C)

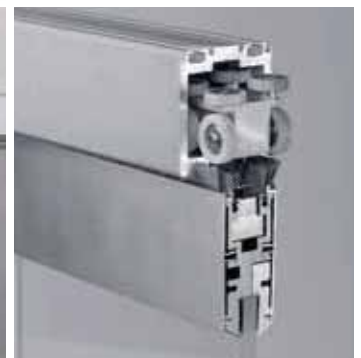



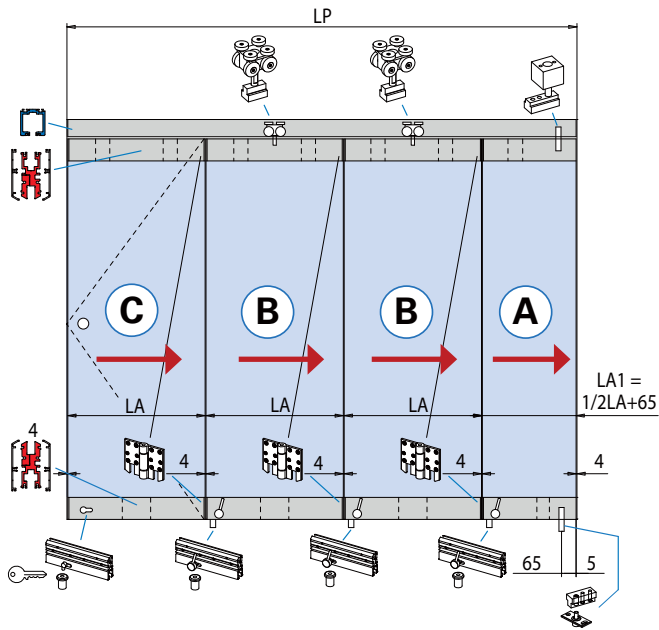
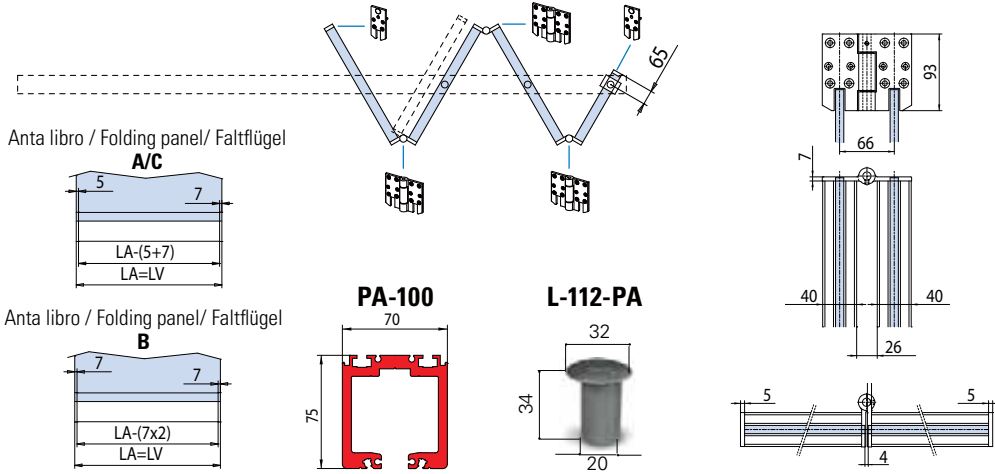
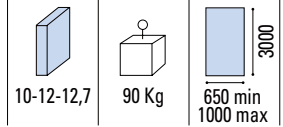
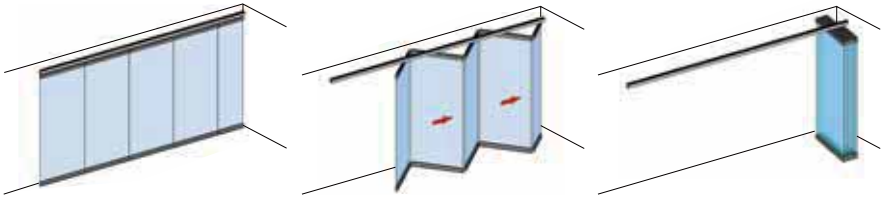

- Calcolo vetro
- Calculation glass
- Glasberechnung

$$At = 4 \times (N + 1)$$

$$X = Lp - At$$

$$LA = LV = (X - 65) / (N - 0,5)$$

$$LA1 = LV1 = \frac{1}{2}LA + 65$$

- A**
- Prima anta a libro
  - First folding panel
  - Erster Faltelement
- B**
- Anta intermedia a libro
  - Intermediate folding panel
  - Mittiges Faltelement
- C**
- Ultima anta a libro
  - Last folding panel
  - Letzter Flügel

LAVORAZIONE VETRO  
GLASS PREPARATION  
GLASBEARBEITUNG

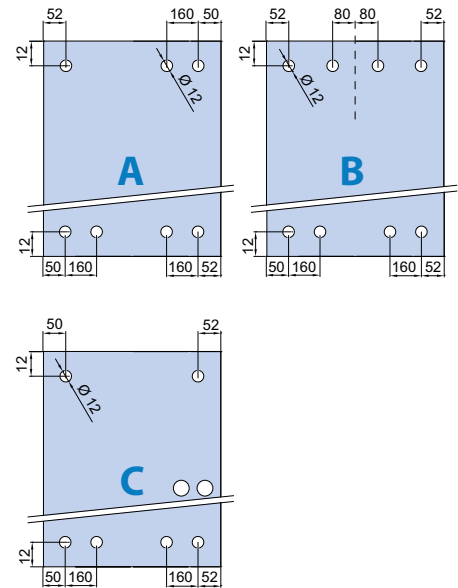

SCORREVOLI A SOFFIETTO  
SLIDING CENTER SYSTEMS

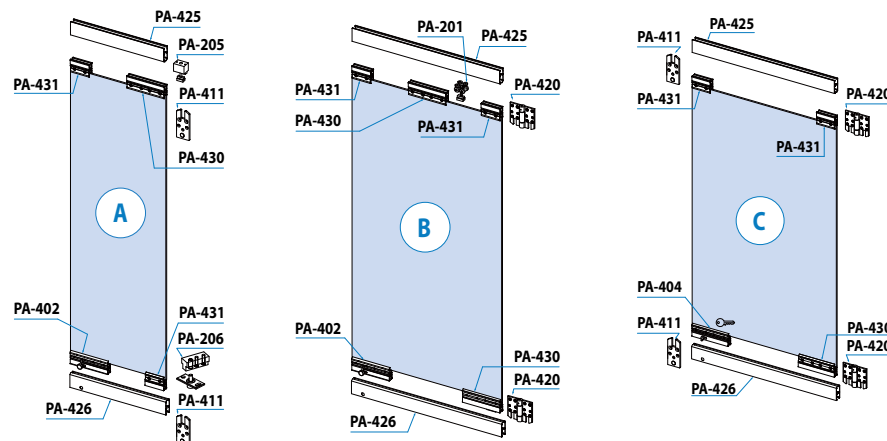

- C**
- Ultima anta a porta battente
  - Last folding swing door
  - Letzter Flügel als Dreh-Falt-Flügel

xla334-1 / xla334h / xla334e

AN	At	N	LP	LA = LV	H	HV	HA
Alluminio anodizzato Aluminium anodized Aluminium Silberfarbig	Arie totali Total clearances Summe alle Abstände Glas/Wand	Numero ante Numbers panels Anzahl der Elemente	Passaggio luce Clear opening width Lichte Durchgangsbreite	Larghezza ante = Larghezza vetro Panel width = Glass width Flügelbreite = Glasbreite	Altezza passaggio luce Clear opening height Lichte durchgangshöhe	Altezza vetro Glass height Glashöhe	Altezza anta Door height Tür Höhe

## PA-560 CENTER FOLDING do-it-yourself

SCORREVOLI A SOFFIETTO / SLIDING CENTER FOLDING / FALT-SCHIEBEWANDSYSTEME

MY METALGLAS

€ C.291



- Sistema a soffietto con profili fermavetro continui a misura standard (mm 1000) da tagliare secondo necessità a cura del cliente, completi di catenaccioli ferma-anta a posizionamento esterno regolabile, binario h=44 mm x L=64 mm e carrello con 4 ruote. Vantaggi di una consegna più veloce e di un unico prodotto a magazzino per tutte le misure fino a 850 mm.
- Folding door system with center fold, with continuous glass fixing profiles of a standard size (mm 1000) to be cut on the basis of client's requirements, comes equipped with an adjustable door holding latch positioned externally, including rail h=44 mm x L=64 mm and carriage with 4 wheels. The advantage of this product is quick delivery and a unique product available in the warehouse for all sizes up to 850 mm.
- Faltschiebewandssystem mit zentraler Faltung mit durchgehenden Glasleistenprofilen in Standardgröße (1000 mm) ablängbar, komplett mit äußeren einstellbaren Riegeln zur Flügelfeststellung, Laufschiene h=44 mm x L=64 mm und Laufwagen mit 4 Rädern. Vorteile einer raschen Lieferung und eines einzigen lagermäßigen Produktes mit Abmessungen bis 850 mm.

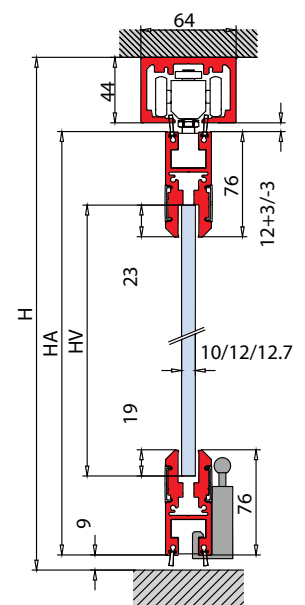

$$HV = H - 176$$



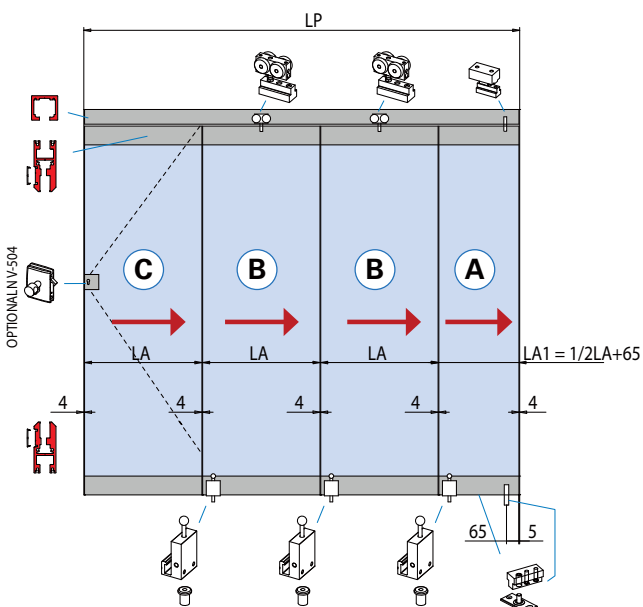
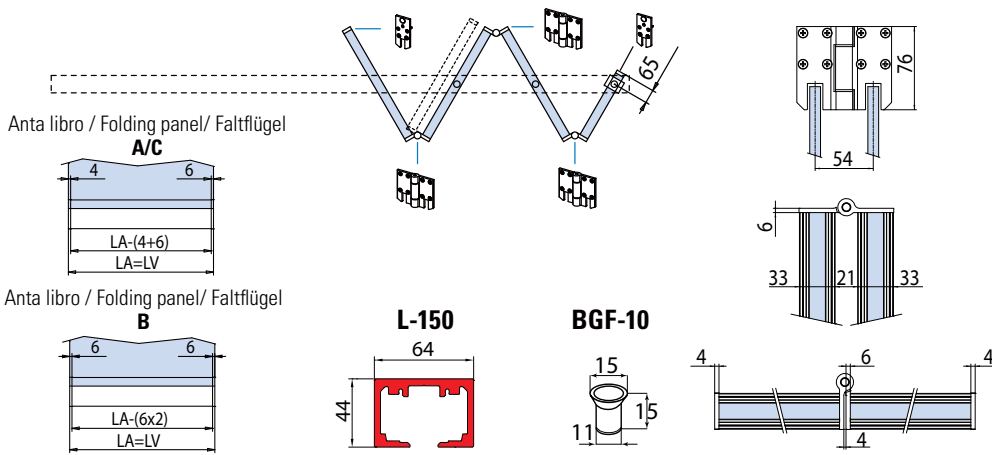
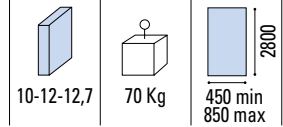
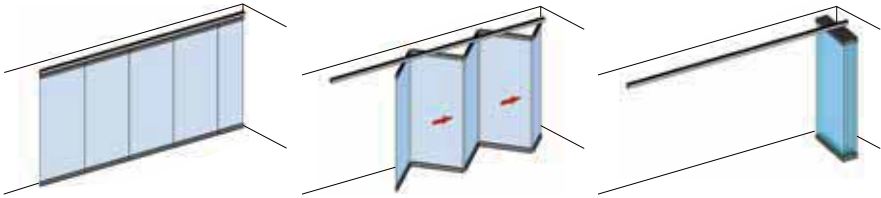

- Calcolo vetro
- Calculation glass
- Glasberechnung

$At = 4 \times (N + 1)$   
 $X = Lp - At$   
 $LA = LV = (X - 65) / (N - 0,5)$   
 $LA1 = LV1 = \frac{1}{2}LA + 65$

	PA-560 SET 2 (A)(B)(C)
	PA-560 SET 3 (A)(B)(B)(C)
	PA-560 SET 4 (A)(B)(B)(B)(C)
	PA-560 SET 5 (A)(B)(B)(B)(B)(C)

- (A)**
- Prima anta a libro
  - First folding panel
  - Erster Faltelement
- (B)**
- Anta intermedia a libro
  - Intermediate folding panel
  - Mittiges Faltelement
- (C)**
- Ultima anta a libro
  - Last folding panel
  - Letzter Flügel

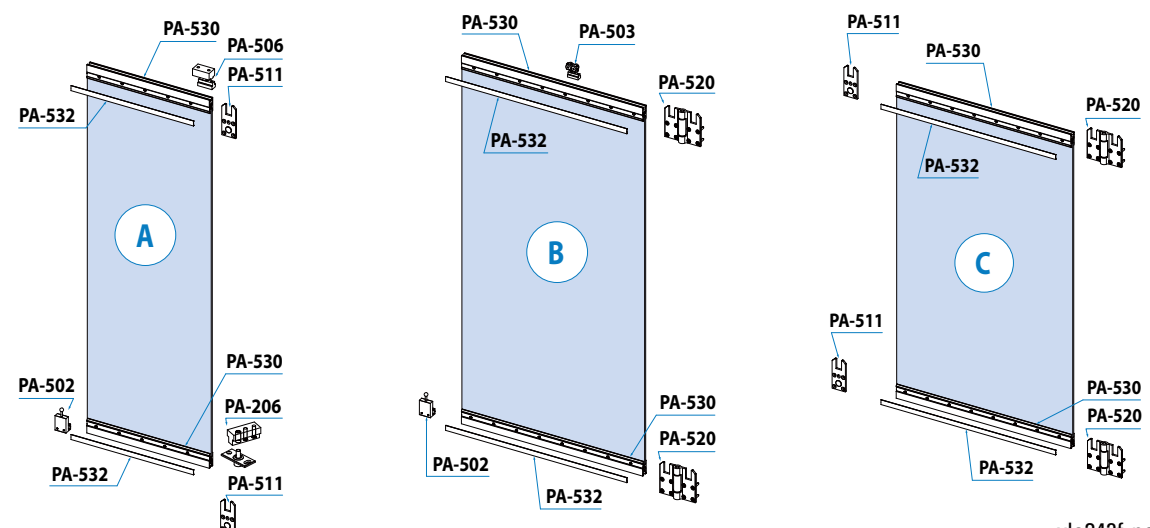

**(C)**

- Ultima anta a porta battente
- Last folding swing door
- Letzter Flügel als Dreh-Falt-Flügel

xla342f-new / xla342f-1 / xla342h

AN	At	N	LP	LA = LV	H	HV	HA
Alluminio anodizzato	Arie totali	Numero ante	Passaggio luce	Larghezza ante = Larghezza vetro	Altezza passaggio luce	Altezza vetro	Altezza anta
Aluminium anodized	Total clearances	Numbers panels	Clear opening width	Panel width = Glass width	Clear opening height	Glass height	Door height
Aluminium Silberfarbig	Summe alle Abstände Glas/Wand	Anzahl der Elemente	Lichte Durchgangsbreite	Flügelbreite = Glasbreite	Lichte durchgangshöhe	Glashöhe	Tür Höhe

SCORREVOLI A SOFFIETTO  
SLIDING CENTER SYSTEMS

# PA-560 CENTER FOLDING do-it-yourself

COME USARE **MY METALGLAS** / HOW TO USE **MY METALGLAS** / WIE MAN BENUTZT **MY METALGLAS**

**1** INSERIRE LE MISURE DEL TUO VANO E LE ANTE DESIDERATE  
ENTER THE MEASUREMENTS OF YOUR OPENING AND THE DOORS YOU REQUIRE  
GEBEN SIE DIE MASSE IHRER ÖFFNUNG EIN UND DIE ERFORDERLICHEN TÜREN

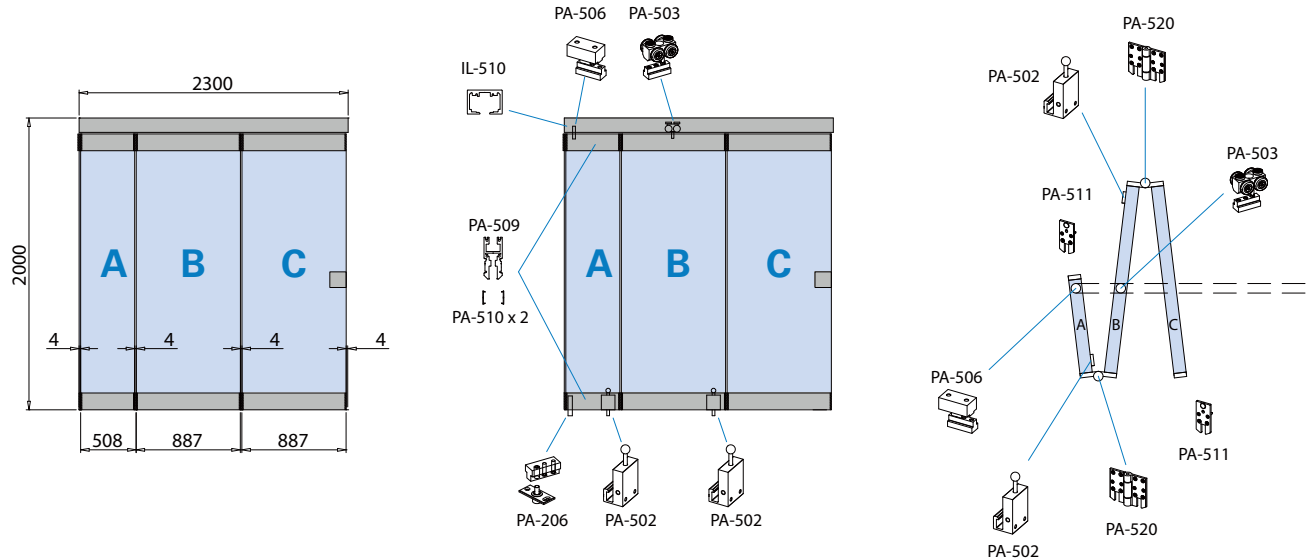

**2** SI OTTENGONO LE MISURE DEI VETRI AUTOMATICAMENTE  
THE MEASUREMENTS OF THE GLASS WILL BE GENERATED AUTOMATICALLY  
DIE ABMESSUNGEN DES GLASES WERDEN AUTOMATISCH BERECHNET

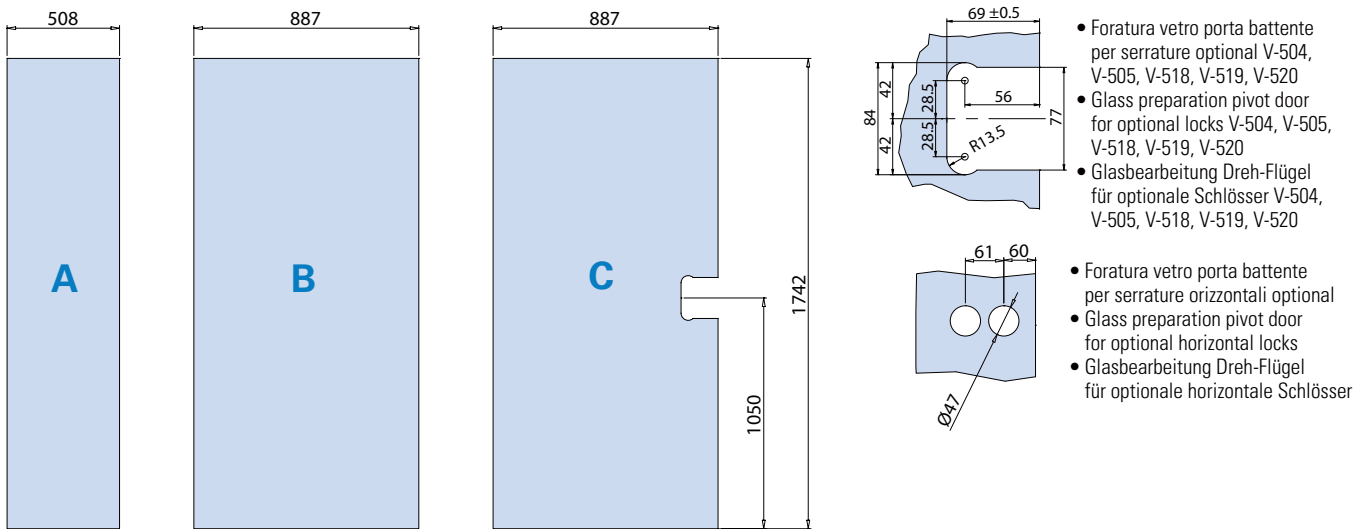

**3** SI OTTENGONO LE DISTINTE DI TAGLIO DEI PROFILI, DA ABBINARE AGLI ACCESSORI  
THE CUTTING SPECIFICATIONS OF THE PROFILES ARE OBTAINED, FOR MATCHING WITH THE ACCESSORIES  
SIE ERHALTEN EINE SPEZIFIKATION DER PROFILLÄNGEN ZUM ABGLEICHEN MIT DEM ZUBEHÖR

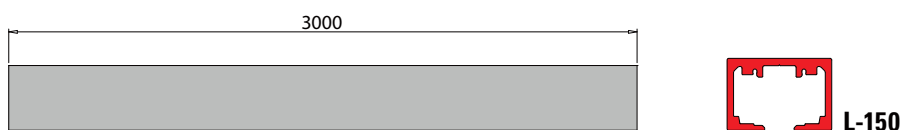

	PA-560 SET 2 (A)(B)(C)
	PA-560 SET 3 (A)(B)(B)(C)
	PA-560 SET 4 (A)(B)(B)(B)(C)
	PA-560 SET 5 (A)(B)(B)(B)(B)(C)

# PA-560 CENTER FOLDING do-it-yourself

COME ASSEMBLARE LE ANTE / HOW TO ASSEMBLE THE DOORS / WIE DIE TÜREN ZUSAMMENSETZT WERDEN

**TAGLIO PROFILI**  
PROFIL PREPARATION / PROFILBEARBEITUNG



**KIT ACCESSORI**  
ACCESSORY SETS / ZUBEHÖR SETS



**ANTA COMPLETA**  
COMPLETE DOOR / KOMPLETTE TÜR

ANTA A / DOOR A / TÜRA

PA-530 (2 x)  
PA-532 (4 x)

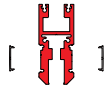

SUPERIORE / TOP / OBEN

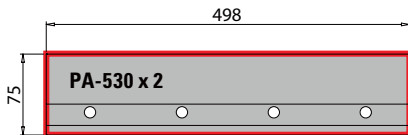

INFERIORE / BOTTOM / UNTEN

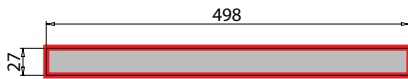

PA-532 x 4

**PA-560 ANTA A-10** (for glass 10 mm)  
**PA-560 ANTA A-12** (for glass 12 - 12,7 mm)  
PRIMA ANTA A LIBRO A  
FIRST FOLDING PANEL A  
ERSTER FALTELEMENT A

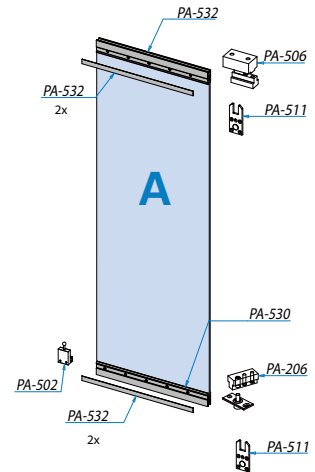

ANTA B / DOOR B / TÜRB

PA-530 (2 x)  
PA-532 (4 x)

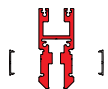

SUPERIORE / TOP / OBEN

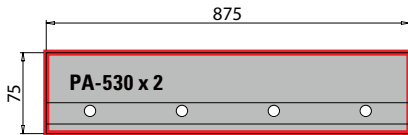

INFERIORE / BOTTOM / UNTEN

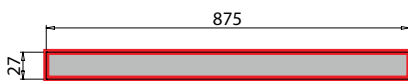

PA-532 x 4

**PA-560 ANTA B-10** (for glass 10 mm)  
**PA-560 ANTA B-12** (for glass 12 - 12,7 mm)  
ANTA INTERMEDIA A LIBRO B  
MIDDLE FOLDING PANEL B  
MITTIGES FALTELEMENT B

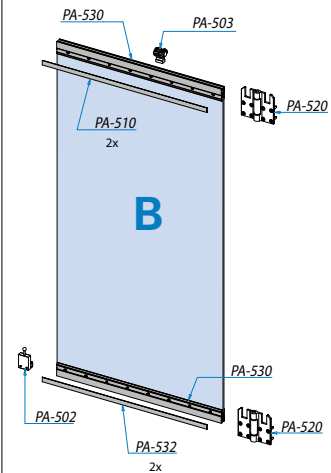

ANTA C / DOOR C / TÜRC

PA-530 (2 x)  
PA-532 (4 x)

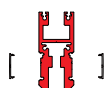

SUPERIORE / TOP / OBEN

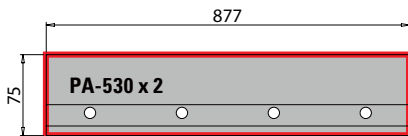

INFERIORE / BOTTOM / UNTEN

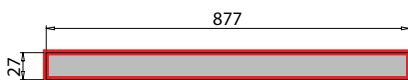

PA-532 x 4

**PA-560 ANTA C-10** (for glass 10 mm)  
**PA-560 ANTA C-12** (for glass 12 - 12,7 mm)  
ULTIMA ANTA A LIBRO C  
LAST FOLDING PANEL C  
LETZTER FLÜGEL C

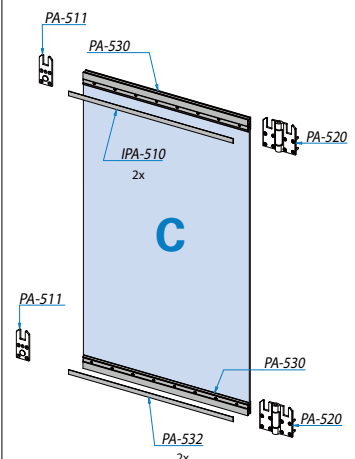
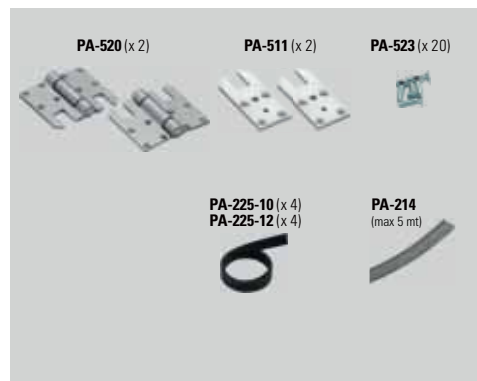

SCORREVOLI A SOFFIETTO  
SLIDING CENTER SYSTEMS

# L-2500 SOFFIETTO CENTER FOLDING

SCORREVOLI A SOFFIETTO / SLIDING CENTER FOLDING / FALT-SCHIEBEWANDSYSTEME

**MY METALGLAS**

€ ▶ C.301



- Sistema a soffietto con impacchettamento centrale, cerniere a vista e fori nel vetro, completo di binario standard h=44 mm x L=64 mm e carrello con 4 ruote.
- Center folding system, visible hinges and holes in glass, including rail h=44 mm x L=64 mm and carriage with 4 wheels.
- Faltschiebewandssystem mit mittiger Faltung, mit sichtbaren Bändern und Glasbohrungen, komplett mit Laufschiene h=44 mm x L=64 mm und Laufwagen mit 4 Rädern.

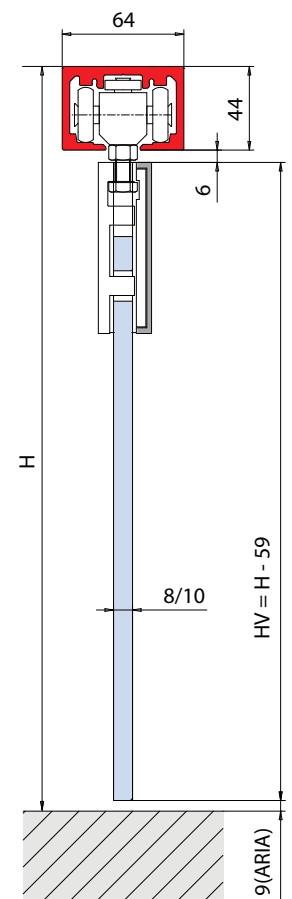

HV = H - 59

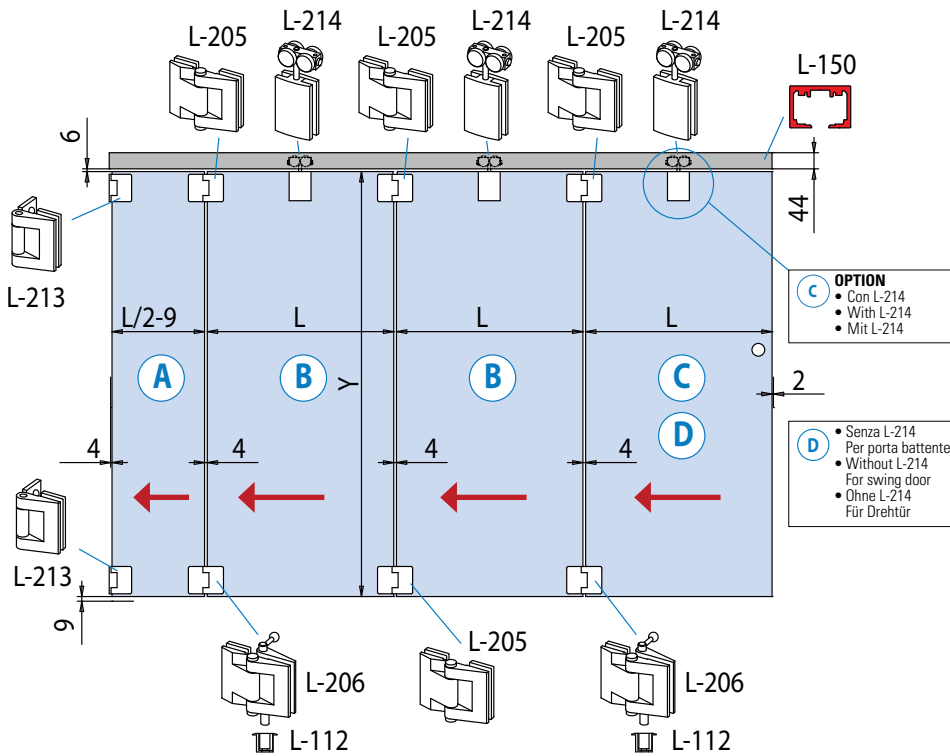
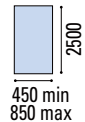
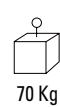
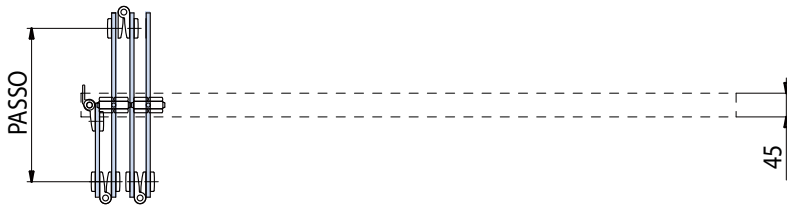

	L-2500 SET 1	(A) (C)
	L-2500 SET 2	(A) (B) (C) (D) option
	L-2500 SET 3	(A) (B) (B) (C) (D) option
	L-2500 SET 4	(A) (B) (B) (B) (C) (D) option
	L-2500 SET 5	(A) (B) (B) (B) (B) (C) (D) option

- Calcolo vetro
- Calculation glass
- Glasberechnung

$$At = (4 \times N) + 2$$

$$X = Lp - At$$

$$X = (L/2 - 9) + L \times (N-1)$$

$$L = (X + 9) / (N-0,5)$$

- (A)**
- Prima anta a libro
  - First folding panel
  - Erster Faltelement

- (B)**
- Anta intermedia a libro
  - Intermediate folding panel
  - Mittiges Faltelement

- (C) (D)**
- Ultima anta a libro
  - Last folding panel
  - Letzter Flügel

- (C) OPTION**
- Con L-214
  - With L-214
  - Mit L-214
- (D)**
- Senza L-214
  - Per porta battente
  - Without L-214
  - For swing door
  - Ohne L-214
  - Für Drehtür

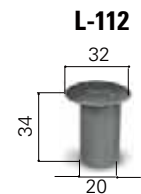

COMPONENTI / COMPONENTS / EINZELTEILE ▶ 98

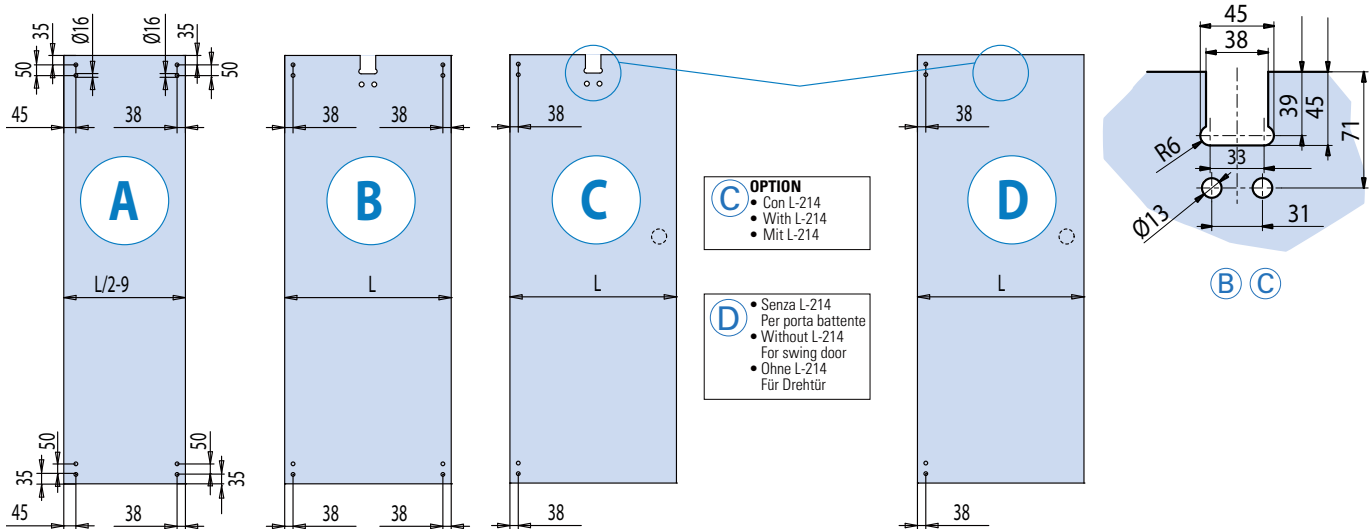

- (C) OPTION**
- Con L-214
  - With L-214
  - Mit L-214
- (D)**
- Senza L-214
  - Per porta battente
  - Without L-214
  - For swing door
  - Ohne L-214
  - Für Drehtür

xla182 / xla182-0

AN	At	N	LP	LA = LV	H	HV	HA
Alluminio anodizzato	Arie totali	Numero ante	Passaggio luce	Larghezza ante = Larghezza vetro	Altezza passaggio luce	Altezza vetro	Altezza anta
Aluminium anodized	Total clearances	Numbers panels	Clear opening width	Panel width = Glass width	Clear opening height	Glass height	Door height
Aluminium Silberfarbig	Summe alle Abstände Glas/Wand	Anzahl der Elemente	Lichte Durchgangsbreite	Flügelbreite = Glasbreite	Lichte durchgangshöhe	Glashöhe	Tür Höhe

# SISTEMI BALCONGLAS

## BALCONGLAS SYSTEMS

## SYSTEME BALCONGLAS

Sistemi a pannelli mobili in vetro impacchettabili senza baia di parcheggio

Slide and turn systems without parking bay / Schiebe-Dreh-Systeme mit beweglichen Glasmodulen ohne Parkraum



### BALCONGLAS FALCINO-50 ▶ 120

### BALCONGLAS FALCINO PARK-50 ▶ 124

- Sistema a pannelli mobili in vetro, impacchettabili senza la baia di parcheggio, con o senza canalina a terra, con profili anta con fori nel vetro.
- Slide and turn system, with or without floor channel and without parking bay, panels with holes in the glass.
- Schiebe-Dreh-Systeme mit beweglichen Glasmodulen ohne Parkraum, mit oder ohne Bodenschiene. Glas mit Bohrungen

#### FALCINO 50

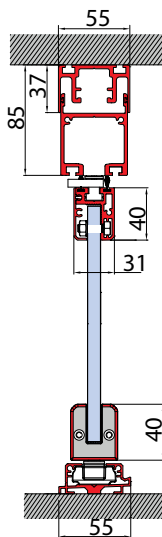
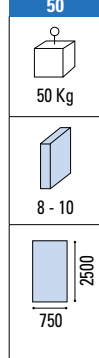

- Con canalina
- With floor channel
- Mit Bodenschiene

#### FALCINO PARK-50

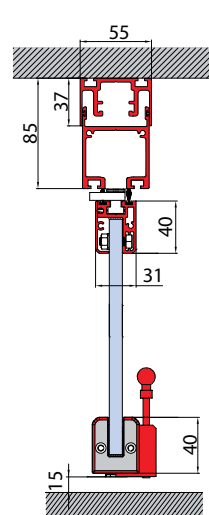
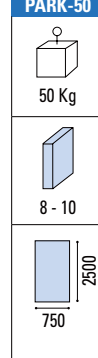

- Senza canalina
- Without floor channel
- Ohne Bodenschiene

LAVORAZIONE VETRO  
GLASS PREPARATION  
GLASBEARBEITUNG

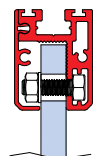

### BALCONGLAS FALCE-70 ▶ 128

### BALCONGLAS FALCE PARK-70 ▶ 132

- Sistema a pannelli mobili in vetro, impacchettabili senza la baia di parcheggio, con o senza canalina a terra, con profili anta senza fori nel vetro.
- Slide and turn system, with or without floor channel and without parking bay, panels without holes in the glass.
- Schiebe-Dreh-Systeme mit beweglichen Glasmodulen ohne Parkraum, mit oder ohne Bodenschiene. Glas ohne Bohrungen

#### FALCE 70

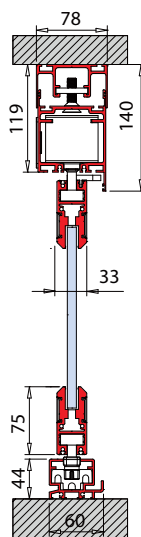
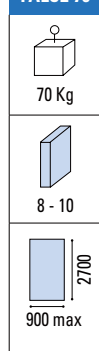

- Con canalina
- With floor channel
- Mit Bodenschiene

#### FALCE PARK 70

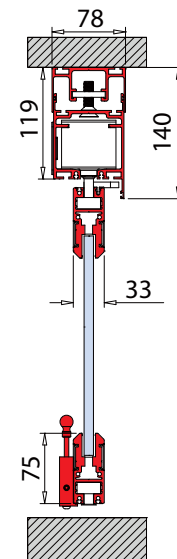
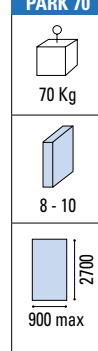



- Senza canalina
- Without floor channel
- Ohne Bodenschiene

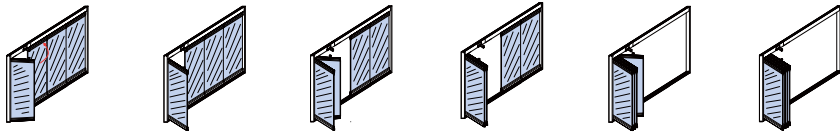



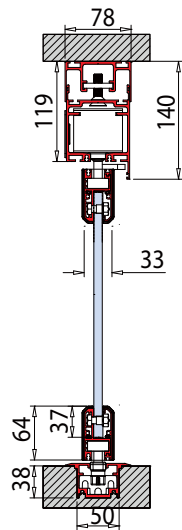

**BALCONGLAS FALCE-70B ▶ 136**
**BALCONGLAS FALCE PARK-70B ▶ 137**

- Sistema a pannelli mobili in vetro, impacchettabili senza la baia di parcheggio, con o senza canalina a terra, con profili anta con fori nel vetro.
- Slide and turn system, with or without floor channel and without parking bay, panels with holes in the glass.
- Schiebe-Dreh-Systeme mit beweglichen Glasmodulen ohne Parkraum, mit oder ohne Bodenschiene. Glas mit Bohrungen

<b>FALCE 70B</b>
 50 Kg
 8 - 10
 2500 800



- Con canalina
- With floor channel
- Mit Bodenschiene

<b>FALCE PARK 70B</b>
 50 Kg
 8 - 10
 2500 800

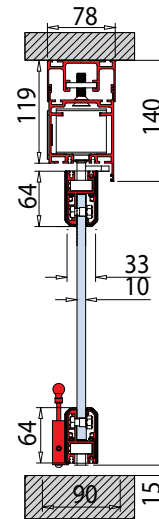

- Senza canalina
- Without floor channel
- Ohne Bodenschiene

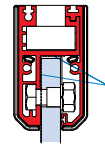

 LAVORAZIONE VETRO  
GLASS PREPARATION  
GLASBEARBEITUNG

**BALCONGLAS FALCE-ISO ▶ 138**
**BALCONGLAS FALCE PARK-ISO ▶ 142**

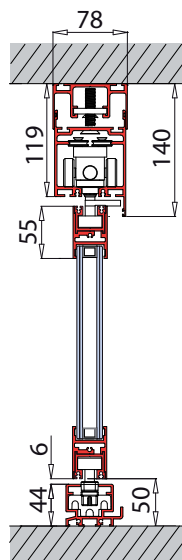
- Sistema a pannelli mobili in vetro, impacchettabili senza la baia di parcheggio, con o senza canalina a terra, con profili per anta intelaiata, misure standard per anta max 1000 x 3000 mm da tagliare cliente.
- Slide and turn system, with or without floor channel and without parking bay, with profiles for framed glass door, standard measures up to 1000 x 3000 mm, cut by installer.
- Schiebe-Dreh-Systeme mit beweglichen Glasmodulen ohne Parkraum, mit oder ohne Bodenschiene. Flügelrahmen für standard Tür max 1000 x 3000 mm. Schnitt bauseitig.

<b>FALCE ISO</b>
 70 Kg
 3,3-14-3,3
 2500 800 max



- Con canalina
- With floor channel
- Mit Bodenschiene

<b>FALCE PARK ISO</b>
 70 Kg
 3,3-14-3,3
 2500 800 max

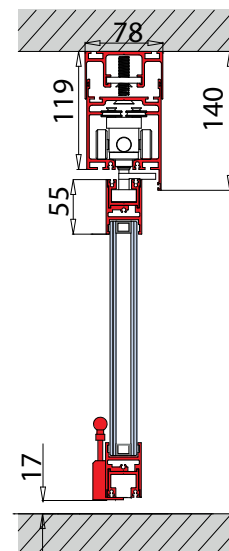

- Senza canalina
- Without floor channel
- Ohne Bodenschiene

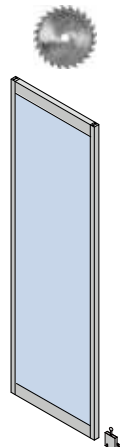

# BALCONGLAS FALCINO-50

**MY METALGLAS**

€▶ C.311

SISTEMA CON CANALINA / SYSTEMS WITH BOTTOM GUIDE / SYSTEM MIT BODENFÜHRUNG

- Sistema a pannelli mobili in vetro, impacchettabili senza la baia di parcheggio, con guida a terra, con profili anta con fori nel vetro.
- Slide and turn system, with floor channel and without parking bay, panels with holes in the glass.
- Schiebe-Dreh-System mit beweglichen Glasmodulen mit Glasbohrungen, mit Bodenführung und ohne Parkraum.



SISTEMI BALCONGLAS  
BALCONGLAS SYSTEMS

- Indicare sempre il verso di apertura e lo spessore vetro
- Please specify always opening direction and glass thickness
- Bitte immer Öffnungsrichtung und Glasdicke angeben

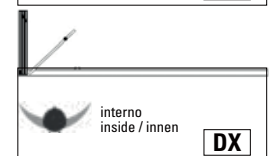
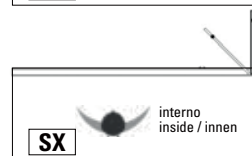
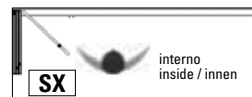

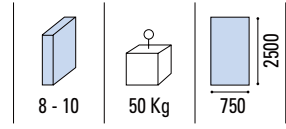
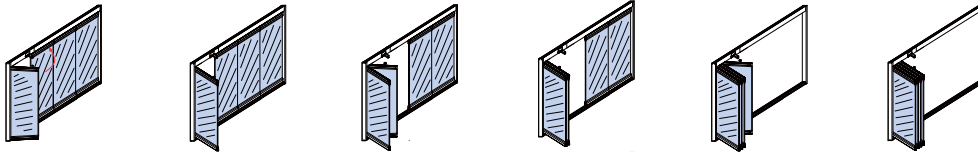

- Siliconare
- Glass to be glued
- Glas kleben

LAVORAZIONE VETRO  
GLASS PREPARATION  
GLASBEARBEITUNG

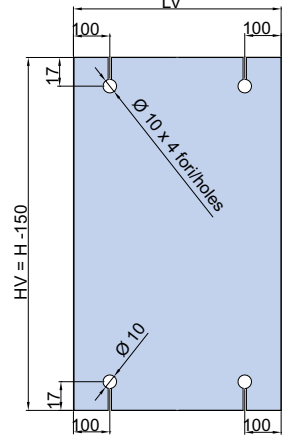

- FALCINO SET 2 (LB MAX = 1600 mm) (A C)
- FALCINO SET 3 (LB MAX = 2400 mm) (A B C)
- FALCINO SET 4 (LB MAX = 3200 mm) (A B B C)
- FALCINO SET 5 (LB MAX = 4000 mm) (A B B B C)
- FALCINO SET 6 (LB MAX = 4800 mm) (A B B B B C)
- FALCINO SET 7 (LB MAX = 5600 mm) (A B B B B B C)
- FALCINO SET 8 (LB MAX = 6400 mm) (A B B B B B B C)

- (A)
  - Porta laterale
  - Pivot door
  - Seitentür
- (B)
  - Anta intermedia scorrevole
  - Intermediate folding panel
  - Mittiges Faltelement
- (C)
  - Ultima anta
  - Last panel
  - End-Schiebeflügel

- Canalina incassata BGM-110
- Recessed floor profile BGM-110
- Versenkte Bodenschiene BGM-110

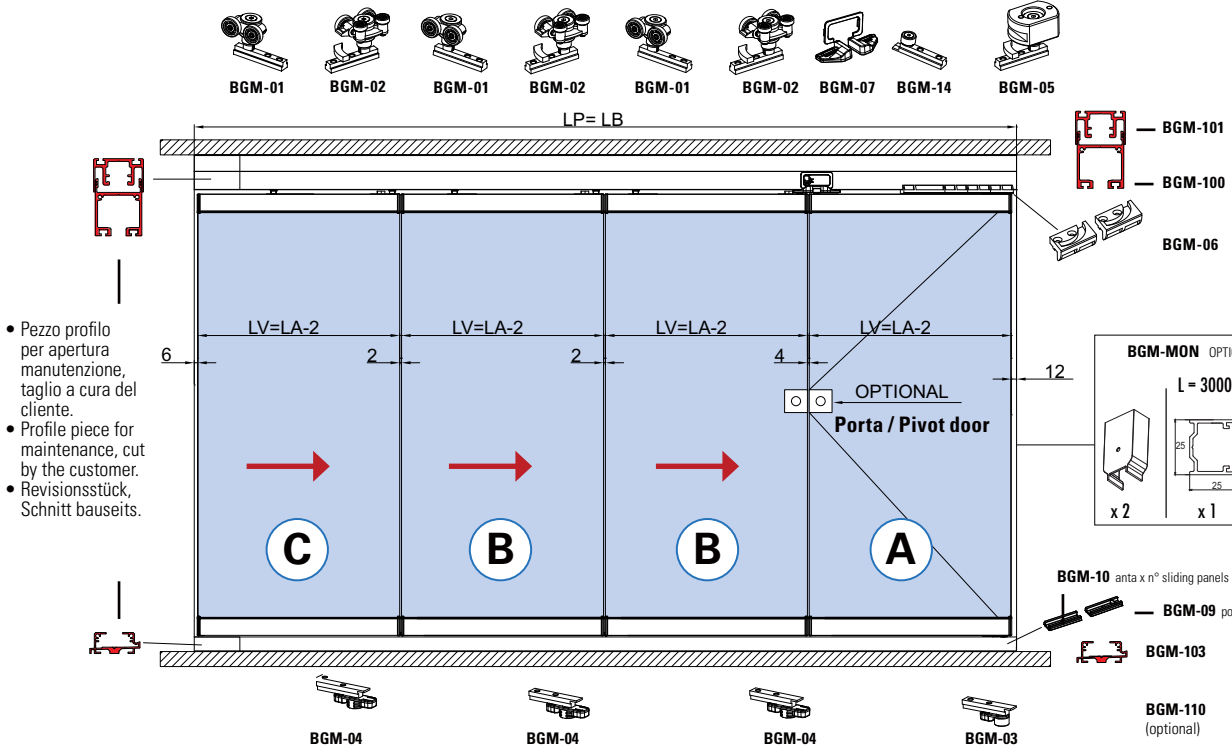
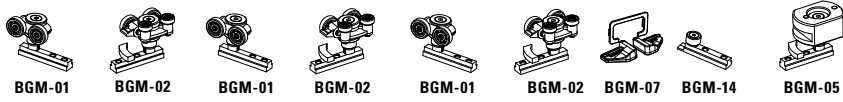

- Pezzo profilo per apertura manutenzione, taglio a cura del cliente.
- Profile piece for maintenance, cut by the customer.
- Revisionsstück, Schnitt bauseits.

**LP** Passaggio luce  
Clear opening width  
Lichte Durchgangsbreite

**LA = LV** Larghezza ante = Larghezza vetro  
Panel width = Glass width  
Flügelbreite = Glasbreite

**H** Altezza passaggio luce  
Clear opening height  
Lichte durchgangshöhe

**HV** Altezza vetro  
Glass height  
Glashöhe

**HA** Altezza anta  
Door height  
Tür Höhe

xme429

# BALCONGLAS FALCINO-50

**COME USARE MY METALGLAS / HOW TO USE MY METALGLAS / WIE MAN BENUTZT MY METALGLAS**

**1** INSERIRE LE MISURE DEL TUO VANO E LE ANTE DESIDERATE  
ENTER THE MEASUREMENTS OF YOUR OPENING AND THE DOORS YOU REQUIRE  
GEBEN SIE DIE MASSE IHRER ÖFFNUNG EIN UND DIE ERFORDERLICHEN TÜREN

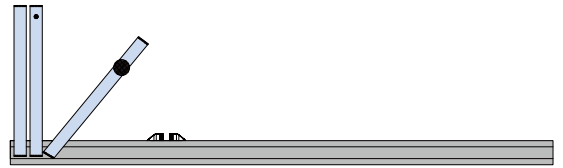
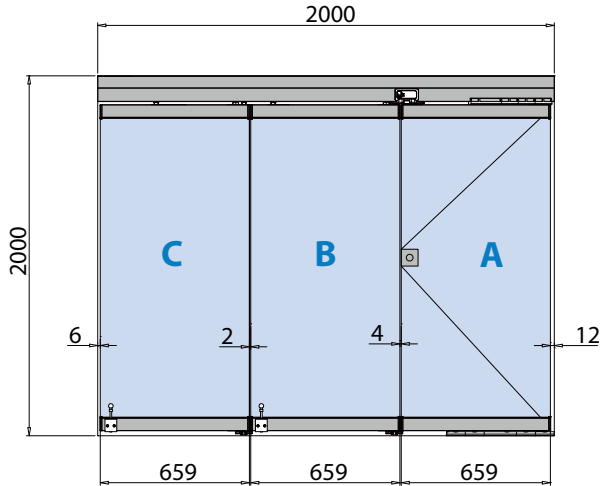

**2** SI OTTENGONO LE MISURE DEI VETRI AUTOMATICAMENTE  
THE MEASUREMENTS OF THE GLASS WILL BE GENERATED AUTOMATICALLY  
DIE ABMESSUNGEN DES GLASES WERDEN AUTOMATISCH BERECHNET

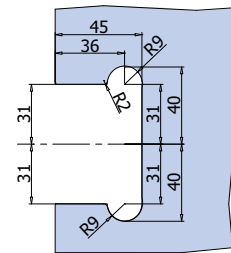
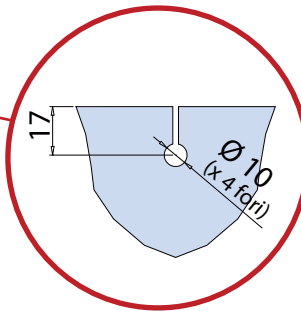
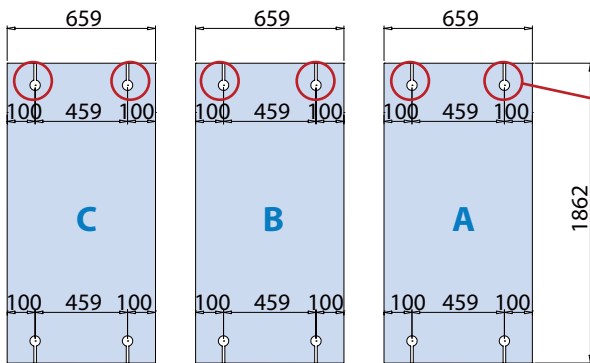

- Foratura vetro porta battente per serrature optional V-565, V-585, V-575  
Altre serrature disponibili catalogo Indoor sez. "E"
- Glass preparation pivot door for optional locks V-565, V-585, V-575. For other available locks see catalogue Indoor "E"
- Glasbearbeitung Dreh-Flügel für optionale Schlösser V-565, V-585, V-575. Für andere verfügbare Modelle siehe Katalog Indoor "E"

**3** SI OTTENGONO LE DISTINTE DI TAGLIO DEI PROFILI, DA ABBINARE AGLI ACCESSORI  
THE CUTTING SPECIFICATIONS OF THE PROFILES ARE OBTAINED, FOR MATCHING WITH THE ACCESSORIES  
SIE ERHALTEN EINE SPEZIFIKATION DER PROFILLÄNGEN ZUM ABGLEICHEN MIT DEM ZUBEHÖR

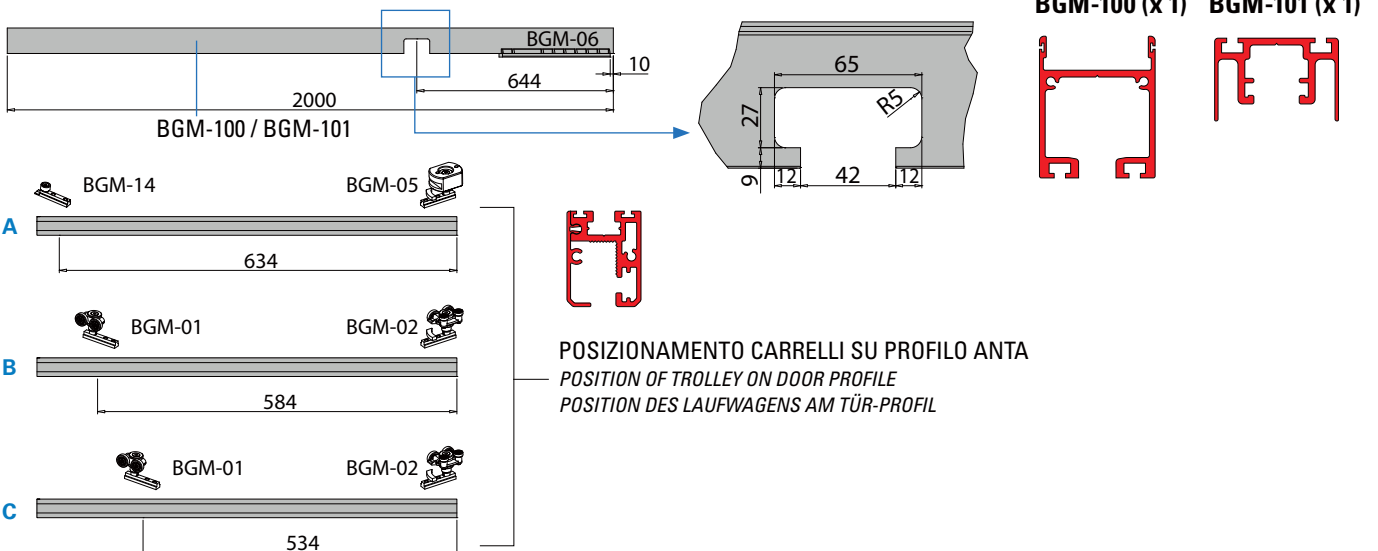

# BALCONGLAS FALCINO-50

## COME ASSEMBLARE LE ANTE / HOW TO ASSEMBLE THE DOORS / WIE DIE TÜREN ZUSAMMENSETZT WERDEN

TAGLIO PROFILI  
PROFIL PREPARATION / PROFILBEARBEITUNG



KIT ACCESSORI  
ACCESSORY SETS / ZUBEHÖR SETS



ANTA COMPLETA  
COMPLETE DOOR / KOMPLETTE TÜR

ANTA A / DOOR A / TÜR A

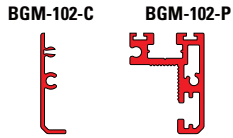

SUPERIORE / TOP / OBEN

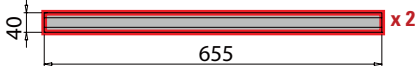

INFERIORE / BOTTOM / UNTEN

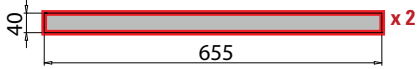

### BGM-ANTA-A-DX / BGM-ANTA-A-SX

PORTA LATERALE A  
LATERAL PIVOT DOOR A / DREHFLÜGEL A

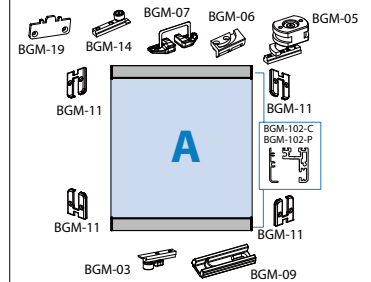
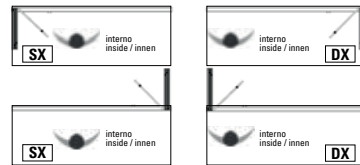
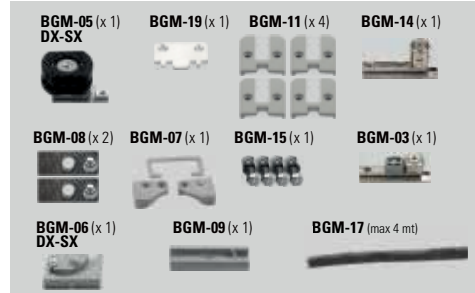

ANTA B / DOOR B / TÜR B

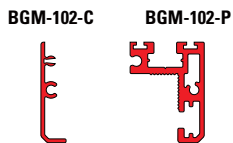

SUPERIORE / TOP / OBEN

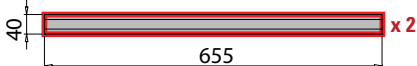

INFERIORE / BOTTOM / UNTEN

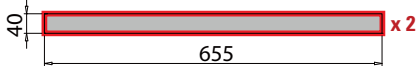

### BGM-ANTA-B-DX / BGM-ANTA-B-SX

ANTA INTERMEDIA B  
INTERMEDIATE PANEL B / MITTIGER FLÜGEL B

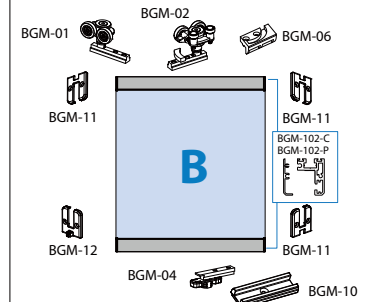
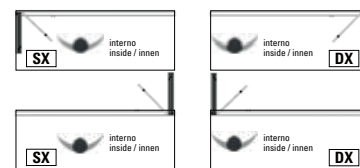
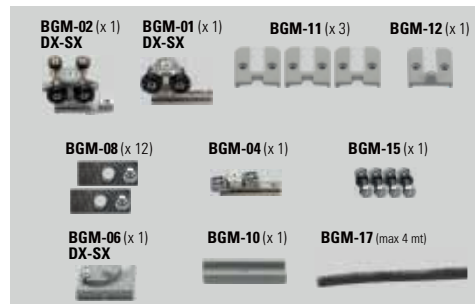

ANTA C / DOOR C / TÜR C

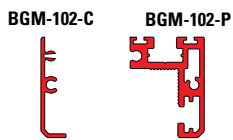

SUPERIORE / TOP / OBEN



INFERIORE / BOTTOM / UNTEN

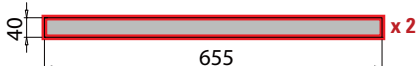

### BGM-ANTA-C-DX / BGM-ANTA-C-SX

ULTIMA ANTA C  
LAST PANEL C / ENDFLÜGEL C

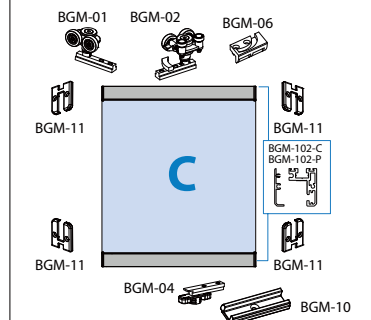
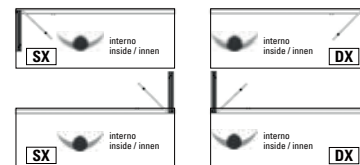
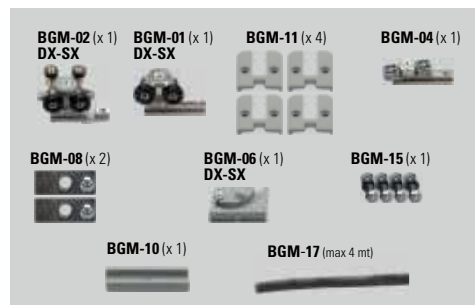

# BALCONGLAS FALCINO PARK-50

€▶ C.312

SISTEMA SENZA CANALINA / SYSTEMS WITHOUT BOTTOM GUIDE / SYSTEM OHNE BODENFÜHRUNG

- Sistema a pannelli mobili in vetro, impacchettabili senza guida a terra e senza baia di parcheggio, con profili anta con fori nel vetro.
- Slide and turn system, without floor channel and without parking bay, panels with holes in the glass.
- Schiebe-Dreh-System mit beweglichen Glasmodulen mit Glasbohrungen, ohne Bodenführung und ohne Parkraum .



SISTEMI BALCONGLAS  
BALCONGLAS SYSTEMS

- Indicare sempre il verso di apertura e lo spessore vetro
- Please specify always opening direction and glass thickness
- Bitte immer Öffnungsrichtung und Glasdicke angeben

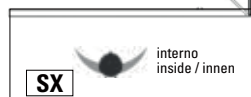
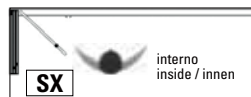

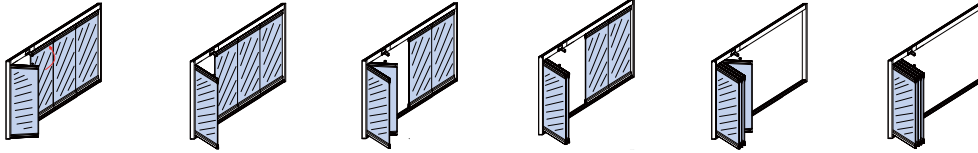

8 - 10	50 Kg	2500 750
--------	-------	-------------

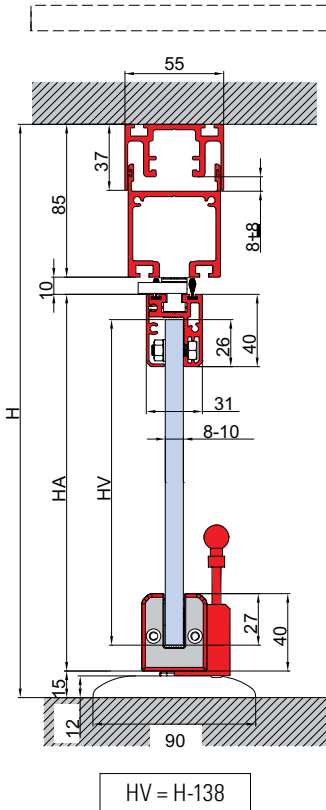

FALCINO PARK SET 2 (LB MAX = 1600 mm)	A C
FALCINO PARK SET 3 (LB MAX = 2400 mm)	A B C
FALCINO PARK SET 4 (LB MAX = 3200 mm)	A B B C
FALCINO PARK SET 5 (LB MAX = 4000 mm)	A B B B C
FALCINO PARK SET 6 (LB MAX = 4800 mm)	A B B B B C
FALCINO PARK SET 7 (LB MAX = 5600 mm)	A B B B B B C
FALCINO PARK SET 8 (LB MAX = 6400 mm)	A B B B B B B C

- Siliconare
- Glass to be glued
- Glas kleben

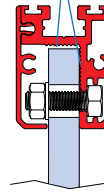

LAVORAZIONE VETRO  
GLASS PREPARATION  
GLASBEARBEITUNG

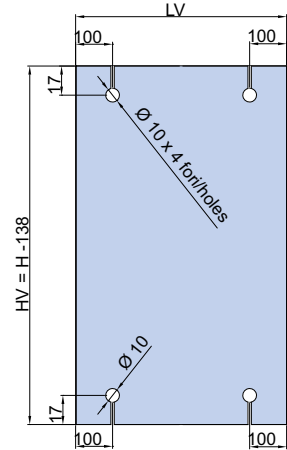

- A**
- Porta laterale
  - Pivot door
  - Seitentür
- B**
- Anta intermedia scorrevole
  - Intermediate folding panel
  - Mittiges Faltelement
- C**
- Ultima anta
  - Last panel
  - End-Schiebeflügel

**BGF-10**

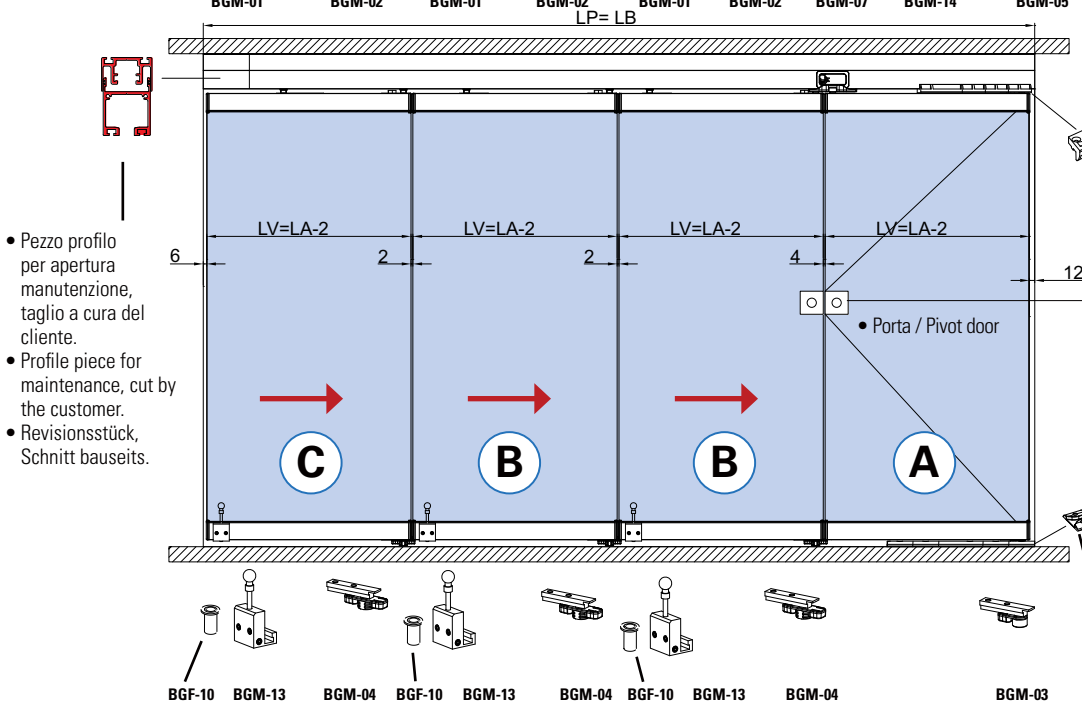
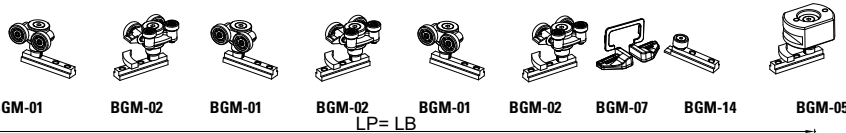

- Pezzo profilo per apertura manutenzione, taglio a cura del cliente.
- Profile piece for maintenance, cut by the customer.
- Revisionsstück, Schnitt bauseits.

OPTIONAL		
	V-565	CP
	V-569-2FLG	CP
	C-010	CR

SISTEMI BALCONGLAS  
BALCONGLAS SYSTEMS

<b>LP</b> Passaggio luce Clear opening width Lichte Durchgangsbreite	<b>LA = LV</b> Larghezza ante = Larghezza vetro Panel width = Glass width Flügelbreite = Glasbreite	<b>H</b> Altezza passaggio luce Clear opening height Lichte durchgangshöhe	<b>HV</b> Altezza vetro Glass height Glashöhe	<b>HA</b> Altezza anta Door height Tür Höhe
---	--	---	--	--

xme429

# BALCONGLAS FALCINO PARK-50

**COME USARE MY METALGLAS / HOW TO USE MY METALGLAS / WIE MAN BENUTZT MY METALGLAS**

**1** INSERIRE LE MISURE DEL TUO VANO E LE ANTE DESIDERATE  
ENTER THE MEASUREMENTS OF YOUR OPENING AND THE DOORS YOU REQUIRE  
GEBEN SIE DIE MASSE IHRER ÖFFNUNG EIN UND DIE ERFORDERLICHEN TÜREN

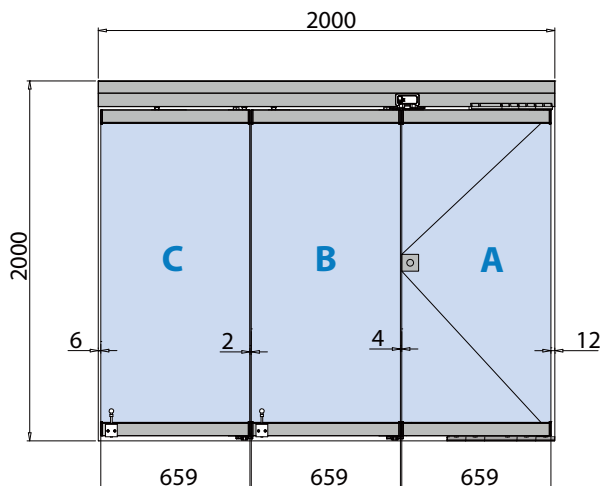

**2** SI OTTENGONO LE MISURE DEI VETRI AUTOMATICAMENTE  
THE MEASUREMENTS OF THE GLASS WILL BE GENERATED AUTOMATICALLY  
DIE ABMESSUNGEN DES GLASES WERDEN AUTOMATISCH BERECHNET

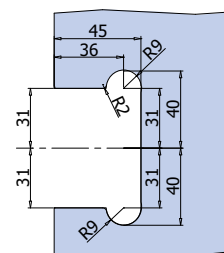
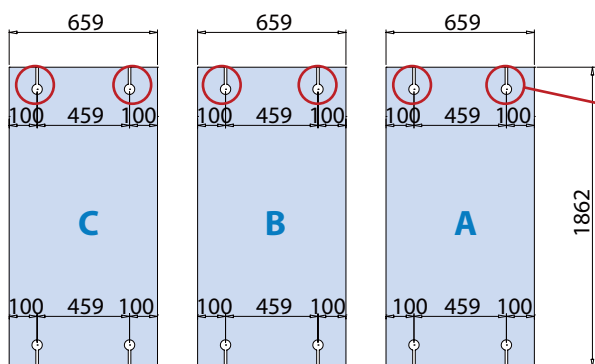

- Foratura vetro porta battente per serrature optional V-565, V-585, V-575  
Altre serrature disponibili catalogo Indoor sez. "E"
- Glass preparation pivot door for optional locks V-565, V-585, V-575. For other available locks see catalogue Indoor "E"
- Glasbearbeitung Dreh-Flügel für optionale Schlösser V-565, V-585, V-575. Für andere verfügbare Modelle siehe Katalog Indoor "E"

**3** SI OTTENGONO LE DISTINTE DI TAGLIO DEI PROFILI, DA ABBINARE AGLI ACCESSORI  
THE CUTTING SPECIFICATIONS OF THE PROFILES ARE OBTAINED, FOR MATCHING WITH THE ACCESSORIES  
SIE ERHALTEN EINE SPEZIFIKATION DER PROFILLÄNGEN ZUM ABGLEICHEN MIT DEM ZUBEHÖR

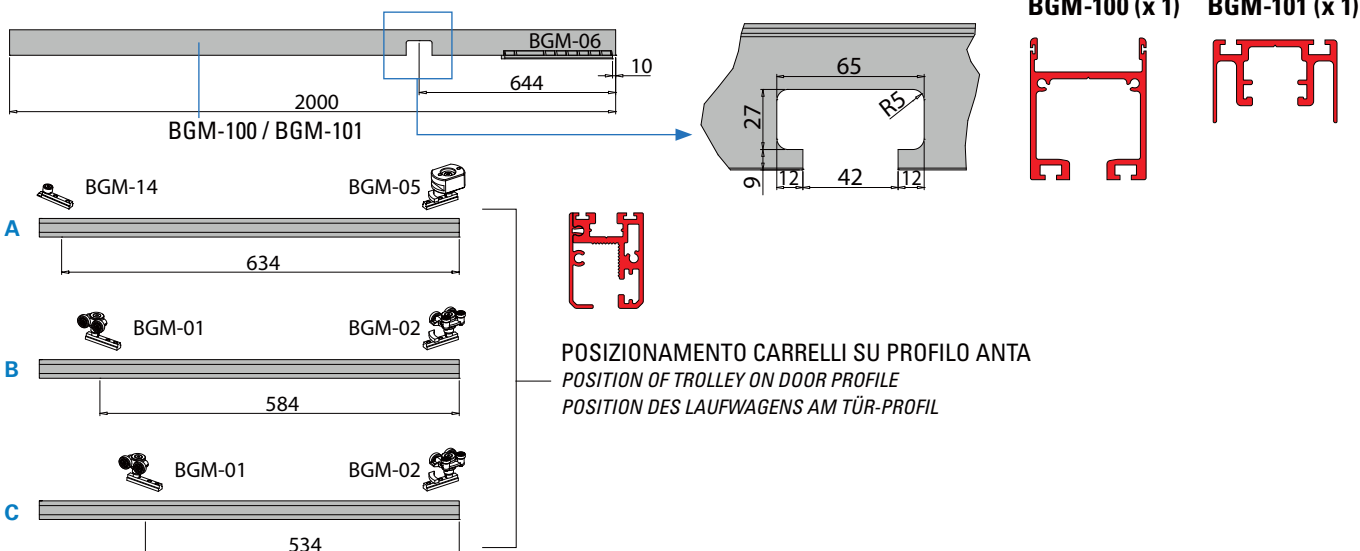



# BALCONGLAS FALCINO PARK-50

## COME ASSEMBLARE LE ANTE / HOW TO ASSEMBLE THE DOORS / WIE DIE TÜREN ZUSAMMENSETZT WERDEN

TAGLIO PROFILI  
PROFIL PREPARATION / PROFILBEARBEITUNG



KIT ACCESSORI  
ACCESSORY SETS / ZUBEHÖR SETS



ANTA COMPLETA  
COMPLETE DOOR / KOMPLETTE TÜR

ANTA A / DOOR A / TÜR A

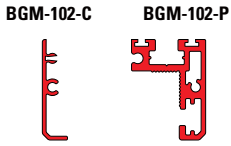

SUPERIORE / TOP / OBEN

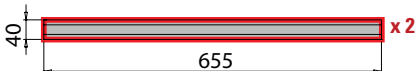

INFERIORE / BOTTOM / UNTEN

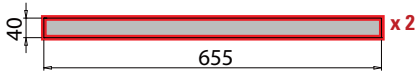

**BGM-PARK-A-DX / BGM-PARK-A-SX**  
PORTA LATERALE A  
LATERAL PIVOT DOOR A / DREHFLÜGEL A

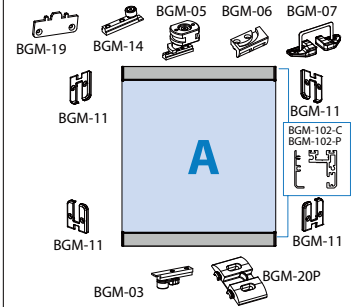
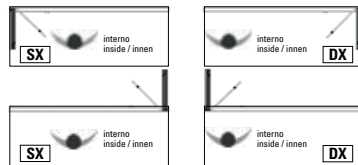
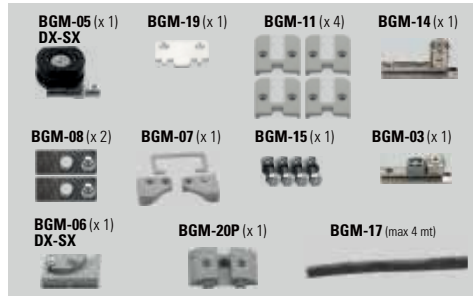

ANTA B / DOOR B / TÜR B

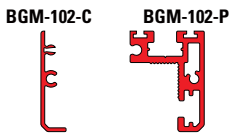

SUPERIORE / TOP / OBEN

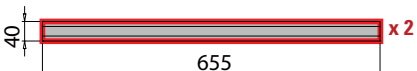

INFERIORE / BOTTOM / UNTEN

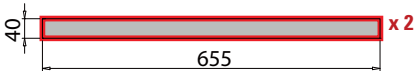

**BGM-PARK-B-DX / BGM-PARK-B-SX**  
ANTA INTERMEDIA B  
INTERMEDIATE PANEL B / MITTIGE FLÜGEL B

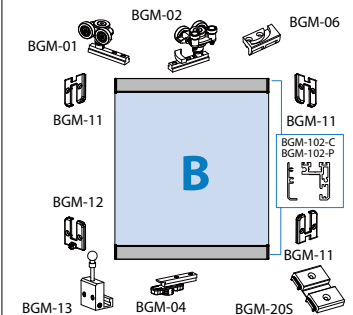
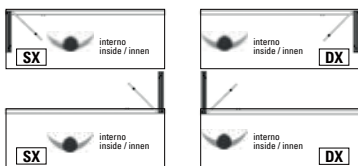
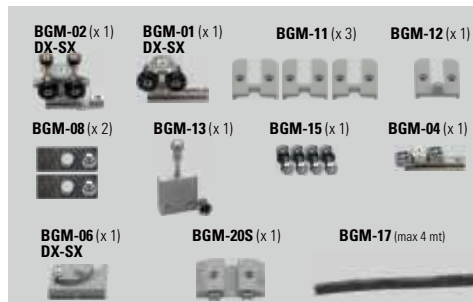

ANTA C / DOOR C / TÜR C

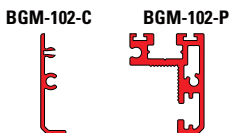

SUPERIORE / TOP / OBEN



INFERIORE / BOTTOM / UNTEN

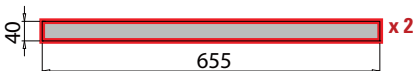

**BGM-PARK-C-DX / BGM-PARK-C-SX**  
ULTIMA ANTA C  
LAST PANEL C / ENDFLÜGEL C

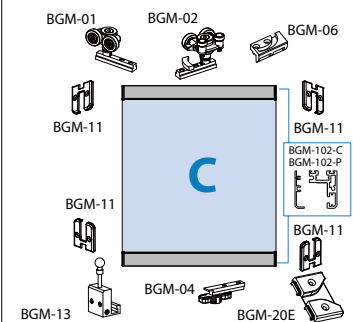
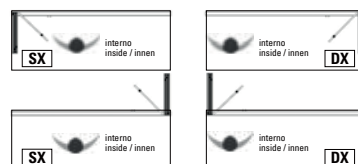
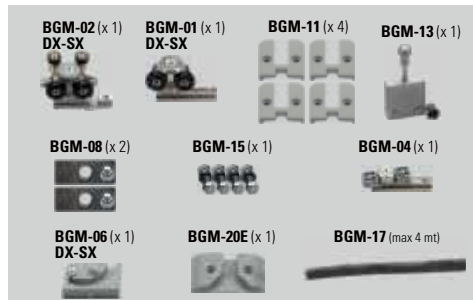

# BALCONGLAS FALCE-70

**MY METALGLAS**

SISTEMA CON CANALINA / SYSTEMS WITH BOTTOM GUIDE / SYSTEM MIT BODENFÜHRUNG

€ ▶ C.322

- Sistema a pannelli mobili in vetro, impacchettabili senza la baia di parcheggio, con guida a terra, con profili anta senza fori nel vetro.
- Slide and turn system, with floor channel and without parking bay, panels without holes in the glass.
- Schiebe-Dreh-System mit beweglichen Glasmodulen, mit Bodenführung und ohne Parkraum, ohne Glasbohrungen.



SISTEMI BALCONGLAS  
BALCONGLAS SYSTEMS

- Indicare sempre il verso di apertura e lo spessore vetro
- Please specify always opening direction and glass thickness
- Bitte immer Öffnungsrichtung und Glasdicke angeben

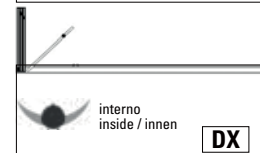
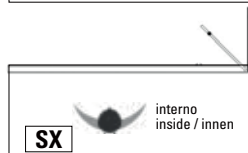
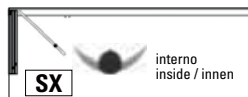

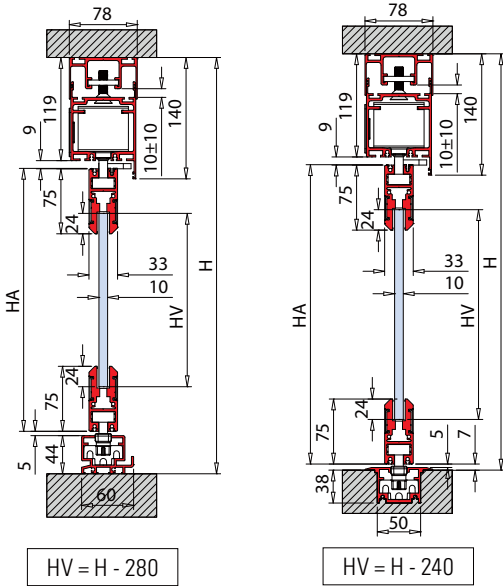
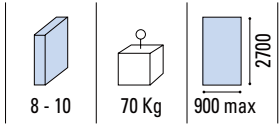
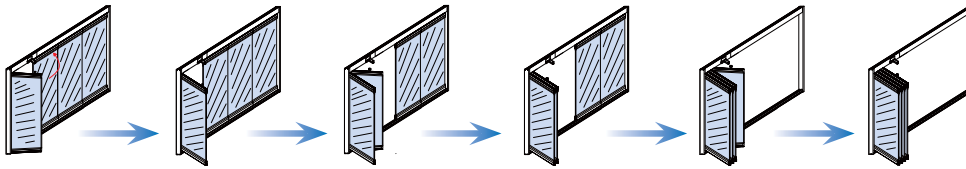

- Canalina incassata
- Recessed floor profile
- Versenkte Bodenschiene

BGF-SET 2 (LB MAX = 2000 mm)	(A) (B)
BGF-SET 3 (LB MAX = 3000 mm)	(A) (B) (B)
BGF-SET 4 (LB MAX = 4000 mm)	(A) (B) (B) (B)
BGF-SET 5 (LB MAX = 5000 mm)	(A) (B) (B) (B) (B)
BGF-SET 6 (LB MAX = 6000 mm)	(A) (B) (B) (B) (B) (B)
BGF-SET 7 (LB MAX = 6000 mm)	(A) (B) (B) (B) (B) (B) (B)

- (A)**
- Porta laterale
  - Pivot door
  - Seitentür
- (B)**
- Anta intermedia scorrevole
  - Intermediate folding panel
  - Mittiges Faltelement

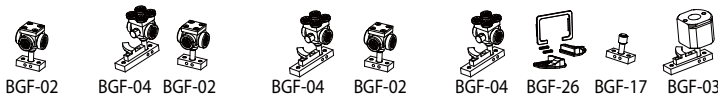

LP = LB

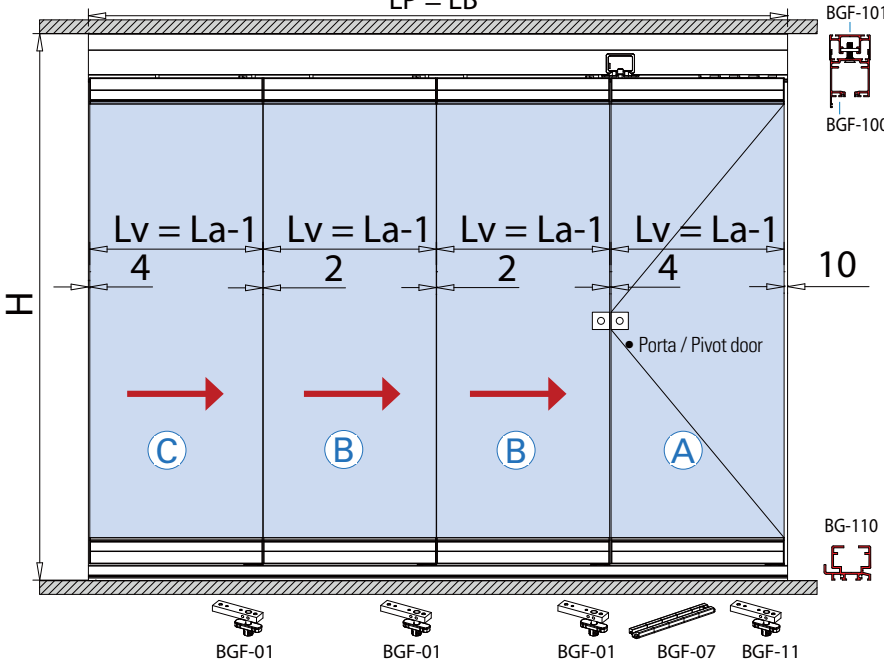

OPTIONAL		
	V-565	CP
	V-569-2FLG	CP
	C-010	CR
	WRU-M 80/50 MT5	

- Altre serrature disponibili vedi cap. E
- Other available locks see section E
- Andere Schlösser siehe im Kapitel E

xme355

AN	At	N	LP	LA = LV	H	HV	HA
Alluminio anodizzato	Arie totali	Numero ante	Passaggio luce	Larghezza ante = Larghezza vetro	Altezza passaggio luce	Altezza vetro	Altezza anta
Aluminium anodized	Total clearances	Numbers panels	Clear opening width	Panel width = Glass width	Clear opening height	Glass height	Door height
Aluminium Silberfarbig	Summe alle Abstände Glas/Wand	Anzahl der Elemente	Lichte Durchgangsbreite	Flügelbreite = Glasbreite	Lichte durchgangshöhe	Glashöhe	Tür Höhe

# BALCONGLAS FALCE-70

COME USARE MY METALGLAS / HOW TO USE MY METALGLAS / WIE MAN BENUTZT MY METALGLAS

**1** INSERIRE LE MISURE DEL TUO VANO E LE ANTE DESIDERATE  
ENTER THE MEASUREMENTS OF YOUR OPENING AND THE DOORS YOU REQUIRE  
GEBEN SIE DIE MASSE IHRER ÖFFNUNG EIN UND DIE ERFORDERLICHEN TÜREN

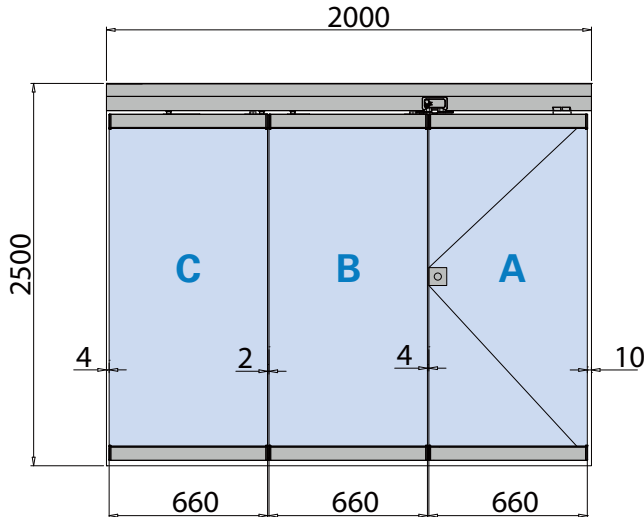

**2** SI OTTENGONO LE MISURE DEI VETRI AUTOMATICAMENTE  
THE MEASUREMENTS OF THE GLASS WILL BE GENERATED AUTOMATICALLY  
DIE ABMESSUNGEN DES GLASES WERDEN AUTOMATISCH BERECHNET

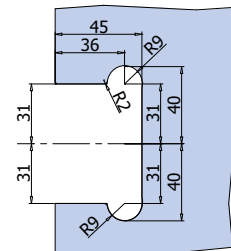
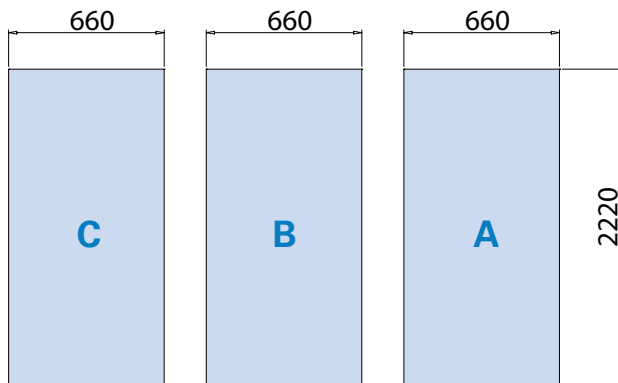

- Foratura vetro porta battente per serrature optional V-565, V-585, V-575  
Altre serrature disponibili catalogo Indoor sez. "E"
- Glass preparation pivot door for optional locks V-565, V-585, V-575. For other available locks see catalogue Indoor "E"
- Glasbearbeitung Dreh-Flügel für optionale Schlösser V-565, V-585, V-575. Für andere verfügbare Modelle siehe Katalog Indoor "E"

**3** SI OTTENGONO LE DISTINTE DI TAGLIO DEI PROFILI, DA ABBINARE AGLI ACCESSORI  
THE CUTTING SPECIFICATIONS OF THE PROFILES ARE OBTAINED, FOR MATCHING WITH THE ACCESSORIES  
SIE ERHALTEN EINE SPEZIFIKATION DER PROFILLÄNGEN ZUM ABGLEICHEN MIT DEM ZUBEHÖR

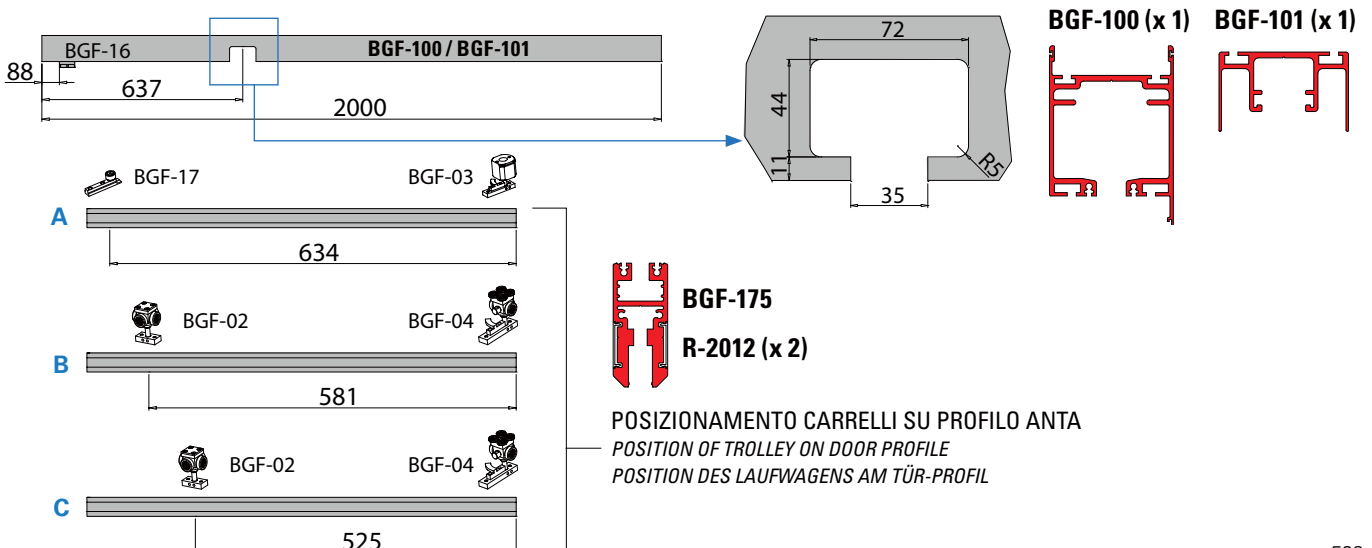

# BALCONGLAS FALCE-70

## COME ASSEMBLARE LE ANTE / HOW TO ASSEMBLE THE DOORS / WIE DIE TÜREN ZUSAMMENSETZT WERDEN

**TAGLIO PROFILI**  
PROFIL PREPARATION / PROFILBEARBEITUNG

**+**

KIT ACCESSORI  
ACCESSORY SETS / ZUBEHÖR SETS

**=**

ANTA COMPLETA  
COMPLETE DOOR / KOMPLETTE TÜR

**ANTA A / DOOR A / TÜR A**

**SUPERIORE + INFERIORE / TOP + BOTTOM / UNTEN + OBEN**

BGF-175 (x 2) + R-2012 (x 4)

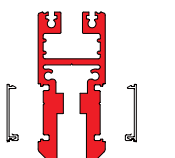
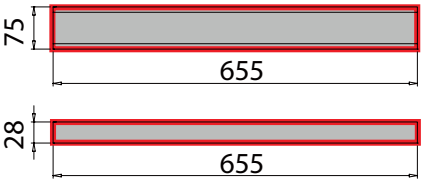
**BGF-ANT-A-DX-8 / BGF-ANT-A-DX-8 (for glass 8 mm)**  
**BGF-ANT-A-DX-10 / BGF-ANT-A-DX-10 (for glass 10 mm)**  
PORTA LATERALE A / LATERAL PIVOT DOOR A / DREHFLÜGEL A



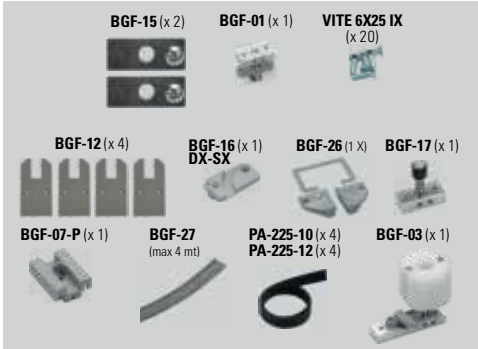
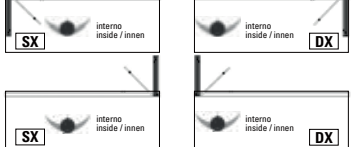

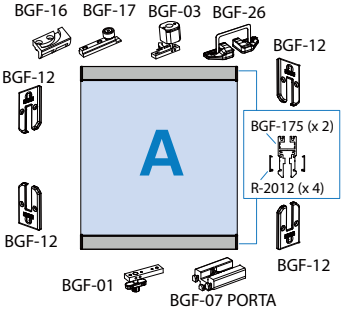

**ANTA B / DOOR B / TÜR B**

**SUPERIORE + INFERIORE / TOP + BOTTOM / UNTEN + OBEN**

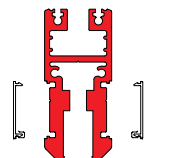
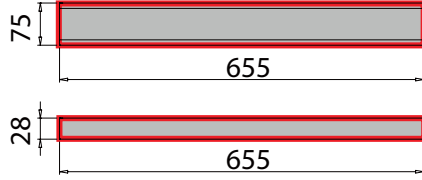
BGF-175 (x 2) + R-2012 (x 4)

**BGF-ANT-B-DX-8 / BGF-ANT-B-DX-8 (for glass 8 mm)**  
**BGF-ANT-B-DX-10 / BGF-ANT-B-DX-10 (for glass 10 mm)**  
ANTA INTERMEDIA B / INTERMEDIATE PANEL B / MITTIGE FLÜGEL B



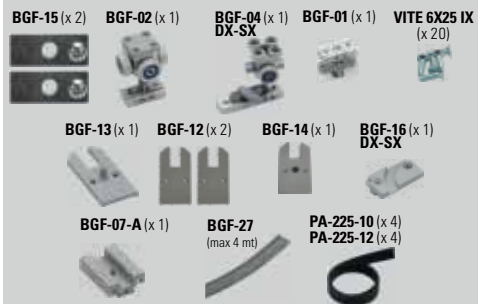
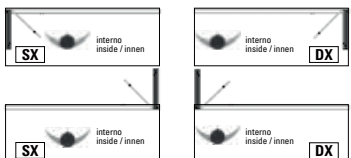

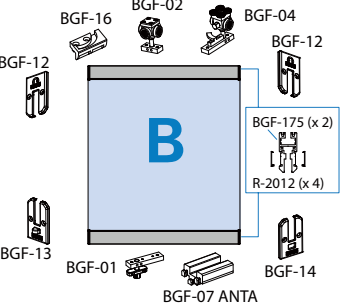

**ANTA C / DOOR C / TÜR C**

**SUPERIORE + INFERIORE / TOP + BOTTOM / UNTEN + OBEN**

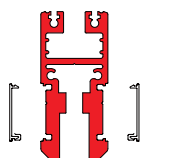
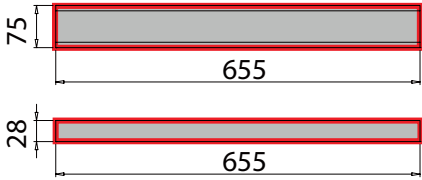
BGF-175 (x 2) + R-2012 (x 4)

**BGF-ANT-C-DX-8 / BGF-ANT-C-DX-8 (for glass 8 mm)**  
**BGF-ANT-C-DX-10 / BGF-ANT-C-DX-10 (for glass 10 mm)**  
ULTIMA ANTA C / LAST PANEL C / ENDFLÜGEL C

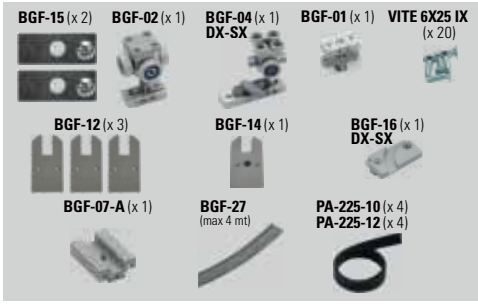
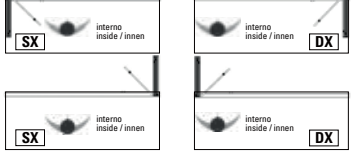

# BALCONGLAS FALCE PARK-70

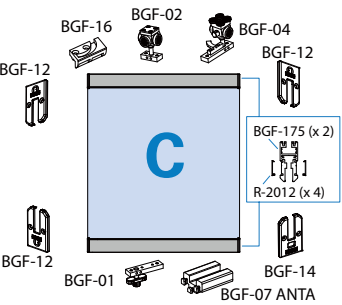
**MY METALGLAS**

SISTEMA SENZA CANALINA / SYSTEMS WITHOUT BOTTOM GUIDE / SYSTEM OHNE BODENFÜHRUNG

€ ▶ C.323

- Sistema a pannelli mobili in vetro, impacchettabili senza guida a terra e senza baia di parcheggio, con profili anta senza fori nel vetro.
- Slide and turn system, without floor channel and without parking bay, panels without holes in the glass.
- Schiebe-Dreh-System mit beweglichen Glasmodulen, ohne Bodenführung und ohne Parkraum, ohne Glasbohrungen.



SISTEMI BALCONGLAS  
BALCONGLAS SYSTEMS

- Indicare sempre il verso di apertura e lo spessore vetro
- Please specify always opening direction and glass thickness
- Bitte immer Öffnungsrichtung und Glasdicke angeben

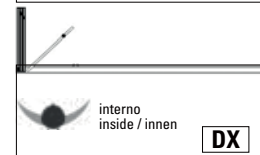
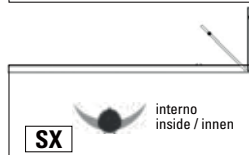
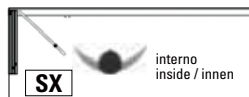

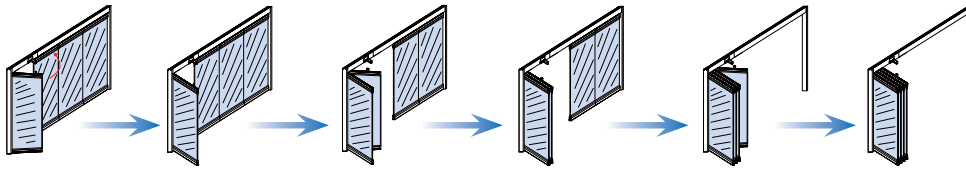

8 - 10	70 Kg	900 max 2700
--------	-------	-----------------

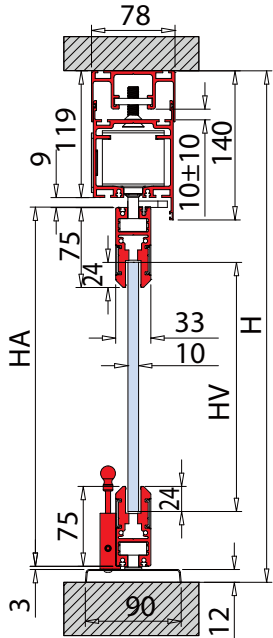

HV = H - 247

BGF-PARK 2 (LB MAX = 2000 mm)	(A) (B)
BGF-PARK 3 (LB MAX = 3000 mm)	(A) (B) (B)
BGF-PARK 4 (LB MAX = 4000 mm)	(A) (B) (B) (B)
BGF-PARK 5 (LB MAX = 5000 mm)	(A) (B) (B) (B) (B)
BGF-PARK 6 (LB MAX = 6000 mm)	(A) (B) (B) (B) (B) (B)
BGF-PARK 7 (LB MAX = 6000 mm)	(A) (B) (B) (B) (B) (B) (B)

- (A)**
- Porta laterale
  - Pivot door
  - Seitentür
- (B)**
- Anta intermedia scorrevole
  - Intermediate folding panel
  - Mittiges Faltelement

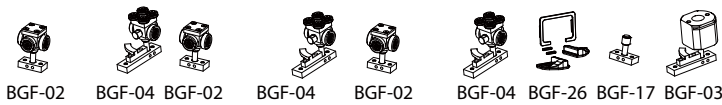

LP = LB

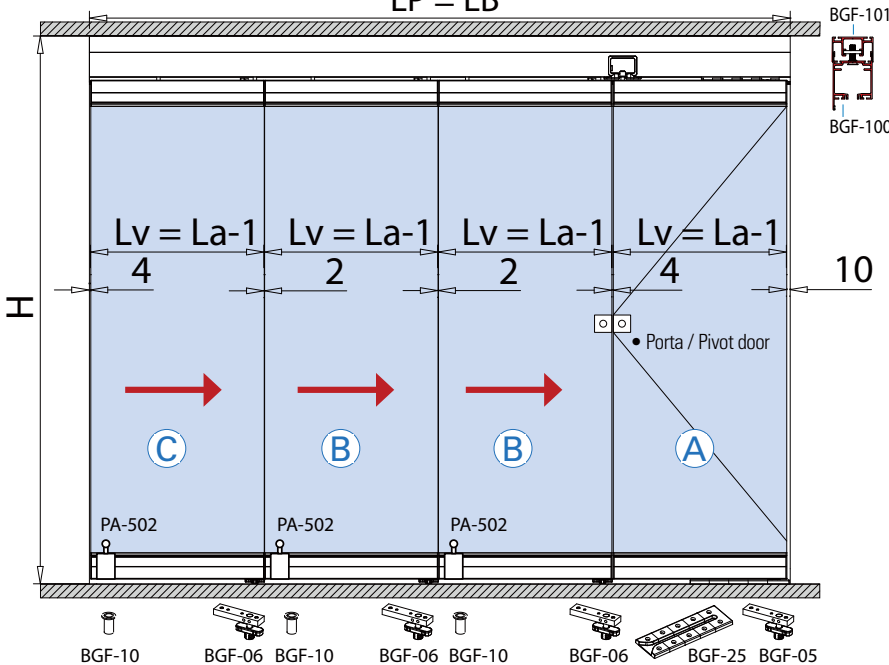

OPTIONAL		
	V-565	CP
	V-569-2FLG	CP
	C-010	CR
	WRU-M 80/50 MT5	

- Altre serrature disponibili vedi cap. E
- Other available locks see section E
- Andere Schlösser siehe im Kapitel E

xme355

<b>AN</b> Alluminio anodizzato Aluminium anodized Aluminium Silberfarbig	<b>At</b> Arie totali Total clearances Summe alle Abstände Glas/Wand	<b>N</b> Numero ante Numbers panels Anzahl der Elemente	<b>LP</b> Passaggio luce Clear opening width Lichte Durchgangsbreite	<b>LA = LV</b> Larghezza ante = Larghezza vetro Panel width = Glass width Flügelbreite = Glasbreite	<b>H</b> Altezza passaggio luce Clear opening height Lichte durchgangshöhe	<b>HV</b> Altezza vetro Glass height Glashöhe	<b>HA</b> Altezza anta Door height Tür Höhe
---	---	--	---	--	---	--	--

# BALCONGLAS FALCE PARK-70

**COME USARE MY METALGLAS / HOW TO USE MY METALGLAS / WIE MAN BENUTZT MY METALGLAS**

**1** INSERIRE LE MISURE DEL TUO VANO E LE ANTE DESIDERATE  
ENTER THE MEASUREMENTS OF YOUR OPENING AND THE DOORS YOU REQUIRE  
GEBEN SIE DIE MASSE IHRER ÖFFNUNG EIN UND DIE ERFORDERLICHEN TÜREN

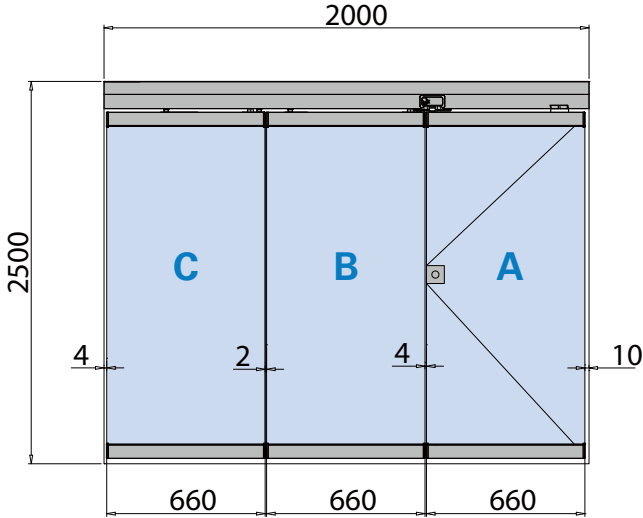

**2** SI OTTENGONO LE MISURE DEI VETRI AUTOMATICAMENTE  
THE MEASUREMENTS OF THE GLASS WILL BE GENERATED AUTOMATICALLY  
DIE ABMESSUNGEN DES GLASES WERDEN AUTOMATISCH BERECHNET

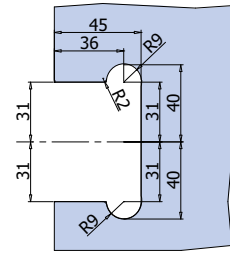
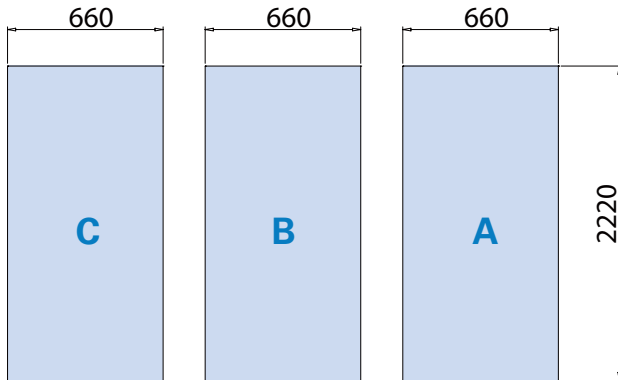

- Foratura vetro porta battente per serrature optional V-565, V-585, V-575  
Altre serrature disponibili catalogo Indoor sez. "E"
- Glass preparation pivot door for optional locks V-565, V-585, V-575. For other available locks see catalogue Indoor "E"
- Glasbearbeitung Dreh-Flügel für optionale Schlösser V-565, V-585, V-575. Für andere verfügbare Modelle siehe Katalog Indoor "E"

**3** SI OTTENGONO LE DISTINTE DI TAGLIO DEI PROFILI, DA ABBINARE AGLI ACCESSORI  
THE CUTTING SPECIFICATIONS OF THE PROFILES ARE OBTAINED, FOR MATCHING WITH THE ACCESSORIES  
SIE ERHALTEN EINE SPEZIFIKATION DER PROFILLÄNGEN ZUM ABGLEICHEN MIT DEM ZUBEHÖR

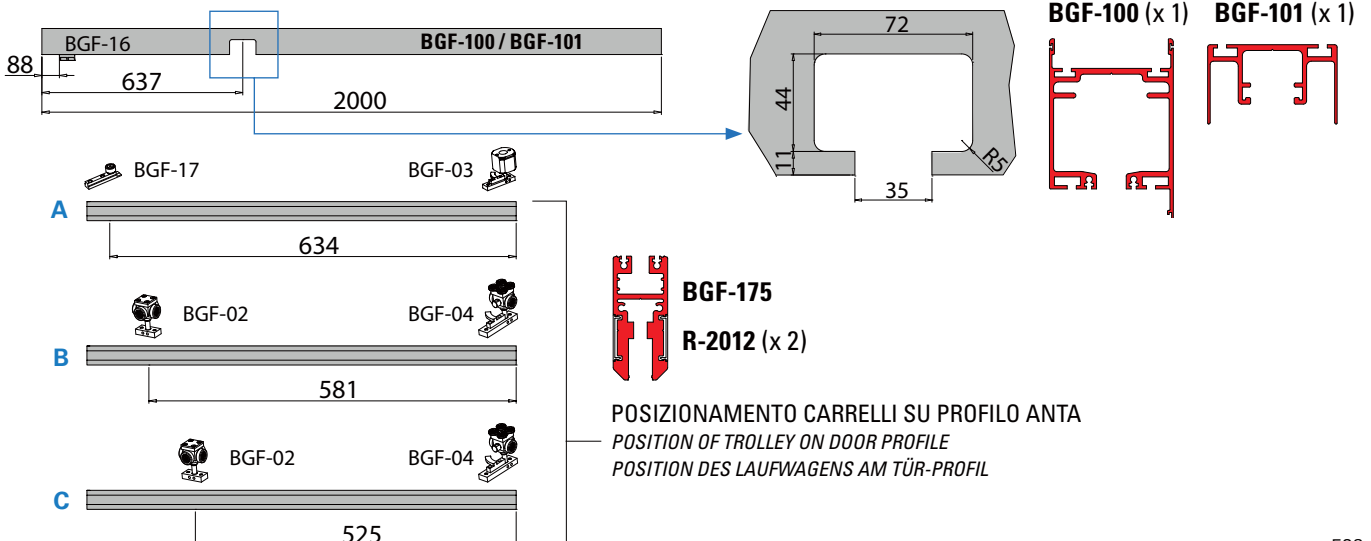



# BALCONGLAS FALCE PARK-70

## COME ASSEMBLARE LE ANTE / HOW TO ASSEMBLE THE DOORS / WIE DIE TÜREN ZUSAMMENSETZT WERDEN

TAGLIO PROFILI PROFIL PREPARATION / PROFILBEARBEITUNG	KIT ACCESSORI ACCESSORY SETS / ZUBEHÖR SETS	ANTA COMPLETA COMPLETE DOOR / KOMPLETTE TÜR
--	--	--

**ANT A / DOOR A / TÜRA**

**SUPERIORE + INFERIORE / TOP + BOTTOM / OBEN + UNTEN**

BGF-175 (x 2) + R-2012 (x 4)

**BGF-PAR-A-DX-8 / BGF-PAR-A-DX-8 (for glass 8 mm)**  
**BGF-PAR-A-DX-10 / BGF-PAR-A-DX-10 (for glass 10 mm)**  
 PORTA LATERALE A / LATERAL PIVOT DOOR A / DREHFLÜGEL A

**ANT B / DOOR B / TÜRB**

**SUPERIORE + INFERIORE / TOP + BOTTOM / OBEN + UNTEN**

BGF-175 (x 2) + R-2012 (x 4)

**BGF-PAR-B-DX-8 / BGF-PAR-B-DX-8 (for glass 8 mm)**  
**BGF-PAR-B-DX-10 / BGF-PAR-B-DX-10 (for glass 10 mm)**  
 ANTA INTERMEDIA B / INTERMEDIATE PANEL B / MITTIGE FLÜGEL B

**ANT C / DOOR C / TÜRC**

**SUPERIORE + INFERIORE / TOP + BOTTOM / OBEN + UNTEN**

BGF-175 (x 2) + R-2012 (x 4)

**BGF-PAR-C-DX-8 / BGF-PAR-C-DX-8 (for glass 8 mm)**  
**BGF-PAR-C-DX-10 / BGF-PAR-C-DX-10 (for glass 10 mm)**  
 ULTIMA ANTA C / LAST PANEL C / ENDFLÜGEL C

# BALCONGLAS FALCE-70B

€ C.324

PROFILO FERMAVETRO BASSO H 64 MM / CLAMPING PROFILE H 64 MM / KLEMMPROFIL H 64 MM

• Sistema a pannelli mobili in vetro, impacchettabili senza la baia di parcheggio, con guida a terra, con profili anta con fori nel vetro.

• Slide and turn system, with floor channel and without parking bay, panels with holes in the glass.

• Schiebe-Dreh-System mit beweglichen Glasmodulen, mit Glasbohrungen, mit Bodenführung und ohne Parkraum.

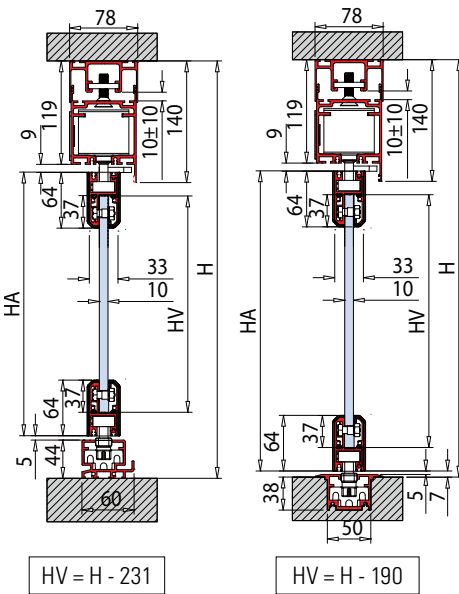
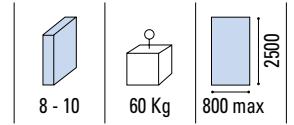

- Canalina incassata BGM-110
- Recessed floor profile BGM-110
- Versenkte Bodenschiene BGM-110

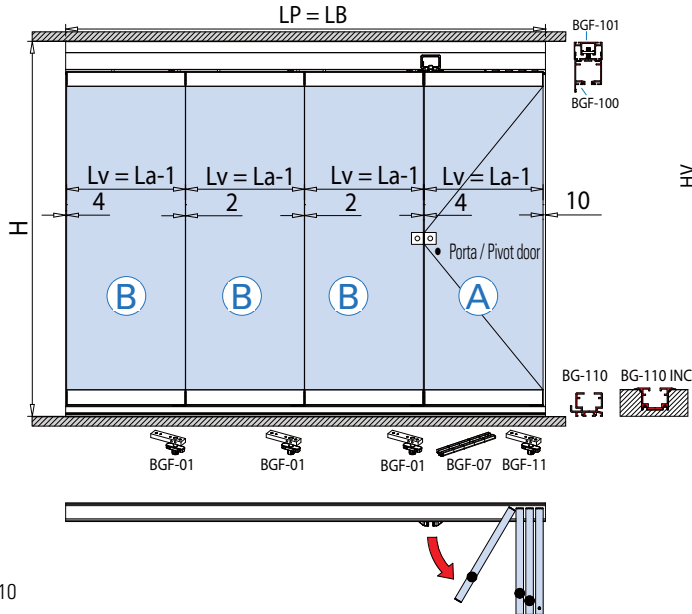

LAVORAZIONE VETRO  
GLASS PREPARATION  
GLASBEARBEITUNG

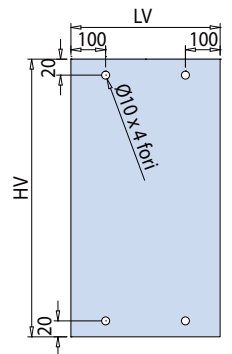

SISTEMI BALCONGLAS  
BALCONGLAS SYSTEMS

- Indicare sempre il verso di apertura e lo spessore vetro
- Please specify always opening direction and glass thickness
- Bitte immer Öffnungsrichtung und Glasdicke angeben

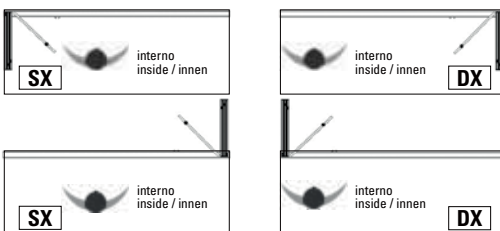

- (A) Porta laterale
- Pivot door
- Seitentür

- (B) Anta intermedia scorrevole
- Intermediate folding panel
- Mittiges Faltelement

BGF-B-SET 2 (LB MAX = 2000 mm)	(A)(B)
BGF-B-SET 3 (LB MAX = 3000 mm)	(A)(B)(B)
BGF-B-SET 4 (LB MAX = 4000 mm)	(A)(B)(B)(B)
BGF-B-SET 5 (LB MAX = 5000 mm)	(A)(B)(B)(B)(B)
BGF-B-SET 6 (LB MAX = 6000 mm)	(A)(B)(B)(B)(B)(B)
BGF-B-SET 7 (LB MAX = 6000 mm)	(A)(B)(B)(B)(B)(B)(B)

# BALCONGLAS FALCE PARK-70B

PROFILO FERMAVETRO BASSO H 64 MM / CLAMPING PROFILE H 64 MM / KLEMMPROFIL H 64 MM

- Sistema a pannelli mobili in vetro, impacchettabili senza guida a terra e senza baia di parcheggio, con profili anta con fori nel vetro.

- Slide and turn system, without floor channel and without parking bay, panels with holes in the glass.

- Schiebe-Dreh-System mit beweglichen Glasmodulen, ohne Bodenführung und ohne Parkraum, mit Glasbohrungen.



8 - 10



60 Kg



800 max

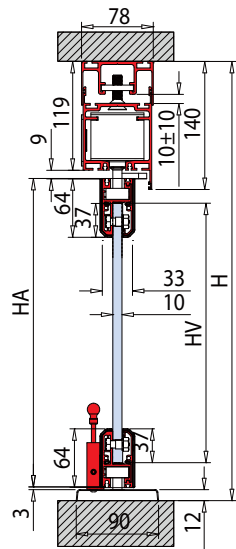

$$HV = H - 198$$

- Siliconare
- Glass to be glued
- Glas kleben

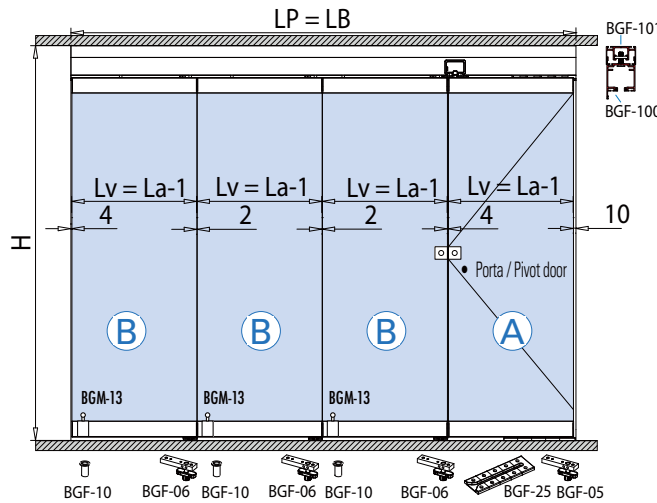
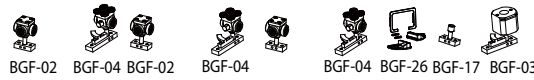
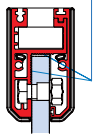

LAVORAZIONE VETRO  
GLASS PREPARATION  
GLASBEARBEITUNG

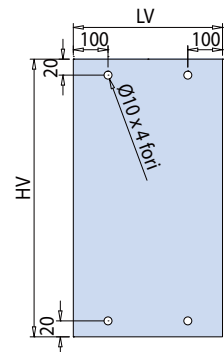

- Indicare sempre il verso di apertura e lo spessore vetro
- Please specify always opening direction and glass thickness
- Bitte immer Öffnungsrichtung und Glasdicke angeben

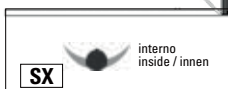
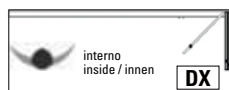

- Ⓐ Porta laterale
- Pivot door
- Seitentür

- Ⓑ Anta intermedia scorrevole
- Intermediate folding panel
- Mittiges Faltelement

BGF-B-PARK SET 2 (LB MAX = 2000 mm)	Ⓐ Ⓑ
BGF-B-PARK SET 3 (LB MAX = 3000 mm)	Ⓐ Ⓑ Ⓑ
BGF-B-PARK SET 4 (LB MAX = 4000 mm)	Ⓐ Ⓑ Ⓑ Ⓑ
BGF-B-PARK SET 5 (LB MAX = 5000 mm)	Ⓐ Ⓑ Ⓑ Ⓑ Ⓑ
BGF-B-PARK SET 6 (LB MAX = 6000 mm)	Ⓐ Ⓑ Ⓑ Ⓑ Ⓑ Ⓑ
BGF-B-PARK SET 7 (LB MAX = 6000 mm)	Ⓐ Ⓑ Ⓑ Ⓑ Ⓑ Ⓑ Ⓑ

# BALCONGLAS FALCE-ISO

€ ▶ C.326

SISTEMA CON CANALINA / SYSTEMS WITH BOTTOM GUIDE / SYSTEM MIT BODENFÜHRUNG

- Sistema a pannelli mobili in vetro, impacchettabili senza la baia di parcheggio, con canalina a terra, con profili per anta intelaiata, misure standard per anta max 1000 x 3000 mm da tagliare cliente.
- Slide and turn system, with floor channel and without parking bay, with profiles for framed glass door, standard measures up to 1000 x 3000 mm, cut by installer.
- Schiebe-Dreh-Systeme mit beweglichen Glasmodulen ohne Parkraum, mit Bodenschiene. Flügelrahmen für standard Tür max 1000 x 3000 mm. Schnitt bauseitig



- Indicare sempre il verso di apertura e lo spessore vetro
- Please specify always opening direction and glass thickness
- Bitte immer Öffnungsrichtung und Glasdicke angeben

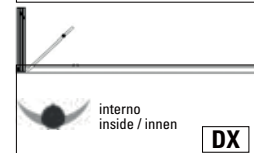
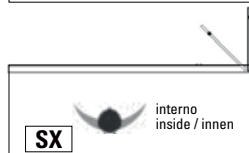
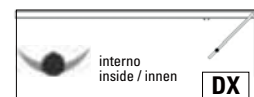
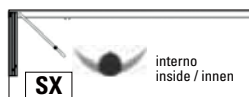

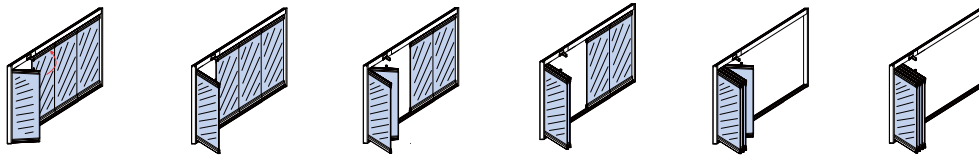

3,3-14-3,3	70 Kg	800 max
------------	-------	---------

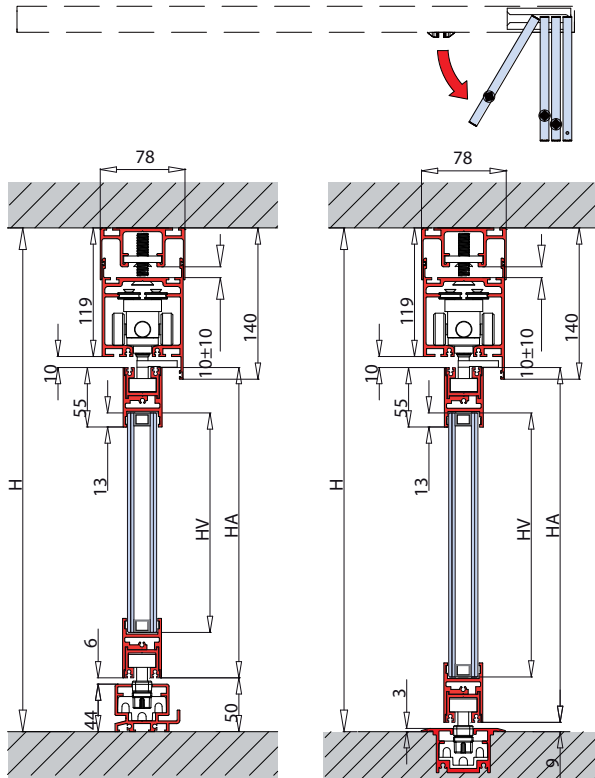

HV = H-263

HV = H-222

- Canalina incassata BGM-110
- Recessed floor profile BGM-110
- Versenkte Bodenschiene BGM-110

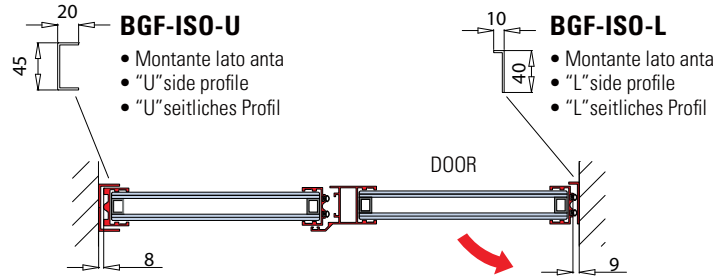

- Con i montanti calcolare 6 mm in più di aria.
- With side profiles to calculate 6 mm extra clearances.
- Mit seitlicher Profile 6 mm extra Spalt zu berechnen.

BG-ISO-SET 2 (LB MAX = 2000 mm)	A B
BG-ISO-SET 3 (LB MAX = 3000 mm)	A B C
BG-ISO-SET 4 (LB MAX = 4000 mm)	A B C C
BG-ISO-SET 5 (LB MAX = 5000 mm)	A B C C C
BG-ISO-SET 6 (LB MAX = 6000 mm)	A B C C C C

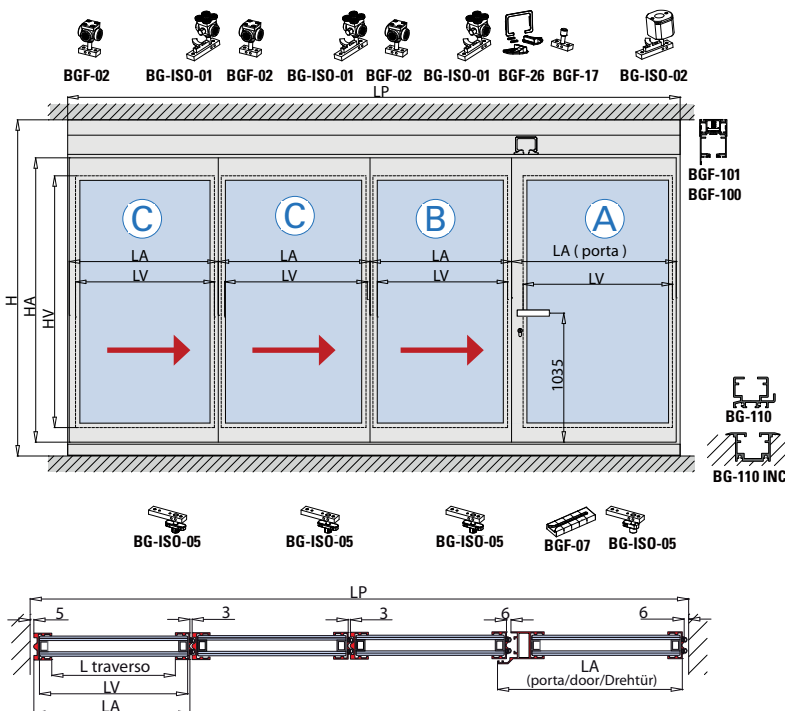

- Lavorazione montante porta per serratura.
- Vertical door Profile preparation for lock.
- Drehtür Profilbearbeitung für Schloss.
- Lavorazione montante anta per contro-serratura.
- Vertical sliding panel preparation for lock's strike plate.
- Schiebeflügel Profilbearbeitung für Schliesblech.

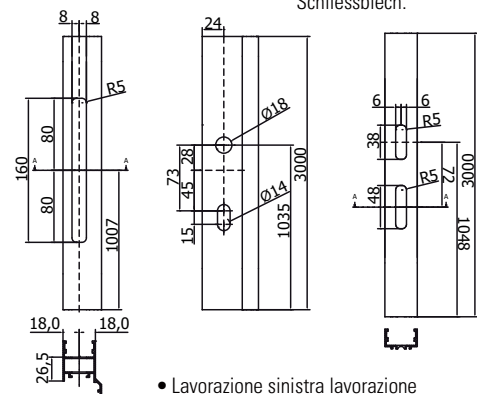

- Lavorazione sinistra lavorazione speculare per la porta destra.
- Left. For right reflecting preparation.
- Links. Für rechts spiegelbildliche Bearbeitung.

**LP**  
Passaggio luce  
Clear opening width  
Lichte Durchgangsbreite

**LA = LV**  
Larghezza ante = Larghezza vetro  
Panel width = Glass width  
Flügelbreite = Glasbreite

**H**  
Altezza passaggio luce  
Clear opening height  
Lichte durchgangshöhe

**HV**  
Altezza vetro  
Glass height  
Glashöhe

**HA**  
Altezza anta  
Door height  
Tür Höhe

xme426

# BALCONGLAS FALCE-ISO

**COME USARE MY METALGLAS / HOW TO USE MY METALGLAS / WIE MAN BENUTZT MY METALGLAS**

**1**

INSERIRE LE MISURE DEL TUO VANO E LE ANTE DESIDERATE  
ENTER THE MEASUREMENTS OF YOUR OPENING AND THE DOORS YOU REQUIRE  
GEBEN SIE DIE MASSE IHRER ÖFFNUNG EIN UND DIE ERFORDERLICHEN TÜREN

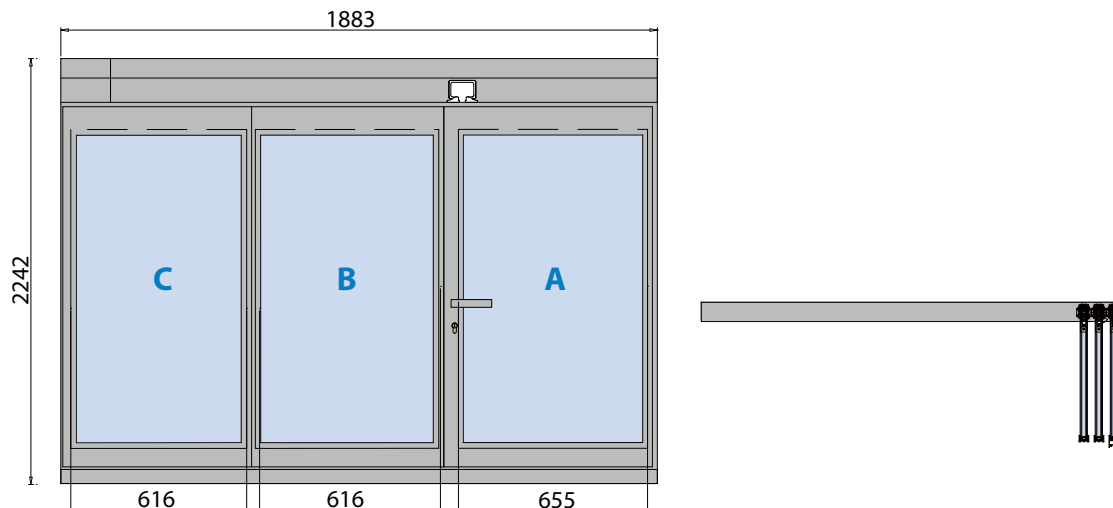

**2**

SI OTTENGONO LE MISURE DEI VETRI AUTOMATICAMENTE  
THE MEASUREMENTS OF THE GLASS WILL BE GENERATED AUTOMATICALLY  
DIE ABMESSUNGEN DES GLASES WERDEN AUTOMATISCH BERECHNET

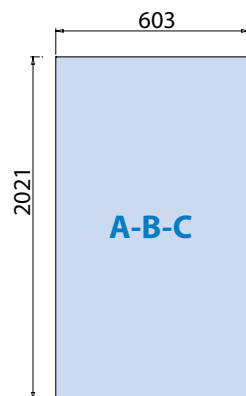

**3**

SI OTTENGONO LE DISTINTE DI TAGLIO DEI PROFILI, DA ABBINARE AGLI ACCESSORI  
THE CUTTING SPECIFICATIONS OF THE PROFILES ARE OBTAINED, FOR MATCHING WITH THE ACCESSORIES  
SIE ERHALTEN EINE SPEZIFIKATION DER PROFILLÄNGEN ZUM ABGLEICHEN MIT DEM ZUBEHÖR

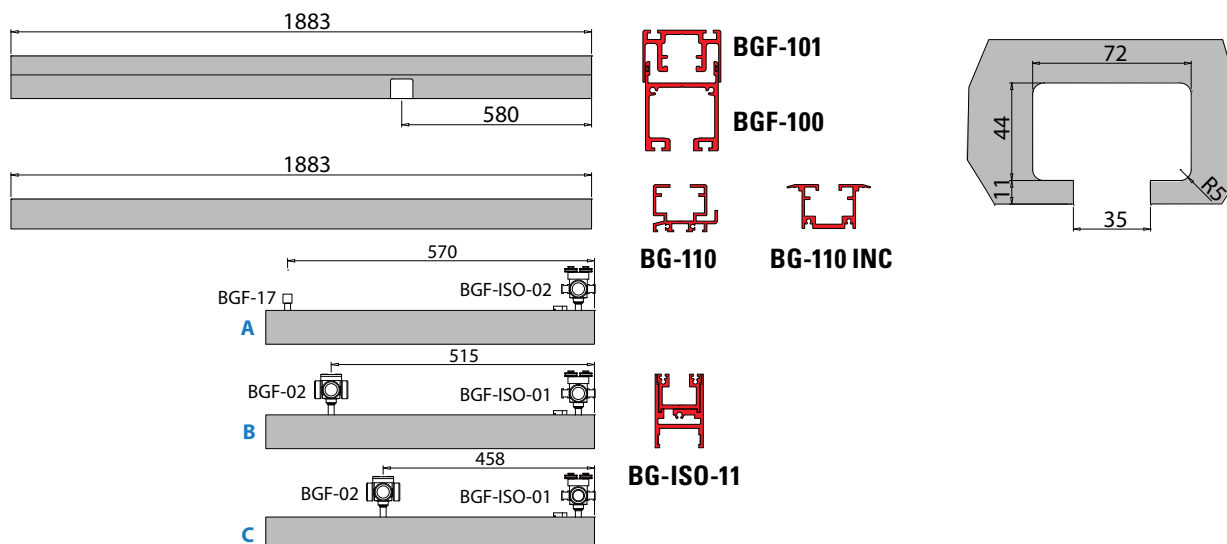

# BALCONGLAS FALCE-ISO

## COME ASSEMBLARE LE ANTE / HOW TO ASSEMBLE THE DOORS / WIE DIE TÜREN ZUSAMMENSETZT WERDEN

**TAGLIO PROFILI**  
PROFIL PREPARATION / PROFILBEARBEITUNG

**KIT ACCESSORI**  
ACCESSORY SETS / ZUBEHÖR SETS

**ANTA COMPLETA**  
COMPLETE DOOR / KOMPLETTE TÜR

**ANTA A / DOOR A / TÜRA**

**BG-ISO-ANT-A-DX / BG-ISO-ANT-A-SX**  
PORTA LATERALE A  
LATERAL PIVOT DOOR A  
DREHFLÜGEL A

**ANTA B / DOOR B / TÜRB**

**BG-ISO-ANT-B-DX / BG-ISO-ANT-B-SX**  
ANTA INTERMEDIA B  
INTERMEDIATE PANEL B  
MITTIGE FLÜGEL B

**ANTA C / DOOR C / TÜRC**

**BG-ISO-ANT-C-DX / BG-ISO-ANT-C-SX**  
ULTIMA ANTA C  
LAST PANEL C  
ENDFLÜGEL C

## BALCONGLAS FALCE PARK-ISO

€ ▶ C.327

SISTEMA SENZA CANALINA / SYSTEMS WITHOUT BOTTOM GUIDE / SYSTEM OHNE BODENFÜHRUNG

- Sistema a pannelli mobili in vetro, impacchettabili senza la baia di parcheggio, senza canalina a terra, con profili per anta intelaiata, misure standard per anta max 1000 x 3000 mm da tagliare cliente.
- Slide and turn system, without floor channel and without parking bay, with profiles for framed glass door, standard measures up to 1000 x 3000 mm, cut by installer.
- Schiebe-Dreh-Systeme mit beweglichen Glasmodulen ohne Parkraum, ohne Bodenschiene. Flügelrahmen für standard Tür max 1000 x 3000 mm. Schnitt bauseitig



- Indicare sempre il verso di apertura e lo spessore vetro
- Please specify always opening direction and glass thickness
- Bitte immer Öffnungsrichtung und Glasdicke angeben

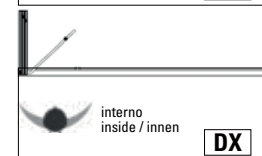
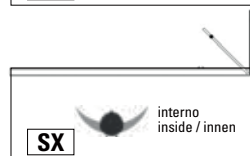
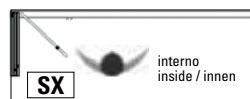



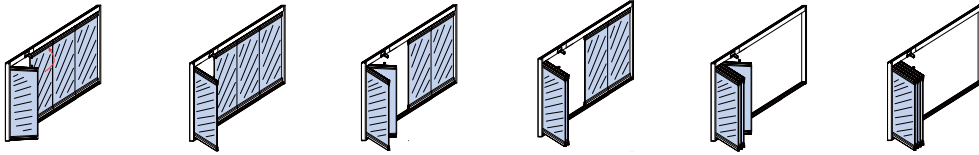

3,3-14-3,3	70 Kg	800 max
------------	-------	---------

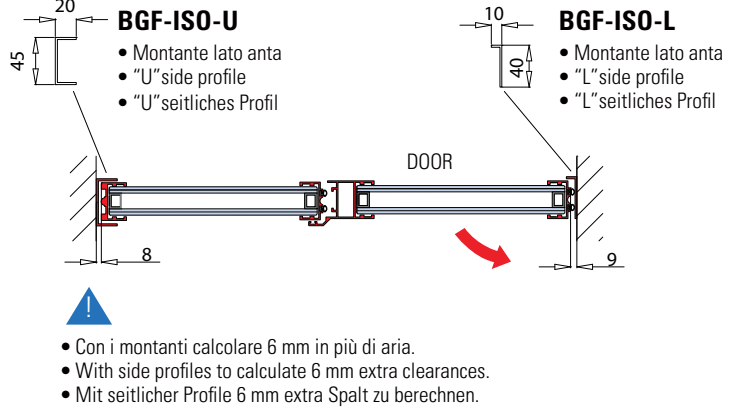
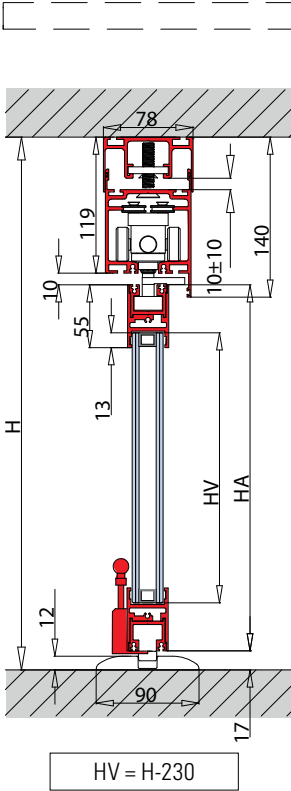
**BGF-10**

BG-ISO-PARK 2 (LB MAX = 2000 mm)	A B
BG-ISO-PARK 3 (LB MAX = 3000 mm)	A B C
BG-ISO-PARK 4 (LB MAX = 4000 mm)	A B C C
BG-ISO-PARK 5 (LB MAX = 5000 mm)	A B C C C
BG-ISO-PARK 6 (LB MAX = 6000 mm)	A B C C C C

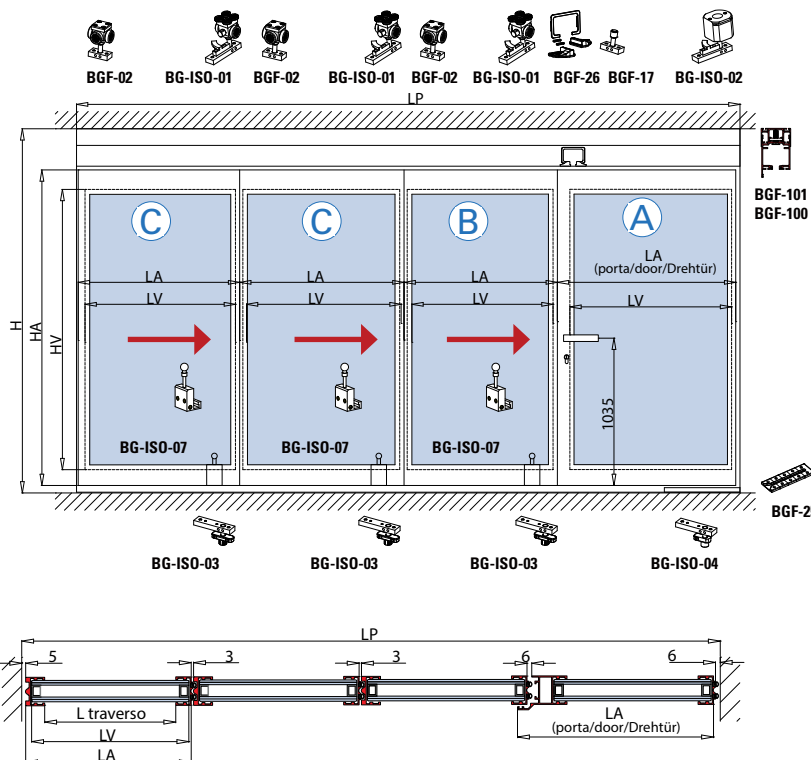

- Lavorazione montante porta per serratura.
- Vertical door Profile preparation for lock.
- Drehtür Profilbearbeitung für Schloss.
- Lavorazione montante anta per contro-serratura.
- Vertical sliding panel preparation for lock's strike plate.
- Schiebeflügel Profilbearbeitung für Schliessblech.

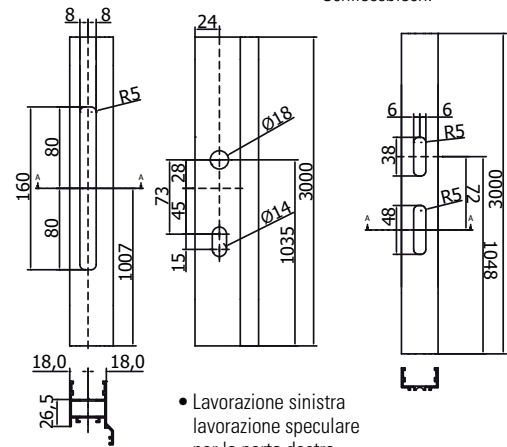

- Lavorazione sinistra lavorazione speculare per la porta destra.
- Left. For right reflecting preparation.
- Links. Für rechts spiegelbildliche Bearbeitung.

**LP**  
 Passaggio luce  
 Clear opening width  
 Lichte Durchgangsbreite

**LA = LV**  
 Larghezza ante = Larghezza vetro  
 Panel width = Glass width  
 Flügelbreite = Glasbreite

**H**  
 Altezza passaggio luce  
 Clear opening height  
 Lichte durchgangshöhe

**HV**  
 Altezza vetro  
 Glass height  
 Glashöhe

**HA**  
 Altezza anta  
 Door height  
 Tür Höhe

# BALCONGLAS FALCE PARK-ISO

**COME USARE MY METALGLAS / HOW TO USE MY METALGLAS / WIE MAN BENUTZT MY METALGLAS**

**1**

INSERIRE LE MISURE DEL TUO VANO E LE ANTE DESIDERATE  
ENTER THE MEASUREMENTS OF YOUR OPENING AND THE DOORS YOU REQUIRE  
GEBEN SIE DIE MASSE IHRER ÖFFNUNG EIN UND DIE ERFORDERLICHEN TÜREN

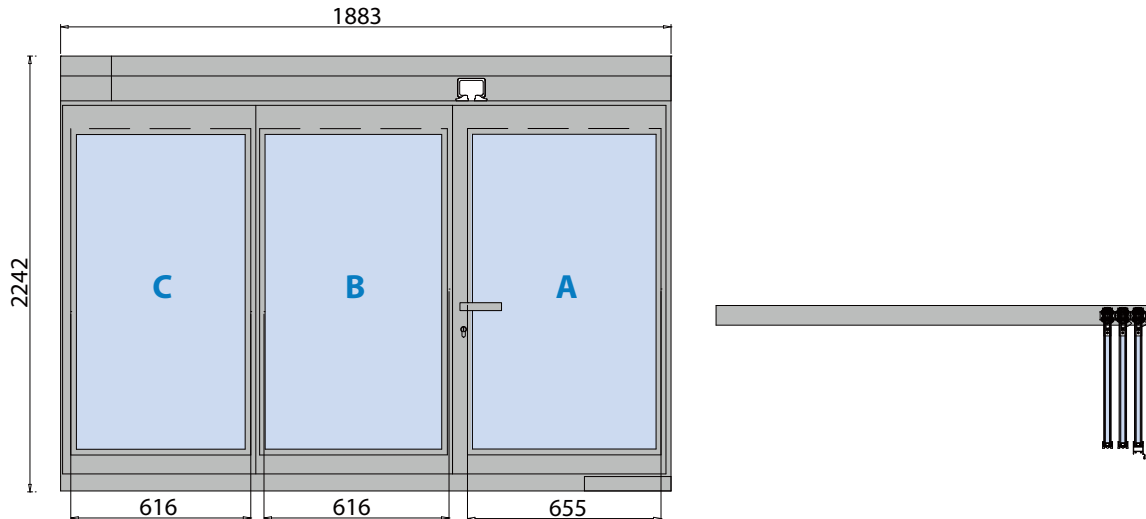

**2**

SI OTTENGONO LE MISURE DEI VETRI AUTOMATICAMENTE  
THE MEASUREMENTS OF THE GLASS WILL BE GENERATED AUTOMATICALLY  
DIE ABMESSUNGEN DES GLASES WERDEN AUTOMATISCH BERECHNET

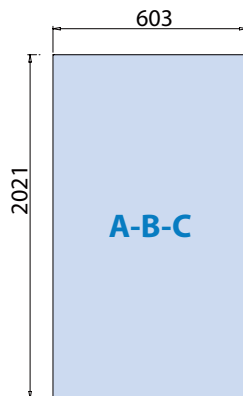

**3**

SI OTTENGONO LE DISTINTE DI TAGLIO DEI PROFILI, DA ABBINARE AGLI ACCESSORI  
THE CUTTING SPECIFICATIONS OF THE PROFILES ARE OBTAINED, FOR MATCHING WITH THE ACCESSORIES  
SIE ERHALTEN EINE SPEZIFIKATION DER PROFILLÄNGEN ZUM ABGLEICHEN MIT DEM ZUBEHÖR

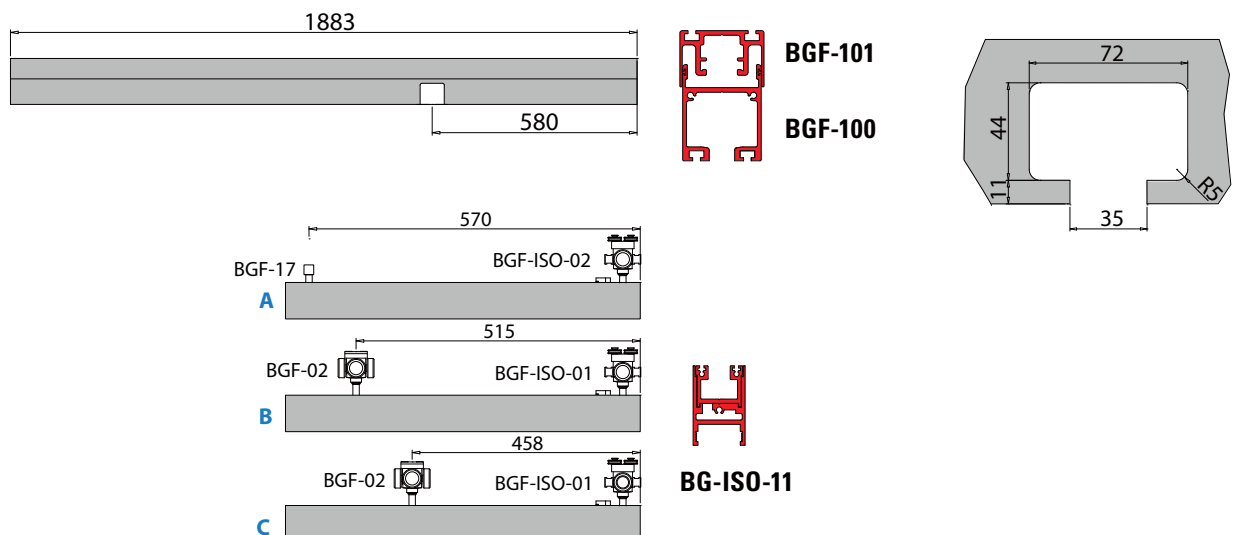

# BALCONGLAS FALCE PARK-ISO

COME ASSEMBLARE LE ANTE / HOW TO ASSEMBLE THE DOORS / WIE DIE TÜREN ZUSAMMENGESSETZT WERDEN

TAGLIO PROFILI PROFIL PREPARATION / PROFILBEARBEITUNG	KIT ACCESSORI ACCESSORY SETS / ZUBEHÖR SETS	ANTA COMPLETA COMPLETE DOOR / KOMPLETTE TÜR
--	--	--

**ANTA A / DOOR A / TÜR A**

**BG-ISO-PAR-A-DX / BG-ISO-PAR-A-SX**  
 PORTA LATERALE A  
 LATERAL PIVOT DOOR A  
 DREHFLÜGEL A

**ANTA B / DOOR B / TÜR B**

**BG-ISO-PAR-B-DX / BG-ISO-PAR-B-SX**  
 ANTA INTERMEDIA B  
 INTERMEDIATE PANEL B  
 MITTIGE FLÜGEL B

**ANTA C / DOOR C / TÜR C**

**BG-ISO-PAR-C-DX / BG-ISO-PAR-C-SX**  
 ULTIMA ANTA C  
 LAST PANEL C  
 ENDFLÜGEL C

## ACCESSORI PER SISTEMI A LIBRO - PARCHEGGIO

ACCESSORIES FOR FOLDING - STACKING SYSTEMS / ZUBEHÖRE FALT - SCHIEBEWÄNDE-SYSTEME



- Esempi di serrature e maniglioni possibili.  
Per altri modelli consultare il catalogo Metalglas Indoor.
- Examples of possible locks and pullhandles.  
For other models, check the Metalglas Indoor catalog
- Beispiele von Schlössern und Stossgriffe.  
Für andere Modelle siehe Metalglas Indoor Katalog.

**V-750 PZ**



**V-504-NG**



**V-720 PZ**



**V-900 PZ (AN / IX)**



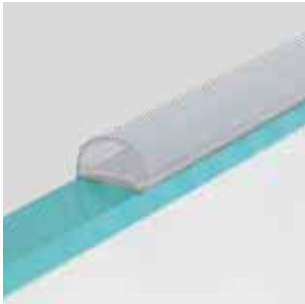
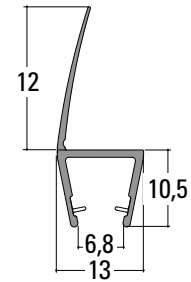

**V-039**

- Guarnizione con aletta per vetro 8-10 mm
- Gasket with wing for glass 8-10 mm
- Dichtung mit Lippe für Glasdicke 8-10 mm

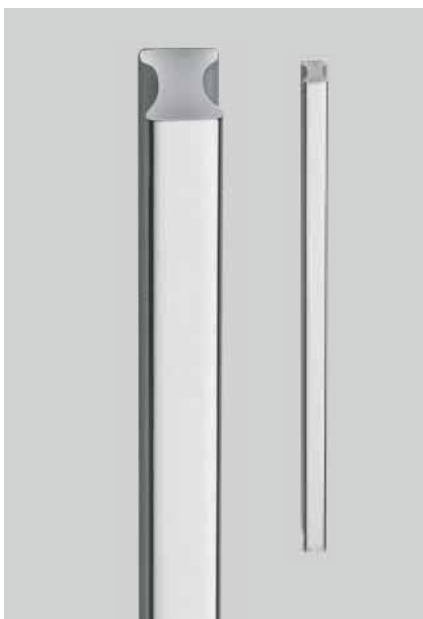
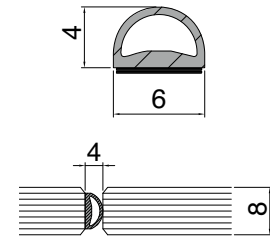

**WRU-C-BUMP-MT12**

- Guarnizione neutra per vetro 8 mm, fissaggio adesivo
- Neutral gasket for glass 8 mm with adhesive fixing
- Dichtungsprofil für 8 mm Glaskante selbstklebend

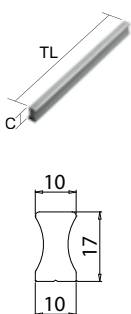

**POR-0408 V**

€► F.37

- Maniglione alluminio senza fori nel vetro ad incollaggio con biadesivo 3M
- Pullhandle in aluminium without holes in glass fixing with 3M self-adhesive
- Stossgriffe aus Aluminium ohne Glasbearbeitung selbstklebend

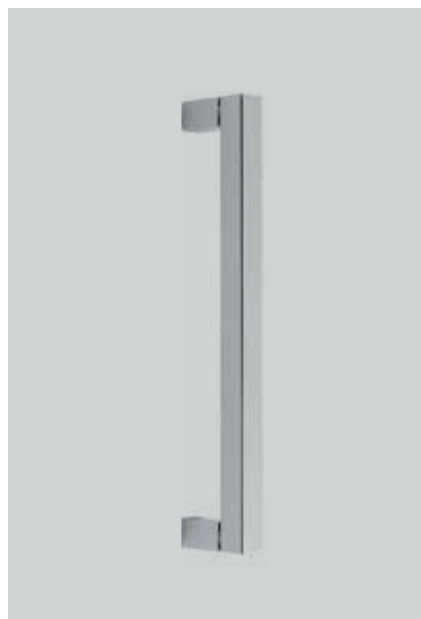

TL	C	Unit.	Finitura Finishes Oberfläche
260	17	Singolo Piece Stück	AN
			CR
			NS
410	17	Singolo Piece Stück	AN
			CR
			NS
560	17	Singolo Piece Stück	AN
			CR
			NS

**SQUARE Alu  $\varnothing$  14**

€► F.40

- Maniglione. Materiale: Alluminio
  - Pullhandle. Material: Aluminium
  - Stossgriff. Material: Aluminium
- AN - CR

TL	174	206	334	
160	•			$\varnothing$ 8,5
<b>A</b> 192		•		$\varnothing$ 8,5
320			•	$\varnothing$ 8,5

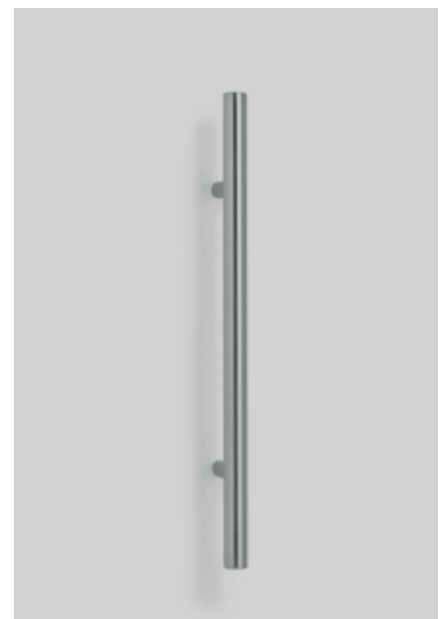
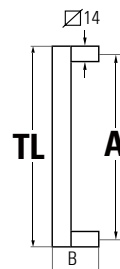
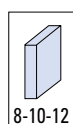
**ROUND 02**

€► F.46

- Maniglione
  - Pullhandle
  - Stossgriff
- IX

$\varnothing$	A	200	300	500	650	1000	1040	1370	
20		•	•	•	•				$\varnothing$ 10
25			•	•	•				$\varnothing$ 12
30				•	•		•		$\varnothing$ 12



## LOGGIAGLAS

LOGGIAGLAS

LOGGIAGLAS

Sistema scorrevole telescopico studiato per balconi, logge e verande  
*Telescopic sliding system for balconies, loggias and terraces / Teleskop Schiebetürsystem für Balkon und Loggiaverglasungen*





- LOGGIAGLAS LG-500 SET 2 ▶ 152**
- LOGGIAGLAS LG-500 SET 3 ▶ 154**
- LOGGIAGLAS LG-500 SET 4 ▶ 156**
- LOGGIAGLAS LG-500 SET 5 ▶ 158**

- LOGGIAGLAS LG-400 SET 2 ▶ 168**
- LOGGIAGLAS LG-400 SET 3 ▶ 170**
- LOGGIAGLAS LG-400 SET 4 ▶ 172**
- LOGGIAGLAS LG-400 SET 5 ▶ 174**

- Sistema scorrevole telescopico studiato per balconi, logge e verande, ideale per proteggersi da vento e intemperie. Sistema con guida a terra.
- Telescopic sliding system for balcony, Loggia and terrace, ideal for wind and weather protection. System with bottom guide.
- Teleskop Schiebetürsystem für Balkon und Loggiaverglasungen, ideal für Wind-und Wetterschutz. System mit Bodenführung.

### LG-500 SET 2

- Sistema 2 ante telescopiche
- System for 2 telescopic doors
- System mit 2 Teleskoptüren

### LG-500 SET 3

- Sistema 3 ante telescopiche
- System for 3 telescopic doors
- System mit 3 Teleskoptüren

### LG-500 SET 4

- Sistema 4 ante telescopiche
- System for 4 telescopic doors
- System mit 4 Teleskoptüren

### LG-500 SET 5

- Sistema 5 ante telescopiche
- System for 5 telescopic doors
- System mit 5 Teleskoptüren

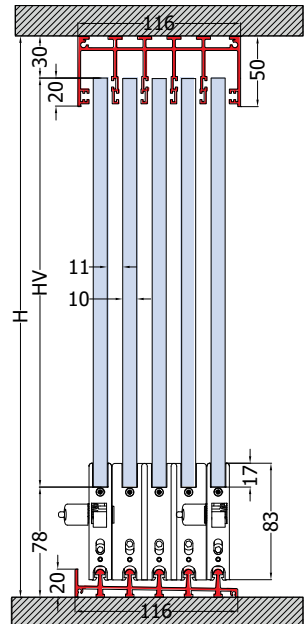
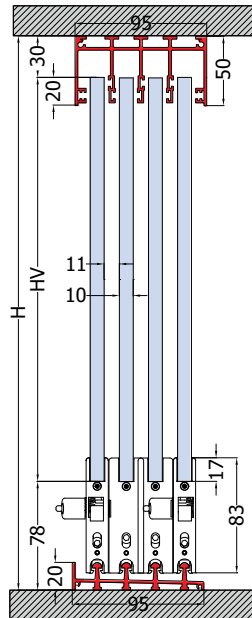
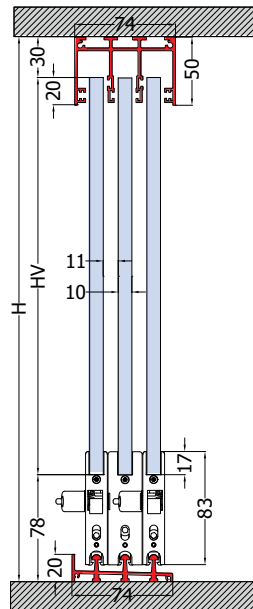
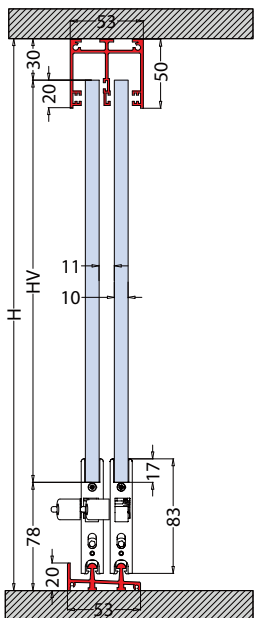

- Possibilità di installare guida a terra incassata nel pavimento
- Ability to install a similar rail embedded in the floor
- Möglichkeit eine Führungsschiene in den Boden einzubauen

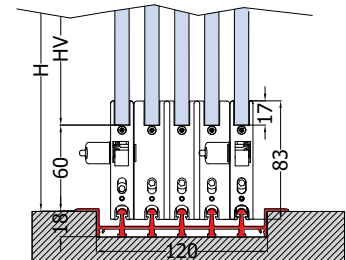
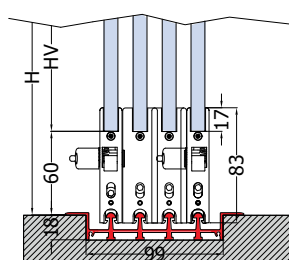
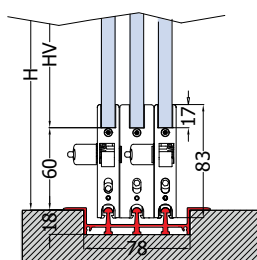
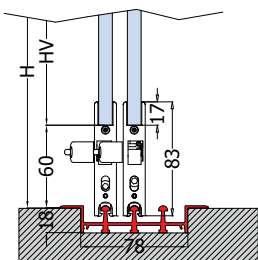

## LOGGIAGLAS LG-500 4x4

### INNOVAZIONE AL QUADRATO

Il nuovo carrello è un'insieme di innovazione e tecnologia.

Doppia ruota, con cuscinetto a sfera, montata su bilanciere che ne consente l'aderenza contemporanea al binario, rendendo lo scorrimento estremamente fluido.

#### INNOVATION<sup>2</sup>

*The new trolley is a blend of innovation and technology. Double wheel, with ball bearing, mounted on a rocker arm that allows its simultaneous adherence to the track, making sliding extremely fluid.*

#### INNOVATION<sup>2</sup>

*Der neue Wagen ist eine Kombination aus Innovation und Technologie. Zwei Räder mit Kugellager, montiert auf einer Wippe, die das gleichzeitige Aufliegen auf der Schiene garantiert. Dadurch wird die Schiebewegung besonders fließend.*

# PLUS

PATENT  
PENDING



**6** Antisollevamento delle ante integrato nel carrello per una sicurezza assoluta ed una semplicità di rimozione, nel caso di manutenzione, grazie al nuovo brevetto Metalglas.

*Anti-lifting doors integrated into the trolley for absolute safety and easy removal, in the event of maintenance, thanks to the new Metalglas patent.*

*Im Wagen ist ein System integriert, das ein Anheben der Türen verhindert. Es sorgt für absolute Sicherheit und garantiert ein einfaches Entfernen für die Wartung.*

*Dies ist dem neuen Patent von Metalglas zu verdanken.*







LG-500			
100 Kg	10	1200	3000
LG-500-12			
100 Kg	12	1000	3000

**1** Due ruote per carrello vuol dire quattro ruote per anta e quindi spazio alle dimensioni. Libertà di applicazione per poter arrivare fino a 100 Kg di vetro.

*Two wheels per trolley means four wheels per door and therefore, it is appropriate for larger sizes. Freedom of application, making it possible to handle up to 100 kg of glass.*

*Zwei Räder pro Wagen bedeutet vier Räder pro Tür und damit besonders viel Platz. Frei anwendbar für Glas mit einem Gewicht von bis zu 100 kg.*



**2** Il nuovo carrello favorisce inoltre una facile regolazione in altezza delle ante.

*The new trolley also facilitates height adjustment of the doors.*

*Der neue Wagen ermöglicht außerdem das leichte Einstellen der Höhe der Türen.*

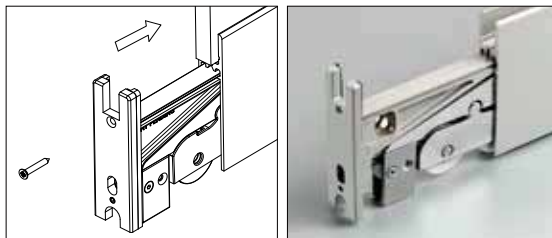

**3** Basta tagliare il profilo a misura ed infilare i due carrelli ed il gioco è fatto. Nessuna lavorazione sui profili per questo sistema fantastico ed innovativo.

*Just cut the profile to size and slide in the two carts, that's it! No further processing is required on the profiles for this fantastic and innovative system.*

*Dazu reicht es aus, das Profil nach Maß zuzuschneiden und die zwei Wagen einzufügen. Schon ist die Arbeit erledigt. Keine Arbeit an den Profilen dank dieses fantastischen und innovativen Systems.*



**4** Mai più destro o sinistro. Un unico accessorio per tutte le tipologie di apertura.

*No longer left or right, a single accessory for all types of openings.*

*Nie mehr rechts oder links - ein einziges Werkzeug für alle Öffnungsrichtungen.*



**5** Un altro vantaggio estetico e tecnico è il catenacciolo integrato nel carrello. Semplicità e velocità di applicazione.

*Another aesthetic and technical advantage is the locking latch integrated into the trolley. Simplicity and speed of application.*

*Ein weiterer ästhetischer und technischer Vorteil besteht im Schließbolzen, der in den Wagen integriert ist. Einfache und schnelle Anwendung.*

# LOGGIAGLAS LG-500 SET 2

SCORREVOLE TELESCOPICO / TELESCOPIC SLIDING SYSTEM / TELESKOP SCHIEBETÜRSYSTEM

€ ▶ C.328

€ ▶ C.329

- SISTEMA CON GUIDA A TERRA:**  
 Sistema scorrevole telescopico studiato per balconi, logge e verande, ideale per proteggersi da vento e intemperie.
- SYSTEMS WITH BOTTOM GUIDE:**  
 Telescopic sliding system for balcony, Loggia and terrace, ideal for wind and weather protection.
- SYSTEM MIT BODENFÜHRUNG:**  
 Teleskop Schiebetürsystem für Balkon und Loggiaverglasungen, ideal für Wind-und Wetterschutz.



## COMPONENTI / COMPONENTS / EINZELTEILE



LG-528



LG-529



LG-503



LG-505



LG-508



LG-509



LG-510



LG-511



LG-519



LG-520

LOGGIAGLAS

LG-500			LG-500-12			
100 Kg	10	1200	100 Kg	12	1000	
4 ruote per anta / 4 wheels each panel / 4 Rollen je Flügel						

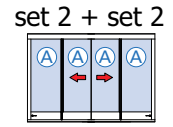
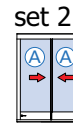
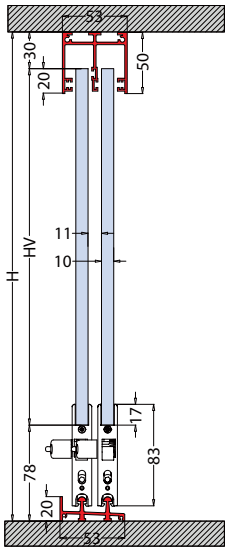
**LG-500 / LG-500-12 / LG-550**

$$HV = H - 108$$

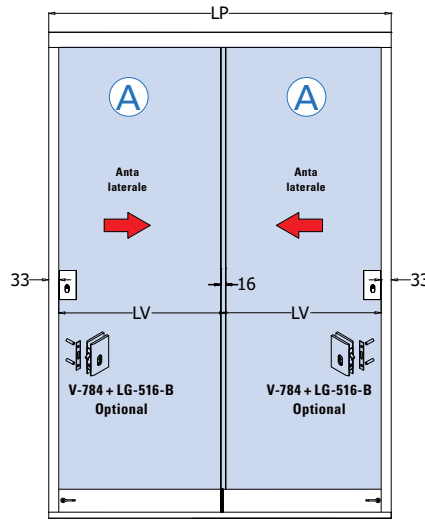
**LG-510 / LG-510-12 / LG-560**

- Set con guida inferiore incassata
- Set with recessed floor profile
- Set mit versenkter Bodenschiene

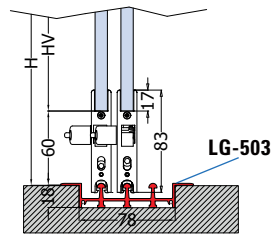

$$HV = H - 90$$

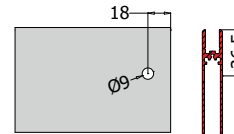
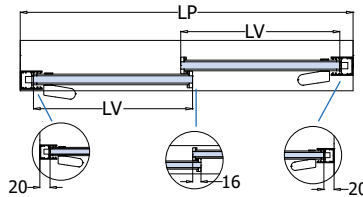

- Lavorazione profilo anta per catenacciolo LG-511 / LG-512
- Preparation panel profile for Locking bolt LG-511 / LG-512
- Profilbearbeitung für Feststellriegel LG-511 / LG-512

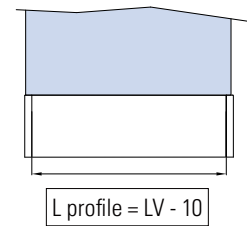

$$L \text{ profile} = LV - 10$$

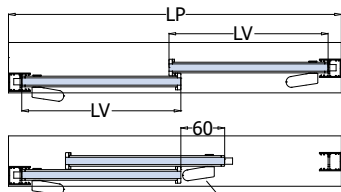

**FORMULE CALCOLO VETRI VEDI PAG 160**  
**CALCULATION GLASS SEE PAGE 160**  
**GLASBERECHNUNG SIEHE SEITE 160**

**LG-500**

- **Sistema di autobilanciamento**  
 Il nostro carrello a bilanciere autoregola la posizione delle 2 ruote in modo da assicurare lo scorrimento contemporaneo delle ruote sul binario
- **Auto balance mechanism**  
 Our seesaw roller system can actively self-adjust the position of the wheels to ensure the wheels are rolling on the rails at the same time
- **Auto balance**  
 Zwei Räder mit Kugellager, montiert auf einer Wippe, die das gleichzeitige Aufliegen auf der Schiene garantiert. Dadurch wird die Schiebewegung besonders fließend.

xme571b

**LP**  
 Passaggio luce  
 Clear opening width  
 Lichte Durchgangsbreite

**LV**  
 Larghezza vetro  
 Glass width  
 Glas Breite

**H**  
 Altezza passaggio luce  
 Clear opening height  
 Lichte Durchgangshöhe

**HV**  
 Altezza vetro  
 Glass height  
 Glas Höhe

**AN**  
 Alluminio anodizzato  
 Aluminium anodized  
 Aluminium Silberfarbig

**BI**  
 Bianco Ral 9010  
 White Ral 9010  
 Weiss Ral 9010

## LOGGIAGLAS LG-500 SET 3

SCORREVOLE TELESCOPICO / TELESCOPIC SLIDING SYSTEM / TELESKOP SCHIEBETÜRSYSTEM

€ ▶ C.328

€ ▶ C.329

• **SISTEMA CON GUIDA A TERRA:**

Sistema scorrevole telescopico studiato per balconi, logge e verande, ideale per proteggersi da vento e intemperie.

• **SYSTEMS WITH BOTTOM GUIDE:**

Telescopic sliding system for balcony, Loggia and terrace, ideal for wind and weather protection.

• **SYSTEM MIT BODENFÜHRUNG:**

Teleskop Schiebetürsystem für Balkon und Loggiaverglasungen, ideal für Wind-und Wetterschutz.



### COMPONENTI / COMPONENTS / EINZELTEILE



LG-501

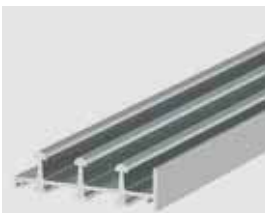

LG-502



LG-503



LG-505



LG-508



LG-509



LG-510



LG-511



LG-519



LG-520

LG-500			LG-500-12			
 100 Kg	 10	 1200 3000	 100 Kg	 12	 1000 3000	
4 ruote per anta / 4 wheels each panel / 4 Rollen je Flügel						

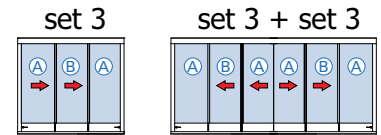
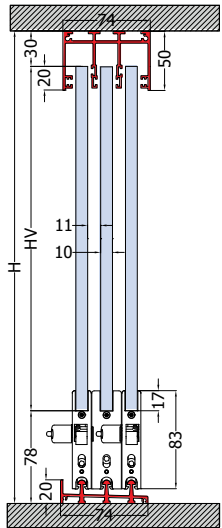
**LG-500 / LG-500-12 / LG-550**

$$HV = H - 108$$

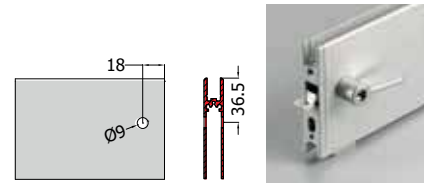
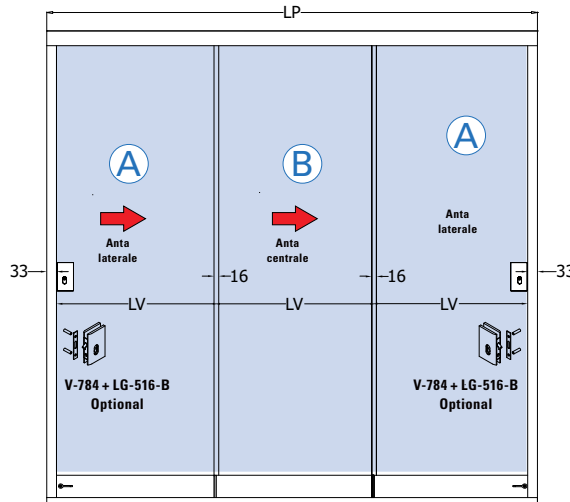

- Lavorazione profilo anta per catenacciolo LG-511 / LG-512.
- Preparation panel profile for Locking bolt LG-511 / LG-512.
- Profilbearbeitung für Feststellriegel LG-511 / LG-512.

**LG-510 / LG-510-12 / LG-560**

- Set con guida inferiore incassata
- Set with recessed floor profile
- Set mit versenkter Bodenschiene

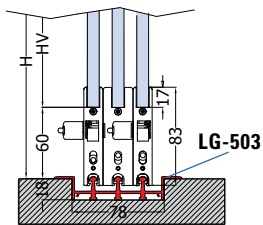

$$HV = H - 90$$

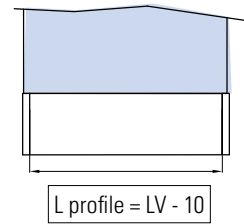
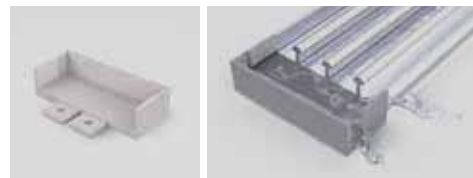
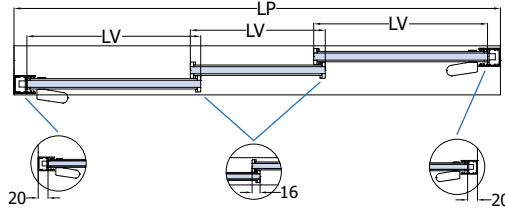

$$L \text{ profile} = LV - 10$$

- Taglio guida a terra =
- Bottom rail length =
- Länge Bodenschiene =

$$LP - 64$$

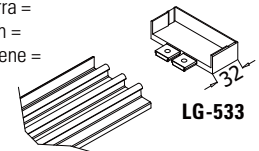
**LG-533 (OPTIONAL)**

- Sistema scarico acqua laterale per la guida inferiore 3 vie
- Side drainage system for 3-ways floor profile
- Seitliches Entwässerungssystem für 3-läufige Bodenschiene

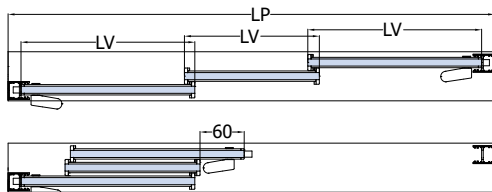
**LG-500**

- *Sistema di autobilanciamento*  
Il nostro carrello a bilanciere autoregola la posizione delle 2 ruote in modo da assicurare lo scorrimento contemporaneo delle ruote sul binario
- *Auto balance mechanism*  
Our seesaw roller system can actively self-adjust the position of the wheels to ensure the wheels are rolling on the rails at the same time
- *Auto balance*  
Zwei Räder mit Kugellager, montiert auf einer Wippe, die das gleichzeitige Aufliegen auf der Schiene garantiert. Dadurch wird die Schiebewegung besonders fließend.

**FORMULE CALCOLO VETRI VEDI PAG 161**  
**CALCULATION GLASS SEE PAGE 161**  
**GLASBERECHNUNG SIEHE SEITE 161**

**LP**  
 Passaggio luce  
 Clear opening width  
 Lichte Durchgangsbreite

**LV**  
 Larghezza vetro  
 Glass width  
 Glas Breite

**H**  
 Altezza passaggio luce  
 Clear opening height  
 Lichte Durchgangshöhe

**HV**  
 Altezza vetro  
 Glass height  
 Glas Höhe

**AN**  
 Alluminio anodizzato  
 Aluminium anodized  
 Aluminium Silberfarbig

**BI**  
 Bianco Ral 9010  
 White Ral 9010  
 Weiss Ral 9010

xme571c

## LOGGIAGLAS LG-500 SET 4

SCORREVOLE TELESCOPICO / TELESCOPIC SLIDING SYSTEM / TELESKOP SCHIEBETÜRSYSTEM

€ ▶ C.328

€ ▶ C.329

- SISTEMA CON GUIDA A TERRA:**  
 Sistema scorrevole telescopico studiato per balconi, logge e verande, ideale per proteggersi da vento e intemperie.
- SYSTEMS WITH BOTTOM GUIDE:**  
 Telescopic sliding system for balcony, Loggia and terrace, ideal for wind and weather protection.
- SYSTEM MIT BODENFÜHRUNG:**  
 Teleskop Schiebetürsystem für Balkon und Loggiaverglasungen, ideal für Wind-und Wetterschutz.



### COMPONENTI / COMPONENTS / EINZELTEILE



LG-500			LG-500-12			
100 Kg	10	1200	100 Kg	12	1000	

4 ruote per anta / 4 wheels each panel / 4 Rollen je Flügel

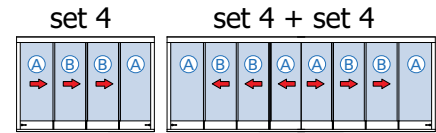
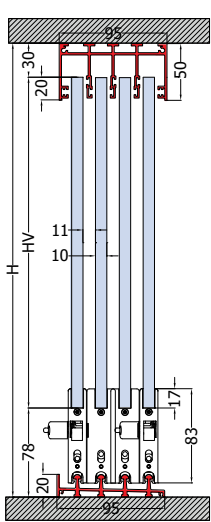
**LG-500 / LG-500-12 / LG-550**

$$HV = H - 108$$

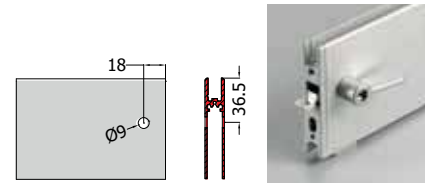
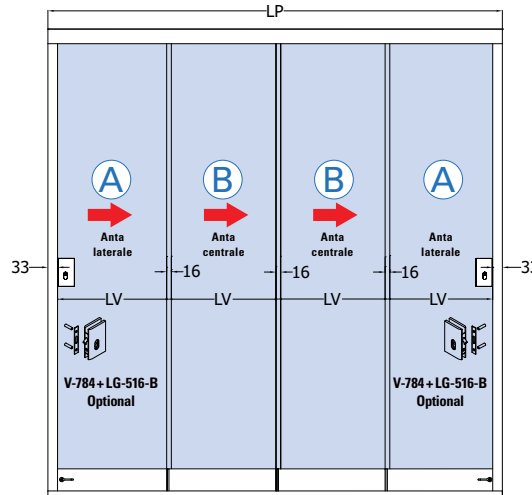

- Lavorazione profilo anta per catenacciolo LG-511 / LG-512.
- Preparation panel profile for Locking bolt LG-511 / LG-512.
- Profilbearbeitung für Feststellriegel LG-511 / LG-512.

**LG-510 / LG-510-12 / LG-560**

- Set con guida inferiore incassata
- Set with recessed floor profile
- Set mit versenkter Bodenschiene

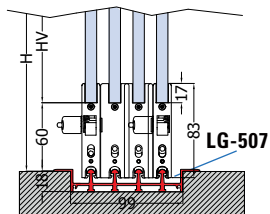

$$HV = H - 90$$

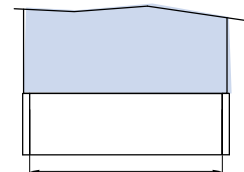
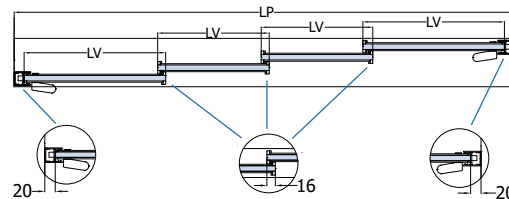

$$L \text{ profile} = LV - 10$$

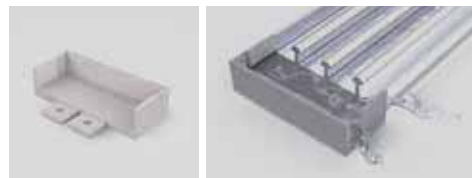

- Taglio guida a terra =
- Bottom rail length =
- Länge Bodenschiene =

$$LP - 64$$

**LG-534**
**LG-534 (OPTIONAL)**

- Sistema scarico acqua laterale per la guida inferiore 4 vie
- Side drainage system for 4-ways floor profile
- Seitliches Entwässerungssystem für 4-läufige Bodenschiene

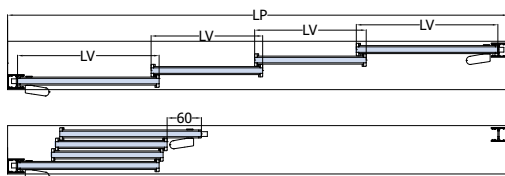
**LG-500**

- **Sistema di autobilanciamento**  
Il nostro carrello a bilanciere autoregola la posizione delle 2 ruote in modo da assicurare lo scorrimento contemporaneo delle ruote sul binario
- **Auto balance mechanism**  
Our seesaw roller system can actively self-adjust the position of the wheels to ensure the wheels are rolling on the rails at the same time
- **Auto balance**  
Zwei Räder mit Kugellager, montiert auf einer Wippe, die das gleichzeitige Aufliegen auf der Schiene garantiert. Dadurch wird die Schiebewegung besonders fließend.

**FORMULE CALCOLO VETRI VEDI PAG 162**  
**CALCULATION GLASS SEE PAGE 162**  
**GLASBERECHNUNG SIEHE SEITE 162**

xme571d

**LP**

Passaggio luce  
Clear opening width  
Lichte Durchgangsbreite

**LV**

Larghezza vetro  
Glass width  
Glas Breite

**H**

Altezza passaggio luce  
Clear opening height  
Lichte Durchgangshöhe

**HV**

Altezza vetro  
Glass height  
Glas Höhe

**AN**

Alluminio anodizzato  
Aluminium anodized  
Aluminium Silberfarbig

**BI**

Bianco Ral 9010  
White Ral 9010  
Weiss Ral 9010

# LOGGIAGLAS LG-500 SET 5

SCORREVOLE TELESCOPICO / TELESCOPIC SLIDING SYSTEM / TELESKOP SCHIEBETÜRSYSTEM

€ ▶ C.328

€ ▶ C.329

• **SISTEMA CON GUIDA A TERRA:**

Sistema scorrevole telescopico studiato per balconi, logge e verande, ideale per proteggersi da vento e intemperie.

• **SYSTEMS WITH BOTTOM GUIDE:**

Telescopic sliding system for balcony, Loggia and terrace, ideal for wind and weather protection.

• **SYSTEM MIT BODENFÜHRUNG:**

Teleskop Schiebetürsystem für Balkon und Loggiaverglasungen, ideal für Wind-und Wetterschutz.



## COMPONENTI / COMPONENTS / EINZELTEILE



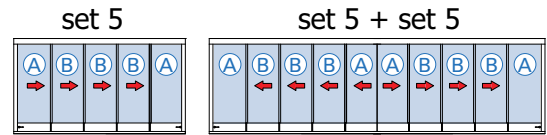
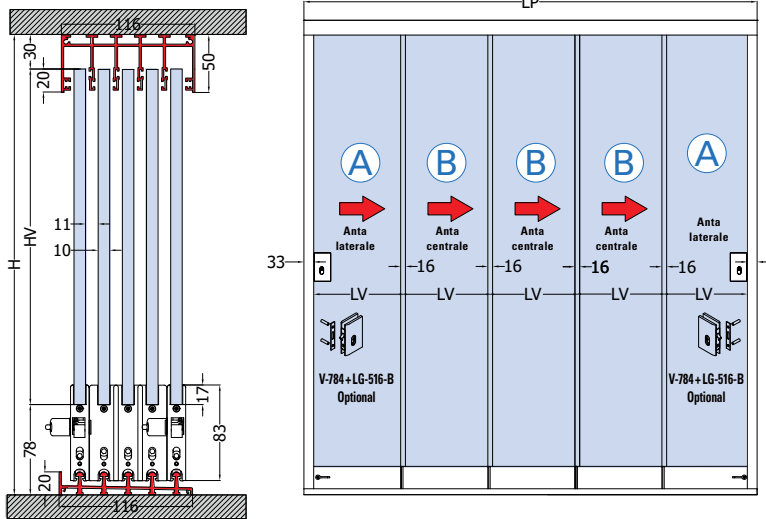

LG-500			LG-500-12			
 100 Kg  10  1200  3000	 10  1200  3000	 12  1000  3000	 100 Kg  12  1000  3000	 12  1000  3000	 10  1200  3000	
4 ruote per anta / 4 wheels each panel / 4 Rollen je Flügel						

**LG-500 / LG-500-12 / LG-550**

$$HV = H - 108$$

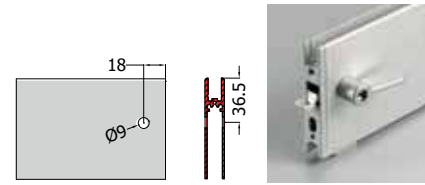

- Lavorazione profilo anta per catenacciolo LG-511 / LG-512.
- Preparation panel profile for Locking bolt LG-511 / LG-512.
- Profilbearbeitung für Feststellriegel LG-511 / LG-512.

**LG-510 / LG-510-12 / LG-560**

- Set con guida inferiore incassata
- Set with recessed floor profile
- Set mit versenkter Bodenschiene

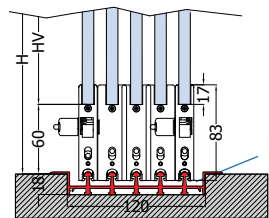

$$HV = H - 90$$

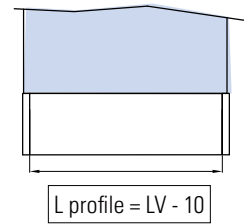
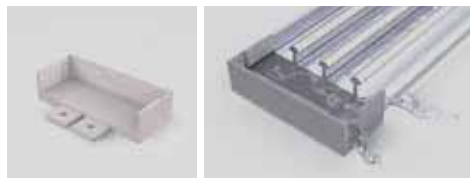
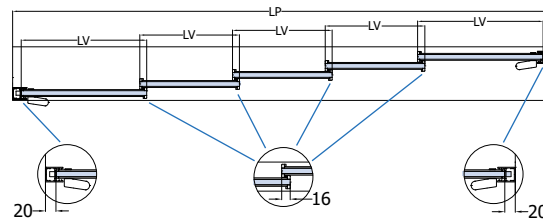

- Taglio guida a terra =
  - Bottom rail length =
  - Länge Bodenschiene =
- LP - 64
- 
- LG-535**

**LG-535 (OPTIONAL)**

- Sistema scarico acqua laterale per la guida inferiore 5 vie
- Side drainage system for 5-ways floor profile
- Seitliches Entwässerungssystem für 5-läufige Bodenschiene

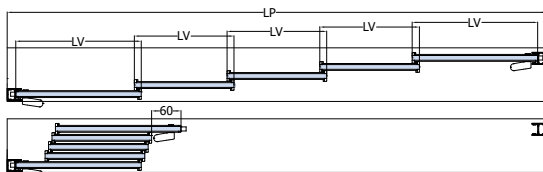

**FORMULE CALCOLO VETRI VEDI PAG 163**  
**CALCULATION GLASS SEE PAGE 163**  
**GLASBERECHNUNG SIEHE SEITE 163**

**LG-500**

- **Sistema di autobilanciamento**  
 Il nostro carrello a bilanciere autoregola la posizione delle 2 ruote in modo da assicurare lo scorrimento contemporaneo delle ruote sul binario
- **Auto balance mechanism**  
 Our seesaw roller system can actively self-adjust the position of the wheels to ensure the wheels are rolling on the rails at the same time
- **Auto balance**  
 Zwei Räder mit Kugellager, montiert auf einer Wippe, die das gleichzeitige Aufliegen auf der Schiene garantiert. Dadurch wird die Schiebewegung besonders fließend.

xme571e

**LP** Passaggio luce  
Clear opening width  
Lichte Durchgangsbreite

**LV** Larghezza vetro  
Glass width  
Glass Breite

**H** Altezza passaggio luce  
Clear opening height  
Lichte Durchgangshöhe

**HV** Altezza vetro  
Glass height  
Glass Höhe

**AN** Alluminio anodizzato  
Aluminium anodized  
Aluminium Silberfarbig

**BI** Bianco Ral 9010  
White Ral 9010  
Weiss Ral 9010

# LOGGIAGLAS LG-500 SET 2

## CALCOLO VETRI / GLASS CALCULATION / GLASBERECHNUNG

**C1\*** = **con** 1 catenacciolo / **with** 1 locking bolt / **mit** 1 Feststellriegel / **C2\*** = **con** 2 catenaccioli / **with** 2 locking bolts / **mit** 2 Feststellriegel

### LG-500-C1/C2\* / LG-500-12-C1/C2\*

- Formula calcolo larghezza ante **con** catenaccioli o serrature e **con** montanti laterali LG-508
- Glass calculation **with** locking bolts or locks and **with** "U" side profile LG-508
- Glasberechnung **mit** Feststellriegel oder Schloss und **mit** "U"-seitlichem Profil LG-508

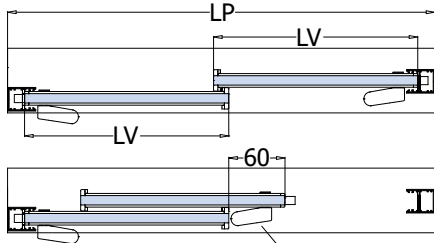

#### SET 2

$$LV = LP / 2$$

$$LV \text{ Anta Laterale } A = LV - 11$$

#### SET 2 + SET 2

$$LV = LP / 4$$

$$LV \text{ Anta Laterale } A = LV$$

### LG-500 / LG-500-12

- Formula calcolo larghezza ante **senza** catenaccioli o serrature e **senza** montanti laterali LG-508
- Glass calculation **without** locking bolts or locks and **without** "U" side profile LG-508
- Glasberechnung **ohne** Feststellriegel bzw. Schloss und **ohne** "U"-seitliches Profil LG-508

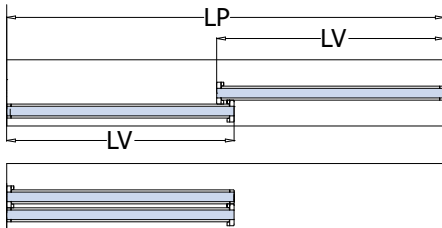

#### SET 2

$$LV = LP / 2$$

$$LV \text{ Anta Laterale } A = LV + 10$$

#### SET 2 + SET 2

$$LV = LP / 4$$

$$LV \text{ Anta Laterale } A = LV + 10$$

### LG-500 / LG-500-12

- Formula calcolo larghezza ante **senza** catenaccioli e **senza** montanti laterali LG-508, **con** serratura V-784
- Glass calculation **without** locking bolts and **without** "U" side profile LG-508, **with** locks V-784
- Glasberechnung **ohne** Feststellriegel und **ohne** "U"-seitliches Profil LG-508, **mit** Schloss V-784

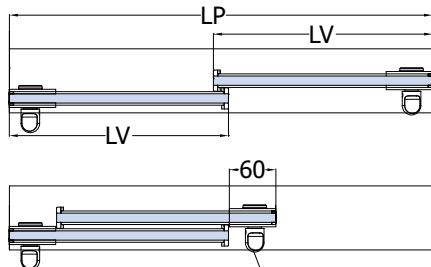

#### SET 2

$$LV = LP / 2$$

$$LV \text{ Anta Laterale } A = LV + 9$$

#### SET 2 + SET 2

$$LV = LP / 4$$

$$LV \text{ Anta Laterale } A = LV + 9$$

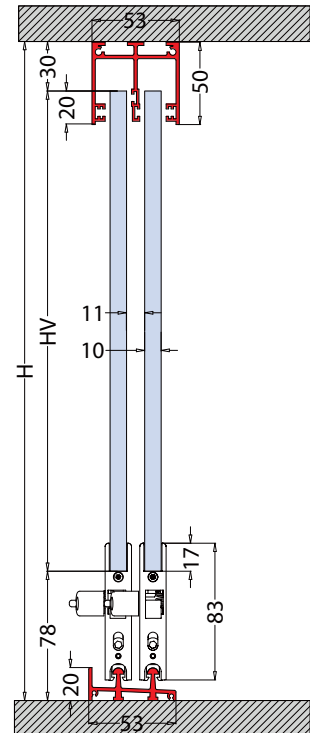

$$HV = H - 108$$

### LG-510 / LG-510-12 / LG-560

- Set con guida inferiore incassata
- Set with recessed floor profile
- Set mit versenkter Bodenschiene

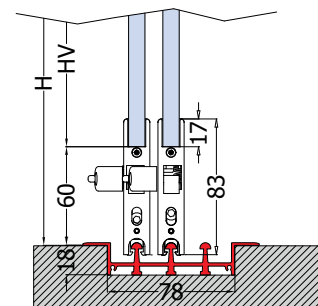

$$HV = H - 90$$

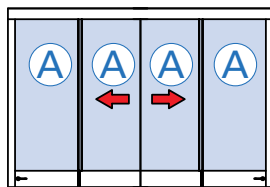
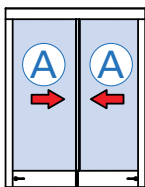

**LP**  
Passaggio luce  
Clear opening width  
Lichte Durchgangsbreite

**LV**  
Larghezza vetro  
Glass width  
Glas Breite

**H**  
Altezza passaggio luce  
Clear opening height  
Lichte Durchgangshöhe

**HV**  
Altezza vetro  
Glass height  
Glas Höhe

# LOGGIAGLAS LG-500 SET 3

## CALCOLO VETRI / GLASS CALCULATION / GLASBERECHNUNG

**C1\*** = **con** 1 catenacciolo / **with** 1 locking bolt / **mit** 1 Feststellriegel / **C2\*** = **con** 2 catenaccioli / **with** 2 locking bolts / **mit** 2 Feststellriegel

### LG-500-C1/C2\* / LG-500-12-C1/C2\*

- Formula calcolo larghezza ante **con** catenaccioli o serrature e **con** montanti laterali LG-508
- Glass calculation **with** locking bolts or locks and **with** "U" side profile LG-508
- Glasberechnung **mit** Feststellriegel oder Schloss und **mit** "U"-seitlichem Profil LG-508

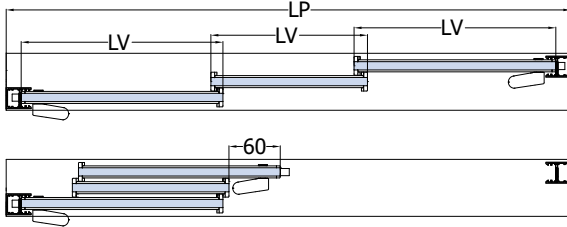

#### SET 3

LV = LP / 3  
 LV Anta Laterale A = LV + 18  
 LV Anta Centrale B = LV - 42

#### SET 3 + SET 3

LV = LP / 6  
 LV Anta Laterale A = LV + 25  
 LV Anta Centrale B = LV - 35

### LG-500 / LG-500-12

- Formula calcolo larghezza ante **senza** catenaccioli o serrature e **senza** montanti laterali LG-508
- Glass calculation **without** locking bolts or locks and **without** "U" side profile LG-508
- Glasberechnung **ohne** Feststellriegel bzw. Schloss und **ohne** "U"-seitliches Profil LG-508

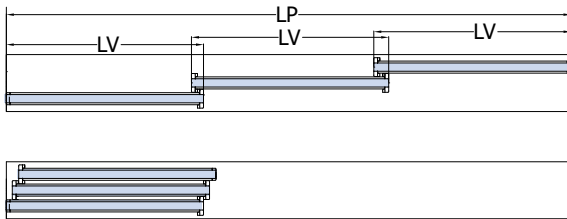

#### SET 3

LV = LP / 3  
 LV Anta Laterale A = LV + 12  
 LV Anta Centrale B = LV + 12

#### SET 3 + SET 3

LV = LP / 6  
 LV Anta Laterale A = LV + 12  
 LV Anta Centrale B = LV + 12

### LG-500 / LG-500-12

- Formula calcolo larghezza ante **senza** catenaccioli e **senza** montanti laterali LG-508, **con** serratura V-784
- Glass calculation **without** locking bolts and **without** "U" side profile LG-508, **with** locks V-784
- Glasberechnung **ohne** Feststellriegel und **ohne** "U"-seitliches Profil LG-508, **mit** Schloss V-784

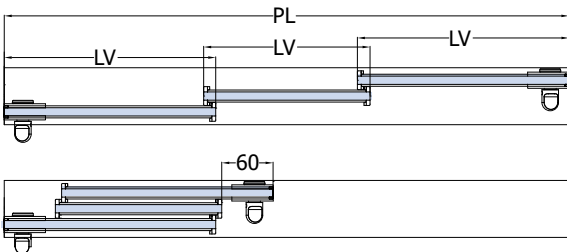

#### SET 3

LV = LP / 3  
 LV Anta Laterale A = LV + 31  
 LV Anta Centrale B = LV - 29

#### SET 3 + SET 3

LV = LP / 6  
 LV Anta Laterale A = LV + 31  
 LV Anta Centrale B = LV - 29

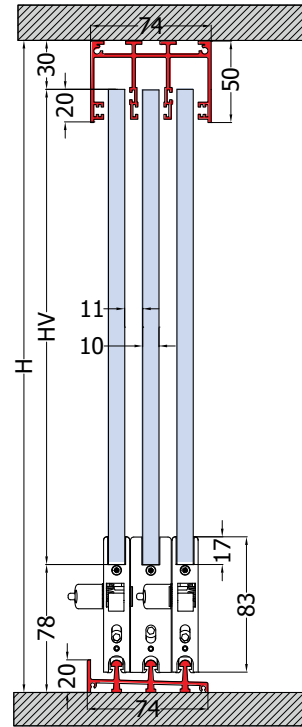

$$HV = H - 108$$

### LG-510 / LG-510-12 / LG-560

- Set con guida inferiore incassata
- Set with recessed floor profile
- Set mit versenkter Bodenschiene

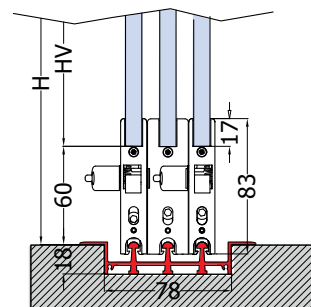

$$HV = H - 90$$

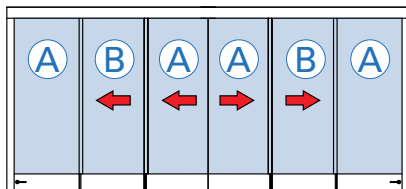
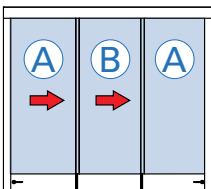

**LP**  
 Passaggio luce  
 Clear opening width  
 Lichte Durchgangsbreite

**LV**  
 Larghezza vetro  
 Clear opening width  
 Glas Breite

**H**  
 Altezza passaggio luce  
 Clear opening height  
 Lichte Durchgangshöhe

**HV**  
 Altezza vetro  
 Glass height  
 Glas Höhe

# LOGGIAGLAS LG-500 SET 4

## CALCOLO VETRI / GLASS CALCULATION / GLASBERECHNUNG

C1\* = con 1 catenacciolo / with 1 locking bolt / mit 1 Feststellriegel / C2\* = con 2 catenaccioli / with 2 locking bolts / mit 2 Feststellriegel

### LG-500-C1/C2\* / LG-500-12-C1/C2\*

- Formula calcolo larghezza ante **con** catenaccioli o serrature e **con** montanti laterali LG-508
- Glass calculation **with** locking bolts or locks and **with** "U" side profile LG-508
- Glasberechnung **mit** Feststellriegel oder Schloss und **mit** "U"-seitlichem Profil LG-508

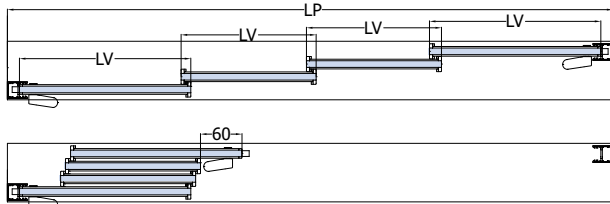

#### SET 4

$$LV = LP / 4$$

$$LV \text{ Anta Laterale A} = LV + 33$$

$$LV \text{ Anta Centrale B} = LV - 27$$

#### SET 4 + SET 4

$$LV = LP / 8$$

$$LV \text{ Anta Laterale A} = LV + 38$$

$$LV \text{ Anta Centrale B} = LV - 22$$

### LG-500 / LG-500-12

- Formula calcolo larghezza ante **senza** catenaccioli o serrature e **senza** montanti laterali LG-508
- Glass calculation **without** locking bolts or locks and **without** "U" side profile LG-508
- Glasberechnung **ohne** Feststellriegel bzw. Schloss und **ohne** "U"-seitliches Profil LG-508

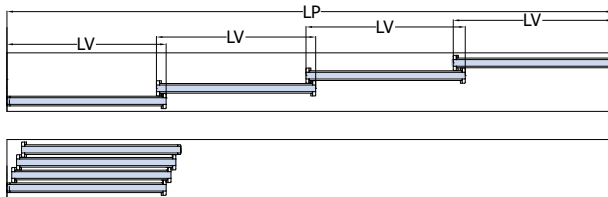

#### SET 4

$$LV = LP / 4$$

$$LV \text{ Anta Laterale A} = LV + 13$$

$$LV \text{ Anta Centrale B} = LV + 13$$

#### SET 4 + SET 4

$$LV = LP / 8$$

$$LV \text{ Anta Laterale A} = LV + 13$$

$$LV \text{ Anta Centrale B} = LV + 13$$

### LG-500 / LG-500-12

- Formula calcolo larghezza ante **senza** catenaccioli e **senza** montanti laterali LG-508, **con** serratura V-784
- Glass calculation **without** locking bolts and **without** "U" side profile LG-508, **with** locks V-784
- Glasberechnung **ohne** Feststellriegel und **ohne** "U"-seitliches Profil LG-508, **mit** Schloss V-784

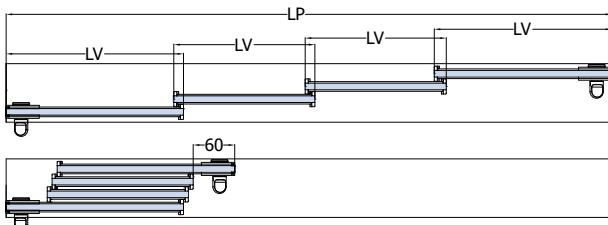

#### SET 4

$$LV = LP / 4$$

$$LV \text{ Anta Laterale A} = LV + 43$$

$$LV \text{ Anta Centrale B} = LV - 17$$

#### SET 4 + SET 4

$$LV = LP / 8$$

$$LV \text{ Anta Laterale A} = LV + 43$$

$$LV \text{ Anta Centrale B} = LV - 17$$

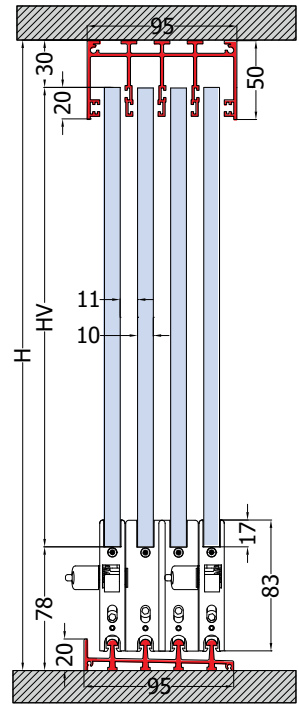

$$HV = H - 108$$

### LG-510 / LG-510-12 / LG-560

- Set con guida inferiore incassata
- Set with recessed floor profile
- Set mit versenkter Bodenschiene

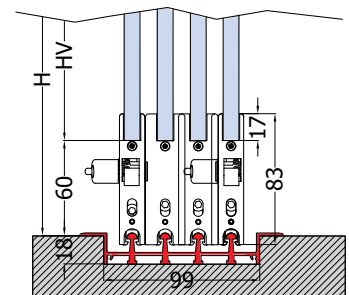

$$HV = H - 90$$

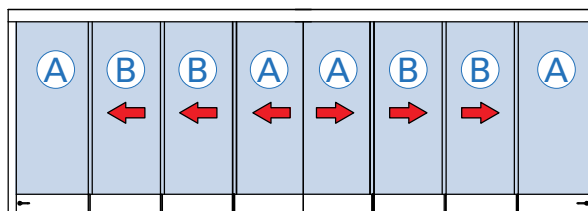
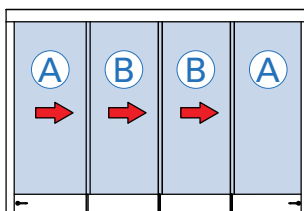

**LP**  
Passaggio luce  
Clear opening width  
Lichte Durchgangsbreite

**LV**  
Larghezza vetro  
Glass width  
Glas Breite

**H**  
Altezza passaggio luce  
Clear opening height  
Lichte Durchgangshöhe

**HV**  
Altezza vetro  
Glass height  
Glas Höhe

# LOGGIAGLAS LG-500 SET 5

## CALCOLO VETRI / GLASS CALCULATION / GLASBERECHNUNG

**C1\*** = con 1 catenacciolo / with 1 locking bolt / mit 1 Feststellriegel / **C2\*** = con 2 catenaccioli / with 2 locking bolts / mit 2 Feststellriegel

### LG-500-C1/C2\* / LG-500-12-C1/C2\*

- Formula calcolo larghezza ante **con** catenaccioli o serrature e **con** montanti laterali LG-508
- Glass calculation **with** locking bolts or locks and **with** "U" side profile LG-508
- Glasberechnung **mit** Feststellriegel oder Schloss und **mit** "U"-seitlichem Profil LG-508

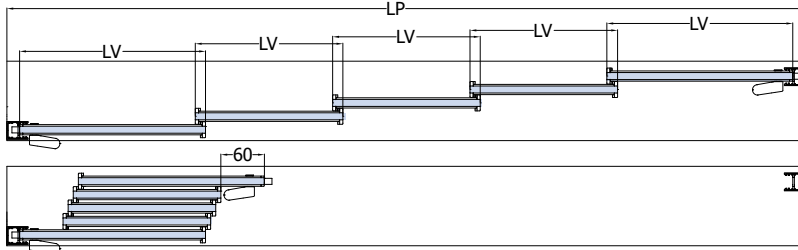

#### SET 5

LV = LP / 5  
 LV Anta Laterale A = LV + 41  
 LV Anta Centrale B = LV - 19

#### SET 5 + SET 5

LV = LP / 10  
 LV Anta Laterale A = LV + 45  
 LV Anta Centrale B = LV - 15

### LG-500 / LG-500-12

- Formula calcolo larghezza ante **senza** catenaccioli o serrature e **senza** montanti laterali LG-508
- Glass calculation **without** locking bolts or locks and **without** "U" side profile LG-508
- Glasberechnung **ohne** Feststellriegel bzw. Schloss und **ohne** "U"-seitliches Profil LG-508

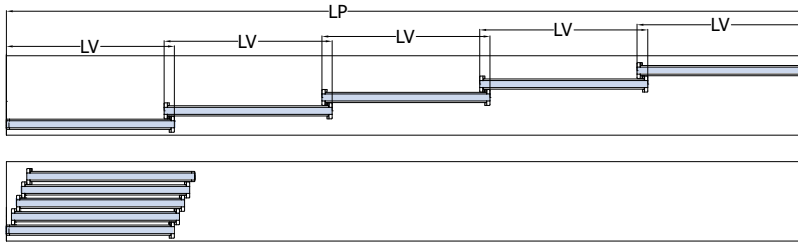

#### SET 5

LV = LP / 5  
 LV Anta Laterale A = LV + 13  
 LV Anta Centrale B = LV + 13

#### SET 5 + SET 5

LV = LP / 10  
 LV Anta Laterale A = LV + 13  
 LV Anta Centrale B = LV + 13

### LG-500 / LG-500-12

- Formula calcolo larghezza ante **senza** catenaccioli e **senza** montanti laterali LG-508, **con** serratura V-784
- Glass calculation **without** locking bolts and **without** "U" side profile LG-508, **with** locks V-784
- Glasberechnung **ohne** Feststellriegel und **ohne** "U"-seitliches Profil LG-508, **mit** Schloss V-784

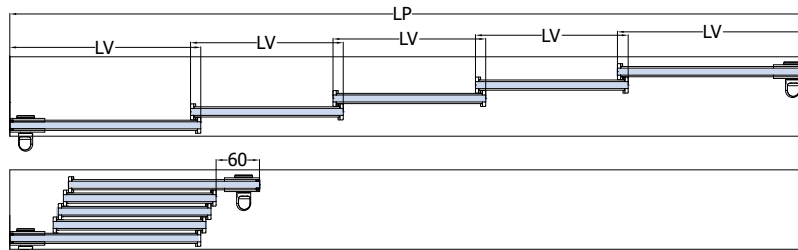

#### SET 5

LV = LP / 5  
 LV Anta Laterale A = LV + 49  
 LV Anta Centrale B = LV - 11

#### SET 5 + SET 5

LV = LP / 10  
 LV Anta Laterale A = LV + 49  
 LV Anta Centrale B = LV - 11

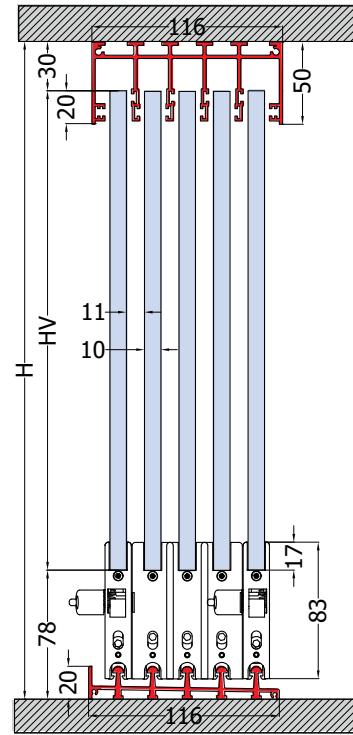

HV = H - 108

### LG-510 / LG-510-12 / LG-560

- Set con guida inferiore incassata
- Set with recessed floor profile
- Set mit versenkter Bodenschiene

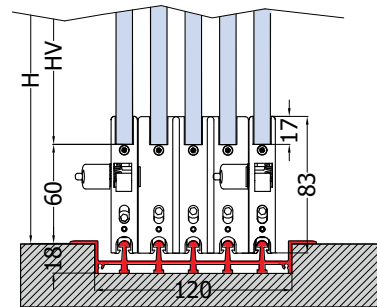

HV = H - 90

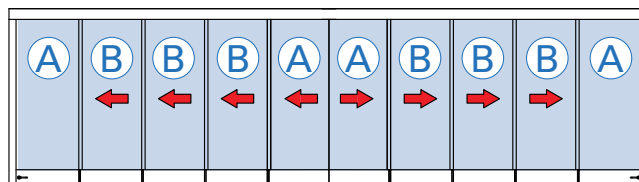
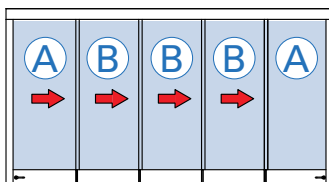

**LP**  
 Passaggio luce  
 Clear opening width  
 Lichte Durchgangsbreite

**LV**  
 Larghezza vetro  
 Glass width  
 Glas Breite

**H**  
 Altezza passaggio luce  
 Clear opening height  
 Lichte Durchgangshöhe

**HV**  
 Altezza vetro  
 Glass height  
 Glas Höhe

# NUOVO LG-400 60 KG

Il nuovo carrello progettato per ante fino a 60 Kg.  
Presenta un profilo alto solamente 64 mm per vetri da 8/10 mm.

NEW

New trolley designed for panels up to 60 Kg.  
Glass profile height only 64 mm, for glass 8/10 mm.

Neuer Laufwagen für Türen bis 60 Kg.  
Glasprofilhöhe nur 64 mm für 8/10 mm Glas.

# PLUS

PATENT  
PENDING



**6** Antisollevamento delle ante integrato nel carrello per una sicurezza assoluta ed una semplicità di rimozione, nel caso di manutenzione, grazie al nuovo brevetto Metalglas.

Anti-lifting doors integrated into the trolley for absolute safety and easy removal, in the event of maintenance, thanks to the new Metalglas patent.

Im Wagen ist ein System integriert, das ein Anheben der Türen verhindert. Es sorgt für absolute Sicherheit und garantiert ein einfaches Entfernen für die Wartung. Dies ist dem neuen Patent von Metalglas zu verdanken.

## 1 Una ruota per carrello per ante fino a 60 Kg.

One wheel for trolley for panels up to 60 Kg of glass.  
 Ein Rad pro Wagen für Glas einem Gewicht von bis zu 60 kg.

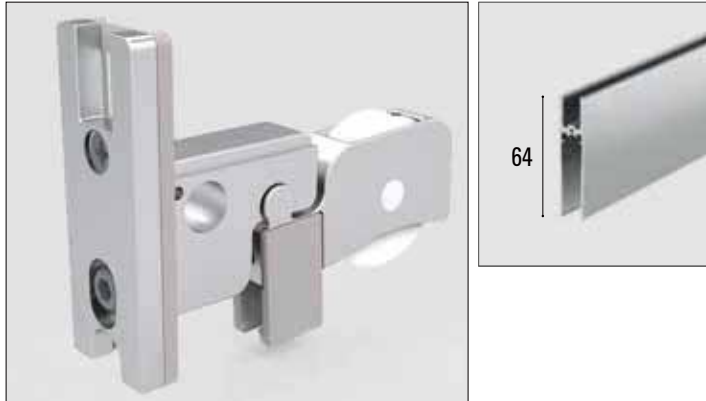

LG-400			LG-400-8		
60 Kg	10	900	60 Kg	8	900
		2600			2600

## 2 Facile regolazione in altezza delle ante.

The new trolley also facilitates height adjustment of the doors.

Der neue Wagen ermöglicht außerdem das leichte Einstellen der Höhe der Türen.



## 3 Basta tagliare il profilo a misura ed infilare i due carrelli ed il gioco è fatto. Nessuna lavorazione sui profili per questo sistema fantastico ed innovativo.

Just cut the profile to size and slide in the two carts, that's it! No further processing is required on the profiles for this fantastic and innovative system.

Dazu reicht es aus, das Profil nach Maß zuzuschneiden und die zwei Wägen einzufügen. Schon ist die Arbeit erledigt. Keine Arbeit an den Profilen dank dieses fantastischen und innovativen Systems.



## 4 Mai più destro o sinistro. Un unico accessorio per tutte le tipologie di apertura.

No longer left or right, a single accessory for all types of openings.

Nie mehr rechts oder links - ein einziges Werkzeug für alle Öffnungsrichtungen.



## 5 Un altro vantaggio estetico e tecnico è il catenacciolo integrato nel carrello. Semplicità e velocità di applicazione.

Another aesthetic and technical advantage is the locking latch integrated into the trolley. Simplicity and speed of application.

Ein weiterer ästhetischer und technischer Vorteil besteht im Schließbolzen, der in den Wagen integriert ist. Einfache und schnelle Anwendung.



## LOGGIAGLAS LG-400 NEW

- Sistema scorrevole telescopico studiato per balconi, logge e verande.
- Telescopic sliding system for balconies, loggias and terraces.
- Teleskop Schiebetürsystem für Balkon und Loggiaverglasungen.







- LOGGIAGLAS LG-400 SET 2 ▶ 168**
- LOGGIAGLAS LG-400 SET 3 ▶ 170**
- LOGGIAGLAS LG-400 SET 4 ▶ 172**
- LOGGIAGLAS LG-400 SET 5 ▶ 174**

- Sistema 2 ante telescopiche
- System for 2 telescopic doors
- System mit 2 Teleskoptüren
- Sistema 3 ante telescopiche
- System for 3 telescopic doors
- System mit 3 Teleskoptüren
- Sistema 4 ante telescopiche
- System for 4 telescopic doors
- System mit 4 Teleskoptüren
- Sistema 5 ante telescopiche
- System for 5 telescopic doors
- System mit 5 Teleskoptüren

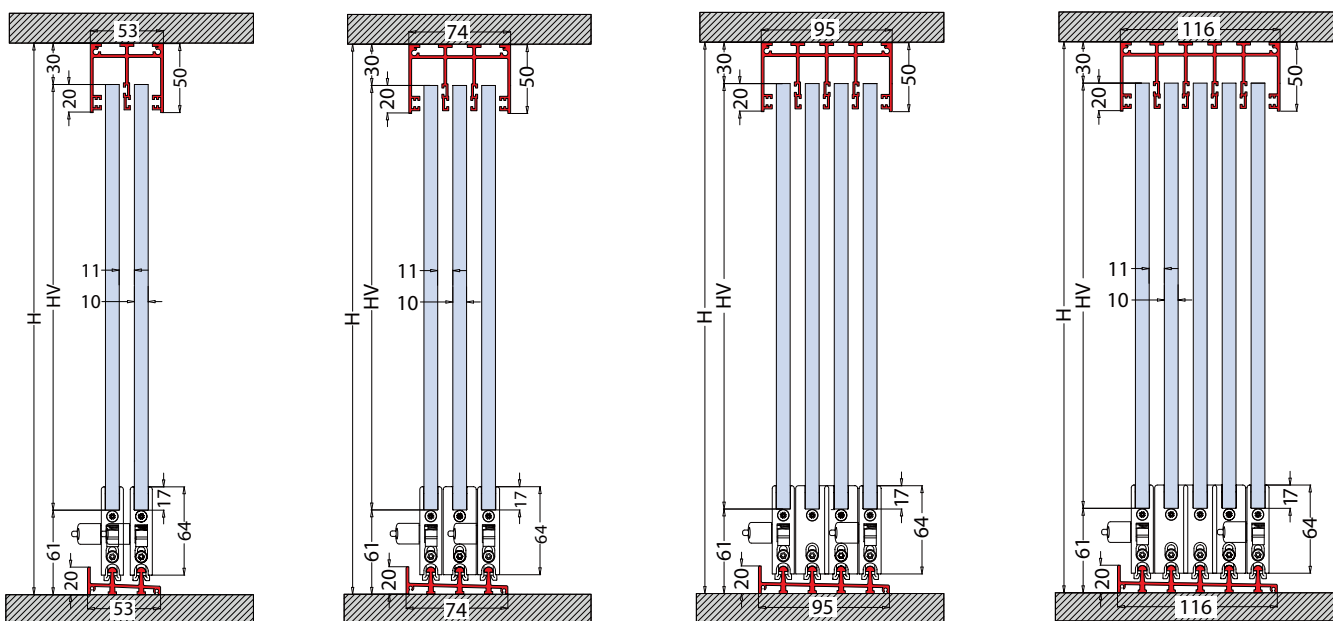

- Possibilità di installare guida a terra incassata nel pavimento
- Ability to install a similar rail embedded in the floor
- Möglichkeit eine Führungsschiene in den Boden einzubauen

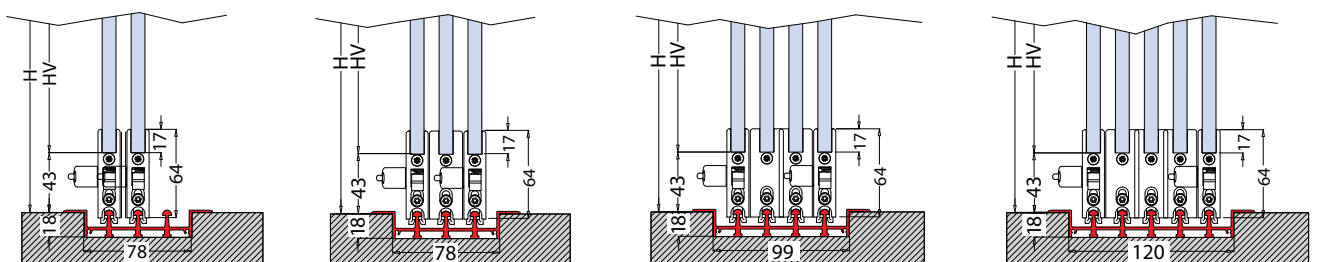

set 2    set 2 + set 2

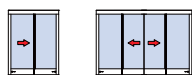

set 3    set 3 + set 3

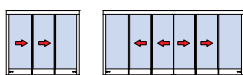

set 4    set 4 + set 4

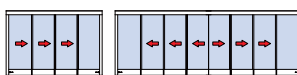

set 5

set 5 + set 5



## LOGGIAGLAS LG-400 SET 2

€▶ C.330

€▶ C.331

SCORREVOLE TELESCOPICO / TELESCOPIC SLIDING SYSTEM / TELESKOP SCHIEBETÜRSYSTEM

- SISTEMA CON GUIDA A TERRA: Sistema scorrevole telescopico studiato per balconi, logge e verande, ideale per proteggersi da vento e intemperie.
- SYSTEMS WITH BOTTOM GUIDE: Telescopic sliding system for balconies, loggias and terraces, ideal for wind and weather protection.
- SYSTEM MIT BODENFÜHRUNG: Teleskop Schiebetürsystem für Balkon und Loggiaverglasungen, ideal für Wind-und Wetterschutz.



### COMPONENTI / COMPONENTS / EINZELTEILE



LG-528



LG-529



LG-503



LG-405



LG-508



LG-409



LG-410



LG-511

LG-400-8	LG-400	
 60 Kg	 8	 900 2600
 60 Kg	 10	 900 2500
2 ruote per anta / 2 wheels each panel / 2 Rollen je Flügel		

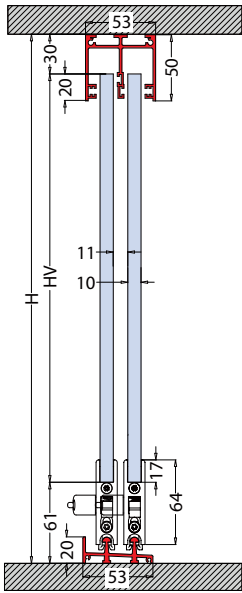
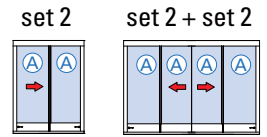

$$HV = H - 91$$

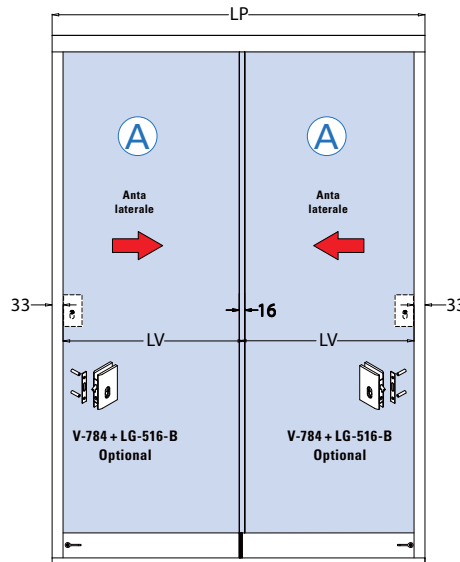

### LG-410

- Set con guida inferiore incassata
- Set with recessed floor profile
- Set mit versenkter Bodenschiene

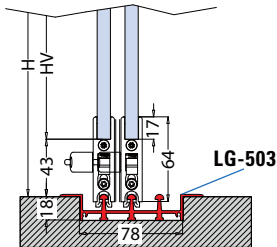

$$HV = H - 73$$

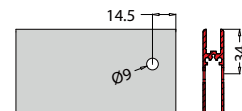
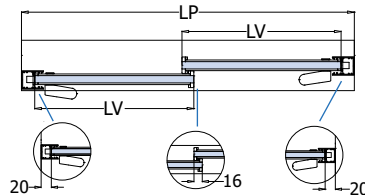

- Lavorazione profilo anta per catenacciolo LG-511 / LG-512
- Preparation panel profile for Locking bolt LG-511 / LG-512
- Profilbearbeitung für Feststellriegel LG-511 / LG-512

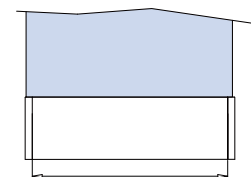

$$L \text{ profile} = LV - 10$$

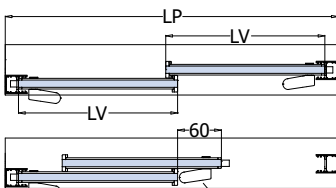

**FORMULE CALCOLO VETRI VEDI PAG 176**  
**CALCULATION GLASS SEE PAGE 176**  
**GLASBERECHNUNG SIEHE SEITE 176**

<b>LP</b> Passaggio luce Clear opening width Lichte Durchgangsbreite	<b>LV</b> Larghezza vetro Glass width Glas Breite	<b>H</b> Altezza passaggio luce Clear opening height Lichte Durchgangshöhe	<b>HV</b> Altezza vetro Glass height Glas Höhe	<b>AN</b> Alluminio anodizzato Aluminium anodized Aluminium Silberfarbig	<b>BI</b> Bianco Ral 9010 White Ral 9010 Weiss Ral 9010
---	--	---	---	---	--

xme622b

# LOGGIAGLAS LG-400 SET 3

€ ▶ C.330

€ ▶ C.331

SCORREVOLE TELESCOPICO / TELESCOPIC SLIDING SYSTEM / TELESKOP SCHIEBETÜRSYSTEM

- SISTEMA CON GUIDA A TERRA: Sistema scorrevole telescopico studiato per balconi, logge e verande, ideale per proteggersi da vento e intemperie.
- SYSTEMS WITH BOTTOM GUIDE: Telescopic sliding system for balconies, loggias and terraces, ideal for wind and weather protection.
- SYSTEM MIT BODENFÜHRUNG: Teleskop Schiebetürsystem für Balkon und Loggiaverglasungen, ideal für Wind-und Wetterschutz.



## COMPONENTI / COMPONENTS / EINZELTEILE



LG-501



LG-502

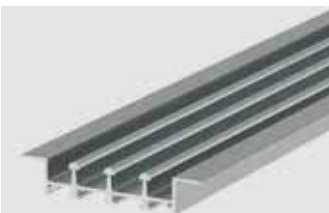

LG-503



LG-405

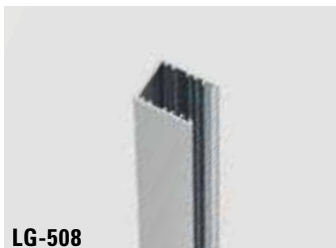

LG-508



LG-409



LG-410



LG-511

LG-400-8				LG-400			
			2600				2500
60 Kg	8	900		60 Kg	10	900	

2 ruote per anta / 2 wheels each panel / 2 Rollen je Flügel

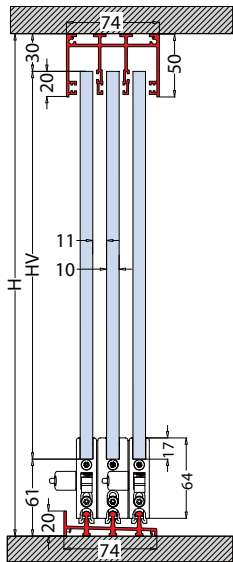
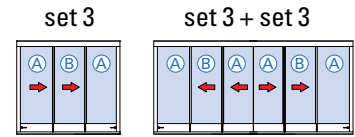

$$HV = H - 91$$

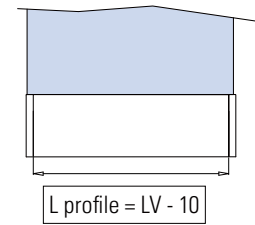
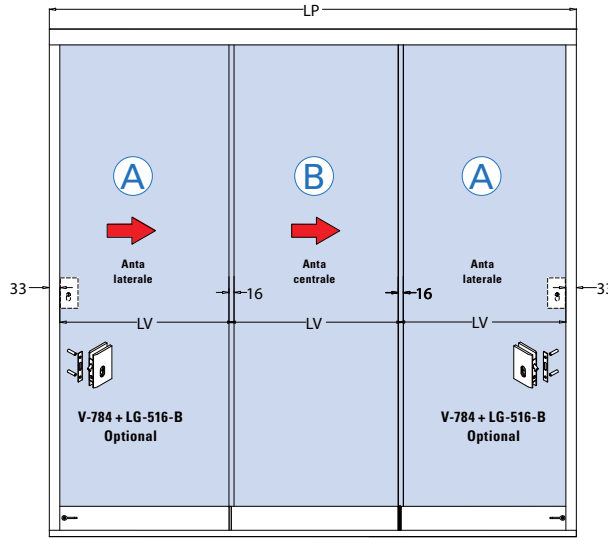
**LG-410**

- Set con guida inferiore incassata
- Set with recessed floor profile
- Set mit versenkter Bodenschiene

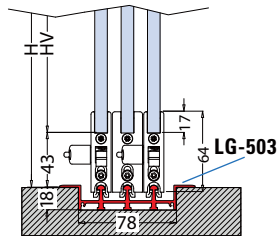

$$HV = H - 73$$

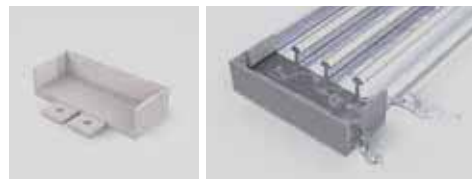
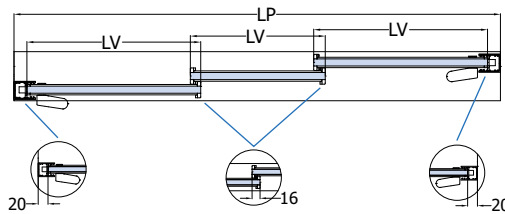
**LG-533 (OPTIONAL)**

- Sistema scarico acqua laterale per la guida inferiore 3 vie
- Side drainage system for 3-ways floor profile
- Seitliches Entwässerungssystem für 3-läufige Bodenschiene

- Taglio guida a terra =
- Bottom rail length =
- Länge Bodenschiene =

LP - 64

**LG-533**

- Lavorazione profilo anta per catenacciolo LG-511 / LG-512
- Preparation panel profile for Locking bolt LG-511 / LG-512
- Profilbearbeitung für Feststellriegel LG-511 / LG-512

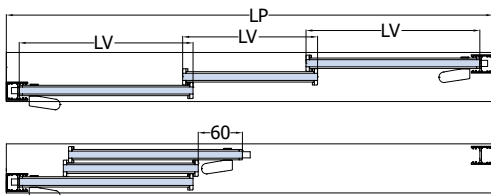

**FORMULE CALCOLO VETRI VEDI PAG 177**  
**CALCULATION GLASS SEE PAGE 177**  
**GLASBERECHNUNG SIEHE SEITE 177**

**LP**  
 Passaggio luce  
 Clear opening width  
 Lichte Durchgangsbreite

**LV**  
 Larghezza vetro  
 Glass width  
 Glas Breite

**H**  
 Altezza passaggio luce  
 Clear opening height  
 Lichte Durchgangshöhe

**HV**  
 Altezza vetro  
 Glass height  
 Glas Höhe

**AN**  
 Alluminio anodizzato  
 Aluminium anodized  
 Aluminium Silberfarbig

**BI**  
 Bianco Ral 9010  
 White Ral 9010  
 Weiss Ral 9010

xme622c

## LOGGIAGLAS LG-400 SET 4

€ ▶ C.330

€ ▶ C.331

SCORREVOLE TELESCOPICO / TELESCOPIC SLIDING SYSTEM / TELESKOP SCHIEBETÜRSYSTEM

- SISTEMA CON GUIDA A TERRA: Sistema scorrevole telescopico studiato per balconi, logge e verande, ideale per proteggersi da vento e intemperie.
- SYSTEMS WITH BOTTOM GUIDE: Telescopic sliding system for balconies, loggias and terraces, ideal for wind and weather protection.
- SYSTEM MIT BODENFÜHRUNG: Teleskop Schiebetürsystem für Balkon und Loggiaverglasungen, ideal für Wind-und Wetterschutz.



### COMPONENTI / COMPONENTS / EINZELTEILE



LG-504

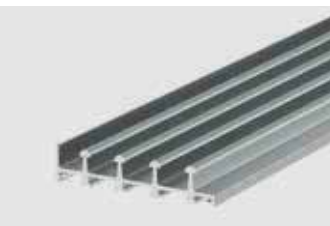

LG-506

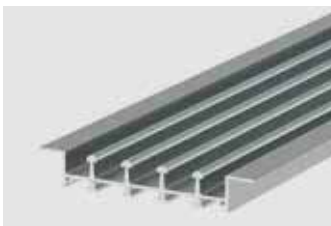

LG-507



LG-405

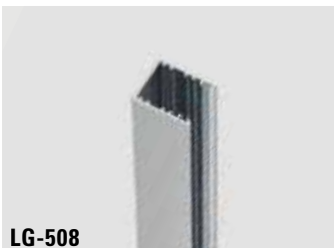

LG-508



LG-409



LG-410



LG-511

LG-400-8				LG-400			
			2600				2500
60 Kg	8	900		60 Kg	10	900	

2 ruote per anta / 2 wheels each panel / 2 Rollen je Flügel

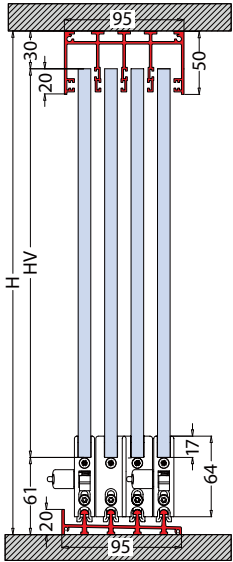
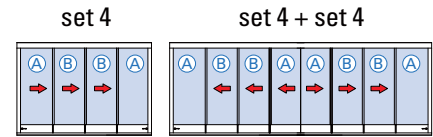

$$HV = H - 91$$

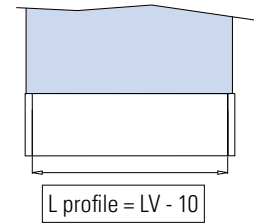
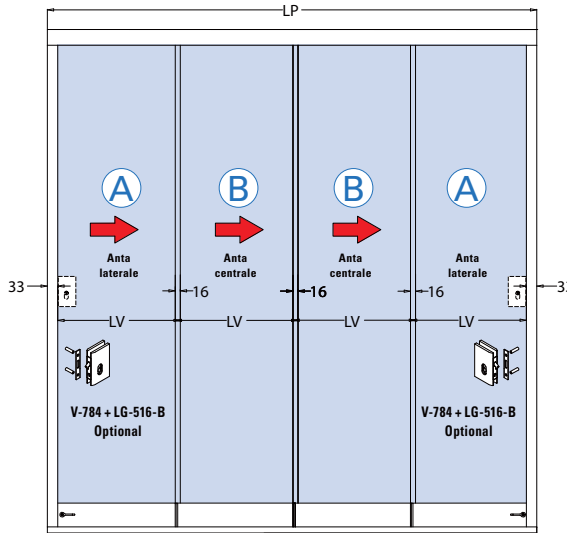

#### LG-410

- Set con guida inferiore incassata
- Set with recessed floor profile
- Set mit versenkter Bodenschiene

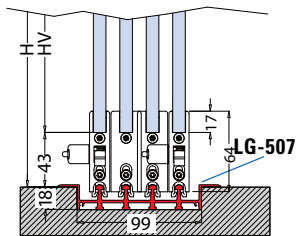

$$HV = H - 73$$

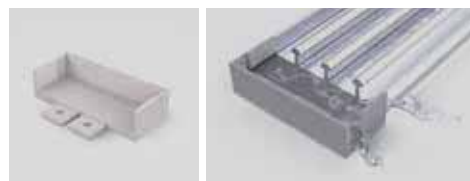
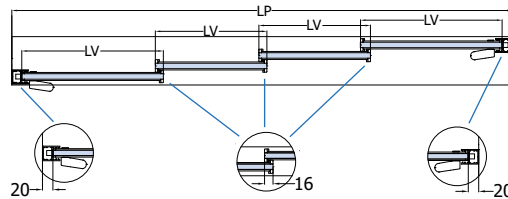

#### LG-534 (OPTIONAL)

- Sistema scarico acqua laterale per la guida inferiore 4 vie
- Side drainage system for 4-ways floor profile
- Seitliches Entwässerungssystem für 4-läufige Bodenschiene

- Taglio guida a terra =
- Bottom rail length =
- Länge Bodenschiene =

LP - 64

**LG-534**

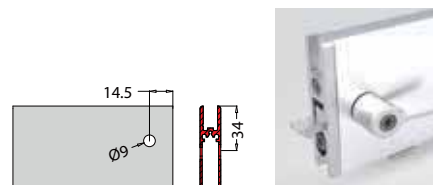

- Lavorazione profilo anta per catenacciolo LG-511 / LG-512
- Preparation panel profile for Locking bolt LG-511 / LG-512
- Profilbearbeitung für Feststellriegel LG-511 / LG-512

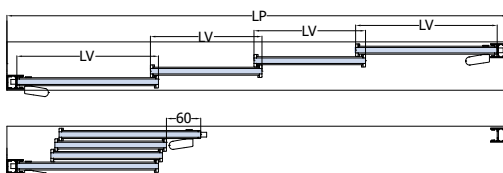

**FORMULE CALCOLO VETRI VEDI PAG 178**  
**CALCULATION GLASS SEE PAGE 178**  
**GLASBERECHNUNG SIEHE SEITE 178**

**LP**  
Passaggio luce  
Clear opening width  
Lichte Durchgangsbreite

**LV**  
Larghezza vetro  
Glass width  
Glass Breite

**H**  
Altezza passaggio luce  
Clear opening height  
Lichte Durchgangshöhe

**HV**  
Altezza vetro  
Glass height  
Glass Höhe

**AN**  
Alluminio anodizzato  
Aluminium anodized  
Aluminium Silberfarbig

**BI**  
Bianco Ral 9010  
White Ral 9010  
Weiss Ral 9010

xme622d

# LOGGIAGLAS LG-400 SET 5

€▶ C.330

€▶ C.331

SCORREVOLE TELESCOPICO / TELESCOPIC SLIDING SYSTEM / TELESKOP SCHIEBETÜRSYSTEM

- SISTEMA CON GUIDA A TERRA: Sistema scorrevole telescopico studiato per balconi, logge e verande, ideale per proteggersi da vento e intemperie.
- SYSTEMS WITH BOTTOM GUIDE: Telescopic sliding system for balconies, loggias and terraces, ideal for wind and weather protection.
- SYSTEM MIT BODENFÜHRUNG: Teleskop Schiebetürsystem für Balkon und Loggiaverglasungen, ideal für Wind-und Wetterschutz.



## COMPONENTI / COMPONENTS / EINZELTEILE



LG-513



LG-514



LG-515



LG-405



LG-508



LG-409



LG-410



LG-511



LG-400-8				LG-400			
			2600				2500
60 Kg	8	900		60 Kg	10	900	

2 ruote per anta / 2 wheels each panel / 2 Rollen je Flügel

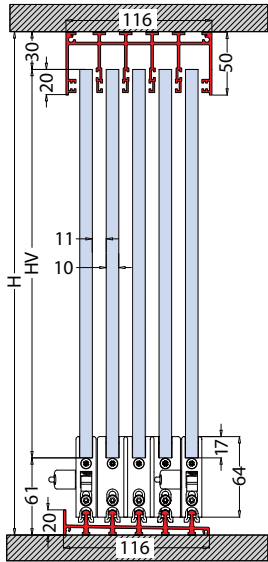
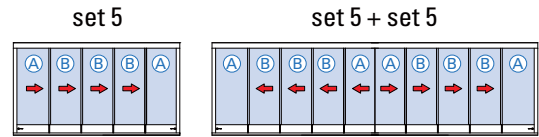

$$HV = H - 91$$

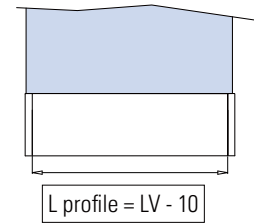
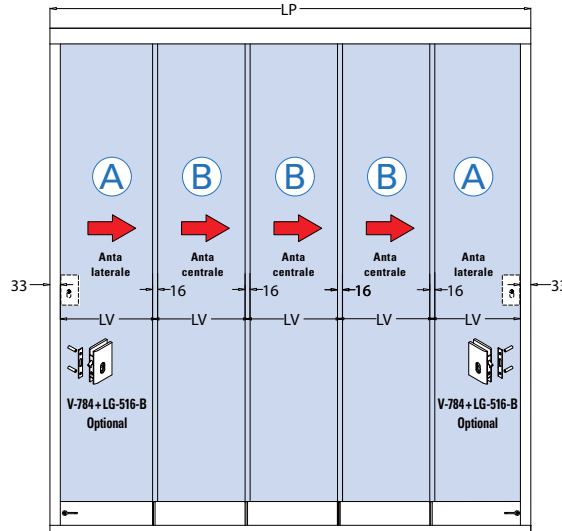
**LG-410**

- Set con guida inferiore incassata
- Set with recessed floor profile
- Set mit versenkter Bodenschiene

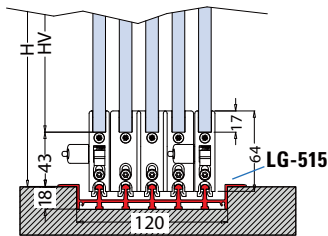

$$HV = H - 73$$

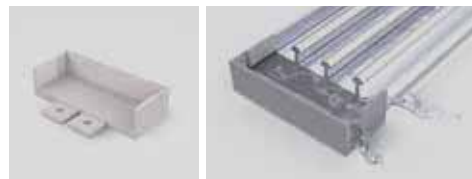
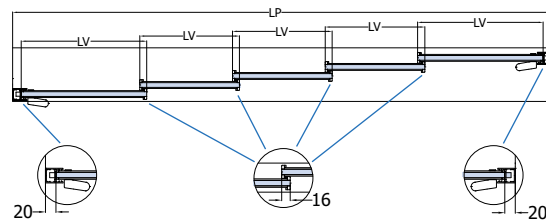
**LG-535 (OPTIONAL)**

- Sistema scarico acqua laterale per la guida inferiore 5 vie
- Side drainage system for 5-ways floor profile
- Seitliches Entwässerungssystem für 5-läufige Bodenschiene

- Taglio guida a terra =
- Bottom rail length =
- Länge Bodenschiene =

$$LP - 64$$

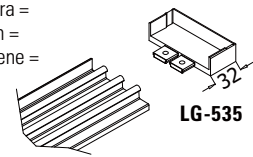
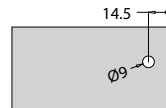
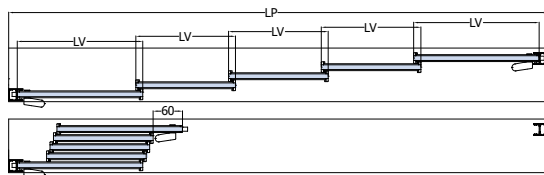
**LG-535**

- Lavorazione profilo anta per catenacciolo LG-511 / LG-512
- Preparation panel profile for Locking bolt LG-511 / LG-512
- Profilbearbeitung für Feststellriegel LG-511 / LG-512

**FORMULE CALCOLO VETRI VEDI PAG 179**  
**CALCULATION GLASS SEE PAGE 179**  
**GLASBERECHNUNG SIEHE SEITE 179**

**LP**  
 Passaggio luce  
 Clear opening width  
 Lichte Durchgangsbreite

**LV**  
 Larghezza vetro  
 Glass width  
 Glas Breite

**H**  
 Altezza passaggio luce  
 Clear opening height  
 Lichte Durchgangshöhe

**HV**  
 Altezza vetro  
 Glass height  
 Glas Höhe

**AN**  
 Alluminio anodizzato  
 Aluminium anodized  
 Aluminium Silberfarbig

**BI**  
 Bianco Ral 9010  
 White Ral 9010  
 Weiss Ral 9010

xme622e

# LOGGIAGLAS LG-400 SET 2

## CALCOLO VETRI / GLASS CALCULATION / GLASBERECHNUNG

C1\* = **con** 1 catenacciolo / **with** 1 locking bolt / **mit** 1 Feststellriegel / C2\* = **con** 2 catenaccioli / **with** 2 locking bolts / **mit** 2 Feststellriegel

### LG-400-C1/C2\*

- Formula calcolo larghezza ante **con** catenaccioli o serrature e **con** montanti laterali LG-508
- Glass calculation **with** locking bolts or locks and **with** "U" side profile LG-508
- Glasberechnung **mit** Feststellriegel oder Schloss und **mit** "U"-seitlichem Profil LG-508

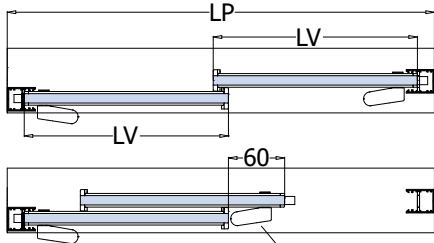

#### SET 2

$$LV = LP / 2$$

$$LV \text{ Anta Laterale } A = LV - 11$$

#### SET 2 + SET 2

$$LV = LP / 4$$

$$LV \text{ Anta Laterale } A = LV$$

### LG-400

- Formula calcolo larghezza ante **senza** catenaccioli o serrature e **senza** montanti laterali LG-508
- Glass calculation **without** locking bolts or locks and **without** "U" side profile LG-508
- Glasberechnung **ohne** Feststellriegel bzw. Schloss und **ohne** "U"-seitliches Profil LG-508

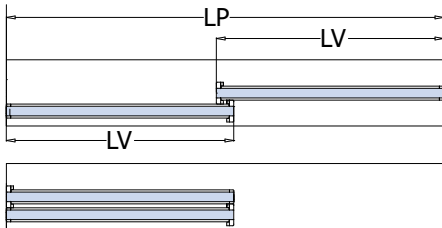

#### SET 2

$$LV = LP / 2$$

$$LV \text{ Anta Laterale } A = LV + 10$$

#### SET 2 + SET 2

$$LV = LP / 4$$

$$LV \text{ Anta Laterale } A = LV + 10$$

### LG-400

- Formula calcolo larghezza ante **senza** catenaccioli e **senza** montanti laterali LG-508, **con** serratura V-784
- Glass calculation **without** locking bolts and **without** "U" side profile LG-508, **with** locks V-784
- Glasberechnung **ohne** Feststellriegel und **ohne** "U"-seitliches Profil LG-508, **mit** Schloss V-784

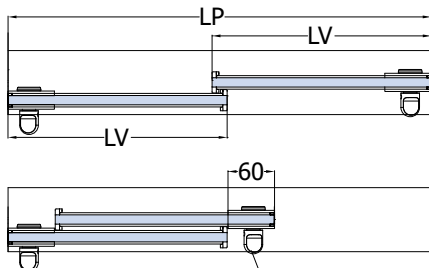

#### SET 2

$$LV = LP / 2$$

$$LV \text{ Anta Laterale } A = LV + 9$$

#### SET 2 + SET 2

$$LV = LP / 4$$

$$LV \text{ Anta Laterale } A = LV + 9$$

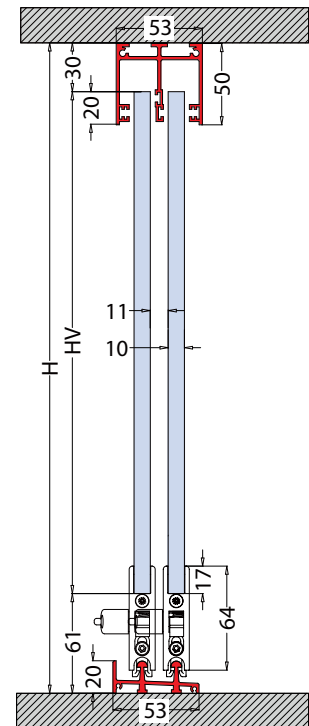

$$HV = H - 91$$

### LG-410

- Set con guida inferiore incassata
- Set with recessed floor profile
- Set mit versenkter Bodenschiene

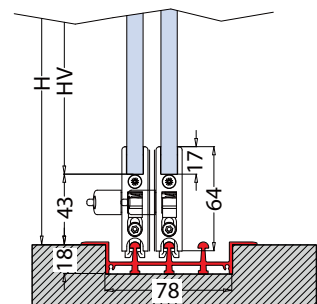

$$HV = H - 73$$

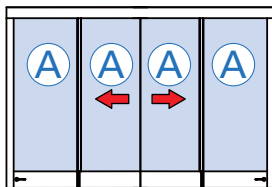
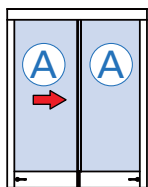

**LP**  
Passaggio luce  
Clear opening width  
Lichte Durchgangsbreite

**LV**  
Larghezza vetro  
Glass width  
Glas Breite

**H**  
Altezza passaggio luce  
Clear opening height  
Lichte Durchgangshöhe

**HV**  
Altezza vetro  
Glass height  
Glas Höhe

# LOGGIAGLAS LG-400 SET 3

## CALCOLO VETRI / GLASS CALCULATION / GLASBERECHNUNG

**C1\*** = con 1 catenacciolo / with 1 locking bolt / mit 1 Feststellriegel / **C2\*** = con 2 catenaccioli / with 2 locking bolts / mit 2 Feststellriegel

### LG-400-C1/C2\*

- Formula calcolo larghezza ante **con** catenaccioli o serrature e **con** montanti laterali LG-508
- Glass calculation **with** locking bolts or locks and **with** "U" side profile LG-508
- Glasberechnung **mit** Feststellriegel oder Schloss und **mit** "U"-seitlichem Profil LG-508

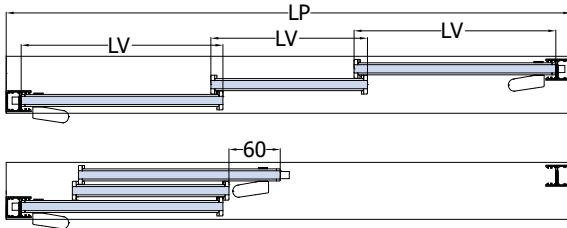

#### SET 3

$$LV = LP / 3$$

$$LV \text{ Anta Laterale A} = LV + 18$$

$$LV \text{ Anta Centrale B} = LV - 42$$

#### SET 3 + SET 3

$$LV = LP / 6$$

$$LV \text{ Anta Laterale A} = LV + 25$$

$$LV \text{ Anta Centrale B} = LV - 35$$

### LG-400

- Formula calcolo larghezza ante **senza** catenaccioli o serrature e **senza** montanti laterali LG-508
- Glass calculation **without** locking bolts or locks and **without** "U" side profile LG-508
- Glasberechnung **ohne** Feststellriegel bzw. Schloss und **ohne** "U"-seitliches Profil LG-508

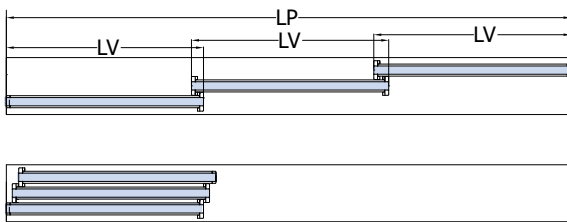

#### SET 3

$$LV = LP / 3$$

$$LV \text{ Anta Laterale A} = LV + 12$$

$$LV \text{ Anta Centrale B} = LV + 12$$

#### SET 3 + SET 3

$$LV = LP / 6$$

$$LV \text{ Anta Laterale A} = LV + 12$$

$$LV \text{ Anta Centrale B} = LV + 12$$

### LG-400

- Formula calcolo larghezza ante **senza** catenaccioli e **senza** montanti laterali LG-508, **con** serratura V-784
- Glass calculation **without** locking bolts and **without** "U" side profile LG-508, **with** locks V-784
- Glasberechnung **ohne** Feststellriegel und **ohne** "U"-seitliches Profil LG-508, **mit** Schloss V-784

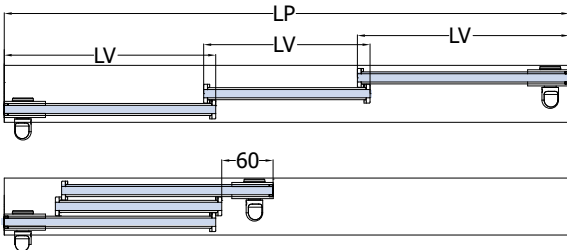

#### SET 3

$$LV = LP / 3$$

$$LV \text{ Anta Laterale A} = LV + 31$$

$$LV \text{ Anta Centrale B} = LV - 29$$

#### SET 3 + SET 3

$$LV = LP / 6$$

$$LV \text{ Anta Laterale A} = LV + 31$$

$$LV \text{ Anta Centrale B} = LV - 29$$

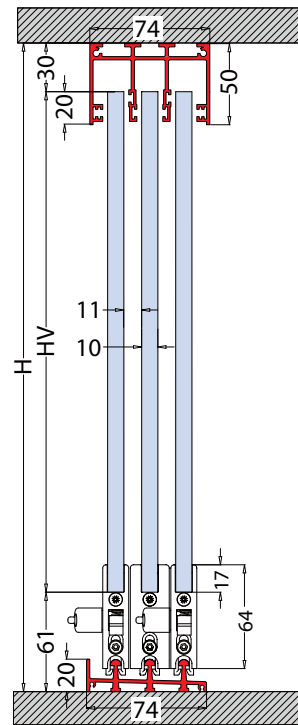

$$HV = H - 91$$

### LG-410

- Set con guida inferiore incassata
- Set with recessed floor profile
- Set mit versenkter Bodenschiene

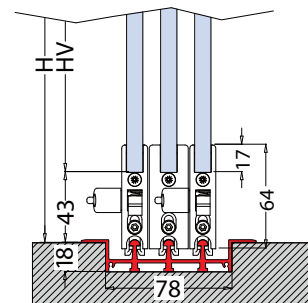

$$HV = H - 73$$

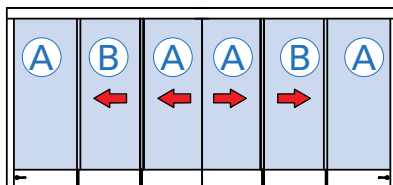
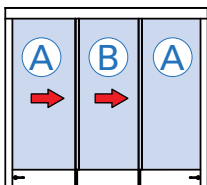

**LP**  
Passaggio luce  
Clear opening width  
Lichte Durchgangsbreite

**LV**  
Larghezza vetro  
Glass width  
Glass Breite

**H**  
Altezza passaggio luce  
Clear opening height  
Lichte Durchgangshöhe

**HV**  
Altezza vetro  
Glass height  
Glass Höhe

# LOGGIAGLAS LG-400 SET 4

## CALCOLO VETRI / GLASS CALCULATION / GLASBERECHNUNG

C1\* = con 1 catenacciolo / with 1 locking bolt / mit 1 Feststellriegel / C2\* = con 2 catenaccioli / with 2 locking bolts / mit 2 Feststellriegel

### LG-400-C1/C2\*

- Formula calcolo larghezza ante **con** catenaccioli o serrature e **con** montanti laterali LG-508
- Glass calculation **with** locking bolts or locks and **with** "U" side profile LG-508
- Glasberechnung **mit** Feststellriegel oder Schloss und **mit** "U"-seitlichem Profil LG-508

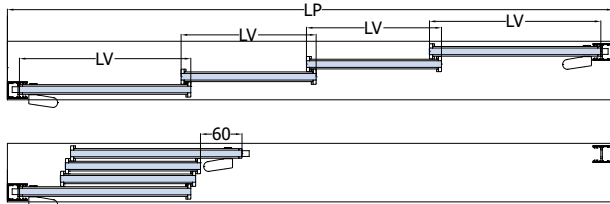

#### SET 4

$$LV = LP / 4$$

$$LV \text{ Anta Laterale A} = LV + 33$$

$$LV \text{ Anta Centrale B} = LV - 27$$

#### SET 4 + SET 4

$$LV = LP / 8$$

$$LV \text{ Anta Laterale A} = LV + 38$$

$$LV \text{ Anta Centrale B} = LV - 22$$

### LG-400

- Formula calcolo larghezza ante **senza** catenaccioli o serrature e **senza** montanti laterali LG-508
- Glass calculation **without** locking bolts or locks and **without** "U" side profile LG-508
- Glasberechnung **ohne** Feststellriegel bzw. Schloss und **ohne** "U"-seitliches Profil LG-508

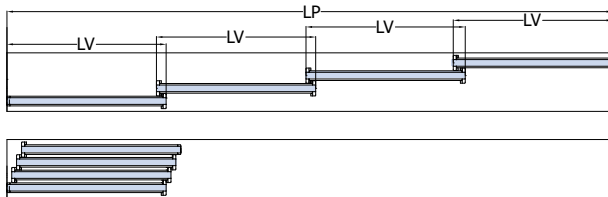

#### SET 4

$$LV = LP / 4$$

$$LV \text{ Anta Laterale A} = LV + 13$$

$$LV \text{ Anta Centrale B} = LV + 13$$

#### SET 4 + SET 4

$$LV = LP / 8$$

$$LV \text{ Anta Laterale A} = LV + 13$$

$$LV \text{ Anta Centrale B} = LV + 13$$

### LG-400

- Formula calcolo larghezza ante **senza** catenaccioli e **senza** montanti laterali LG-508, **con** serratura V-784
- Glass calculation **without** locking bolts and **without** "U" side profile LG-508, **with** locks V-784
- Glasberechnung **ohne** Feststellriegel und **ohne** "U"-seitliches Profil LG-508, **mit** Schloss V-784

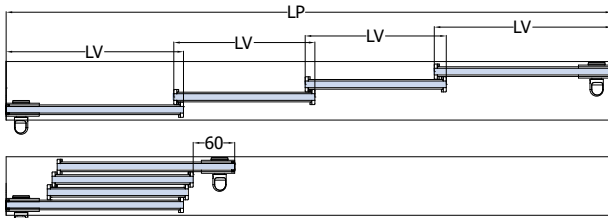

#### SET 4

$$LV = LP / 4$$

$$LV \text{ Anta Laterale A} = LV + 43$$

$$LV \text{ Anta Centrale B} = LV - 17$$

#### SET 4 + SET 4

$$LV = LP / 8$$

$$LV \text{ Anta Laterale A} = LV + 43$$

$$LV \text{ Anta Centrale B} = LV - 17$$

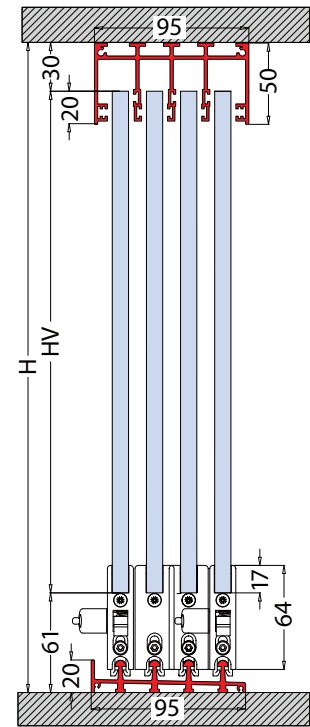

$$HV = H - 91$$

### LG-410

- Set con guida inferiore incassata
- Set with recessed floor profile
- Set mit versenkter Bodenschiene

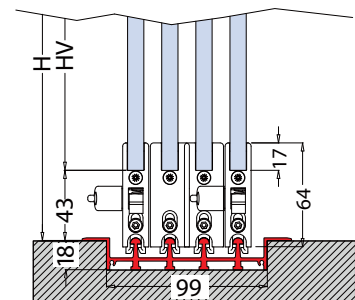

$$HV = H - 73$$

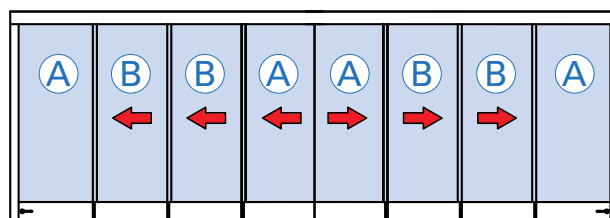
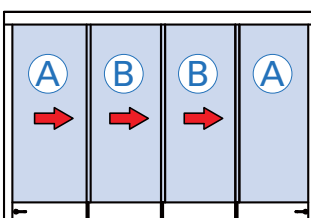

**LP**  
Passaggio luce  
Clear opening width  
Lichte Durchgangsbreite

**LV**  
Larghezza vetro  
Glass width  
Glas Breite

**H**  
Altezza passaggio luce  
Clear opening height  
Lichte Durchgangshöhe

**HV**  
Altezza vetro  
Glass height  
Glas Höhe

# LOGGIAGLAS LG-400 SET 5

## CALCOLO VETRI / GLASS CALCULATION / GLASBERECHNUNG

**C1\*** = con 1 catenacciolo / with 1 locking bolt / mit 1 Feststellriegel / **C2\*** = con 2 catenaccioli / with 2 locking bolts / mit 2 Feststellriegel

### LG-400-C1/C2\*

- Formula calcolo larghezza ante **con** catenaccioli o serrature e **con** montanti laterali LG-508
- Glass calculation **with** locking bolts or locks and **with** "U" side profile LG-508
- Glasberechnung **mit** Feststellriegel oder Schloss und **mit** "U"-seitlichem Profil LG-508

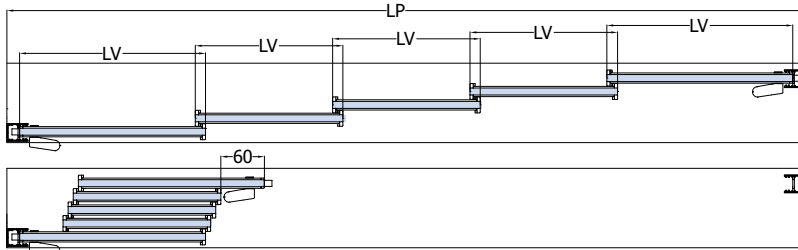

#### SET 5

$$LV = LP / 5$$

$$LV \text{ Anta Laterale A} = LV + 41$$

$$LV \text{ Anta Centrale B} = LV - 19$$

#### SET 5 + SET 5

$$LV = LP / 10$$

$$LV \text{ Anta Laterale A} = LV + 45$$

$$LV \text{ Anta Centrale B} = LV - 15$$

### LG-400

- Formula calcolo larghezza ante **senza** catenaccioli o serrature e **senza** montanti laterali LG-508
- Glass calculation **without** locking bolts or locks and **without** "U" side profile LG-508
- Glasberechnung **ohne** Feststellriegel bzw. Schloss und **ohne** "U"-seitliches Profil LG-508

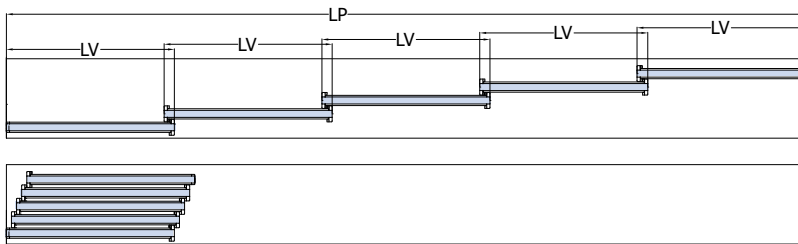

#### SET 5

$$LV = LP / 5$$

$$LV \text{ Anta Laterale A} = LV + 13$$

$$LV \text{ Anta Centrale B} = LV + 13$$

#### SET 5 + SET 5

$$LV = LP / 10$$

$$LV \text{ Anta Laterale A} = LV + 13$$

$$LV \text{ Anta Centrale B} = LV + 13$$

### LG-400

- Formula calcolo larghezza ante **senza** catenaccioli e **senza** montanti laterali LG-508, **con** serratura V-784
- Glass calculation **without** locking bolts and **without** "U" side profile LG-508, **with** locks V-784
- Glasberechnung **ohne** Feststellriegel und **ohne** "U"-seitliches Profil LG-508, **mit** Schloss V-784

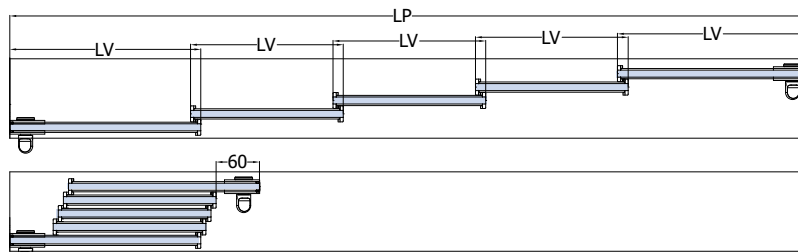

#### SET 5

$$LV = LP / 5$$

$$LV \text{ Anta Laterale A} = LV + 49$$

$$LV \text{ Anta Centrale B} = LV - 11$$

#### SET 5 + SET 5

$$LV = LP / 10$$

$$LV \text{ Anta Laterale A} = LV + 49$$

$$LV \text{ Anta Centrale B} = LV - 11$$

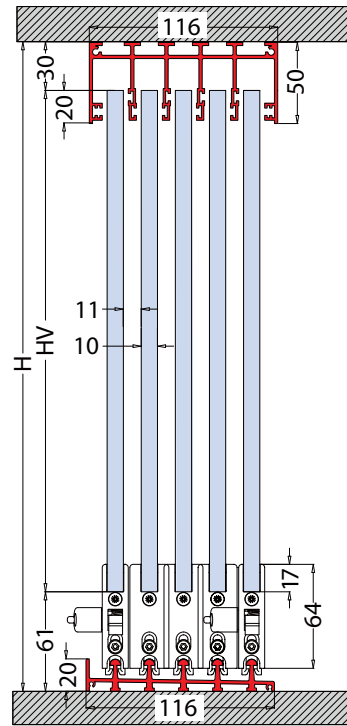

$$HV = H - 91$$

### LG-410

- Set con guida inferiore incassata
- Set with recessed floor profile
- Set mit versenkter Bodenschiene

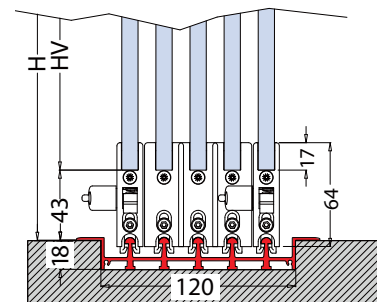

$$HV = H - 73$$

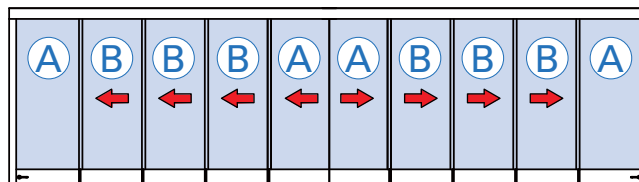
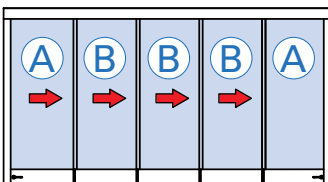

**LP**  
Passaggio luce  
Clear opening width  
Lichte Durchgangsbreite











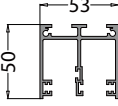

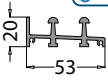

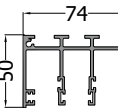

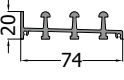

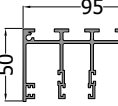
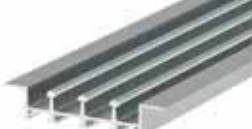
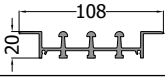

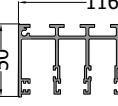

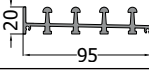

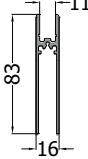

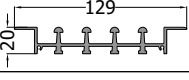

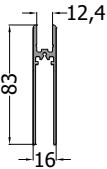
**LV**  
Larghezza vetro  
Glass width  
Glas Breite

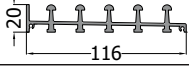
**H**  
Altezza passaggio luce  
Clear opening height  
Lichte Durchgangshöhe

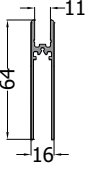
**HV**  
Altezza vetro  
Glass height  
Glas Höhe

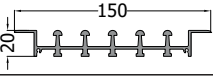
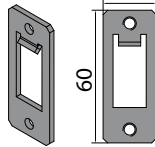
# LOGGIAGLAS

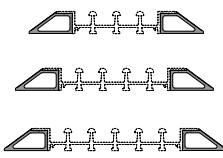
## ACCESSORI / ACCESSORIES / ZUBEHÖRE

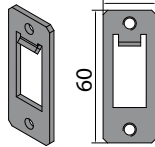
 <p><b>LG-528</b> <span>€▶ C.332</span></p> <ul style="list-style-type: none"> <li>• Binario superiore 2 vie, setola non inclusa</li> <li>• Track profile 2-ways, brush seal not included</li> <li>• Laufschienenprofil 2-gleisig, Bürstendichtungen nicht enthalten</li> </ul> 	 <p><b>LG-529</b> <span>€▶ C.333</span></p> <ul style="list-style-type: none"> <li>• Guida inferiore 2 vie</li> <li>• Floor profile 2-ways</li> <li>• Bodenschiene 2-gleisig</li> </ul> 
 <p><b>LG-501</b> <span>€▶ C.334</span></p> <ul style="list-style-type: none"> <li>• Binario superiore 3 vie, setola non inclusa</li> <li>• Track profile 3-ways, brush seal not included</li> <li>• Laufschienenprofil 3-gleisig, Bürstendichtungen nicht enthalten</li> </ul> 	 <p><b>LG-502</b> <span>€▶ C.335</span></p> <ul style="list-style-type: none"> <li>• Guida inferiore 3 vie</li> <li>• Floor profile 3-ways</li> <li>• Bodenschiene 3-gleisig</li> </ul> 
 <p><b>LG-504</b> <span>€▶ C.337</span></p> <ul style="list-style-type: none"> <li>• Binario superiore 4 vie, setola non inclusa</li> <li>• Track profile 4-ways, brush seal not included</li> <li>• Laufschienenprofil 4-gleisig, Bürstendichtungen nicht enthalten</li> </ul> 	 <p><b>LG-503</b> <span>€▶ C.336</span></p> <ul style="list-style-type: none"> <li>• Guida inferiore incassata 3 vie</li> <li>• Recessed floor profile 3-ways</li> <li>• Versenkte Bodenschiene 3-gleisig</li> </ul> 
 <p><b>LG-513</b> <span>€▶ C.340</span></p> <ul style="list-style-type: none"> <li>• Binario superiore 5 vie, setola non inclusa</li> <li>• Track profile 5-ways, brush seal not included</li> <li>• Laufschienenprofil 5-gleisig, Bürstendichtungen nicht enthalten</li> </ul> 	 <p><b>LG-506</b> <span>€▶ C.338</span></p> <ul style="list-style-type: none"> <li>• Guida inferiore 4 vie</li> <li>• Floor profile 4-ways</li> <li>• Bodenschiene 4-gleisig</li> </ul> 
 <p><b>LG-505</b> <span>€▶ C.343</span></p> <ul style="list-style-type: none"> <li>• Profilo anta per sistemi LG-500, per vetro 8/10 mm. Foro catenacciolo a carico cliente</li> <li>• Horizontal panel profile for systems LG-500 for glass 8/10 mm. Hole for locking bolt by customer</li> <li>• Horizontal Profil für Türen für Systeme LG-500 für Glas 8/10 mm. Bohrung für Feststeller bauseits</li> </ul> 	 <p><b>LG-507</b> <span>€▶ C.339</span></p> <ul style="list-style-type: none"> <li>• Guida inferiore incassata 4 vie</li> <li>• Recessed floor profile 4-ways</li> <li>• Versenkte Bodenschiene 4-gleisig</li> </ul> 
 <p><b>LG-505-12</b> <span>€▶ C.344</span></p> <ul style="list-style-type: none"> <li>• Profilo anta per sistemi LG-500, per vetro 12 mm. Foro catenacciolo a carico cliente</li> <li>• Horizontal panel profile for systems LG-500 for glass 12 mm. Hole for locking bolt by customer</li> <li>• Horizontal Profil für Türen für Systeme LG-500 für Glas 12 mm. Bohrung für Feststeller bauseits</li> </ul> 	 <p><b>LG-514</b> <span>€▶ C.341</span></p> <ul style="list-style-type: none"> <li>• Guida inferiore 5 vie</li> <li>• Floor profile 5-ways</li> <li>• Bodenschiene 5-gleisig</li> </ul> 
 <p><b>LG-405</b> <span>€▶ C.345</span></p> <ul style="list-style-type: none"> <li>• Profilo anta per sistemi LG-400, per vetro 8/10 mm. Foro catenacciolo a carico cliente</li> <li>• Horizontal panel profile for systems LG-400 for glass 8/10 mm. Hole for locking bolt by customer</li> <li>• Horizontal Profil für Türen für Systeme LG-400 für Glas 8/10 mm. Bohrung für Feststeller bauseits</li> </ul> 	 <p><b>LG-515</b> <span>€▶ C.342</span></p> <ul style="list-style-type: none"> <li>• Guida inferiore incassata 5 vie</li> <li>• Recessed floor profile 5-ways</li> <li>• Versenkte Bodenschiene 5-läufig</li> </ul> 
 <p><b>LG-516-B</b> <span>€▶ C.366</span></p> <ul style="list-style-type: none"> <li>• Contropiastra per serratura V-784 e catenacciolo con montante LG-508</li> <li>• Strike plate for lock V-784 and locking bolt with "U" side profile LG-508</li> <li>• Schließblech für Schloss V-784 und Feststeller mit "U"-seitlichem Profil LG-508</li> </ul>	 <p><b>LG-508</b> <span>€▶ C.346</span></p> <ul style="list-style-type: none"> <li>• Montante laterale ad "U", setola non inclusa</li> <li>• "U" side profile, brush seals not included</li> <li>• "U"-seitliches Profil, Bürstendichtungen nicht enthalten</li> </ul> 
 <p><b>LG-527-CF2</b> <span>€▶ C.347</span></p> <ul style="list-style-type: none"> <li>• Scivolo per LG-503, LG-507 e LG-515</li> <li>• Ramp for LG-503, LG-507 and LG-515</li> <li>• Rampe für LG-503, LG-507 und LG-515</li> </ul> 	 <p><b>LG-516-B</b> <span>€▶ C.366</span></p> <ul style="list-style-type: none"> <li>• Contropiastra per serratura V-784 e catenacciolo con montante LG-508</li> <li>• Strike plate for lock V-784 and locking bolt with "U" side profile LG-508</li> <li>• Schließblech für Schloss V-784 und Feststeller mit "U"-seitlichem Profil LG-508</li> </ul>

## LOGGIAGLAS LG-500

### CARRELLI / ROLLERS / LAUFWAGEN

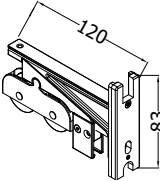
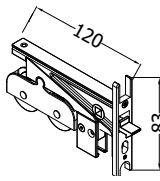
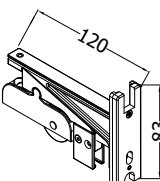
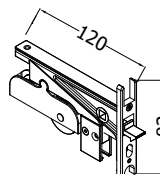
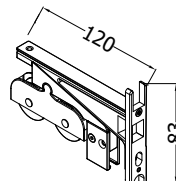
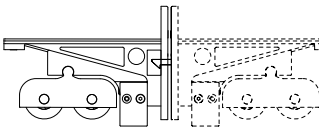
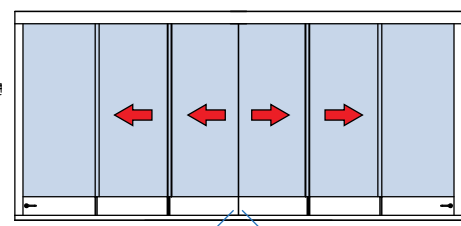
 <p><b>LG-509</b> <span style="float: right;">€▶ C.348</span>  <b>LG-509-12 (for glass 12 mm)</b></p> <ul style="list-style-type: none"> <li>• Carrello con bilanciere a 2 ruote con funzione di trascinamento</li> <li>• Seesaw roller with 2 wheels and with dragging function</li> <li>• Wippenlaufwagen mit 2 Räder und mit Mitnehmer Funktion</li> </ul>	 <p><b>LG-510</b> <span style="float: right;">€▶ C.349</span>  <b>LG-510-12 (for glass 12 mm)</b></p> <ul style="list-style-type: none"> <li>• Catenacciolo / carrello con bilanciere a 2 ruote</li> <li>• Locking bolt seesaw roller with 2 wheels</li> <li>• Feststeller Wippenlaufwagen mit 2 Räder</li> </ul>
 <p><b>LG-519</b> <span style="float: right;">€▶ C.350</span></p> <ul style="list-style-type: none"> <li>• Carrello con 1 ruota con funzione di trascinamento</li> <li>• Roller with 1 wheel and with dragging function</li> <li>• Laufwagen mit 1 Rad und mit Mitnehmer Funktion</li> </ul>	 <p><b>LG-520</b> <span style="float: right;">€▶ C.351</span></p> <ul style="list-style-type: none"> <li>• Catenacciolo / carrello a 1 ruota</li> <li>• Locking bolt roller with 1 wheel</li> <li>• Feststeller Laufwagen mit 1 Rad</li> </ul>
<p><b>LG-521</b> <span style="float: right;">€▶ C.352</span></p> <ul style="list-style-type: none"> <li>• Carrello con bilanciere a 2 ruote e contropiastra per catenacciolo LG-510 con set doppio</li> <li>• Seesaw roller with 2 wheels and strike plate for locking bolt LG-510 with double set</li> <li>• Wippenlaufwagen mit 2 Räder und Schließblech für Feststeller LG-510 mit doppel Set</li> </ul> <div style="display: flex; align-items: center; justify-content: space-around;">    </div> <p style="text-align: center;">LG-521      LG-510 not included</p> <p style="text-align: center;">LG-521    LG-510</p>	

## LOGGIAGLAS LG-400

### CARRELLI / ROLLERS / LAUFWAGEN

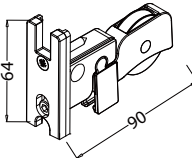
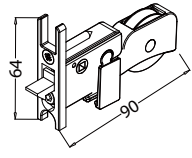
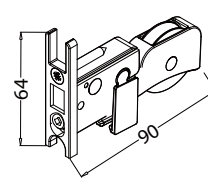
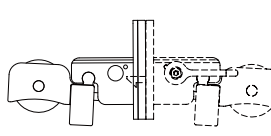
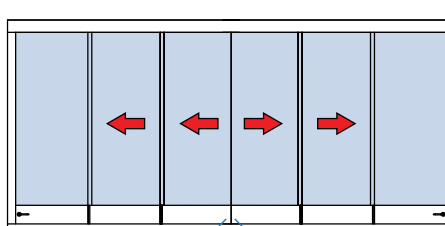
 <p><b>LG-409</b> <span style="float: right;">€▶ C.353</span></p> <ul style="list-style-type: none"> <li>• Carrello con 1 ruota con funzione di trascinamento</li> <li>• Roller with 1 wheel and with dragging function</li> <li>• Laufwagen mit 1 Rad und mit Mitnehmer Funktion</li> </ul>	 <p><b>LG-410</b> <span style="float: right;">€▶ C.354</span></p> <ul style="list-style-type: none"> <li>• Catenacciolo / carrello con 1 ruota</li> <li>• Locking bolt roller with 1 wheel</li> <li>• Feststeller Laufwagen mit 1 Rad</li> </ul>
<p><b>LG-421</b> <span style="float: right;">€▶ C.355</span></p> <ul style="list-style-type: none"> <li>• Carrello con 1 ruota e contropiastra per catenacciolo LG-410 con set doppio</li> <li>• Roller with 1 wheel and strike plate for locking bolt LG-410 with double set</li> <li>• Laufwagen mit 1 Rad und Schließblech für Feststeller LG-410 mit doppel Set</li> </ul> <div style="display: flex; align-items: center; justify-content: space-around;">    </div> <p style="text-align: center;">LG-421      LG-410 not included</p> <p style="text-align: center;">LG-421    LG-410</p>	

# LOGGIAGLAS

## ACCESSORI / ACCESSORIES / ZUBEHÖRE

### LG-517

€ C.358

- Chiave di manutenzione sgancio ante dal sistema antisollevamento
- Maintenance tool to release the panels from the anti-lifting mechanism
- Revisionswerkzeug um die Türen aus dem Aushebeschutzsystem zu anheben

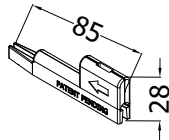

### LG-511

€ C.357

- Pomolo singolo per catenacciolo
- Single knob for locking bolt
- Knopf für Feststeller

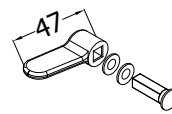

### LG-512

€ C.357

- Pomolo doppio per catenacciolo
- Double knob for locking bolt
- Paar Knöpfe für Feststeller

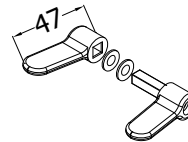

### LG-526

€ C.360

#### (CONSIGLIATO - RECOMMENDED - EMPFOHLEN)

- Set di 3 pcs "U" trasparenti per incollaggio perpendicolare vetro 10 mm al profilo anta LG-505 e LG-405
- Set of 3 pcs transparent "U" support for perpendicular glueing of 10 mm glass to panel profile LG-505 end LG-405
- Set von 3 Stück transparenten U-Auflagen für 10 mm Glas zum passgenauen senkrechten einkleben ins Flügelprofil LG-505 und LG-405

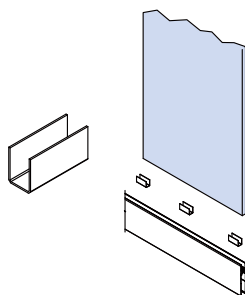

### LG-426

€ C.361

#### (CONSIGLIATO - RECOMMENDED - EMPFOHLEN)

- Set di 3 pcs "U" trasparenti per incollaggio perpendicolare vetro 8 mm al profilo anta LG-405
- Set of 3 pcs transparent "U" support for perpendicular glueing of 8 mm glass to panel profile LG-405
- Set von 3 Stück transparenten U-Auflagen für 8 mm Glas zum passgenauen senkrechten einkleben ins Flügelprofil LG-405

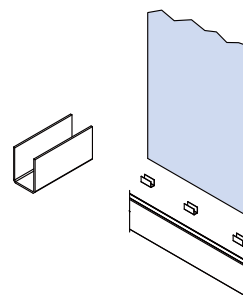

### LG-518

€ C.359

- Guarnizione in PVC trasparente per vetro 8/10 mm
- Seal in transparent PVC for glass 8/10 mm
- PVC Dichtprofil für Glas 8/10 mm

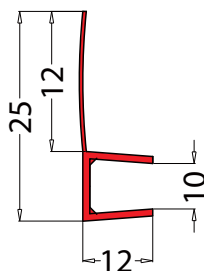

### V-040-REG

€ C.372

- Guarnizione per vetro 12 mm aletta laterale accorciabile
- Seal for glass 12 mm, side fin can be shortened
- Dichtprofil für Glas 12 mm seitliche Lippe kürzbar

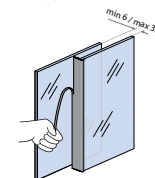
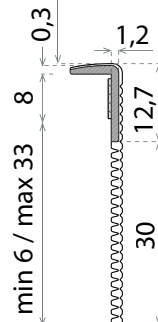

### LG-533

€ C.369

- Sistema scarico acqua laterale per guida inferiore 3 vie
- Side drainage system for 3-ways floor profile
- Seitliches Entwässerungssystem für 3-gleisige Bodenschiene

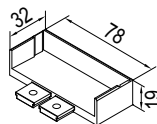

### LG-534

€ C.370

- Sistema scarico acqua laterale per guida inferiore 4 vie
- Side drainage system for 4-ways floor profile
- Seitliches Entwässerungssystem für 4-gleisige Bodenschiene

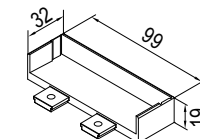

### LG-535

€ C.371

- Sistema scarico acqua laterale per guida inferiore 5 vie
- Side drainage system for 5-ways floor profile
- Seitliches Entwässerungssystem für 5-gleisige Bodenschiene

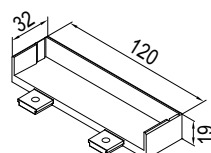





# LOGGIAGLAS

## ACCESSORI / ACCESSORIES / ZUBEHÖRE

### V-784

€▶ C.373

- Serratura con gancio per scorrevole. Contropiastra non inclusa
  - Lock with hook for sliding doors. Strike plate not included
  - Schloss mit Hakenriegel für Schiebetüren. Schließblech nicht enthalten.
- CP - NS - CR

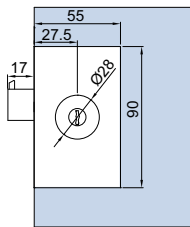

Senza viti a vista  
With not visible screws  
Ohne sichtbare Schrauben

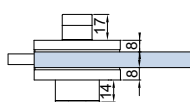

### V-784 PO-TC

€▶ C.374

- Serratura con gancio per scorrevole. Contropiastra non inclusa
  - Lock with hook for sliding doors. Strike plate not included
  - Schloss mit Hakenriegel für Schiebetüren. Schließblech nicht enthalten.
- CP - NS

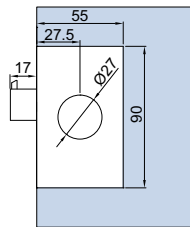

Senza viti a vista  
With not visible screws  
Ohne sichtbare Schrauben

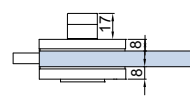

### V-769-2FLG

€▶ C.380

- Controserratura
  - Strike box
  - Gegenkasten
- CP

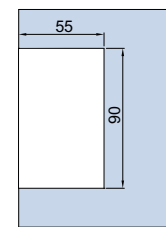

Con viti a vista  
With visible screws  
Mit sichtbaren Schrauben

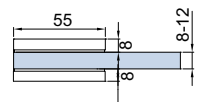

### V-784-LG90-400 (Kit for LG-400)

€▶ A.382

### V-784-LG90-500 (Kit for LG-500)

- Controserratura 90° per serrature V-794, V-784, V-764, V-564 e V-574, comprese staffe 90° e tappi per giunzione profili
- Strike box 90° for locks V-794, V-784, V-764, V-564 and V-574, brackets 90° and endcaps for connecting the profiles included
- Gegenkasten 90° für Schlösser V-794, V-784, V-764, V-564 und V-574, Verbinder 90° und Endkappen für Profile enthalten

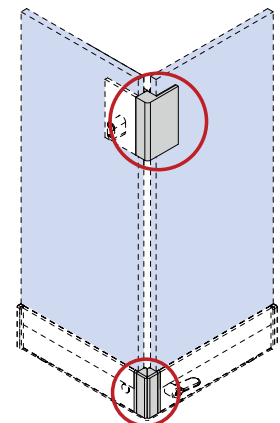
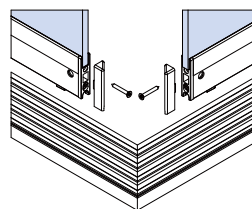
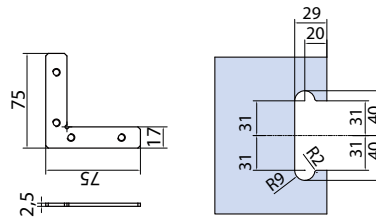
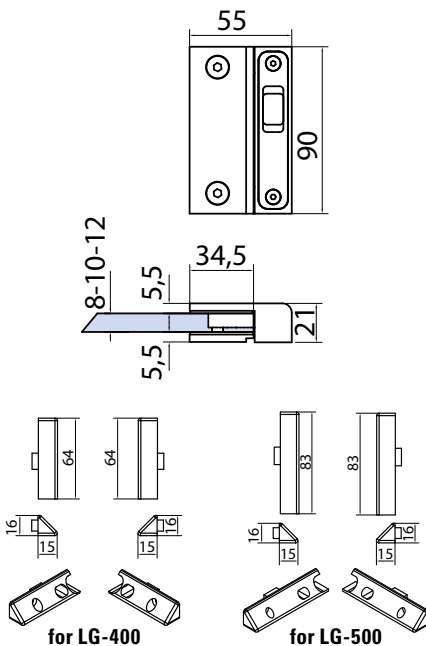

### V-524

€▶ C.367

- Paio nicchie per scorrevole tonde, Ø 60
  - Pair sliding door-handles, Ø 60
  - Paar Griffmuscheln, Ø 60
- CP - NS - NO

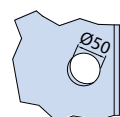

### V-532-INC

€▶ A.368

- Nicchia scorrevole ad incollaggio biadesivo Ø 50
- Sliding door-handle Ø 50 with self adhesive
- Griffmuschel Ø 50 selbstklebend

AN - NS

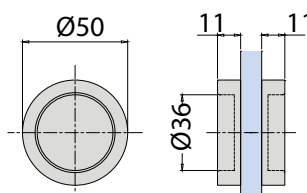

- |  |  |   |
|--|--|---|
| <p><b>V-764</b> <span style="float: right;">€▶ C.378</span></p> <ul style="list-style-type: none"> <li>Serratura con gancio per scorrevole. Contropiastra non inclusa</li> <li>Lock with hook for sliding doors. Strike plate not included</li> <li>Schloss mit Hakenriegel für Schiebetüren. Schließblech nicht enthalten.</li> </ul> <p>CP</p> | <p><b>V-764 PO-TC</b> <span style="float: right;">€▶ C.379</span></p> <ul style="list-style-type: none"> <li>Serratura con gancio per scorrevole. Contropiastra non inclusa</li> <li>Lock with hook for sliding doors. Strike plate not included</li> <li>Schloss mit Hakenriegel für Schiebetüren. Schließblech nicht enthalten.</li> </ul> <p>CP</p> | <p><b>V-769-2FLG</b> <span style="float: right;">€▶ C.375</span></p> <ul style="list-style-type: none"> <li>Controserratura</li> <li>Strike box</li> <li>Gegenkasten</li> </ul> <p>CP</p> |
|--|--|---|

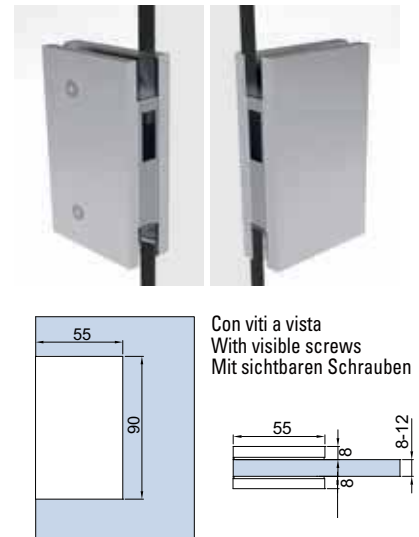
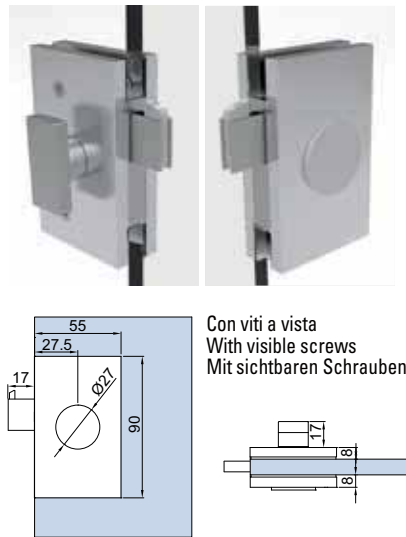
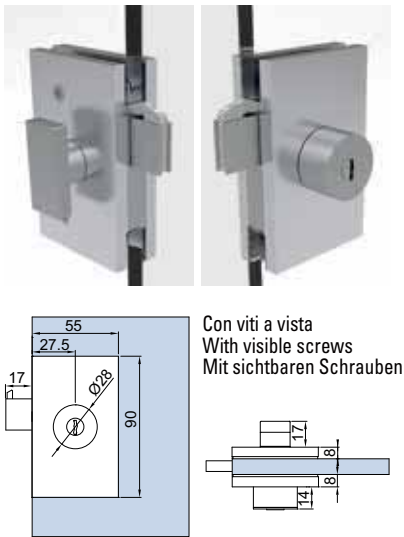

- |  |   |   |
|--|---|---|
| <p><b>V-794</b> <span style="float: right;">€▶ C.383</span></p> <ul style="list-style-type: none"> <li>Serratura con gancio per scorrevole. Contropiastra non inclusa</li> <li>Lock with hook for sliding doors. Strike plate not included</li> <li>Schloss mit Hakenriegel für Schiebetüren. Schließblech nicht enthalten.</li> </ul> <p>NS</p> | <p><b>V-794-LG</b> <span style="float: right;">€▶ C.384</span></p> <ul style="list-style-type: none"> <li>Serratura con gancio per scorrevole. Contropiastra non inclusa</li> <li>Lock with hook for sliding doors. Strike plate not included</li> <li>Schloss mit Hakenriegel für Schiebetüren. Schließblech nicht enthalten.</li> </ul> <p>NS</p> | <p><b>V-794-2FLG</b> <span style="float: right;">€▶ C.385</span></p> <ul style="list-style-type: none"> <li>Controserratura</li> <li>Strike box</li> <li>Gegenkasten</li> </ul> <p>NS</p> |
|--|---|---|

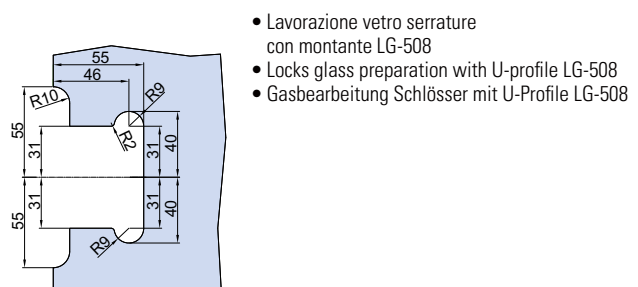
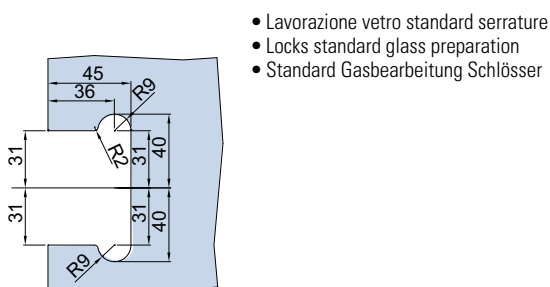
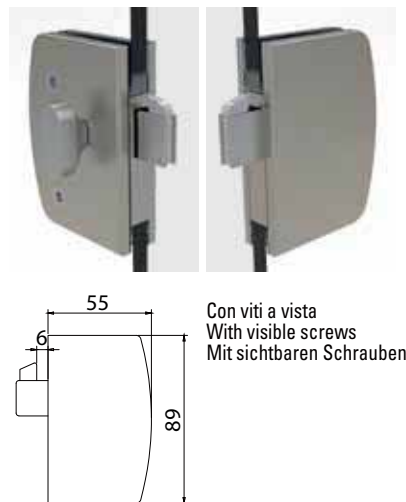
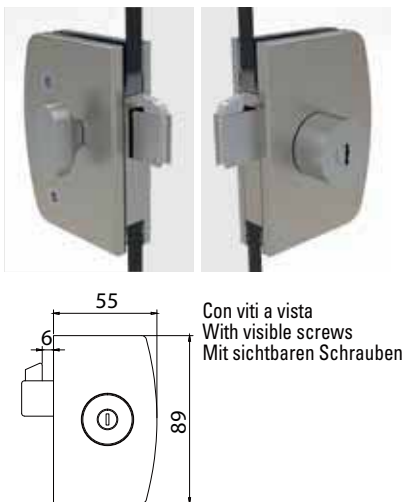

## ALCUNE TIPOLOGIE DI APPLICAZIONE

*SOME TYPOLOGIES OF APPLICATIONS*

*EINIGEN KOMPOSITIONSMÖGLIHEITEN DES SYSTEM*





## ALCUNE TIPOLOGIE DI APPLICAZIONE

*SOME TYPOLOGIES OF APPLICATIONS*

*EINIGEN KOMPOSITIONSMÖGLIKEITEN DES SYSTEM*





## ALCUNE TIPOLOGIE DI APPLICAZIONE

*SOME TYPOLOGIES OF APPLICATIONS*

*EINIGEN KOMPOSITIONSMÖGLIKEITEN DES SYSTEM*







Le informazioni tecniche in questo catalogo potrebbero non sempre corrispondere con gli attuali colori, misure e dimensioni. Noi perseguiamo una politica di costante innovazione e miglioramento e ci riserviamo il diritto di modificare specifiche e disponibilità senza preavviso. Non abbiamo nessuna responsabilità per errori di stampa che possono essere occorsi nella realizzazione di questo catalogo. Essendo questo solo un catalogo grafico per la foratura del vetro bisogna fare riferimento al manuale tecnico.

Please note that the technical information included in this catalogue may not always precisely correspond with actual colours, measurements and dimensions. We pursue a policy of constant updating and improvement and reserve the right to alter specification and availability without notice. We take no responsibility for any printing errors that might be occurred in the completion of this catalogue.

Die in diesem Katalog angegebenen Maße, Abbildungen und Angaben, sind unverbindlich. Modelländerungen, Konstruktionsverbesserungen und Maßänderungen behalten wir uns vor. Erfahrungsgemäß können Druckfarben nicht immer den Farbton original getreu wiedergeben. Farbabweichungen sind daher möglich. Für Druckfehler wie auch übrige Fehler welche bei Erstellung dieses Kataloges entstanden sind, ist jede Haftung ausgeschlossen.

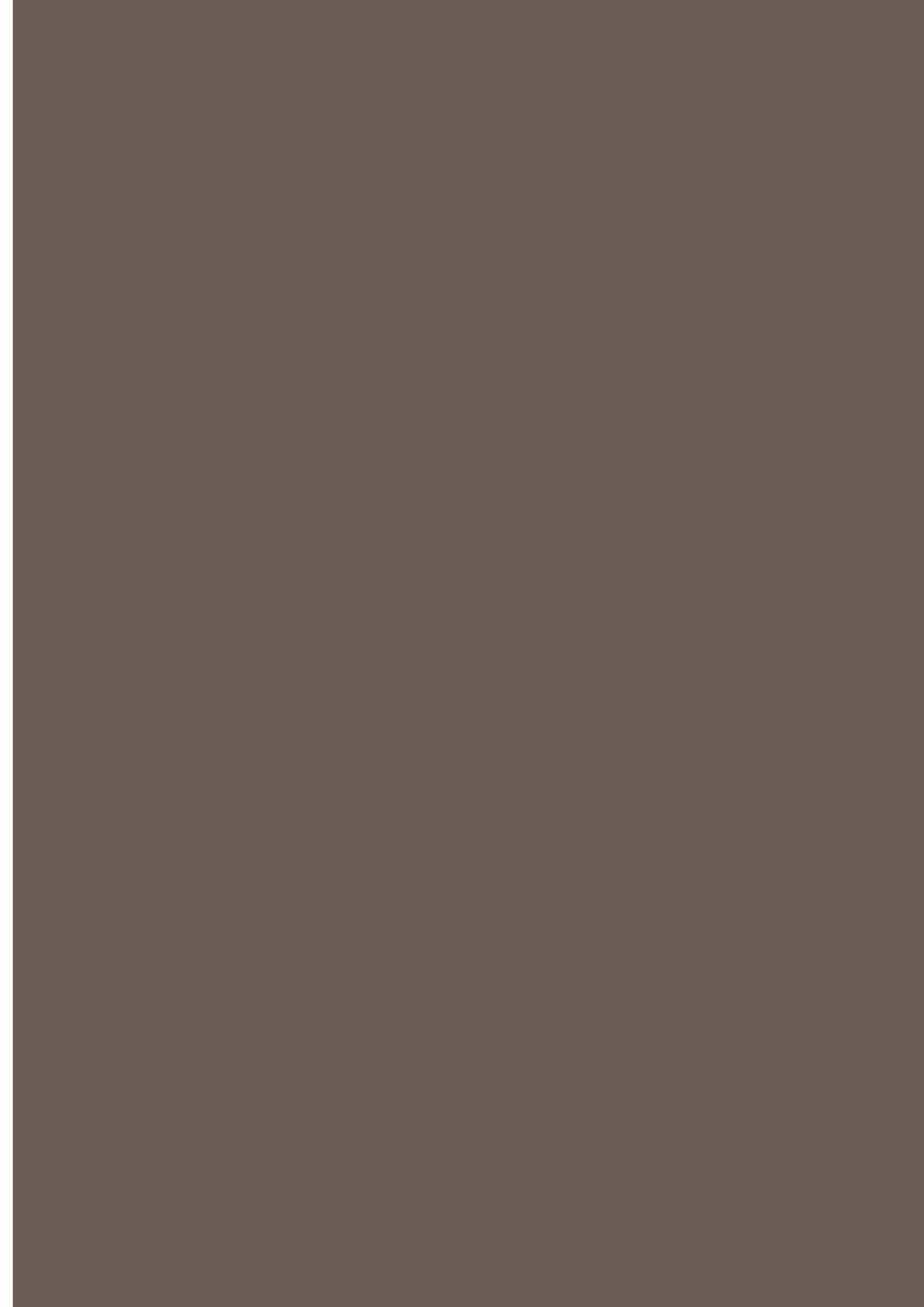



**METALGLAS BONOMI srl**

Via Montini, 106/A - 25067 Lumezzane S.A. (Brescia) Italy  
Ph. +39 030 829910 - Fax +39 030 8920970  
[www.metalglas.it](http://www.metalglas.it) - [info@metalglas.it](mailto:info@metalglas.it)