

INDOOR

PARETI DIVISORIE E STIPITI
PARTITION WALLS AND FRAMES
TRENNWÄNDE UND ALUMINIUMZARGEN

D

SERRATURE E CERNIERE
LOCKS AND HINGES
SCHLÖSSER UND BÄNDER

E

MANIGLIE MANIGLIONI POMOLI
DOORHANDLES PULLHANDLES KNOBS
TÜRGRIFFE STOSSGRIFFE KNÖPFE

F

PORTE ESTERNE
PATCH FITTINGS
GANZGLASANLAGEN

G



01/2020



INDOOR

INDICE / INDEX / INHALT



I NUOVI CATALOGHI METALGLAS BONOMI E I NUOVI LISTINI	2
<i>THE NEW CATALOGS METALGLAS BONOMI AND NEW PRICE LISTS</i>	
<i>DIE NEUEN KATALOGE METALGLAS BONOMI UND NEUE PREISLISTEN</i>	
DAL CATALOGO AL LISTINO CON UN SEMPLICE CODICE	4
<i>FROM THE CATALOG TO THE LIST WITH A SIMPLE CODE</i>	
<i>VOM KATALOG ZUR LISTE MIT EINEM EINFACHEN CODE</i>	
LEGENDA SIMBOLI	6
<i>SYMBOL LEGEND</i>	
<i>SYMBOLLEGENDE</i>	
LEGENDA ABBREVIAZIONI	7
<i>ACRONYM LEGEND</i>	
<i>ERKLÄRUNG DER ABKÜRZUNGEN</i>	
FINITURE	7
<i>FINISHES</i>	
<i>OBERFLÄCHEN</i>	
<hr/>	
D PARETI DIVISORIE E STIPITI	8
<i>PARTITION WALLS AND FRAMES</i>	
<i>TRENNWÄNDE UND ALUMINIUMZARGEN</i>	
GUIDA TECNICA PER LA SCELTA DEL VOSTRO SISTEMA	10
<i>TECHNICAL GUIDE FOR THE CHOICE OF YOUR SYSTEM</i>	
<i>AUSWAHL VON SCHIEBETÜRSYSTEME NACH VORHANDENEN KRITERIEN</i>	
E SERRATURE E CERNIERE	62
<i>LOCKS AND HINGES</i>	
<i>SCHLÖSSER UND BÄNDER</i>	
GUIDA TECNICA PER LA SCELTA DEL VOSTRO SISTEMA	64
<i>TECHNICAL GUIDE FOR THE CHOICE OF YOUR SYSTEM</i>	
<i>AUSWAHL VON SCHIEBETÜRSYSTEME NACH VORHANDENEN KRITERIEN</i>	
F MANIGLIE MANIGLIONI POMOLI	150
<i>DOORHANDLES PULLHANDLES KNOBS</i>	
<i>TÜRGRIFFE STOSSGRIFFE KNÖPFE</i>	
GUIDA TECNICA PER LA SCELTA DEL VOSTRO SISTEMA	152
<i>TECHNICAL GUIDE FOR THE CHOICE OF YOUR SYSTEM</i>	
<i>AUSWAHL VON SCHIEBETÜRSYSTEME NACH VORHANDENEN KRITERIEN</i>	
G PORTE ESTERNE	178
<i>PATCH FITTINGS</i>	
<i>GANZGLASANLAGEN</i>	
GUIDA TECNICA PER LA SCELTA DEL VOSTRO SISTEMA	180
<i>TECHNICAL GUIDE FOR THE CHOICE OF YOUR SYSTEM</i>	
<i>AUSWAHL VON SCHIEBETÜRSYSTEME NACH VORHANDENEN KRITERIEN</i>	

I NUOVI CATALOGHI METALGLAS BONOMI

THE NEW CATALOGS METALGLAS BONOMI
DIE NEUEN KATALOGE METALGLAS BONOMI



SCORREVOLI

A | SISTEMI SCORREVOLI
SLIDING DOOR SYSTEMS
SCHIEBETÜRSYSTEME



BOX DOCCIA

B | BOX DOCCIA
SHOWER BOX
DUSCHKABINEN



OUTDOOR PARETI MOBILI

C | PARETI MOBILI
SLIDING WALLS
SCHIEBEWÄNDE

... E I NUOVI LISTINI PREZZI
... AND NEW PRICE LISTS
... UND NEUE PREISLISTEN

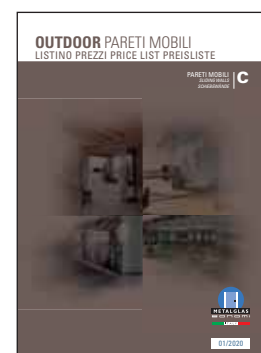
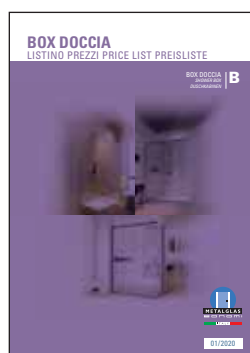



INDOOR

- D** | PARETI DIVISORIE E STIPITI
PARTITION WALLS AND FRAMES
TRENNWÄNDE UND ALUMINIUMZARGEN
- E** | SERRATURE E CERNIERE
LOCKS AND HINGES
SCHLÖSSER UND BÄNDER
- F** | MANIGLIE MANIGLIONI POMOLI
DOORHANDLES PULLHANDLES KNOBS
TÜRGRIFFE STOSSGRIFFE KNÖPFE
- G** | PORTE ESTERNE
PATCH FITTINGS
GANZGLASANLAGEN

OUTDOOR BALAUSTRRE E PENSILINE

- H** | BALAUSTRRE E PENSILINE
RAILING AND CANOPY SYSTEMS
GANZGLASGELÄNDER UND VORDACHSYSTEME
- I** | DISTANZIALI MORSETTI ACCESSORI
POINT FITTINGS CLAMPS ACCESSORIES
PUNKTHALTERUNG KLEMMBEFESTIGUNGEN ZUBEHÖRE



DAL CATALOGO AL LISTINO CON UN SEMPLICE CODICE

FROM THE CATALOG TO THE LIST WITH A SIMPLE CODE
VOM KATALOG ZUR LISTE MIT EINEM EINFACHEN CODE

SEARCH FOR THE CODE
OF EVERY PRODUCT IN
CATALOG...

*(ERCA IL CODICE
DI OGNI PRODOTTO NEL
CATALOGO...)*

SUCHE NACH DEM CODE
VON JEDEM PRODUKT IN
KATALOG ...



P-058 / P-059

PROFILI A SCATTO PER FISSI / CLIP-ON PROFILES FOR FIXED PANELS / KLIPSPROFILE FÜR FESTVERGLASUNGEN



P-065

- Installazione facile e veloce con un...
- Easy and quick installation of glass
- Einfache und schnelle Glasmontage,

€ ▶ D.01

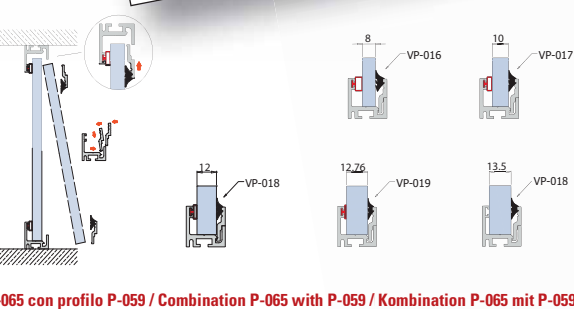

P-065 con profilo P-059 / Combination P-065 with P-059 / Kombination P-065 mit P-059

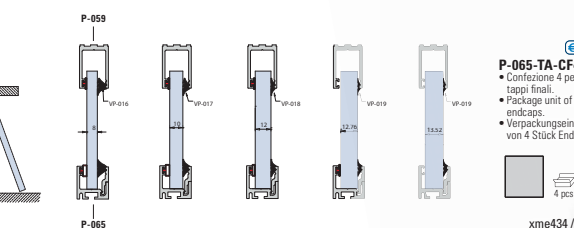

- P-065-TA-CF4** € ▶ D.02
- Confezione 4 pezzi tappi finali.
 - Package unit of 4 pieces endcaps.
 - Verpackungseinheit von 4 Stück Endkappen.



xme434 / x

P-058 con profilo P-059 / Combination P-058 with P-059 / Kombination P-058 mit P-059

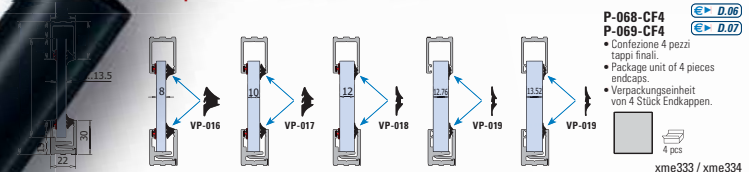

- P-068-CF4** € ▶ D.06
P-069-CF4 € ▶ D.07
- Confezione 4 pezzi tappi finali.
 - Package unit of 4 pieces endcaps.
 - Verpackungseinheit von 4 Stück Endkappen.



xme333 / xme334

D. 01

Q.TÀ	FIN.	EURO	FIN.	EURO
1 pcs	AN	122,50 /pcs		
min 3 pcs	AN	107,70 /pcs		
min 3 pcs	AN	167,00 /pcs		

INDOOR 15/16

Q.TÀ	FIN.	EURO	FIN.	EURO
3000 mm	8 pcs	AN 53,30 /pcs 17,77 /mtl	GR	47,00 /pcs 15,67 /mtl
6000 mm	4 pcs	AN 100,00 /pcs 16,67 /mtl	GR	87,50 /pcs 14,59 /mtl
3000 mm	16 pcs	AN 25,00 /pcs 8,34 /mtl	GR	19,00 /pcs 6,34 /mtl
6000 mm	8 pcs	AN 43,70 /pcs 7,29 /mtl	GR	31,30 /pcs 5,22 /mtl

SECTOR III

IP-065-CART

MINIMO D'ORDINE: 8 profili da 6 mt o 16 profili da 3 mt (o multipli ▲), anche assortiti tra i vari modelli, dello stesso settore di magazzino indicato in tabella (SECTOR).

MINIMUM ORDER: No. 8 - 6 m profiles, or No. 16 - 3 m profiles, or No. 24 - 2 m profiles (or multiples ▲), also in combination of different models, as long as they belong to the same warehouse sector indicated in the table (SECTOR).

MINDESTBESTELLMENGE: 8 Profile mit 6 m oder 16 Profile mit 3 m (nur als Vielfaches ▲), auch sortiert nach den verschiedenen Modellen, aber aus demselben Lagerort, der in der Tabelle angeführt ist (SECTOR).

Q.TÀ	FIN.	EURO	FIN.	EURO
2200 mm	min 24 pcs	6,00 /pcs		

B-146

IB-146-CF140

2200 mm

140 pcs

Q.TÀ	FIN.	EURO	FIN.	EURO
4 pcs	AN			

P-065-TA-CF4

Tappe
Endcap
Endkappe

4 pcs

CF

- Prezzi speciali per l'acquisto delle quantità minime indicate (CF del NB: eventuali riordini o aggiunte per completamenti se di quantità).
- Special prices for the purchase of the minimum quantities indicated (Note Well: any reorders or additions for completions of quantity).
- Artikel mit Sonderpreisen bei Mindestabnahmemengen sind mit Nachbestellungen oder Ergänzungen unter der Mindestabnahme.

POS.	PROD.	ART.
	VP-016	VP-016
	VP-017	VP-017
	VP-018	VP-018
	VP-019	VP-019

Q.TÀ	FIN.	EURO	FIN.	EURO
5 mm				
4 mm				
3 mm				
2 mm				

D. 06

VP-016

VP-016-CF150

VP-017

VP-017-CF250

VP-018

VP-018-CF300

VP-019

VP-019-CF400

... **RITROVERAI VELOCEMENTE
LO STESSO CODICE NEL
LISTINO**

YOU'LL FIND QUICKLY
THE SAME CODE
IN THE PRICE LIST

... SIE FINDEN SCHNELL
DEN GLEICHEN CODE
IN DER PREISLISTE



LEGENDA SIMBOLI

SYMBOL LEGEND

SYMBOLLEGENDE



8-10

SPESSORE VETRO
GLASS THICKNESS
GLASDICKE



1000

MISURE ANTA
PANEL MEASURES
TÜRGRÖSSE



PORTATA
LOAD CAPACITY
TRAGKRAFT



SISTEMA SOFT-CLOSE
SOFT-CLOSE SYSTEM
SOFT-CLOSE SYSTEM



PORTATA DEL SISTEMA SOFT-CLOSE
LOAD CAPACITY OF THE SOFT-CLOSE SYSTEM
TRAGKRAFT DES SOFT-CLOSE SYSTEMS

FIXED

ANTA FISSA
FIXED PANEL
SEITENTEIL



ANTA SCORREVOLE
SLIDING DOOR
SCHIEBETÜR

MY METALGLAS

CONFIGURATORE ESCLUSIVO
METALGLAS PER SEMPLIFICARE
LA REALIZZAZIONE DI SISTEMI
IN VETRO TEMPERATO

EXCLUSIVE CONFIGURATOR METALGLAS
TO SIMPLIFY THE CREATION OF SYSTEMS
IN TEMPERED GLASS

EXKLUSIVER KONFIGURATOR METALGLAS
ZU VEREINFACHEN DIE ERSTELLUNG
VON SYSTEMEN AUS GEHÄRTETEM GLAS

LEGENDA ABBREVIAZIONI

ACRONYM LEGEND

ERKLÄRUNG DER ABKÜRZUNGEN

LP PASSAGGIO LUCE
 CLEAR OPENING WIDTH
 LICHTE DURCHGANGSBREITE

H / HP ALTEZZA PASSAGGIO LUCE
 CLEAR OPENING HEIGHT
 LICHTE DURCHGANGSHÖHE

LM / LA LARGHEZZA ANTA MOBILE
 SLIDING DOOR WIDTH
 SCHIEBEFLÜGEL BREITE

HM / HA ALTEZZA ANTA MOBILE
 SLIDING GLASS HEIGHT
 SCHIEBEFLÜGEL HÖHE

HF ALTEZZA ANTA FISSA
 SIDE FIXED GLASS HEIGHT
 SEITENTEIL HÖHE

LF LARGHEZZA ANTA FISSA
 FIXED GLASS WIDTH
 SEITENTEIL BREITE

LB LUNGHEZZA BINARIO
 RAIL LENGTH
 LAUFSCHIENENLÄNGE

HB ALTEZZA FISSAGGIO BINARIO
 RAIL INSTALLATION HEIGHT
 LAUFSCHIENENMONTAGE HÖHE

LV LARGHEZZA VETRO
 GLASS WIDTH
 GLAS BREITE

HV ALTEZZA VETRO
 GLASS HEIGHT
 GLAS HÖHE

LV LARGHEZZA VETRO
 GLASS WIDTH
 GLAS BREITE

HS ALTEZZA STIPITE
 FRAME HEIGHT
 ZARGE HÖHE

LS LARGHEZZA STIPITE
 FRAME WIDTH
 ZARGE BREITE

FINITURE

FINISHES

OBERFLÄCHEN

 **CP** CROMO PERLA
 CHROME PERLA SIMILAR ALU
 CHROM PERLA ÄHNLICH ALU

 **CS** CROMO SATINATO
 SATIN CHROME
 CHROM MATT

 **NS** NICKEL SATINATO
 SATIN NICKEL
 ÄHNLICH EDELSTAHL MATT

 **CR** CROMO LUCIDO
 POLISHED CHROME
 CHROM GLÄNZEND

 **OL** OTTONE LUCIDO
 POLISHED BRASS
 MESSING POLIERT

 **AN** ALLUMINIO ANODIZZATO
 ALUMINIUM ANODIZED
 ALUMINIUM SILBERFARBIG

 **IX** ACCIAIO INOX SATINATO
 SATIN STAINLESS STEEL
 EDELSTAHL MATT

 **IXE** EFFETTO INOX SATINATO
 INOX EFFECT
 INOX EFFEKT

 **IL** ACCIAIO INOX LUCIDO
 POLISHED STAINLESS STEEL
 EDELSTAHL POLIERT

 **NO** NERO OPACO
 MATT BLACK
 SCHWARZ MATT

PARETI DIVISORIE E STIPITI
PARTITION WALLS AND FRAMES
TRENNWÄNDE UND ALUMINIUMZARGEN

D

GUIDA TECNICA PER LA SCELTA DEL VOSTRO SISTEMA

TECHNICAL GUIDE FOR THE CHOICE OF YOUR SYSTEM
AUSWAHL VON SYSTEME NACH VORHANDENEN KRITERIEN

PROFILI PER VETRI FISSI
PROFILES FOR FIXED PANELS
PROFİL FÜR FESTVERGLASUNGEN



PROFILI A SCATTO
CLIPS-ON PROFILES
KLIPSPROFİL
P-065 / P-01 / P-02
P-058 / P-059 / P-050 / P-055

► 12

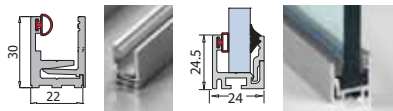

CANALINE "U" IN ALLUMINIO
U PROFILES IN ALUMINIUM
U-PROFİL AUS ALUMINIUM

► 18

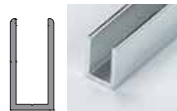

CANALINE IN ACCIAIO
"U" PROFILES IN INOX
"U" PROFİL AUS INOX

► 20



CANALINE "U" CON BORDO RIPIEGATO
"U" PROFILES WITH FOLDED EDGE
"U" PROFİL MIT ABGERUNDET

► 20



CANALINE CON ALETTA
U PROFILES WITH PLATE
U-PROFİL MIT PLATTE

► 21



ANGOLARI
L PROFILES
L PROFİL

► 21



PARETI DIVISORIE CON TRATTA FISSA E STIPITE COORDINATI
PARTITION WALLS WITH COORDINATED FRAMES
TRENWÄNDE MIT KOORDINIERTEN ZARGEN



EASY PARETE
MONOVETRO

► 24

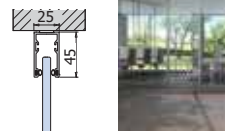

DUAL GLASS
DOPPIO VETRO

► 25

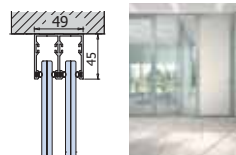

TP-010

► 26

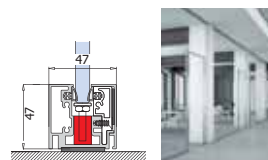

PPS EVOLUTION
MINI SOFT CLOSE

► 27

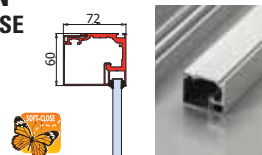

PROFILI IN POLICARBONATO
POLYCARBONATE PROFILES
POLYCARBONATPROFİL

► 28

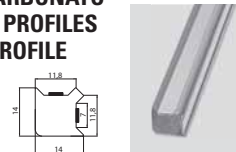

STIPITI SU VETRO
ALUMINIUM FRAMES WITH FIXED SIDE PANELS
ALUZARGEN MIT SEITENTEILEN



TP-201
STIPITE EASY PARETE

► 32

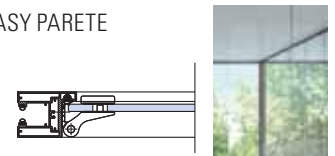

TP-401
STIPITE DUAL GLASS

► 33

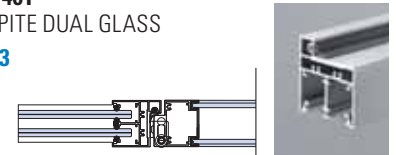

TP-100

► 35

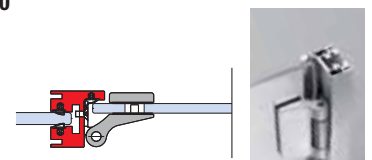

P-030-V

► 36

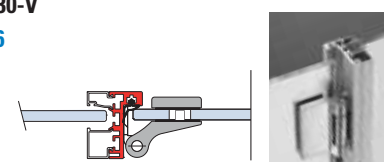

P-080-V

► 37

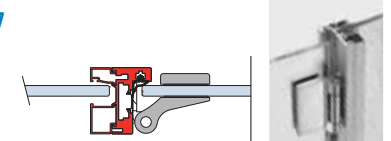

P-085-V

► 38

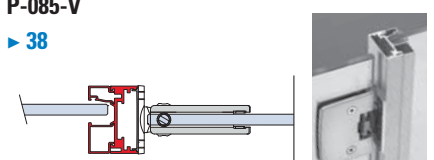

TP-110

► 34

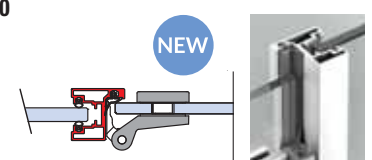

STIPITI SU MURO
ALUMINIUM FRAMES
ALUZARGEN



P-010

► 44

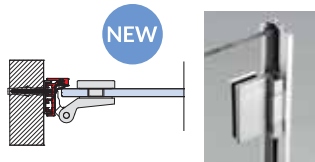

P-030

► 42

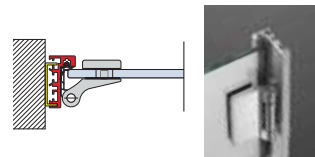

P-080-SL

► 46

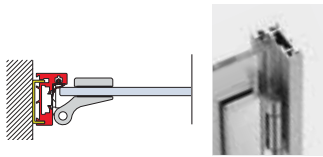

P-040

► 45

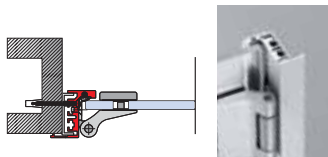

P-085

► 47

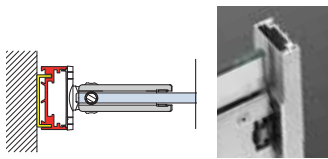

TP-300
IMBOTTE

► 48

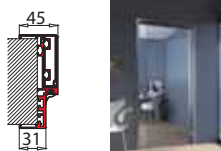

TP-250

► 49

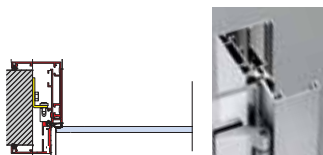

STIPITI RASOMURO E ANTE IN ALLUMINIO
ALIGNED WITH THE WALL FRAMES
AND DOORS WITH ALUMINIUM PANEL
WANDBÜNDIGE ALUZARGE
UND ALUMINIUM FLÜGELRAHMEN



P0-100

► 58



P0-200

► 56

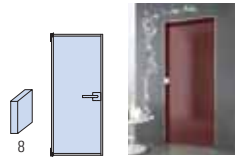

P-060

► 60

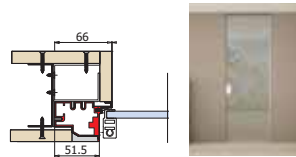

P-070

► 61

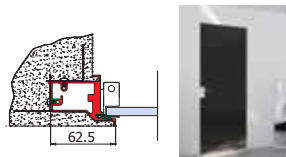

P0-290
BRIXIA

► 51

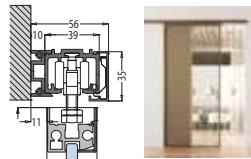

ANTE A SCOMPARSA
FLUSH SLIDING DOORS
SCHIEBETÜREN
IN DER WAND LAUFEND

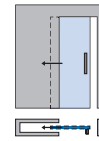

TS-04

► 50

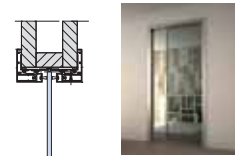

V-1664 / TS-03

► 52 - 51

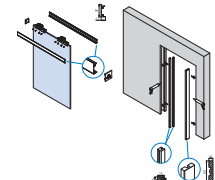

PROFILI PER VETRI FISSI

PROFILES FOR FIXED PANELS
PROFILE FÜR FESTVERGLASUNGEN

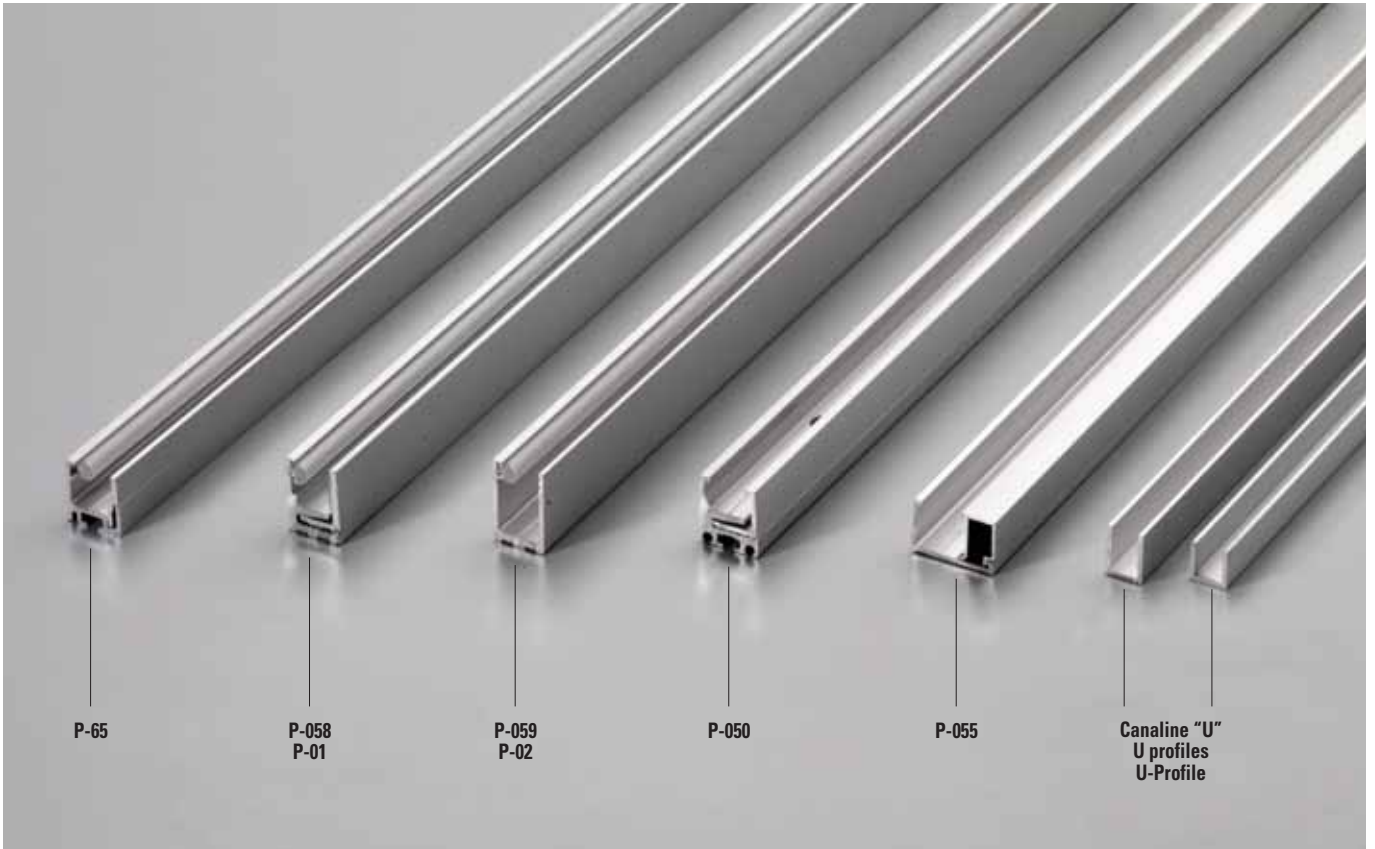

P-065

► 14

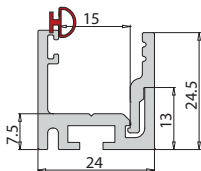

P-058

► 15

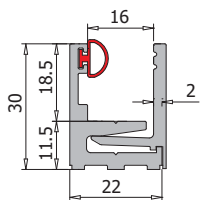

xme334

P-059

► 15

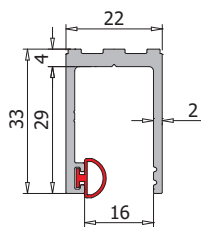

xme333

P-050

► 17

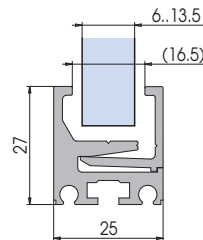

xla223

P-055

► 17

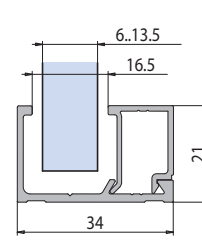

xla224

CANALINE "U"

U PROFILES
U-PROFILE

► 18

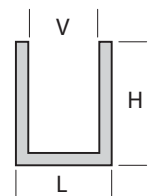

P-01

► 16

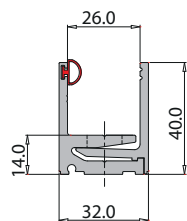

xfb081

P-02

► 16

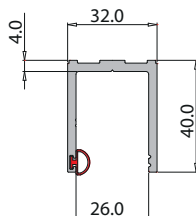

xfb081

- Misure disponibili
 - Available measures
 - Verfügbare Maße
- V-2014 = L 18 H 16 V 14
V-2015 = L 20 H 10 V 16
V-2036 = L 19 H 40 V 14
V-2037 = L 19 H 40 V 12
V-2038 = L 19 H 25 V 14
V-2039 = L 17 H 25 V 12
V-2040 = L 13.5 H 20 V 10.5
V-2041 = L 11.5 H 20 V 8.5
B-138 = L 15 H 20 V 11
B-137 = L 15 H 15 V 11
B-136 = L 12 H 15 V 9

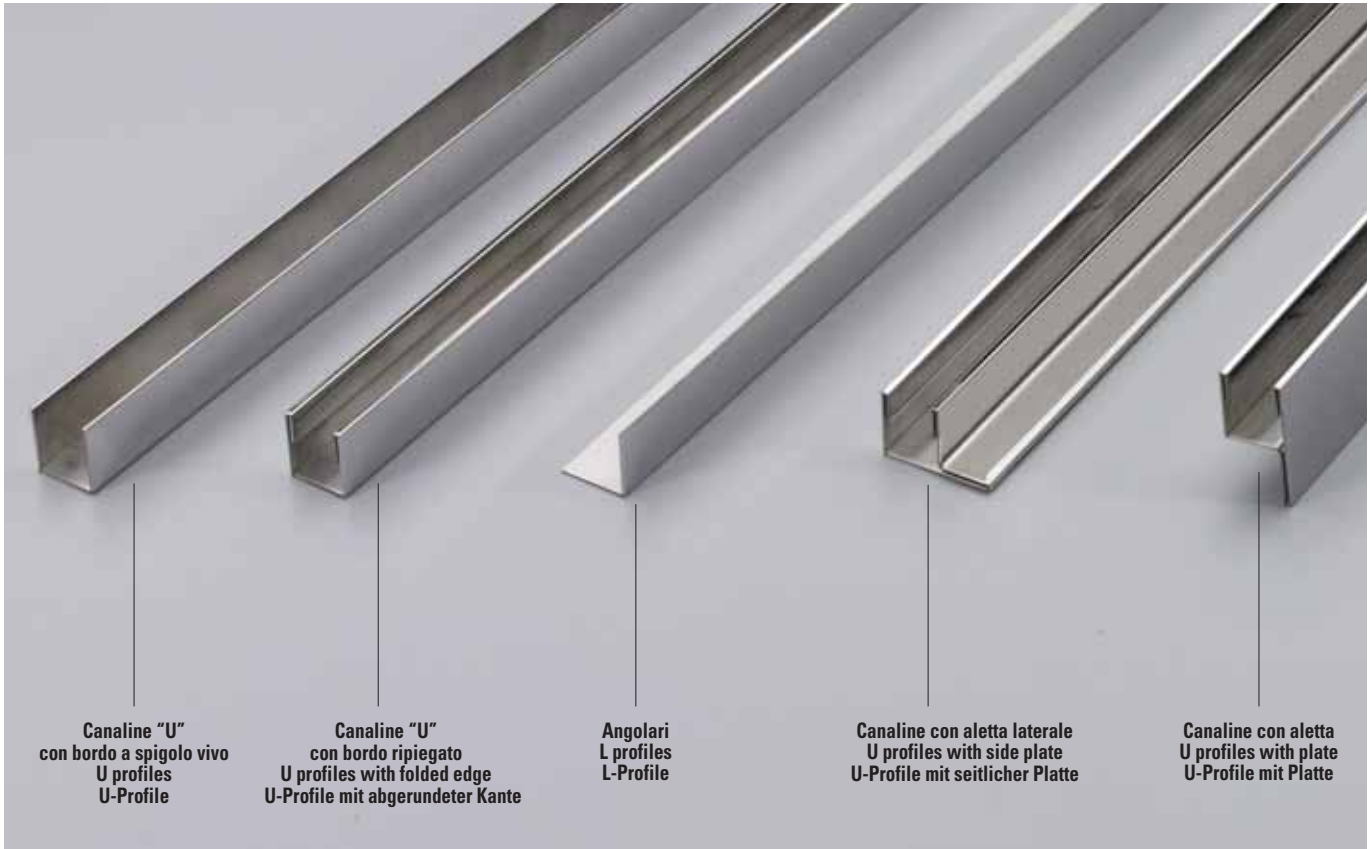

Canaline "U"
con bordo a spigolo vivo
U profiles
U-Profile

Canaline "U"
con bordo ripiegato
U profiles with folded edge
U-Profile mit abgerundeter Kante

Angolari
L profiles
L-Profile

Canaline con aletta laterale
U profiles with side plate
U-Profile mit seitlicher Platte

Canaline con aletta
U profiles with plate
U-Profile mit Platte

CANALINE "U" CON BORDO A SPIGOLO VIVO

U PROFILES
U-PROFILE

► 20

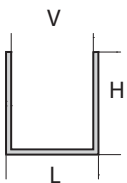

- Misure disponibili
- Available measures
- Verfügbare Maße
- V-2021 = L 18 H 20 V 16
- V-2020 = L 14.5 H 20 V 12.5
- V-2016 = L 12.5 H 20 V 10.5
- V-2017 = L 10.5 H 20 V 8.5
- V-2019 = L 8.5 H 20 V 6.5
- V-2018 = L 13 H 13 V 11

CANALINE "U" CON BORDO RIPIEGATO

U PROFILES
WITH FOLDED EDGE
U-PROFILE MIT
ABGERUNDETER KANTE

► 20

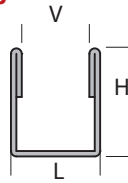

- Misure disponibili
- Available measures
- Verfügbare Maße
- V-2030 = L 16.5 H 20 V 12.5
- V-2016-R = L 14.5 H 20 V 10.5
- V-2017-R = L 12.5 H 20 V 8.5
- V-2029 = L 10.5 H 20 V 6.5

ANGOLARI

L PROFILES
L-PROFILE

► 21

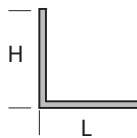

- Misure disponibili
- Available measures
- Verfügbare Maße
- V-2025 = L 30 H 30
- V-2024 = L 20 H 20
- V-2023 = L 15 H 15
- V-2022 = L 10 H 10

CANALINE CON ALETTA LATERALE

U PROFILES
WITH SIDE PLATE
U-PROFILE MIT
SEITLICHER PLATTE

► 21

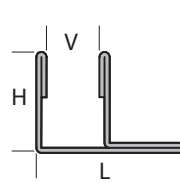

- Misure disponibili
- Available measures
- Verfügbare Maße
- V-2028 = L 31.5 H 20 V 12.5
- V-2027 = L 29.5 H 20 V 10.5
- V-2026 = L 27.5 H 20 V 8.5

CANALINE CON ALETTA

U PROFILES WITH PLATE
U-PROFILE MIT PLATTE

► 21

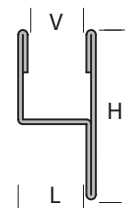

- Misure disponibili
- Available measures
- Verfügbare Maße
- V-2033 = L 16.5 H 36 V 12.5
- V-2032 = L 14.5 H 36 V 10.5
- V-2031 = L 12.5 H 35 V 8.5

P-065

PROFILI A SCATTO PER FISSI / CLIP-ON PROFILES FOR FIXED PANELS / KLIPSPROFILE FÜR FESTVERGLASUNGEN

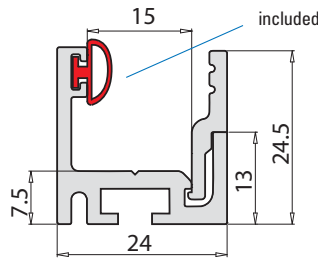
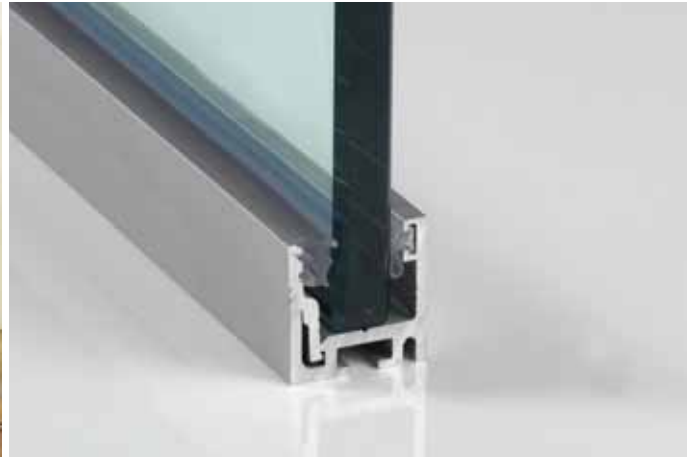

P-065

- Installazione facile e veloce con una guarnizione già premontata.
- Easy and quick installation of glass with one gasket premounted.
- Einfache und schnelle Glasmontage, da die Dichtung auf einer Seite vormontiert werden kann.

€ D.01

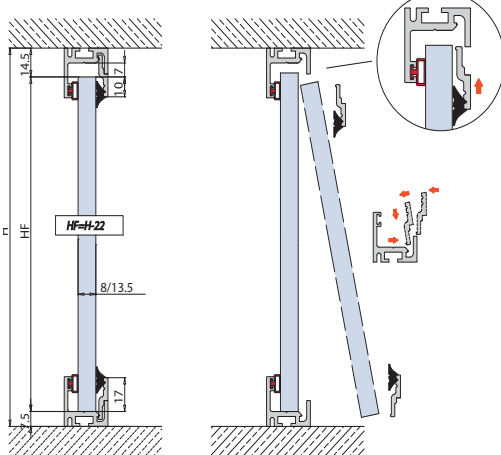

€ D.06

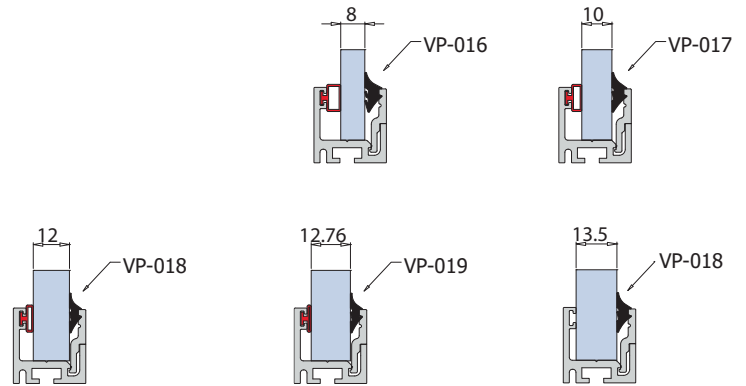

Combinazione P-065 con profilo P-059 / Combination P-065 with P-059 / Kombination P-065 mit P-059

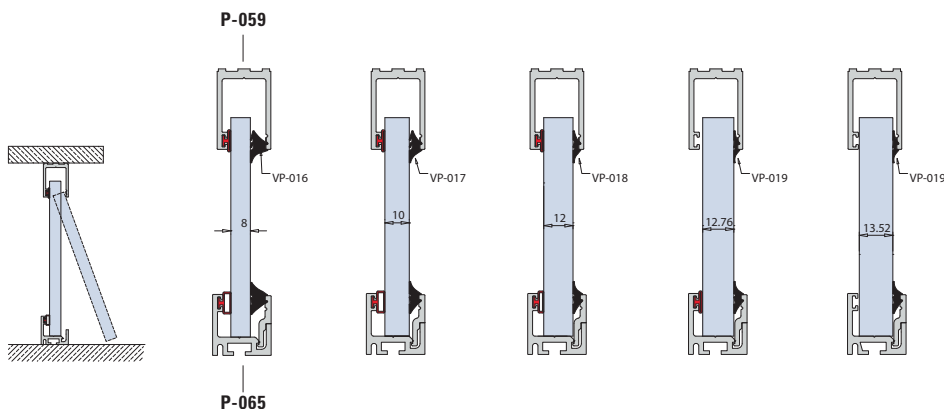
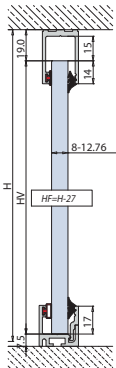

€ D.05

- P-065-TA-CF4**
- Confezione 4 pezzi tappi finali.
 - Package unit of 4 pieces endcaps.
 - Verpackungseinheit von 4 Stück Endkappen.



xme434 / xme435

P-058 / P-059

PROFILI A SCATTO PER FISSI / CLIP-ON PROFILES FOR FIXED PANELS / KLIPSPROFIFE FÜR FESTVERGLASUNGEN

PROFILI PER VETRI FISSI

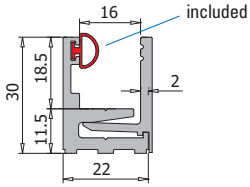
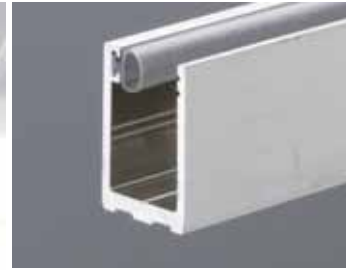

P-058

€ D.10

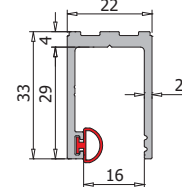

P-059

€ D.17

- Questo nuovo profilo migliora nettamente il montaggio perchè rispetto ai precedenti con due guarnizioni da montare, una è già premontata.
- Easy and quick installation of glass with one gasket premounted.
- Einfache und schnelle Glasmontage, da die Dichtung auf einer Seite vormontiert werden kann.

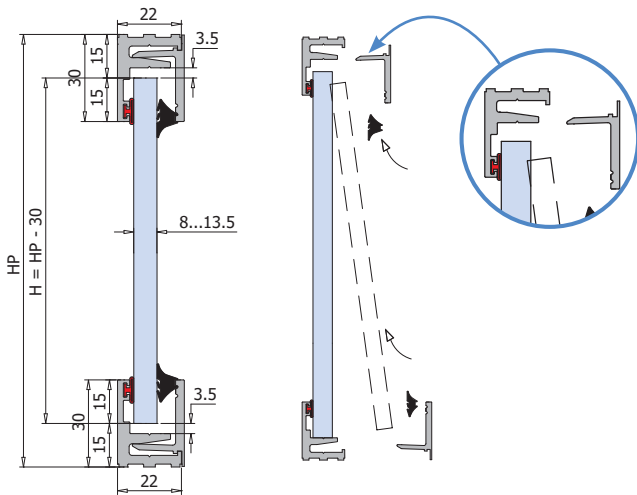

€ D.15

VP-016 VP-017 VP-018 VP-019 VP-019

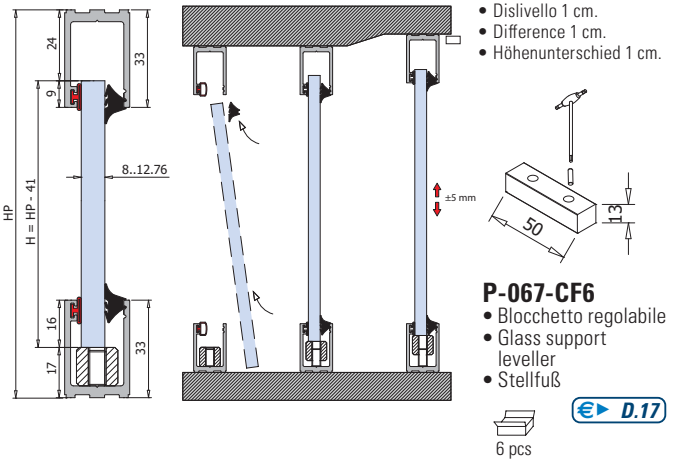
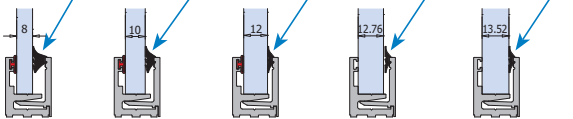

- Dislivello 1 cm.
- Difference 1 cm.
- Höhenunterschied 1 cm.

P-067-CF6
• Blocchetto regolabile
• Glass support leveller
• Stellfuß

€ D.17
6 pcs

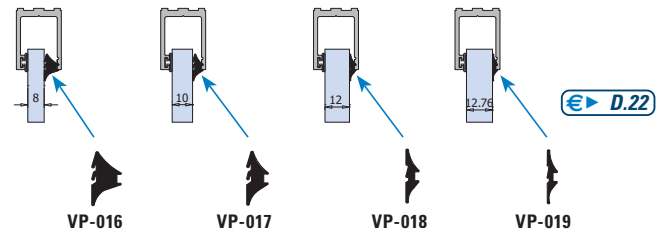

€ D.22

Combinazione P-058 con profilo P-059 / Combination P-058 with P-059 / Kombination P-058 mit P-059

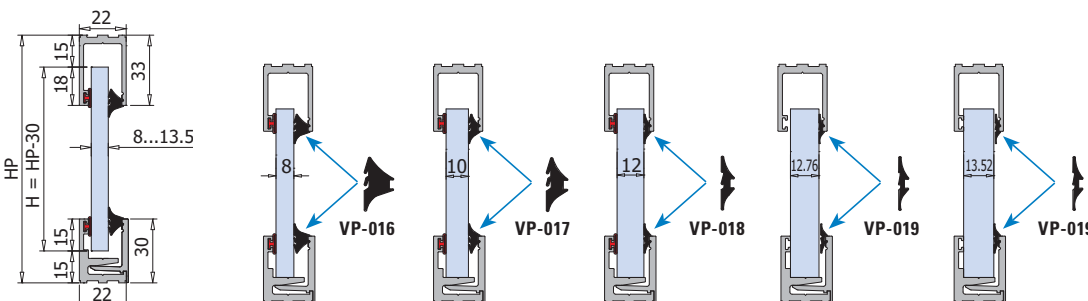

P-068-CF4 € D.14
P-069-CF4 € D.20

- Confezione 4 pezzi tappi finali.
- Package unit of 4 pieces endcaps.
- Verpackungseinheit von 4 Stück Endkappen.

€ D.20
4 pcs

xme333 / xme334

P-01 / P-02

PROFILI A SCATTO PER FISSI / CLIP-ON PROFILES FOR FIXED PANELS / KLIPSPROFILE FÜR FESTVERGLASUNGEN

PROFILI PER
VETRIFFISSI

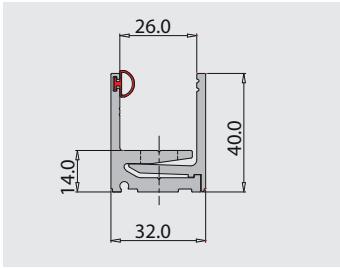

P-01

€ ▶ D.26

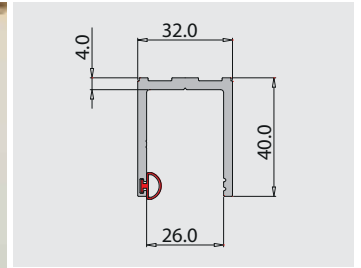

P-02

€ ▶ D.27

- Questo nuovo profilo migliora nettamente il montaggio perchè rispetto ai precedenti con due guarnizioni da montare, una è già premontata.
- Easy and quick installation of glass with one gasket premounted.
- Einfache und schnelle Glasmontage, da die Dichtung auf einer Seite vormontiert werden kann.

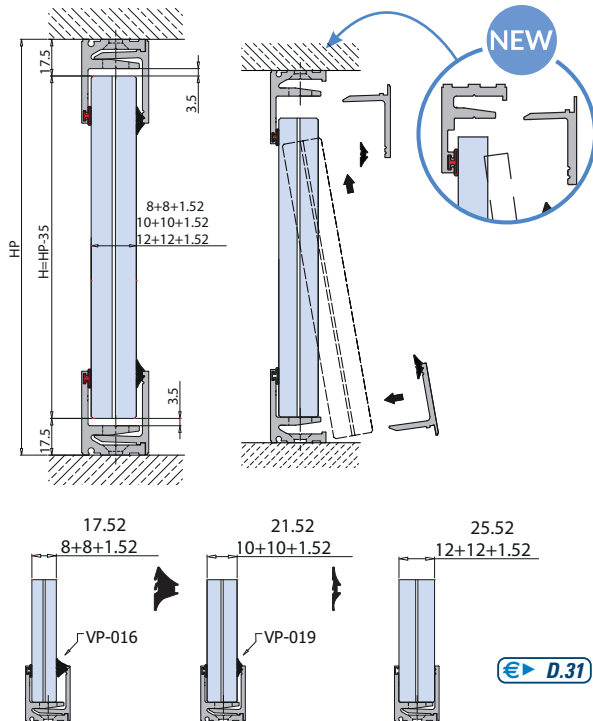

€ ▶ D.31

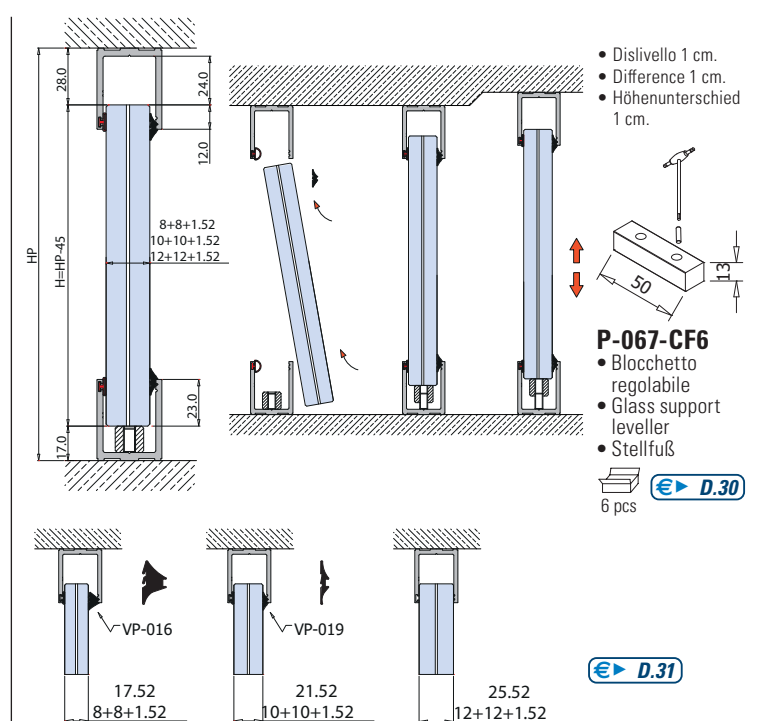

P-067-CF6

- Dislivello 1 cm.
- Difference 1 cm.
- Höhenunterschied 1 cm.

€ ▶ D.30
6 pcs

€ ▶ D.31

Combinazione P-01 con profilo P-02 / Combination P-01 with P-02 / Kombination P-01 mit P-02

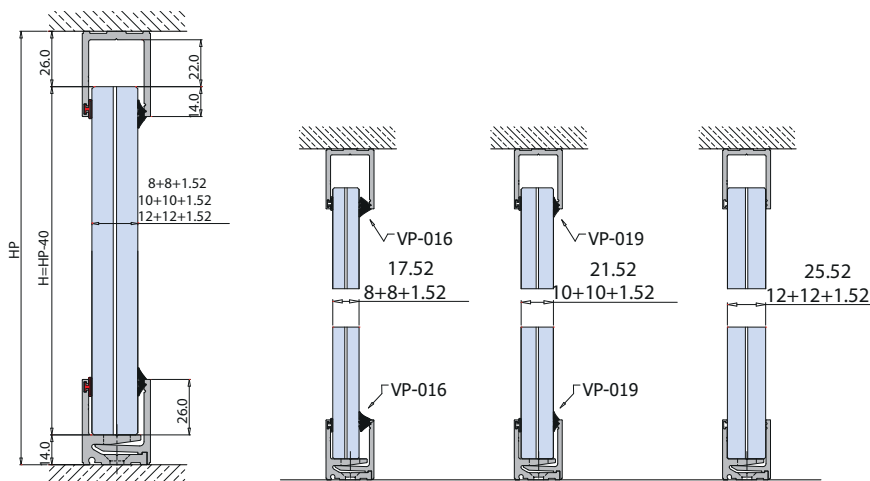

€ ▶ D.28

P-01/02-TA-CF4

- Confezione 4 pezzi tappi finali.
- Package unit of 4 pieces endcaps.
- Verpackungseinheit von 4 Stück Endkappen.



4 pcs

P-050 / P-055

PROFILI A SCATTO PER FISSI / CLIP-ON PROFILES FOR FIXED PANELS / KLIPSPROFILE FÜR FESTVERGLASUNGEN

PROFILI PER VETRI FISSI

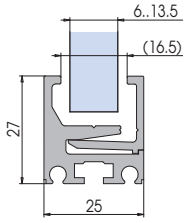
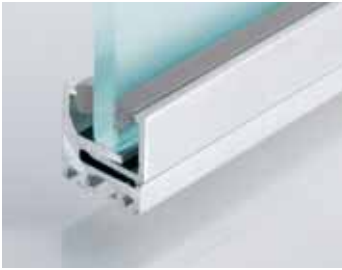

P-050

€ D.07

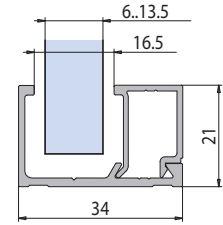

P-055

€ D.23

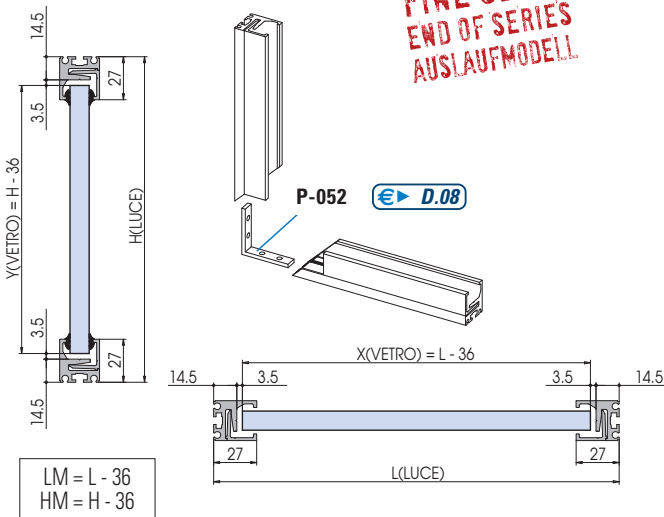

P-052

€ D.08

P-056

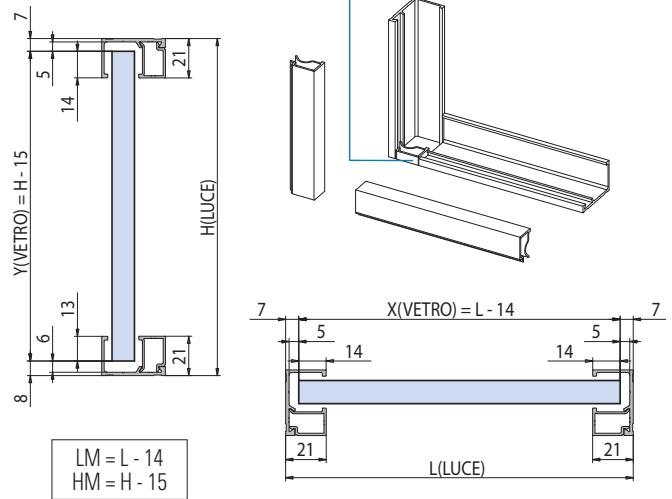

LM = L - 14
HM = H - 15

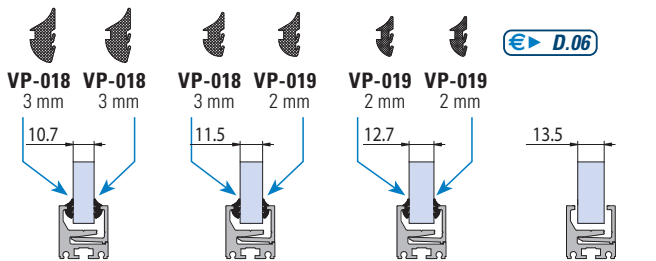
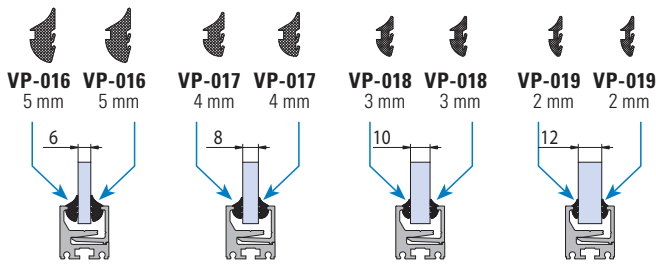

P-051 € D.09

- Pezzo tappo chiusura.
- Piece endcap.
- Stück Endkappe.

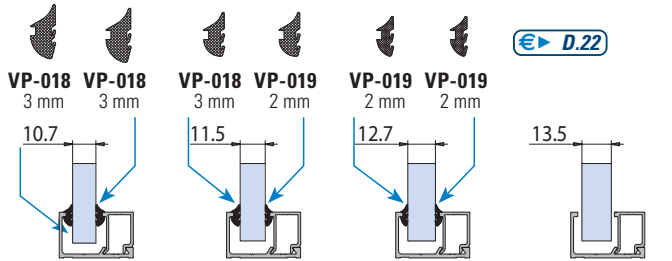
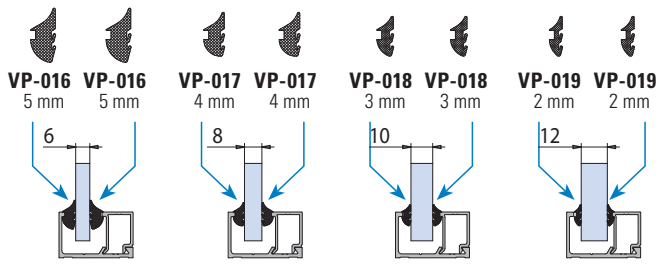

P-057 € D.25

- Pezzo tappo chiusura.
- Piece endcap.
- Stück Endkappe

xla221 / xla221a / xla223 / xla224

CANALINE "U" IN ALLUMINIO

U PROFILES IN ALUMINIUM / U-PROFILE

PROFIL PER
VETRIFFISSI



V-2036	V-2037	V-2038	V-2039	V-2040	V-2041
<p>V-2036</p> <ul style="list-style-type: none"> • Canalina con bordi arrotondati. • "U" channel. • U-Profil Aluminium. L = 3000 mm CR - IXE - AN <p>➤ D.32</p> <p>6 + 6 + 1,52 6 + 6 + 0,76 12</p>	<p>V-2037</p> <ul style="list-style-type: none"> • Canalina con bordi arrotondati. • "U" channel. • U-Profil Aluminium. L = 3000 mm CR - IXE - AN <p>➤ D.33</p> <p>5 + 5 + 1,52 5 + 5 + 0,76 10</p>	<p>V-2038</p> <ul style="list-style-type: none"> • Canalina con bordi arrotondati. • "U" channel. • U-Profil Aluminium. L = 3000 mm CR - IXE - AN <p>➤ D.34</p> <p>6 + 6 + 1,52 6 + 6 + 0,76 12</p>	<p>V-2039</p> <ul style="list-style-type: none"> • Canalina con bordi arrotondati. • "U" channel. • U-Profil Aluminium. L = 3000 mm CR - IXE - AN <p>➤ D.35</p> <p>5 + 5 + 1,52 5 + 5 + 0,76 10</p>	<p>V-2040</p> <ul style="list-style-type: none"> • Canalina con bordi arrotondati. • "U" channel. • U-Profil Aluminium. L = 3000 mm CR - IXE - AN <p>➤ D.36</p> <p>10</p>	<p>V-2041</p> <ul style="list-style-type: none"> • Canalina con bordi arrotondati. • "U" channel. • U-Profil Aluminium. L = 3000 mm CR - IXE - AN <p>➤ D.37</p> <p>8</p>
<p>V-2036 - T</p> <ul style="list-style-type: none"> • Tappo per profilo • Endcap • EndKappe <p>19</p>	<p>V-2037 - T</p> <ul style="list-style-type: none"> • Tappo per profilo • Endcap • EndKappe <p>17</p>	<p>V-2038 - T</p> <ul style="list-style-type: none"> • Tappo per profilo • Endcap • EndKappe <p>19</p>	<p>V-2039 - T</p> <ul style="list-style-type: none"> • Tappo per profilo • Endcap • EndKappe <p>17</p>	<p>V-2040 - T</p> <ul style="list-style-type: none"> • Tappo per profilo • Endcap • EndKappe <p>13,5</p>	<p>V-2041 - T</p> <ul style="list-style-type: none"> • Tappo per profilo • Endcap • EndKappe <p>11,5</p>

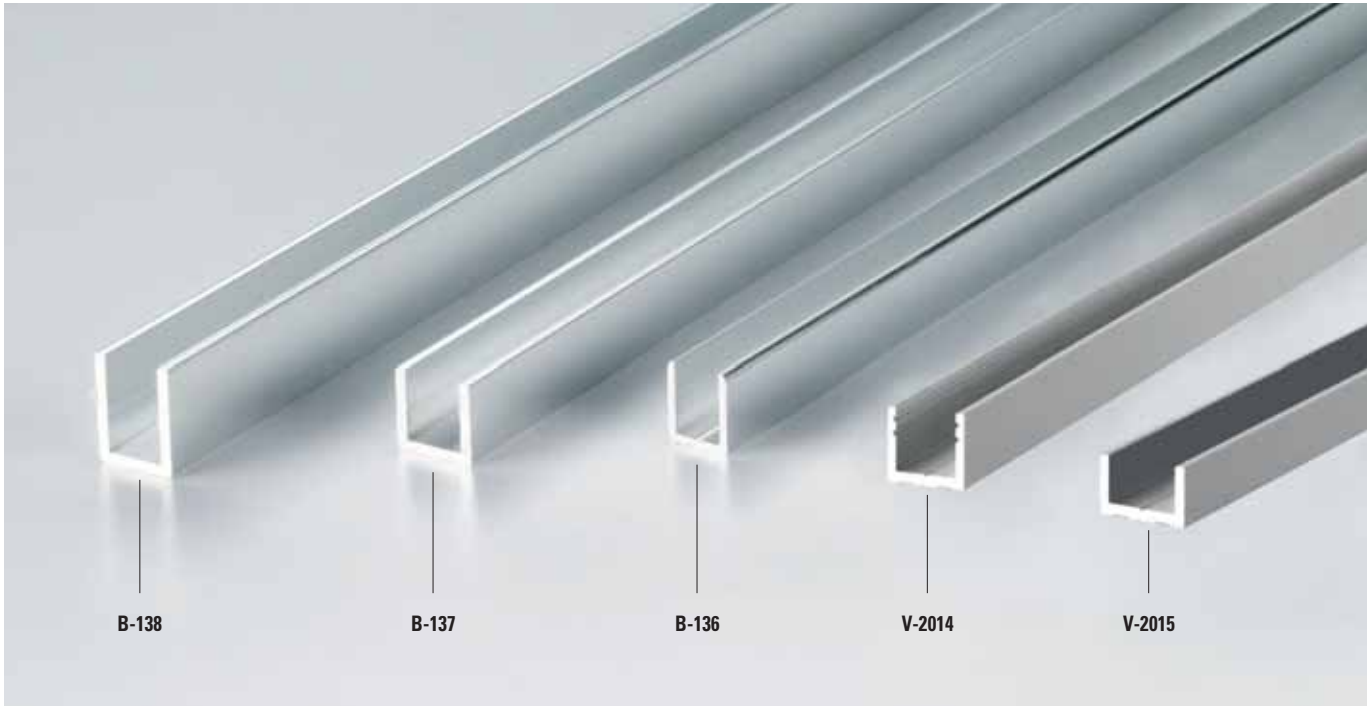

B-138 €▶ D.38

- Canalina spigoli vivi.
- Sharp corner "U" channel.
- U-Profil Aluminium.

L = 3000 mm
CR - AN

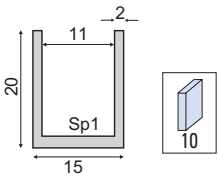

B-137 €▶ D.39

- Canalina spigoli vivi.
- Sharp corner "U" channel.
- U-Profil Aluminium.

L = 3000 mm
CR - AN

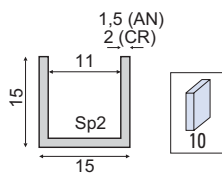

B-136 €▶ D.40

- Canalina con bordi arrotondati.
- "U" channel.
- "U"-Profil Aluminium.

L = 3000 mm
CR - NO

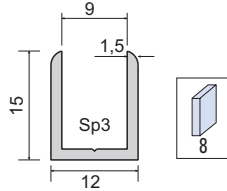

V-2014 €▶ D.41

- Canalina per vetro fisso, escluse guarnizioni
- U-channel for fixed panel, gaskets not included
- U-Profil für Seitenteil, Dichtungen nicht inkl

AN - IXE - NO

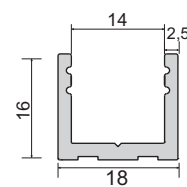

- Guarnizioni
- Gaskets
- Dichtungen

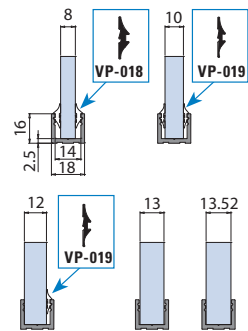

xla367b

V-2015 €▶ D.42

- Canalina per vetro fisso, comprese guarnizioni per vetro 10 mm
- U-channel for fixed panel, gaskets included for glass 10 mm
- U-Profil für Seitenteil, Dichtungen enthalten für Glasdicke 10 mm

AN - IXE

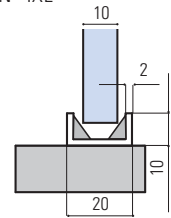

- Guarnizione nera inclusa
- Black gasket included
- Schwarze Dichtung enthalten



xla308

CR Cromo lucido Polished chrome Chrom glänzend	IXE Effetto inox Inox effect Inox effekt	AN Alluminio anodizzato Aluminium anodized Aluminium Silberfarbig	NO Nero opaco Matt black Schwarz matt
--	--	---	---

CANALINE "U" CON BORDO A SPIGOLO VIVO L = 2500 mm U PROFILES / U-PROFILE

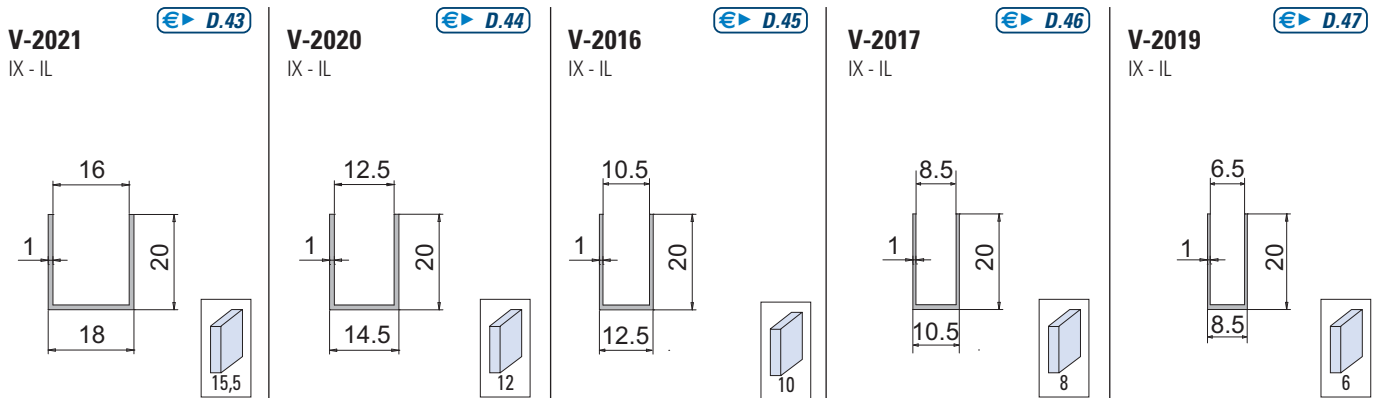

CANALINE "U" CON BORDO RIPIEGATO L = 2500 mm U PROFILES WITH FOLDED EDGE / U-PROFILE MIT ABGERUNDETER KANTE

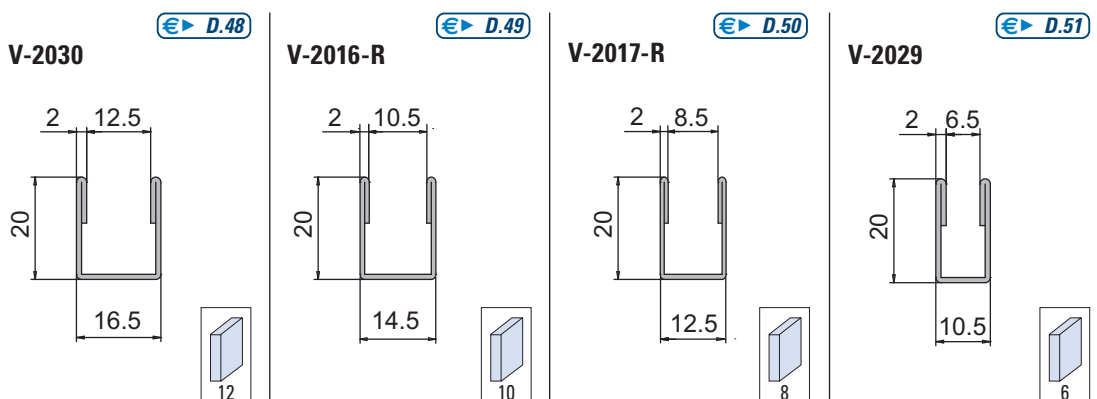

IX
Acciaio inox Aisi 304 satinato
Satin stainless steel AISI 304
Edelstahl AISI 304 matt

IL
Acciaio inox Aisi 304 lucido
Polished stainless steel AISI 304
Edelstahl AISI 304 poliert

ANGOLARI L = 2500 mm

L PROFILES / L-PROFILE

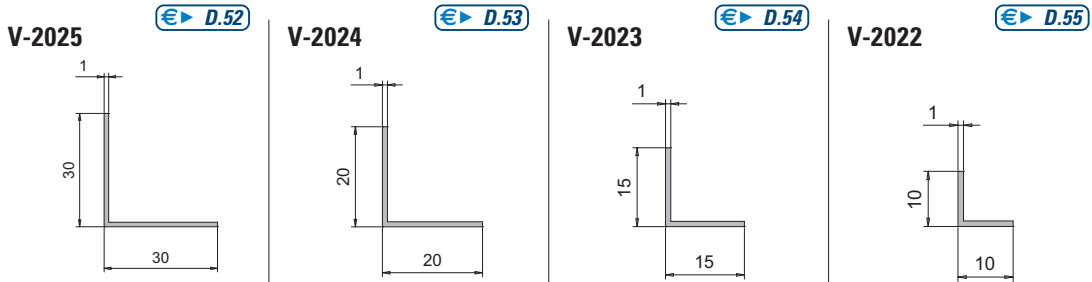

CANALINE CON ALETTA LATERALE L = 2500 mm

U PROFILES WITH SIDE PLATE / U-PROFILE MIT SEITLICHER PLATTE

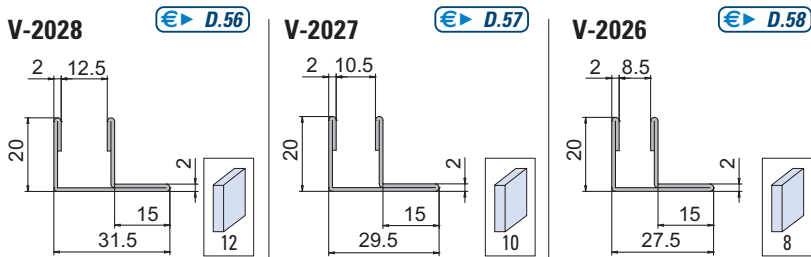

CANALINE CON ALETTA L = 2500 mm

U PROFILES WITH PLATE / U-PROFILE MIT PLATTE

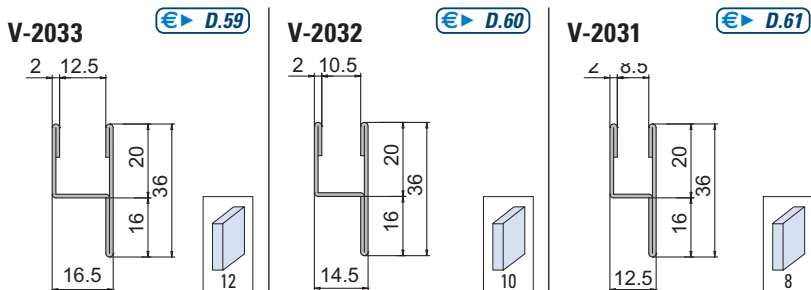

IX
Acciaio inox Aisi 304 satinato
Satin stainless steel AISI 304
Edelstahl AISI 304 matt

IL
Acciaio inox Aisi 304 lucido
Polished stainless steel AISI 304
Edelstahl AISI 304 poliert

PARETI DIVISORIE - TRATTA FISSA

PARTITION WALLS - FIXED PANELS
TRENNWÄNDE - FESTVERGLASUNGEN

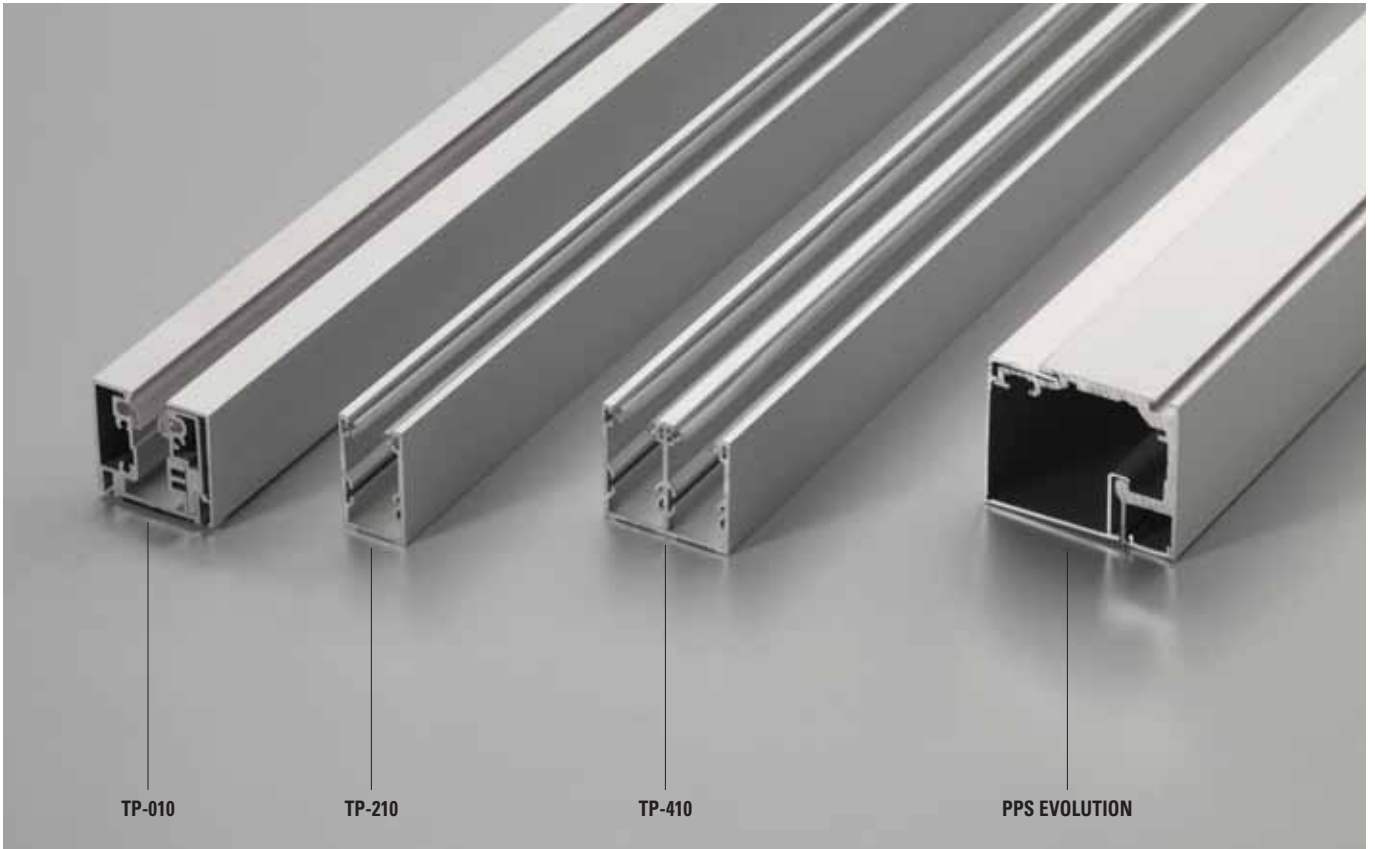

TP-010

TP-210

TP-410

PPS EVOLUTION

TP-010

▶ 26

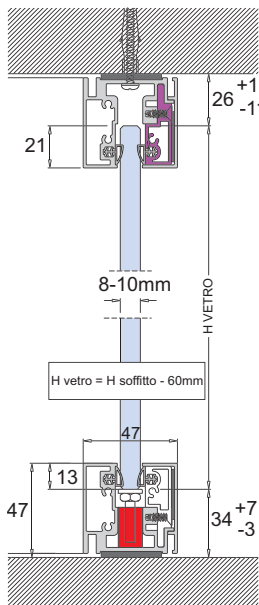

TP-210

▶ 24

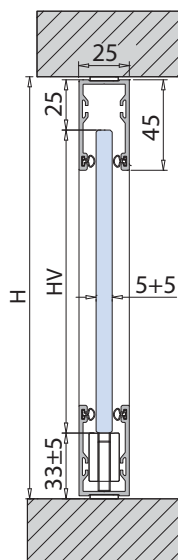

xme357

TP-410

▶ 25

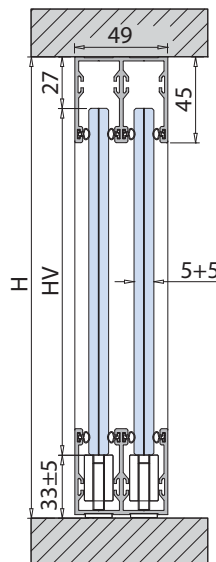

xme358

PPS EVOLUTION

▶ 27

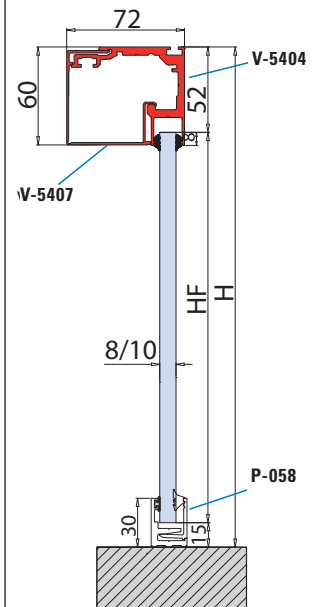

xme350



TP-210 EASY PARETE

ACCESSORI PER TRATTE VETRO FISSO / PARTITION WALL ACCESSORIES / TRENNWAND EINZELTEILE

PARETI DIVISORIE

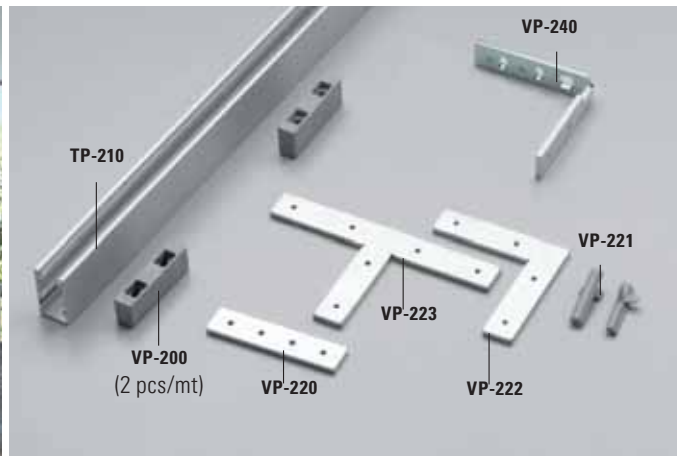

€ D.62 → € D.76

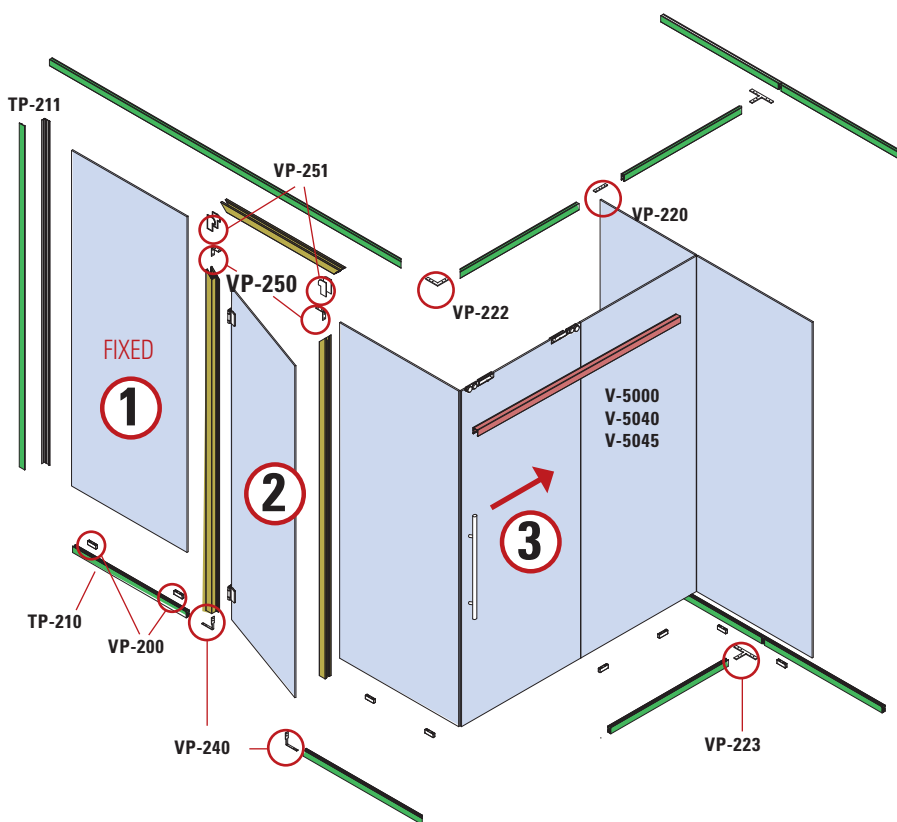

2 TP-201 ▶ 32
€ D.77

	ESEGUITE PROVE DI CARICO SULLA PORTA E SULLA PARETE
LABORATORIO FISICA TECNICA/ACUSTICA	PROVA: n° 0022/DC/ACU/15 RISULTATO: Rw (C;Ctr) = 36 (0;-2) dB

1 • Tratta fissa
• Partition wall
• Trennwand

3 • V-5000/V-5045 Scorrevole
• V-5000/V-5045 Sliding door
• V-5000/V-5045 Schiebetür

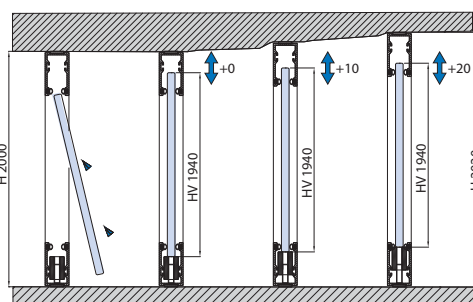
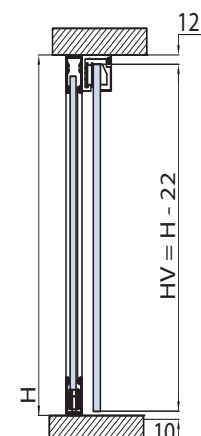
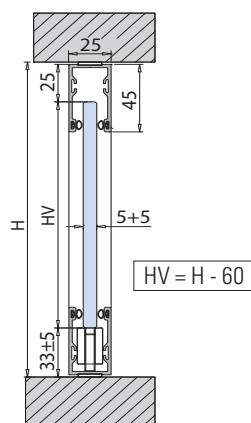

• Dislivello 20 mm
• Difference 20 mm
• Höhenunterschied 20 mm

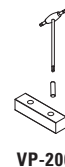

€ D.63

TP-211

• Profilo verticale partenza
• Vertical wall profil
• Vertikal Wandprofil

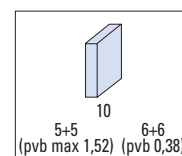

xme357 / xme367h
xme367i / xme367c / xme367l

TP-410 DUAL GLASS

ACCESSORI PER TRATTE VETRO FISSO / PARTITION WALL ACCESSORIES / TRENNWAND EINZELTEILE

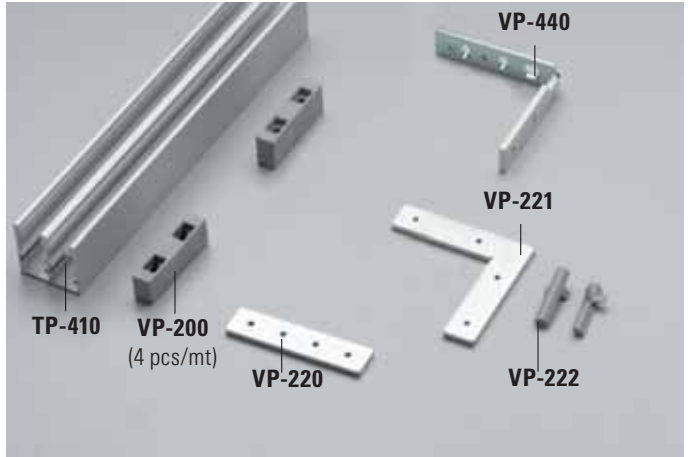

PARETI DIVISORIE

€▶ D.87 → €▶ D.99

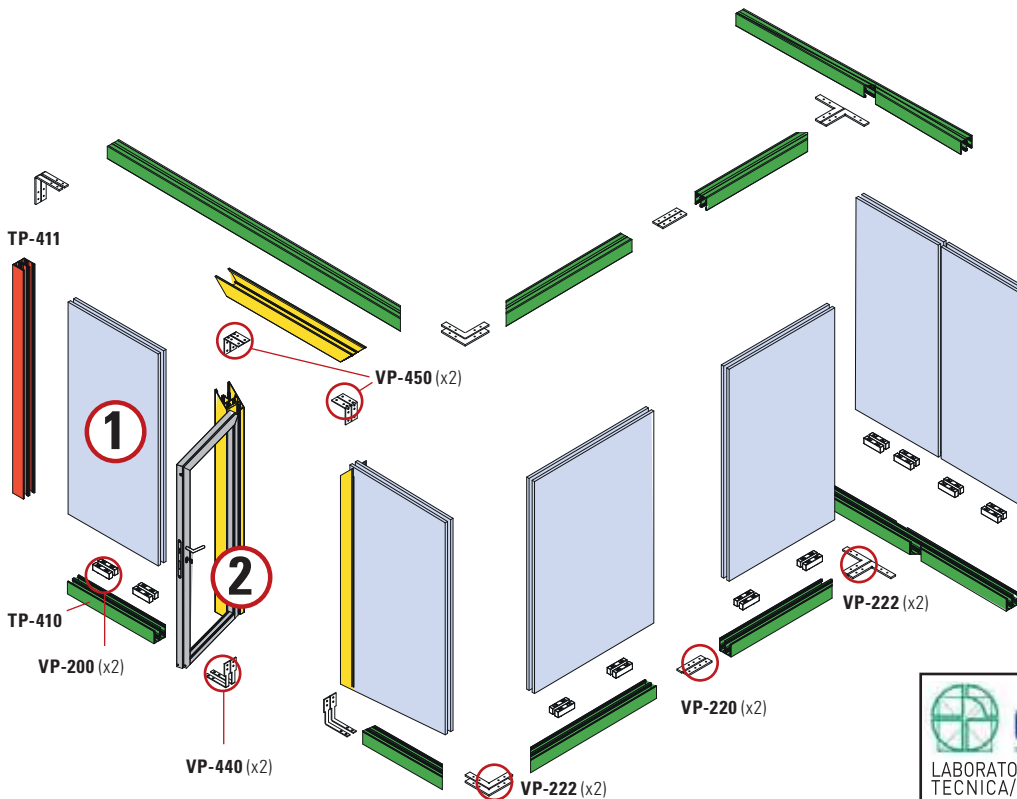

2 TP-401 ▶ 33
 €▶ D.100

<p>LABORATORIO FISICA TECNICA/ACUSTICA</p>	<p>PROVA: n° 0022/DC/ACU/15</p>
	<p>RISULTATO: Rw (C;Ctr) = 40 (0;-2) dB</p>

- 1**
- Tratta fissa
 - Partition wall
 - Trennwand

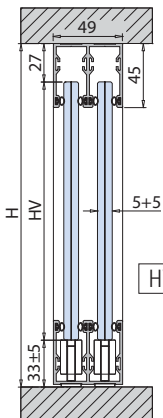

$HV = H - 60$

€▶ D.109
TP-411

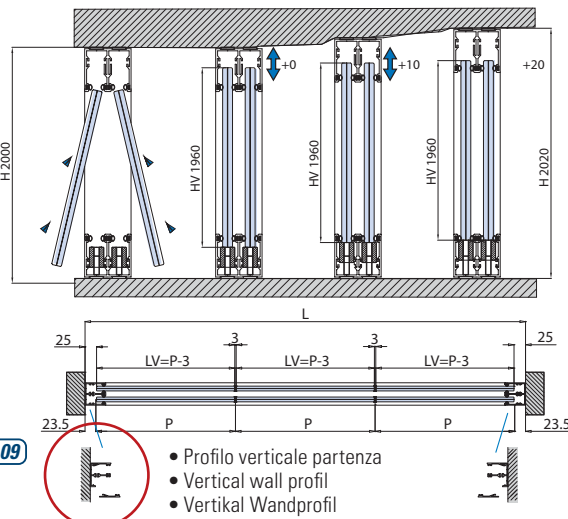

- Profilo verticale partenza
- Vertical wall profil
- Vertikal Wandprofil

- Dislivello 20 mm
- Difference 20 mm
- Höhenunterschied 20 mm

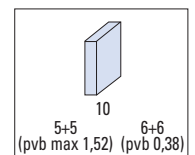
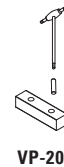

xme358 / xme367o / xme367n / xme367p

TP-010

ACCESSORI PER TRATTE VETRO FISSO / PARTITION WALL ACCESSORIES / TRENnwAND EINZELTEILE

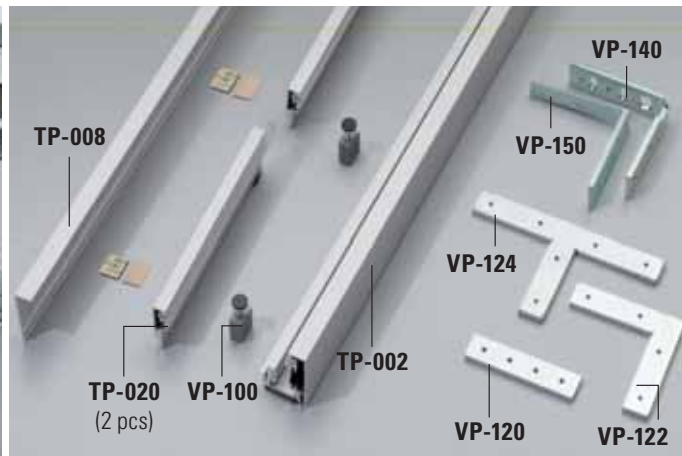

€▶D.116 → €▶D.134

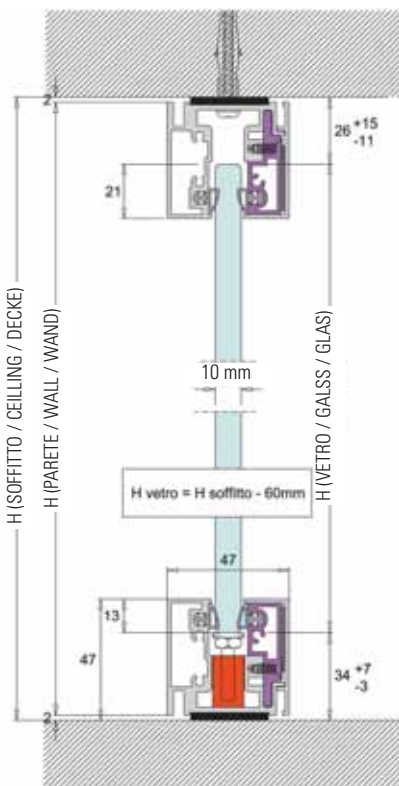

€▶D.117

TP-002

- Profilo parete
- Partition profile
- Rahmenprofil

€▶D.118

TP-020

- Profilo fermavetro
- Glass holding profile
- Glashalterungsprofile

€▶D.121

TP-008

- Carter
- Carter covering
- Abdeckungsprofil

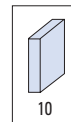
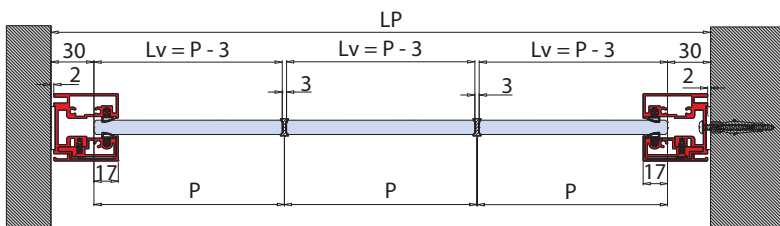

VP-130

- Staffa di collegamento verticale per profili parete
- Vertical connecting bracket for partition frames
- Vertikale Verbindungsstange für Wandprofile

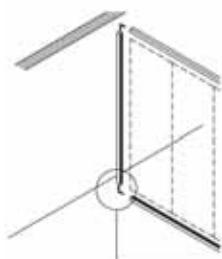

TP-002

- Profilo parete
- Partition profile
- Rahmenprofil

TP-002

- Profilo parete
- Partition profile
- Rahmenprofil



€▶D.126

PPS EVOLUTION MINI SOFT-CLOSE



PARETI DIVISORIE

- PPS è il nuovo innovativo programma di Profili e Accessori Metalglas che permette la realizzazione di Pareti divisorie in vetro integrate con porte scorrevoli o porte battenti. €D.152 → €D.175
- PPS is the new Metalglas Profiles and Accessories program, which allow the realisation of partition wall integrated with sliding or pivoting doors.
- PPS das neue Profil- und Zubehörprogramm von Metalglas. In diesem Programm sind die Trennwände mit den Dreh- und Schiebetüren in einem einzigen System zusammengefasst.

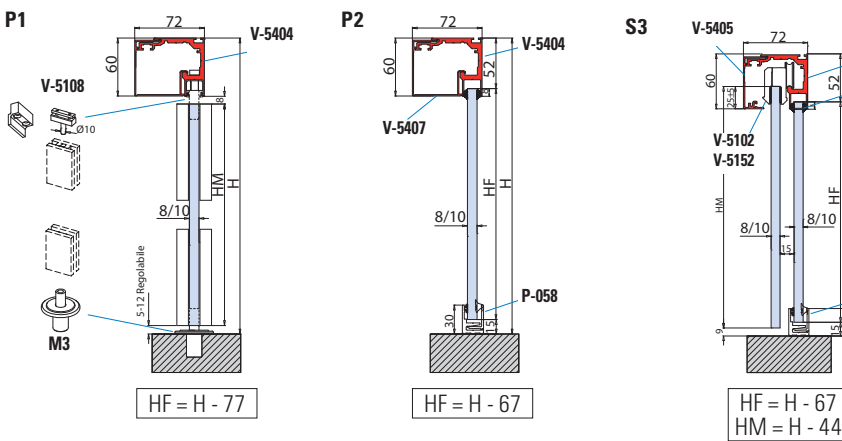
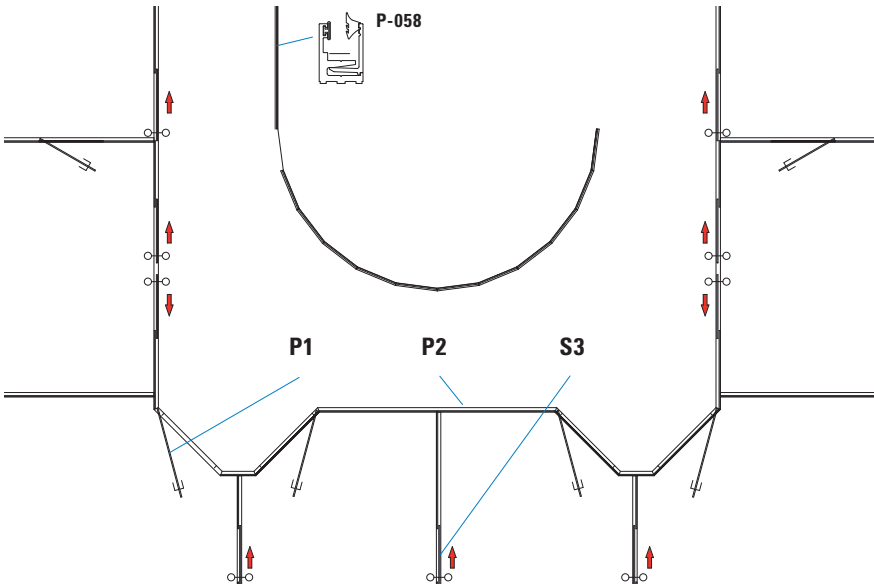

- P-058 (▶ 15)**
- Profili a scatto per fissi
 - Aluminium Profiles for fixed panels
 - Rahmensysteme aus Aluminium für Festverglasungen

xme350

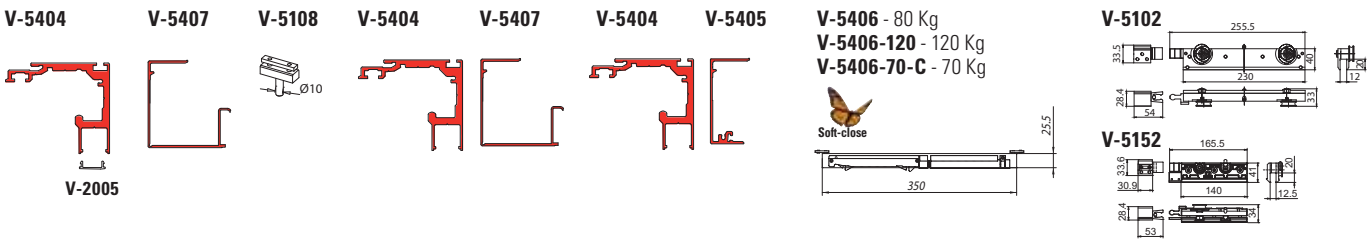

PROFILI IN POLICARBONATO BIADESIVI POLYCARBONATE PROFILE WITH ADHESIVE / POLYCARBONATPROFILE SELBSTKLEBEND

PARETI
DIVISORIE



VP-21 €▶D.181

- Profilo in policarbonato ad H per giunzione vetro 2 vie in linea con biadesivo 3M su ambo i lati
- H polycarbonate transparent profile with adhesive fixing for glass 10 mm
- H Polycarbonatprofil selbstklebend für Glas 10 mm

VP-22 €▶D.182

- Profilo in policarbonato ad H per giunzione vetro 2 vie in linea con biadesivo 3M su ambo i lati. Profili in barre da 3 metri per spessore vetro 12 mm. e 5+5+1,52
- H polycarbonate transparent profile with adhesive fixing for glass 12 and 5+5+1,52 mm. Profile in bars of 3 mt
- H Polycarbonatprofil selbstklebend für Glas 12 und 5+5+1,52 mm

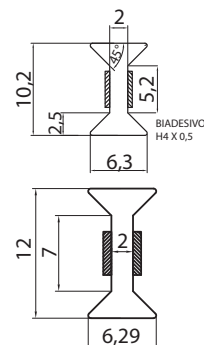

VP-23 €▶D.183

- Profilo in policarbonato per giunzione vetro 2 vie a 90° con biadesivo 3M sui lati. Profili in barre da 3 metri per spessore vetro 10/12 mm. e 5+5+1,52
- 2 way joints polycarbonate transparent profile with adhesive fixing for glass 10/12 mm. and 5+5+1,52 mm.
- 2-Wege Polycarbonatprofil selbstklebend für Glas 10/12 mm und 5+5+1,52 mm.

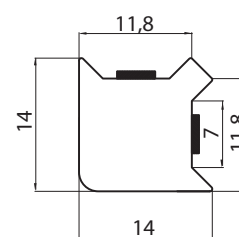

VP-24 €▶D.184

- Profilo in policarbonato per giunzione vetro 3 vie con biadesivo 3M sui lati. Profili in barre da 3 metri per spessore vetro 10/12 mm. e 5+5+1,52
- 3 way joints polycarbonate transparent profile with adhesive fixing for glass 10/12 mm. and 5+5+1,52 mm.
- 3-Wege Polycarbonatprofil selbstklebend für Glas 10/12 mm und 5+5+1,52 mm.

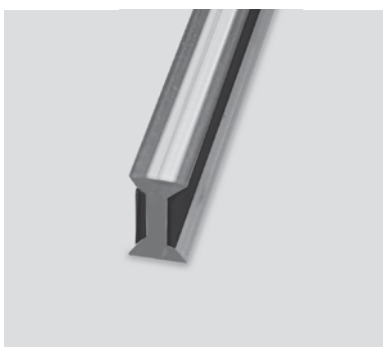
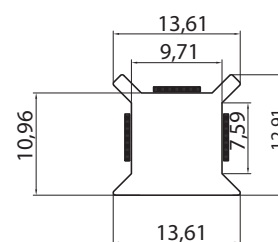

VP-40 €▶D.176

- Profilo in policarbonato L = 3000 mm per spessore vetro 8 mm.
- Polycarbonate transparent profile L = 3000 mm for glass 8 mm.
- Transparent Profil in Polycarbonat L = 3000 mm für Glas 8 mm.

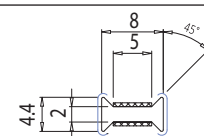

VP-41 €▶D.177

- Profilo in policarbonato L = 3000 mm per spessore vetro 10 mm.
- Polycarbonate transparent profile L = 3000 mm for glass 10 mm.
- Transparent Profil in Polycarbonat L = 3000 mm für Glas 10 mm.

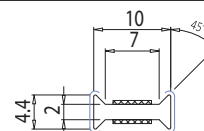

VP-42 €▶D.178

- Profilo in policarbonato L = 3000 mm per spessore vetro mm 5+5+1,52 pvb.
- Polycarbonate transparent profile L = 3000 mm for glass mm 5+5+1,52 pvb.
- Transparent Profil in Polycarbonat L = 3000 mm für Glas mm 5+5+1,52 pvb.

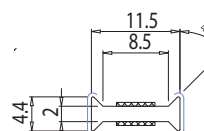

VP-43 €▶D.179

- Profilo in policarbonato L = 3000 mm per spessore vetro 12 mm.
- Polycarbonate transparent profile L = 3000 mm for glass 12 mm.
- Transparent Profil in Polycarbonat L = 3000 mm für Glas 12 mm.

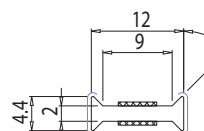

VP-44 €▶D.180

- Profilo in policarbonato L = 3000 mm per spessore vetro mm 6+6+1,52 pvb.
- Polycarbonate transparent profile L = 3000 mm for glass mm 6+6+1,52 pvb.
- Transparent Profil in Polycarbonat L = 3000 mm für Glas mm 6+6+1,52 pvb.

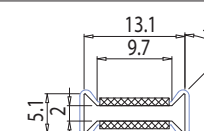



5 mt

WRU-M 80/50 MT5 [€▶D.187](#)

- Guarnizione neutra per vetro 8 mm, fissaggio adesivo.
- Neutral gasket for glass 8 mm, with adhesive fixing.
- Dichtungsprofil für 8 mm Glas, selbstklebend

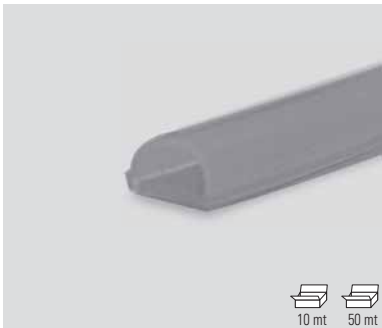
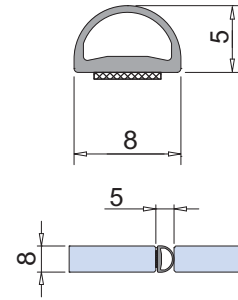

10 mt 50 mt

WRU-S60/40R [€▶D.186](#)

- Guarnizione neutra per vetro 8 mm. con fissaggio adesivo
- Neutral gasket for glass 8 mm. with adhesive fixing
- Dichtungsprofil für 8 mm Glaskante selbstklebend.

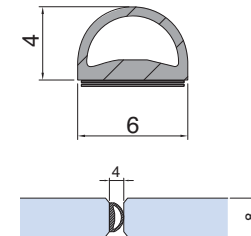

10 mt 100 mt

WRU-S100/60Z [€▶D.185](#)

- Guarnizione neutra per vetro 10-12 mm. con fissaggio adesivo
- Neutral gasket for glass 10-12 mm. with adhesive fixing
- Dichtungsprofil für 10/12 mm Glaskante selbstklebend.

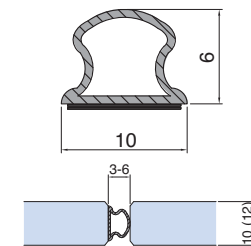

STIPITI SU VETRO

ALUMINIUM FRAMES WITH FIXED SIDE PANELS
ALUZARGEN MIT SEITENTEILEN



TP-201

► 32

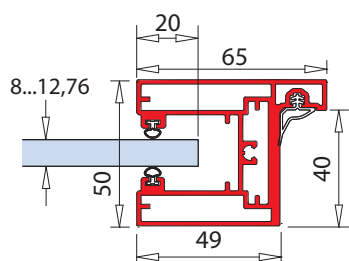

xme367b



TP-401

► 33

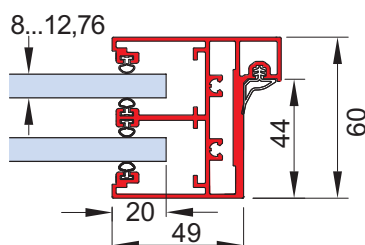

xme367a / xme369



P-085-V

► 38

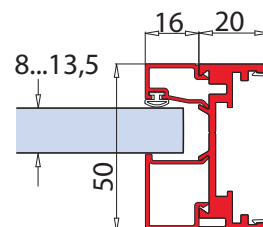

xme373d



P-080-V

▶ 37

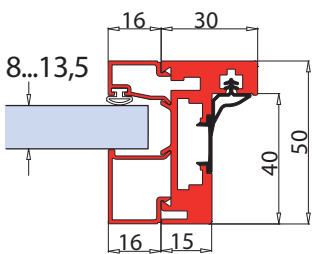

xme373b



TP-110

▶ 34

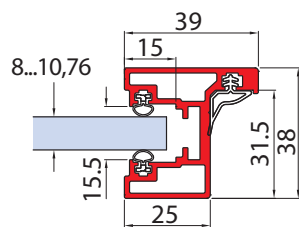

xme557b



TP-100

▶ 35

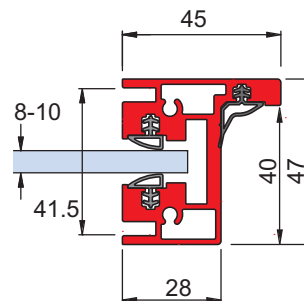

TP-100



P-030-V

▶ 36

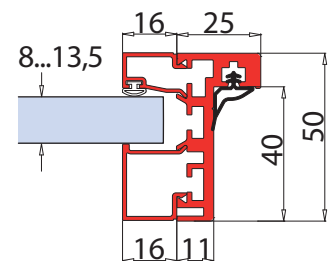

xme373g

31

TP-201

STIPITE PORTA BATTENTE / DOOR FRAME FOR HINGED DOOR / ALUZARGE



STIPITI SU VETRO

TP-201 D.77

- Stipite porta battente
- Door frame for hinged door
- Aluzarge

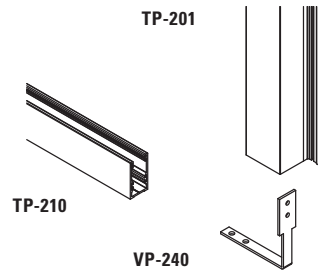
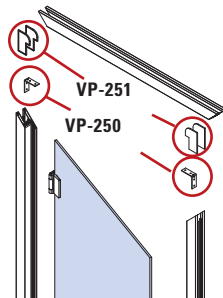
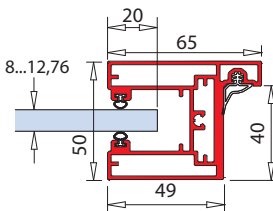

- Porta battente vetro con cerniere
- Frameless glass door with hinges
- Glastür mit Bänder

- Senza regolazione
- Without adjustment
- Ohne Verstellung

- Con regolazione
- With adjustment
- Mit Verstellung

- Fresatura per regolazione a cura del cliente
- Milling for adjustment by the customer
- Fräsung für Verstellung bauseits

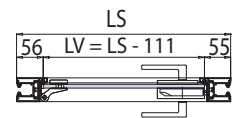
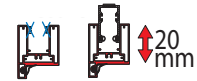
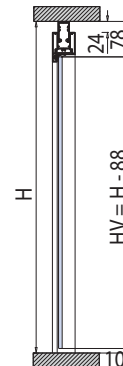
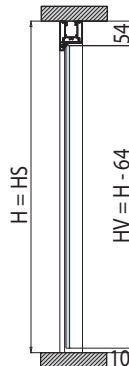
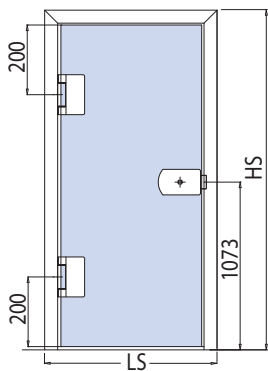

PO-100 / PO-200 D.269

- Porta battente intelaiata
- Framed glass door
- Flügelrahmen

- Senza regolazione
- Without adjustment
- Ohne Verstellung

- Con regolazione
- With adjustment
- Mit Verstellung

- Fresatura per regolazione a cura del cliente
- Milling for adjustment by the customer
- Fräsung für Verstellung bauseits

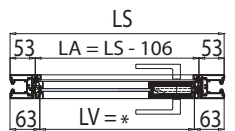
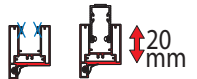
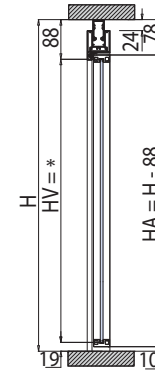
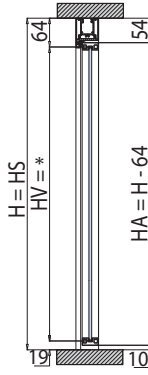
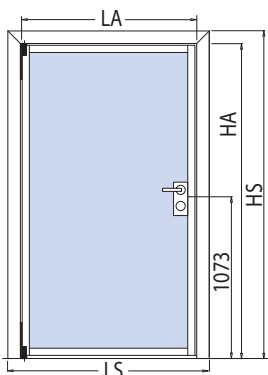

LA = LS - 106

HA = H - 64

HA = H - 88

* PO-100: (▶ 58)

HV = HA - 19

LV = LA - 19



* PO-200: (▶ 56)

HV = HA - 27

LV = LA - 15



TP-401

STIPITE PORTA BATTENTE / DOOR FRAME FOR HINGED DOOR / ALUZARGE

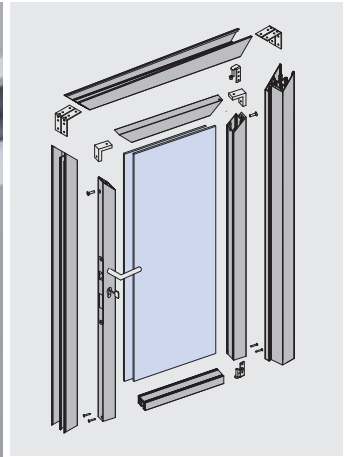

STIPITI SU VETRO

TP-401 €>D.100

- Stipite porta battente
- Door frame for hinged door
- Aluzarge

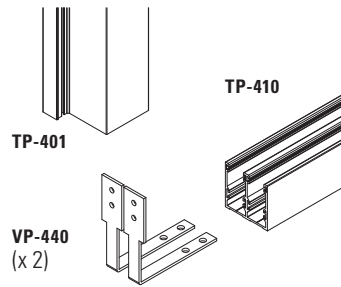
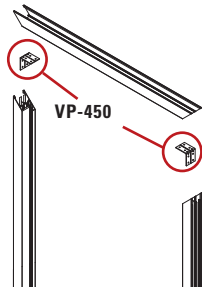
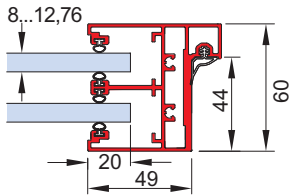

TP-405 €>D.107

- Porta battente intelaiata
- Framed glass door
- Flügelrahmen

- Senza regolazione
- Without adjustment
- Ohne Verstellung
- Con regolazione
- With adjustment
- Mit Verstellung

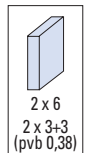
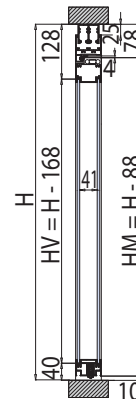
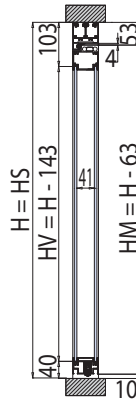
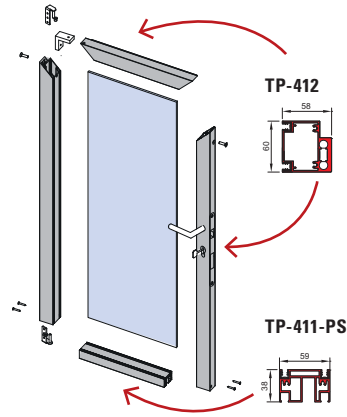
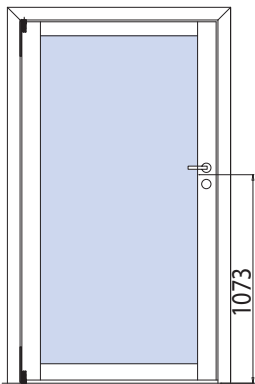

TP-411-PS €>D.109

- Fresatura per regolazione a cura del cliente
- Milling for adjustment by the customer
- Fräsung für Verstellung bauseits

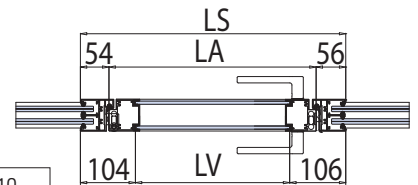
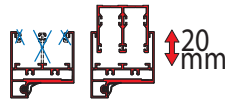
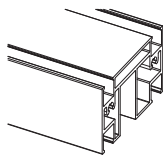
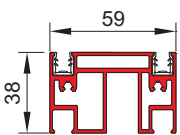

- LA = LS - 110
- LV = LS - 210
- TP - 411 = LA - 116

TP-412 €>D.108

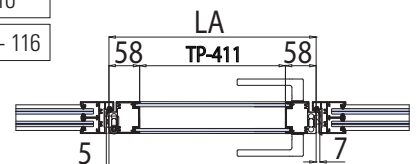
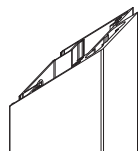
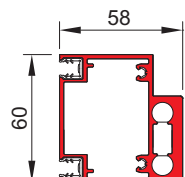

TP-110

€D.144 → €D.151

STIPITI SU
VETRO

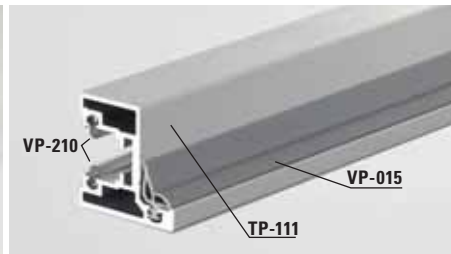

TP-110

TP-111-FIX

P-115-CF2

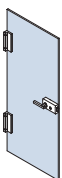
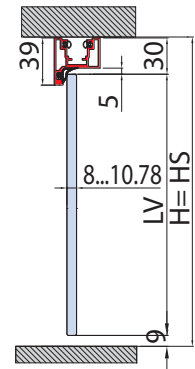
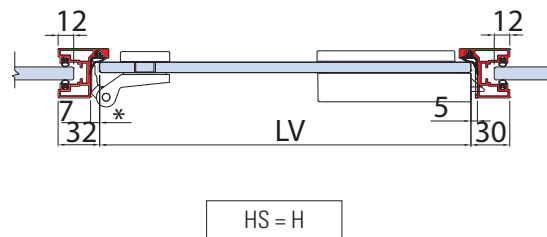
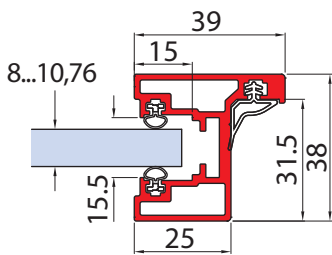

V-409 V-509 V-709 V-809 V-909 V-729

$$LV = LS - (32^* + 30)$$

$$HV = H - 39$$

V-701 V-704

$$LV = LS - (33^* + 30)$$

$$HV = H - 39$$

ESEMPIO MONTAGGIO / ASSEMBLY / MONTAGE

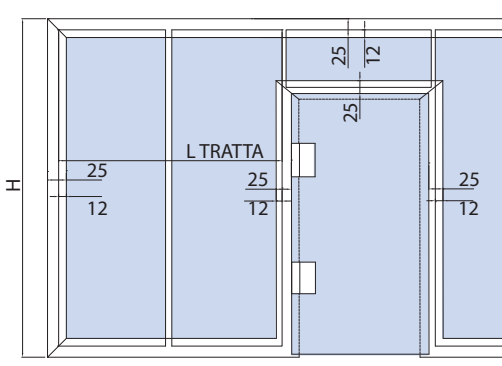

P-065 ▶ 14

P-059 ▶ 15

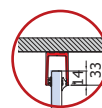
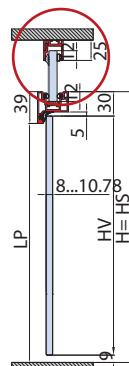

P-058 ▶ 15

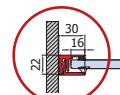

P-065 ▶ 14

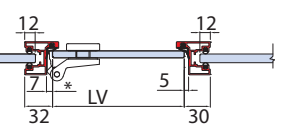
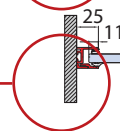

xme557b

TP-100

€▶D.135 → €▶D.143

STIPITE ALLUMINIO PER PARETE DIVISORIA / PARTITION WALL ALUMINIUM FRAME / ALU-ZARGEN FÜR TRENNWAND



STIPITI SU VETRO

- Stipite porta battente
- Door frame for hinged door
- Aluzarge

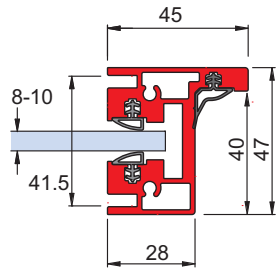

- Guarnizioni vetro
- Glass gasket
- Dichtung
- Profilo stipite
- Door frame profile
- Türzargenprofil
- Staffa collegamento stipiti
- Door frame connecting bracket
- Stange zum Verbinden der Türzarge
- Guarnizione di battuta porta
- Glass gasket
- Dichtung

- TP-100**
- Stipite
 - Door frame profile
 - Türzarge
- TP-002**
- Profilo parete
 - Partition profile
 - Rahmenprofil

- Porta battente vetro con cerniere
- Frameless glass door with hinges
- Glastür mit Bänder

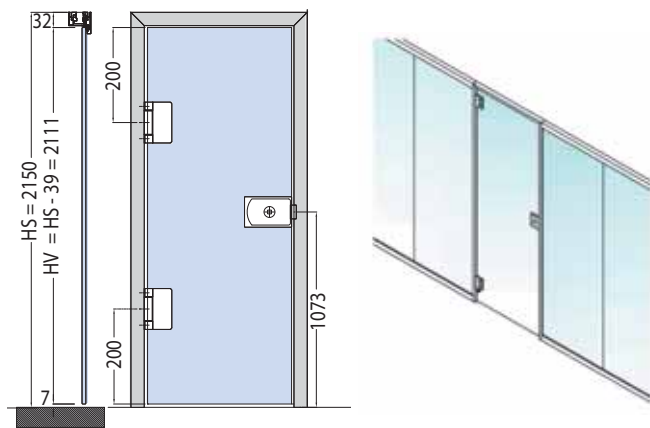

PO-100 / PO-200

- Porta battente intelaiata in alluminio
- Framed glass door
- Drehtür mit Flügelrahmen aus Aluminium

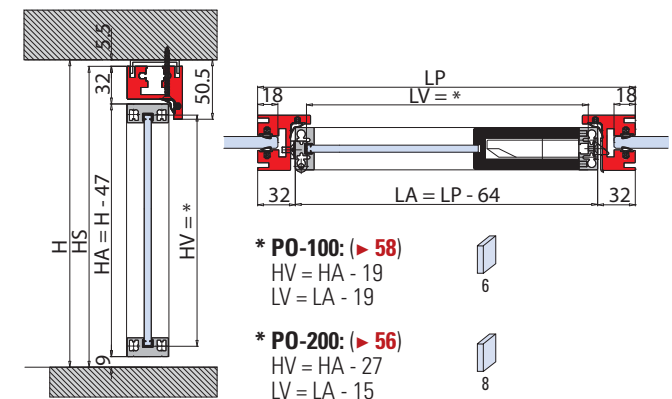
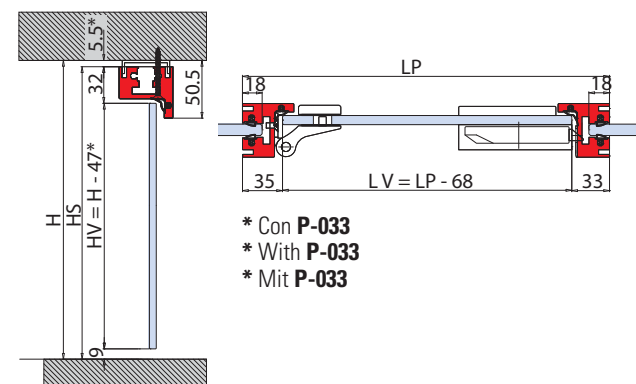
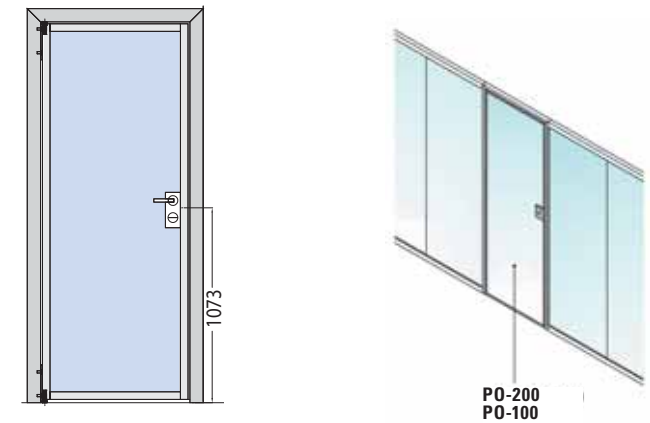

P-030-V

€D.188 → €D.199

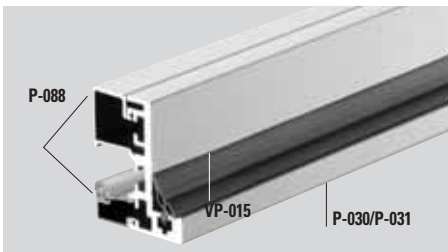

P-088 con/with/mit P-030 or P-031

P-012-CF4

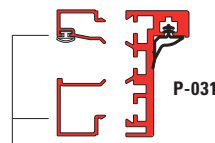
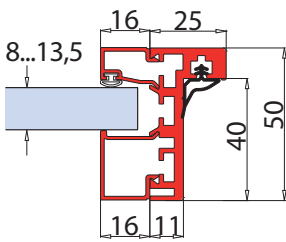

P-088

- Coppia profili L=3000 mm per fissaggio vetro fisso
- Pair clipping profiles L=3000 mm for fixed panels
- Paar Klipsprofile L=3000 mm für Fixierung des Festteils

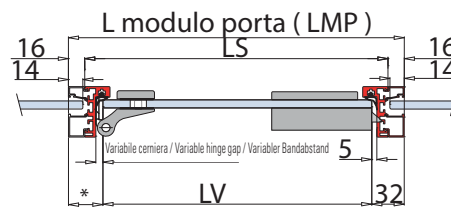

$$\begin{matrix} HS = H \\ LS = LPM - 32 \end{matrix}$$

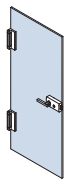
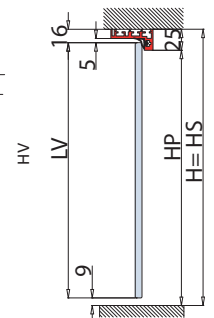

V-409 V-509 V-709 V-809 V-909 V-729

$$\begin{matrix} LV = LMP - (34^* + 32) \\ HV = H - 25 \end{matrix}$$

V-701 V-704 V-807

$$\begin{matrix} LV = LMP - (35^* + 32) \\ HV = H - 25 \end{matrix}$$

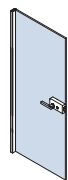

P-08

$$\begin{matrix} LV = LMP - (36^* + 32) \\ HV = H - 25 \end{matrix}$$

P-09

$$\begin{matrix} LV = LMP - (32^* + 32) \\ HV = H - 25 \end{matrix}$$



P0-200 P0-100

$$\begin{matrix} LA = LMP - (32^* + 32) \\ HA = H - 25 \end{matrix}$$

ESEMPIO MONTAGGIO / ASSEMBLY / MONTAGE

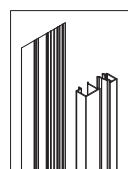
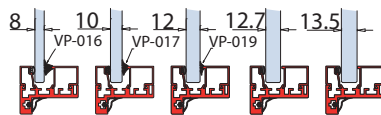
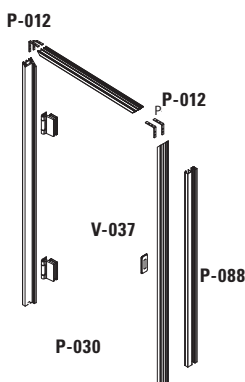

P-088

- Profili fermavetro
- Clipping profiles for fixed panel
- Klipsprofile für Festverglasung

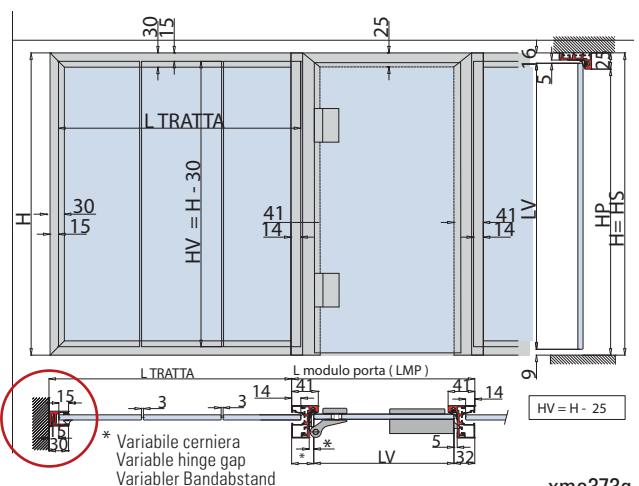

xme373g

P-080-V

€▶D.225 → €▶D.239

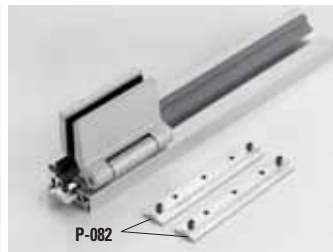
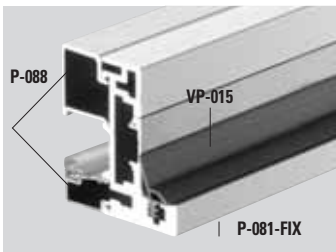

P-082-CF2

- Per fissaggio cerniere
- For hinges installation
- Befestigungsplatte für Bänder

P-088 con/with/mit P-080 or P-081 P-083 - CF2

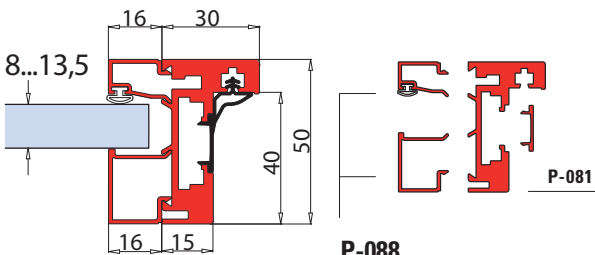

P-088

- Coppia profili L=3000 mm per fissaggio vetro fisso
- Pair clipping profiles L=3000 mm for fixed panels
- Paar klipsprofile L=3000 mm für Fixierung des Festteils

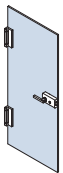
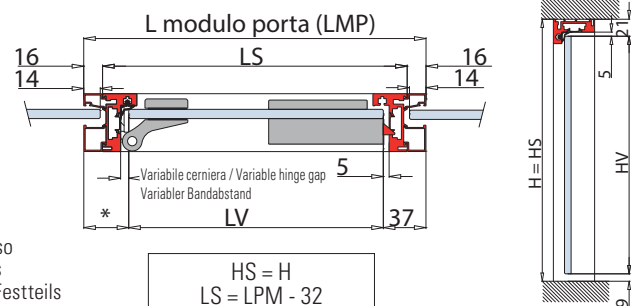

V-409 V-509 V-709 V-809 V-909

$$LV = LMP - (39* + 37)$$

$$HV = H - 30$$

ESEMPIO MONTAGGIO / ASSEMBLY / MONTAGE

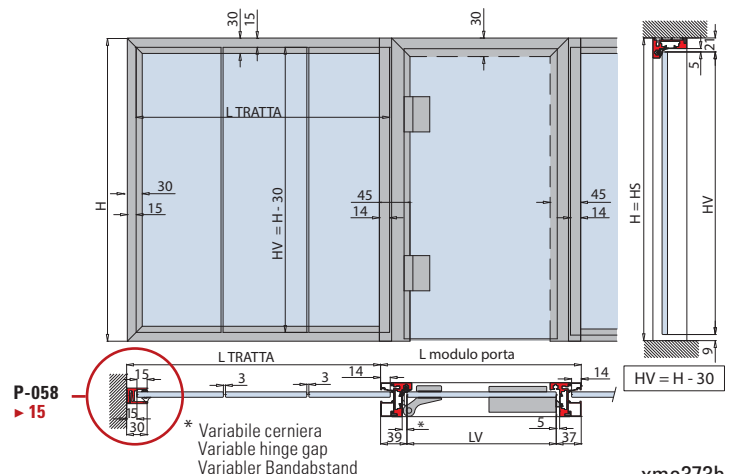
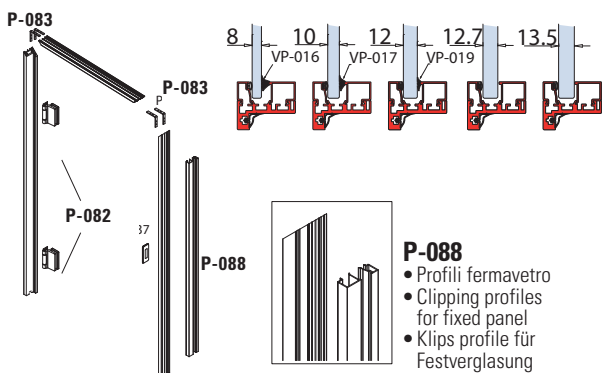

xme373b

P-085-V

€D.240 → €D.250

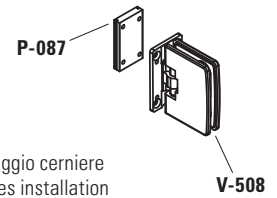
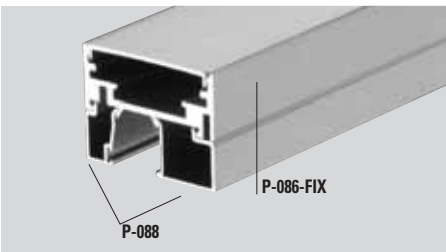

- P-087**
- Per fissaggio cerniere
 - For hinges installation
 - Befestigungsplatte für Bänder

P-088 con/with/mit P-085 or P-086

P-083-CF2

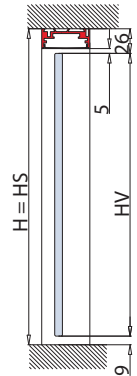
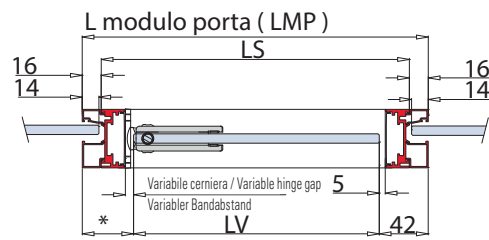
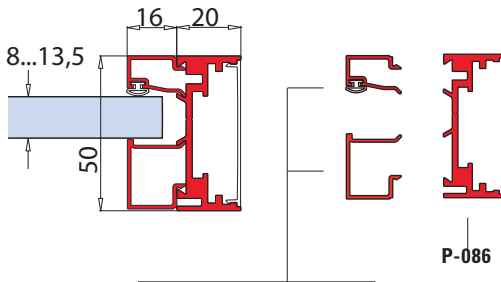

P-088

- Coppia profili L=3000 mm per fissaggio vetro fisso
- Pair clipping profiles L=3000 mm for fixed panels
- Paar Klipsprofile L=3000 mm für Fixierung des Festteils

$$HS = H$$

$$LS = LPM - 32$$

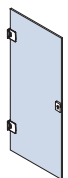

V-508

$$LV = LMP - (44* + 42)$$

$$HV = H - 35$$



B-100

$$LV = LMP - (44* + 42)$$

$$HV = H - 35$$

ESEMPIO MONTAGGIO / ASSEMBLY / MONTAGE

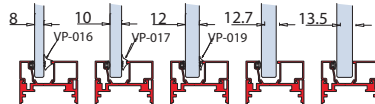
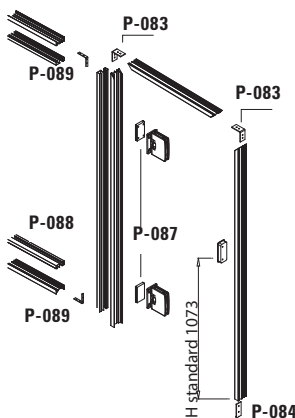

- P-088**
- Profili fermavetro
 - Clipping profiles for fixed panel
 - Klipsprofile für Festverglasung

- P-089**
- Angolare per stipite
 - Bracket
 - Verbinder

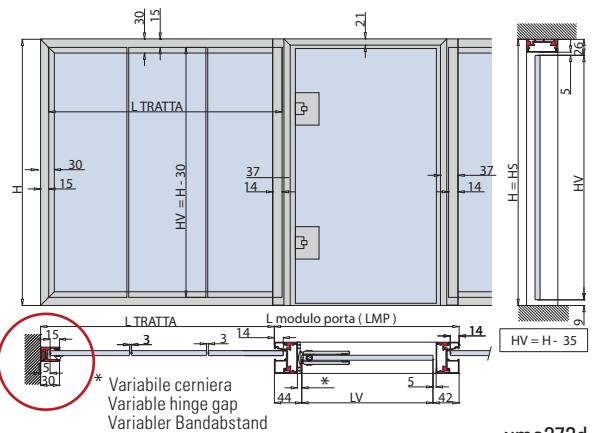

- P-058**
- Variabile cerniera
 - Variable hinge gap
 - Variabler Bandabstand

xme373d



STIPITI SU MURO

ALUMINIUM FRAMES
ALUZARGEN



P-030

► 42

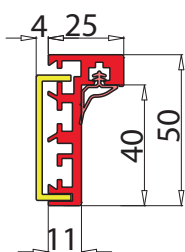

xme373f



P-010

► 44

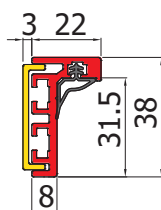

xme557a



P-040

► 45

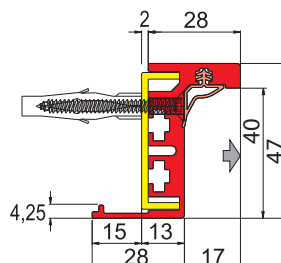

xme373h



P-080-SL

► 46

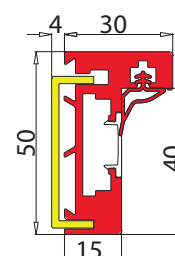

xme373a



P-085

▶ 47



TP-300

▶ 48



TP-250

▶ 49



TS-04

▶ 50

STIPITI SU MURO

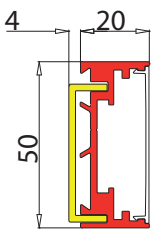

xme373c

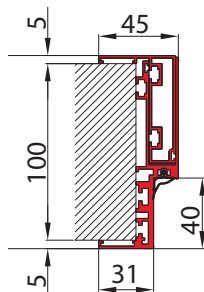

xme373e

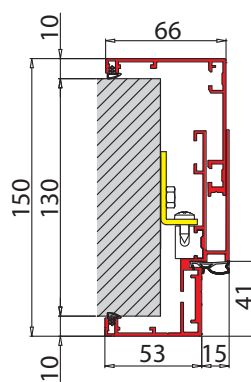

xmc062

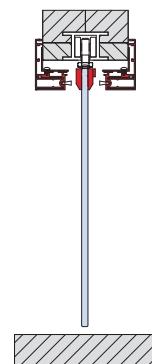

xfb015-1

P-030

€D.188 → €D.199

MY METALGLAS



STIPITI SU MURO

P-030

- Profilo stipite in alluminio anodizzato naturale lavorato a misura cliente. Tagliato a 45°
- Door frame complete in anodised aluminium. Corners cut 45° available in the requested sizes.
- Anschlagtürzarge komplett aus eloxiertem Aluminium, erhältlich in den gewünschten Maßen mit Schnitt 45°

P-031-FIX

- Profilo stipite in alluminio anodizzato naturale fornito in barre, escluse guarnizioni VP-015
- Aluminium door jamb profile natural anodised without gaskets VP-015, supplied in bars.
- Aluminiumprofil Türzarge natur-eloxiert, in Stangen, ohne Dichtungen VP-015

P-012-CF4

- Squadrette per stipite P-030, P-031
- Connectors for profile P-030, P-031
- Verbinder für Profile P-030, P-031

P-033

- Profilo optional per regolazione P-030, P-031
- Optional wall profile for adjustment P-030, P-031
- Wandprofil für Verstellung P-030, P-031

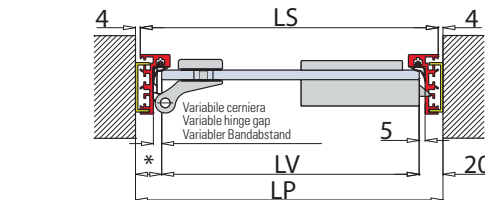
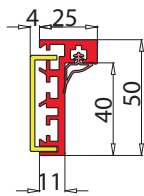

Con/With/Mit **P-033**

$$\begin{matrix} HS = H - 4 \\ LS = LP - 8 \end{matrix}$$

Senza/Without/Ohne **P-033**

$$\begin{matrix} HS = H \\ LS = LP \end{matrix}$$

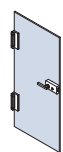
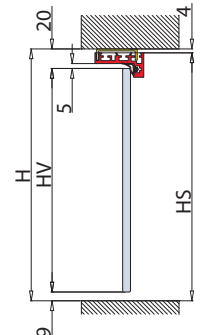

Con/With/Mit **P-033**

V-409 V-509 V-709 V-809 V-909 V-729

$$\begin{matrix} LV = LP - (20 + 22^*) \\ HV = H - 29 \end{matrix}$$

V-701 V-704 V-807

$$\begin{matrix} LV = LP - (20 + 23^*) \\ HV = H - 29 \end{matrix}$$

Senza/Without/Ohne **P-033**

V-409 V-509 V-709 V-809 V-909 V-729

$$\begin{matrix} LV = LP - (16 + 18^*) \\ HV = H - 25 \end{matrix}$$

V-701 V-704 V-807

$$\begin{matrix} LV = LP - (16 + 19^*) \\ HV = H - 25 \end{matrix}$$

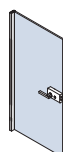

Con/With/Mit **P-033**

P-08

$$\begin{matrix} LV = LP - (20 + 24^*) \\ HV = H - 29 \end{matrix}$$

P-09

$$\begin{matrix} LV = LP - (20 + 20^*) \\ HV = H - 29 \end{matrix}$$

Senza/Without/Ohne **P-033**

P-08

$$\begin{matrix} LV = LP - (16 + 20^*) \\ HV = H - 25 \end{matrix}$$

P-09

$$\begin{matrix} LV = LP - (16 + 16^*) \\ HV = H - 25 \end{matrix}$$



Con/With/Mit **P-033**

P0-200 P0-100

$$\begin{matrix} LA = LP - (20 + 20^*) \\ HA = H - 29 \end{matrix}$$

Senza/Without/Ohne **P-033**

P0-200 P0-100

$$\begin{matrix} LA = LP - (16 + 16^*) \\ HA = H - 25 \end{matrix}$$



STIPTISU
MURO

P-010

€D.200 → €D.206

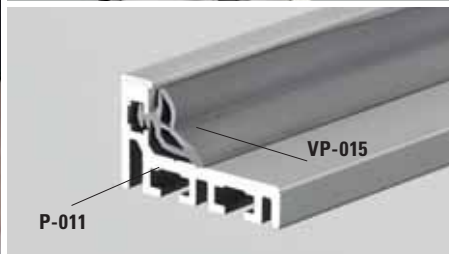

STIPITI SU MURO

P-010

- Profilo stipite in alluminio anodizzato naturale lavorato a misura cliente. Tagliato a 45°
- Door frame complete in anodised aluminium. Corners cut 45° available in the requested sizes.
- Anschlagtürzarge komplett aus eloxiertem Aluminium, erhältlich in den gewünschten Maßen mit Schnitt 45°.

P-011-FIX

- Profilo stipite in alluminio anodizzato naturale fornito in barre, escluse guarnizioni VP-015
- Aluminium door jamb profile natural anodised without gaskets VP-015, supplied in bars.
- Aluminiumprofil Türzarge natur-eloxiert, in Stangen. ohne Dichtungen VP-015.

P-012-CF4

- Squadrette per stipite P-030, P-031.
- Connectors for profile P-030, P-031. Verbinde für Profile P-030, P-031.

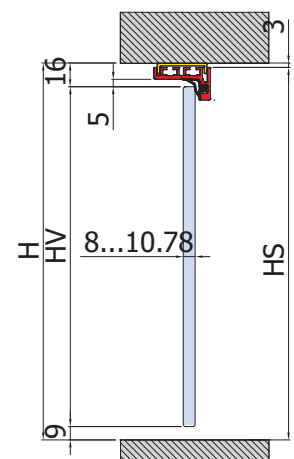
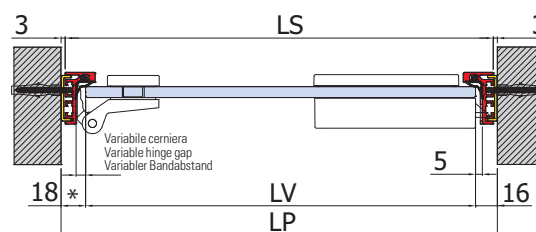
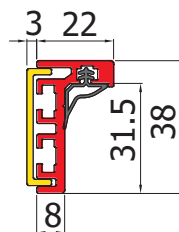

P-034

- Profilo optional per regolazione P-010, P-011
- Optional wall profile for adjustment P-010, P-011
- Wandprofil für Verstellung P-010, P-011

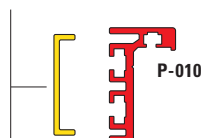

Con/With/Mit **P-034**

$$\begin{aligned} HS &= H - 3 \\ LS &= LP - 6 \end{aligned}$$

Senza/Without/Ohne **P-034**

$$\begin{aligned} HS &= H \\ LS &= LP \end{aligned}$$

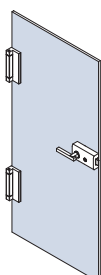

Con/With/Mit **P-034**

V-409 V-509 V-709 V-809 V-909 V-729

$$\begin{aligned} LV &= LP - (18^* + 16) \\ HV &= H - 25 \end{aligned}$$

V-701 V-704

$$\begin{aligned} LV &= LP - (19^* + 16) \\ HV &= H - 25 \end{aligned}$$

Senza/Without/Ohne **P-034**

V-409 V-509 V-709 V-809 V-909 V-729

$$\begin{aligned} LV &= LP - (15^* + 13) \\ HV &= H - 22 \end{aligned}$$

V-701 V-704

$$\begin{aligned} LV &= LP - (16^* + 13) \\ HV &= H - 22 \end{aligned}$$

P-040

€►D.207 → €►D.212

MY METALGLAS

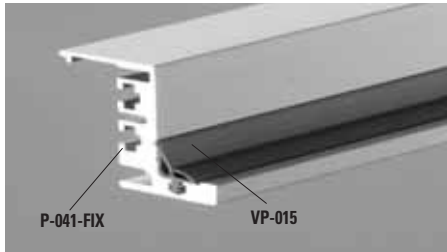

P-040

- Profilo stipite in alluminio anodizzato naturale lavorato a misura cliente. Tagliato a 45°
- Door frame complete in anodised aluminium. Corners cut 45° available in the requested sizes.
- Anschlagtürzarge komplett aus eloxiertem Aluminium, erhältlich in den gewünschten Maßen mit Schnitt 45°.

P-041-FIX

- Profilo stipite in alluminio anodizzato naturale fornito in barre, escluse guarnizioni VP-015.
- Aluminium door jamb profile natural anodised without gaskets VP-015, supplied in bars.
- Aluminiumprofil Türzarge natur-eloxiert in Stangen, ohne Dichtungen VP-015.

P-012-CF4

- Squadrette per stipite P-030, P-031.
- Connectors for profile P-030, P-031.
- Verbinder für Profile P-030, P-031.

P-033

- Profilo optional per regolazione P-040, P-041
- Optional wall profile for adjustment P-040, P-041
- Wandprofil für Verstellung P-040, P-041

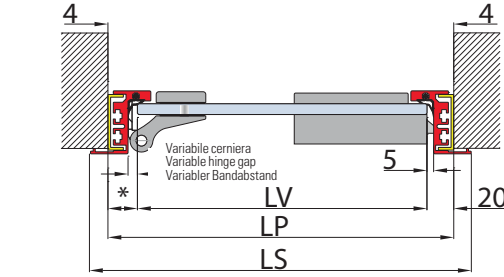
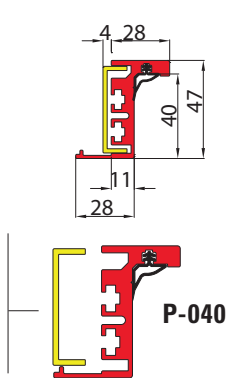

Con/With/Mit P-033

Senza/Without/Ohne P-033

$$\begin{aligned} HS &= H + 13 \\ LS &= LP + 26 \end{aligned}$$

$$\begin{aligned} HS &= H + 17 \\ LS &= LP + 34 \end{aligned}$$

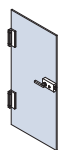
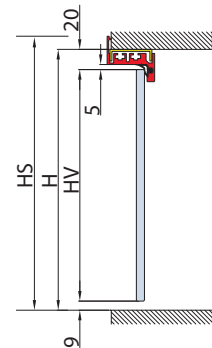

Con/With/Mit P-033

V-409 V-509 V-709 V-809 V-909 V-729
V-701 V-704 V-807

$$\begin{aligned} LV &= LP - (20 + 22^*) \\ HV &= H - 29 \end{aligned}$$

$$\begin{aligned} LV &= LP - (20 + 23^*) \\ HV &= H - 29 \end{aligned}$$

Senza/Without/Ohne P-033

V-409 V-509 V-709 V-809 V-909 V-729
V-701 V-704 V-807

$$\begin{aligned} LV &= LP - (16 + 18^*) \\ HV &= H - 25 \end{aligned}$$

$$\begin{aligned} LV &= LP - (16 + 19^*) \\ HV &= H - 25 \end{aligned}$$

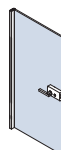

Con/With/Mit P-033

P-08
P-09

$$\begin{aligned} LV &= LP - (20 + 24^*) \\ HV &= H - 29 \end{aligned}$$

$$\begin{aligned} LV &= LP - (20 + 20^*) \\ HV &= H - 29 \end{aligned}$$

Senza/Without/Ohne P-033

P-08
P-09

$$\begin{aligned} LV &= LP - (16 + 20^*) \\ HV &= H - 25 \end{aligned}$$

$$\begin{aligned} LV &= LP - (16 + 16^*) \\ HV &= H - 25 \end{aligned}$$



Con/With/Mit P-033

P0-200 P0-100

$$\begin{aligned} LA &= LP - (20 + 20^*) \\ HA &= H - 29 \end{aligned}$$

Senza/Without/Ohne P-033

P0-200 P0-100

$$\begin{aligned} LA &= LP - (16 + 16^*) \\ HA &= H - 25 \end{aligned}$$

P-080-SL

€>D.225 → €>D.239

MY METALGLAS

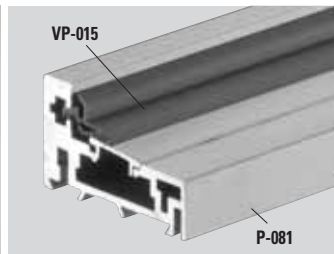
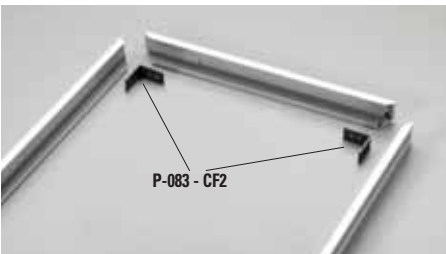
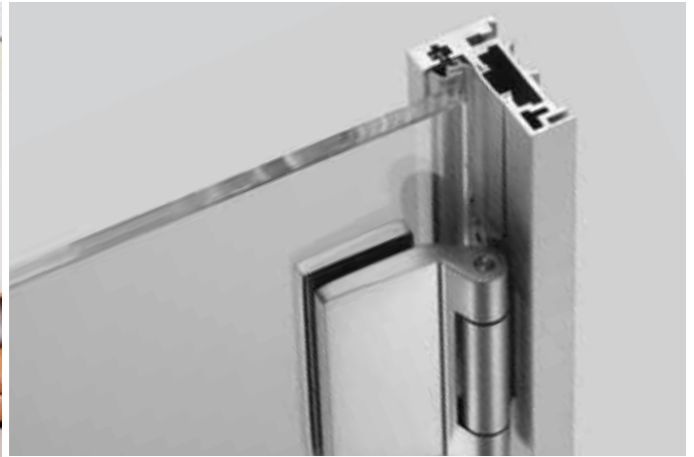

P-080-SL

- Profilo stipite in alluminio anodizzato naturale lavorato a misura cliente. Tagliato a 45°
- Door frame complete in anodised aluminium. Corners cut 45° available in the requested sizes.
- Anschlagtürzarge komplett aus eloxiertem Aluminium, erhältlich in den gewünschten Maßen mit Schnitt 45°

P-081-FIX

- Profilo stipite in alluminio anodizzato naturale fornito in barre, escluse guarnizioni VP-015
- Aluminium door jamb profile natural anodised without gaskets VP-015, supplied in bars
- Aluminiumprofil Türzarge natur-eloxiert in Stangen ohne Dichtungen VP-015.

P-082

- Per fissaggio cerniere
- For hingest installation
- Befestigungsplatte für Bänder

P-033

- Profilo optional per regolazione P-080, P-081
- Optional wall profile for adjustment P-080, P-081
- Wandprofil für Verstellung P-080, P-081

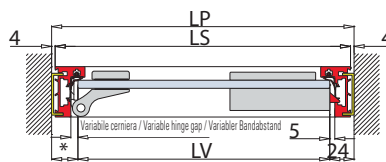
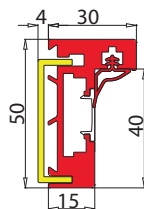

Con/With/Mit **P-033**

$$\begin{aligned} HS &= H - 4 \\ LS &= LP - 8 \end{aligned}$$

Senza/Without/Ohne **P-033**

$$\begin{aligned} HS &= H \\ LS &= LP \end{aligned}$$

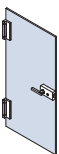
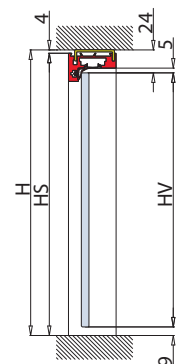

Con/With/Mit **P-033**

V-409 V-509 V-709 V-809 V-909

$$\begin{aligned} LV &= LP - (26^*+24) \\ HV &= H - 33 \end{aligned}$$

Senza/Without/Ohne **P-033**

V-409 V-509 V-709 V-809 V-909

$$\begin{aligned} LV &= LP - (22^*+20) \\ HV &= H - 29 \end{aligned}$$

ESEMPIO MONTAGGIO / ASSEMBLY / MONTAGE

P-083

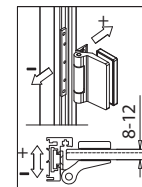
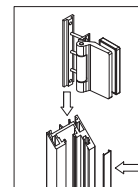
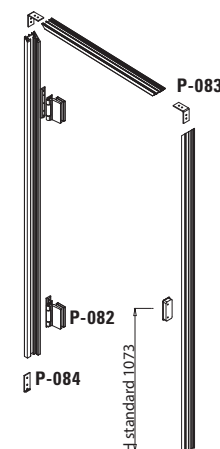

P-082

- Piastrina ad infilare nello stipite per cerniere verticali: V-409, V-509, V-709, V-809. Regolabile in altezza e in profondità per i vari spessori di vetro, cerniere non incluse.
- Fixing plate for hinges V-409, V-509, V-709, V-809 in height and depth, adjustable for different glass thickness. Hinges not included.
- Befestigungsplatte für Bänder V-409, V-509, V-709, V-809, Frei höhen und Tiefenverstellbar für verschiedene Glasstärken. Bänder nicht enthalten

xme373a

P-085

€►D.240 → €►D.250

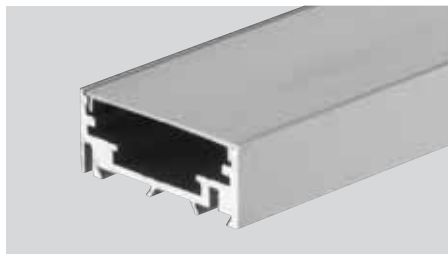
MY METALGLAS

- P-085**
- Profilo stipite in alluminio anodizzato naturale lavorato a misura cliente. Tagliato a 45°
 - Door frame complete in anodised aluminium. Corners cut 45° available in the requested sizes.
 - Anschlagtürzarge komplett aus eloxiertem Aluminium, erhältlich in den gewünschten Maßen mit Schnitt 45°

- P-086-FIX**
- Profilo stipite in alluminio anodizzato naturale fornito in barre, escluse guarnizioni VP-015
 - Aluminium door jamb profile natural anodised without gaskets VP-015, supplied in bars
 - Aluminiumprofil Türzarge natur-eloxiert in Stangen, ohne Dichtungen VP-015

- P-083-CF2**
- Squdrette per stipite P-085, P-086
 - Connectors for profile P-085, P-086
 - Verbinder für Profile P-085, P-086

- P-033**
- Profilo optional per regolazione P-080, P-081
 - Optional wall profile for adjustment P-080, P-081
 - Wandprofil für Verstellung P-080, P-081

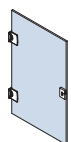
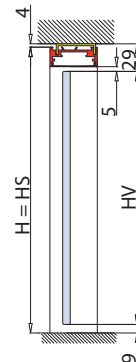
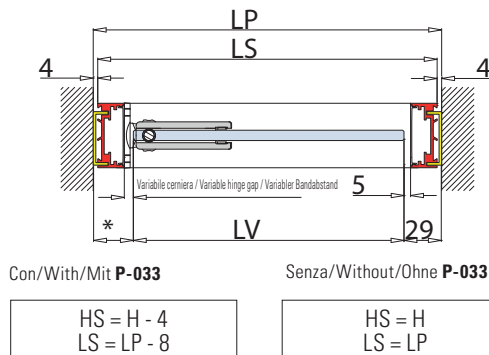
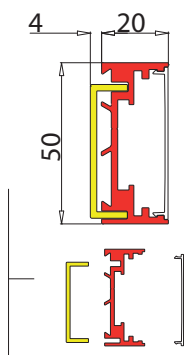
 Con/With/Mit **P-033**
V-508

$$LV = LP - (31*+29)$$

$$HV = H - 38$$

 Senza/Without/Ohne **P-033**
V-508

$$LV = LP - (27*+25)$$

$$HV = H - 34$$

ESEMPIO MONTAGGIO / ASSEMBLY / MONTAGE

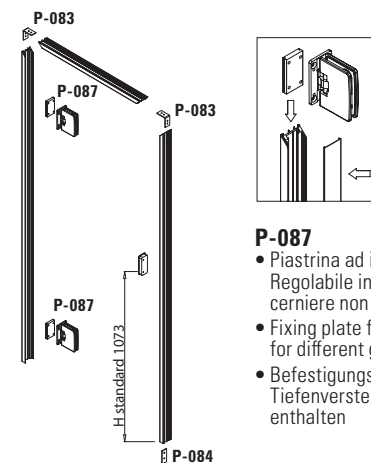

- P-087**
- Piastrina ad infilare nello stipite per cerniere verticali V-508. Regolabile in altezza e in profondità per i vari spessori di vetro, cerniere non incluse.
 - Fixing plate for hinges V-508 in height and depth, adjustable for different glass thickness. Hinges not included.
 - Befestigungsplatte für Bänder V-508, Frei höhen und Tiefenverstellbar für verschiedene Glasstärken Bänder nicht enthalten

xme373c

TP-300 IMBOTTE

€▶D.213 → €▶D.219



TP-300

- Profilo stipite in alluminio anodizzato naturale lavorato a misura cliente con taglio 45 e fornito completo con guarnizione e squadrette.
- Door frame complete in anodised aluminium for hinged doors, available in the requested sizes, corners cut 45°. Complete with gasket, connectors.
- Anschlagtürzarge komplett aus eloxiertem Aluminium, erhältlich in den gewünschten Maßen mit Schnitt 45° Komplett mit Dichtung und Verbinder.

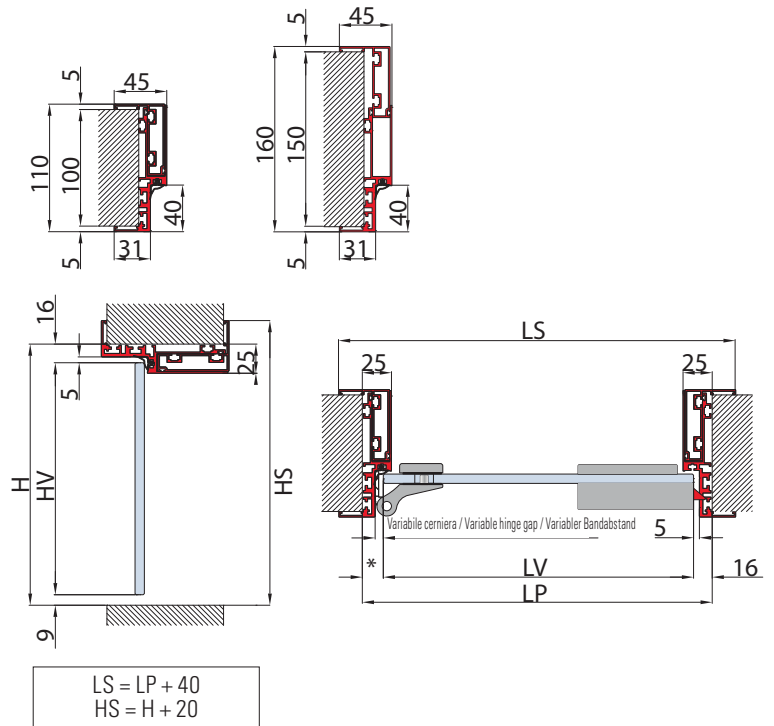

- Adatto per muratura da 100 a 150 mm.
- 100 - 150 mm Min Max adjustable wall thickness.
- 100 - 150 mm Min-Max Verstellung für Wandstärken.

€▶ D.03

STIPITI SU MURO

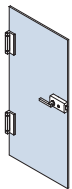

V-409 V-509 V-709 V-809 V-909 V-729

$$LV = LFM - (16 + 18^*)$$

$$HV = HFM - 25$$

V-701 V-704 V-807

$$LV = LFM - (16 + 19^*)$$

$$HV = HFM - 25$$

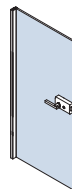

P-08

$$LV = LFM - (16 + 19^*)$$

$$HV = HFM - 25$$

P-09

$$LV = LFM - (16 + 15^*)$$

$$HV = HFM - 25$$



P0-200 P0-100

$$LA = LFM - (16 + 16^*)$$

$$HA = HFM - 25$$

ESEMPIO MONTAGGIO / ASSEMBLY / MONTAGE

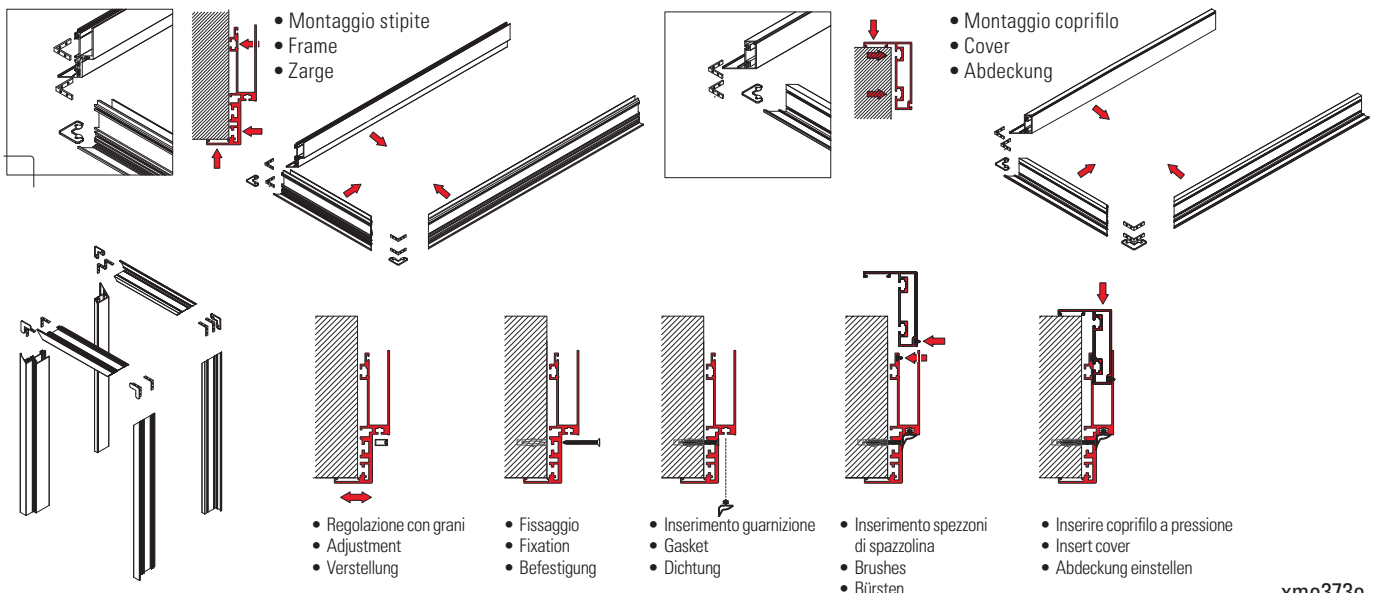

TP-250

€▶D.220 → €▶D.224

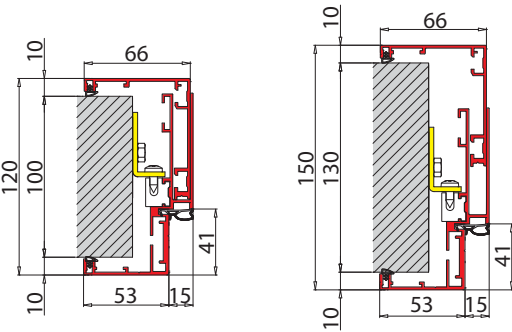
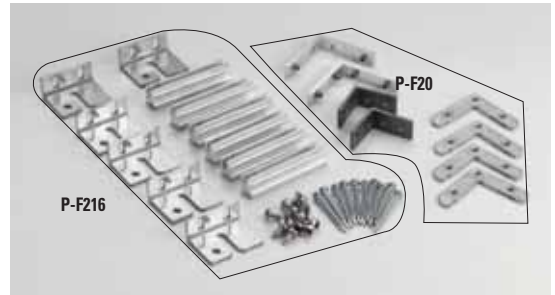
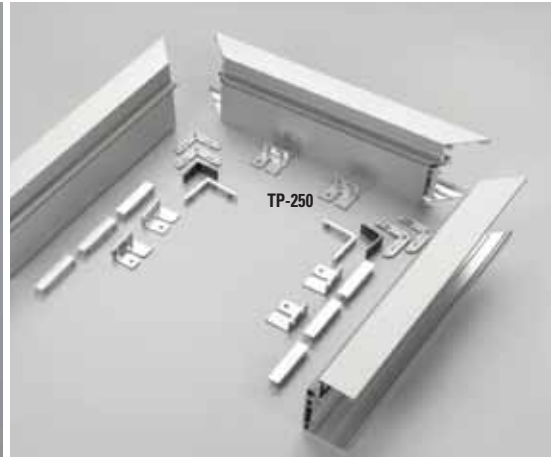

- Adatto per muratura da 100 a 130 mm.
- 100 - 130 mm Min Max adjustable wall thickness.
- 100 - 130 mm Min-Max Verstellung für Wandstärken.

STIPITI SU MURO

LP Larghezza Width Breite	H Altezza Height Höhe	Passaggio netto Larghezza Width Breite	Passaggio netto Altezza Height Höhe
800	2050	720	2010
	2150		2110
900	2050	820	2010
	2150		2110
1000	2050	920	2010
	2150		2110

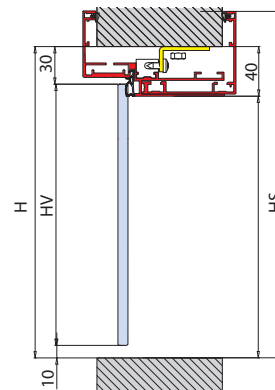
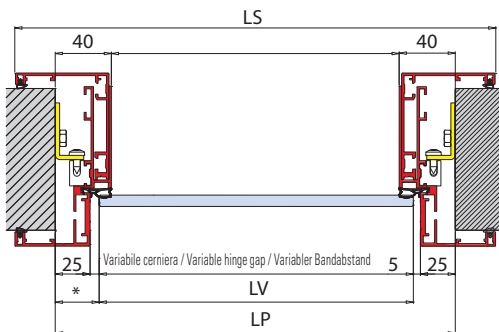

$$LV = LP - (30 + 30^*)$$

$$HV = H - 40$$

$$LS = LP + 56$$

$$HS = H + 28$$

TS-04

TELAIO IN ALLUMINIO PER PORTA A SCOMPARSA
ALUMINIUM FRAME FOR FLUSH POCKET SLIDING DOOR / ALUZARGE FÜR SCHIEBETÜREN IN DER WAND LAUFEND

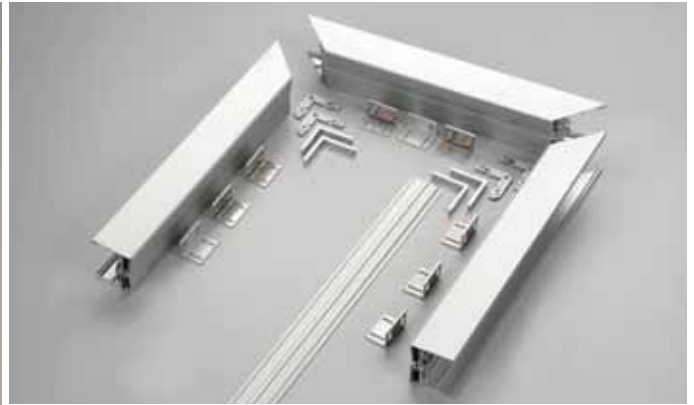

TS-04- ACCESS

- Anta tutto-vetro con pinze V-011.
- With frameless glass door and clamps V-011.
- Mit Ganzglasschiebetüren und V-011 Klemmen.

€▶D.251

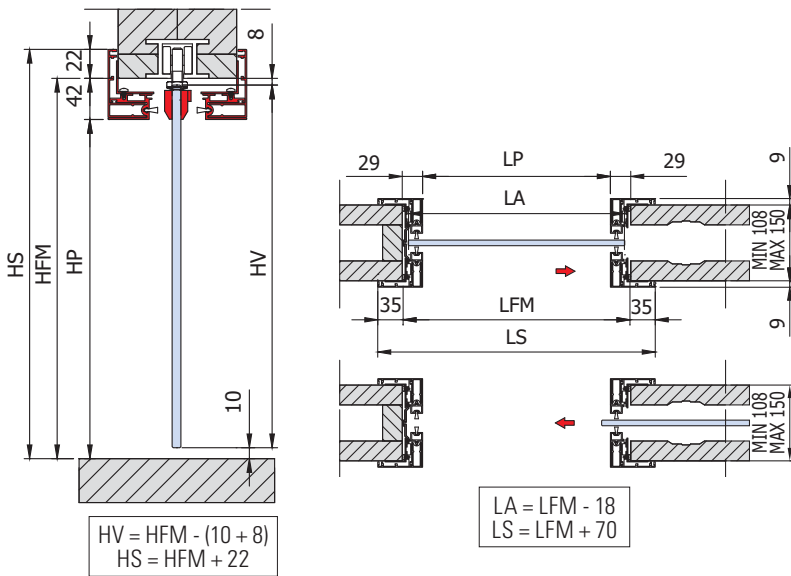

TS-04 ANTA VETRO					
VERSIONE CON ANTA IN VETRO					
VERSION WITH FRAMELESS DOOR					
MIT GANZGLASSCHIEBETÜREN					
VETRO GLASS GLAS		FORO SU MURO WALLING UP HOLE EINBAULICHTE		LUCE PASSAGGIO PASSAGE CLEARANCE DURCHGANG	
LV	HV	LFM	HFM	LP	HP
Larghezza Width Breite	Altezza Height Höhe	Larghezza Width Breite	Altezza Height Höhe	Larghezza Width Breite	Altezza Height Höhe
625	2028	650	2050	580	2004
	2128		2150		2104
725	2028	750	2050	680	2004
	2128		2150		2104
825	2028	850	2050	780	2004
	2128		2150		2104
925	2028	950	2050	880	2004
	2128		2150		2104
1025	2028	1050	2050	980	2004
	2128		2150		2104
1125	2028	1150	2050	1080	2004
	2128		2150		2104
1225	2028	1250	2050	1180	2004
	2128		2150		2104

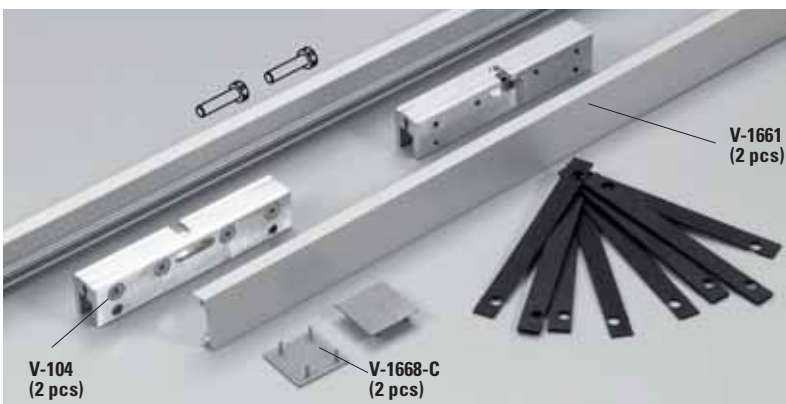

V-1664-1 (L=1000 mm) V-1664-1,5 (L=1500 mm)

- Pinza V-1664 disponibile per telaio in alluminio TS-04
- Clamp V-1664 available for aluminium door frame TS-04
- Klemmen V-1664 verfügbar für aluzarge TS-04

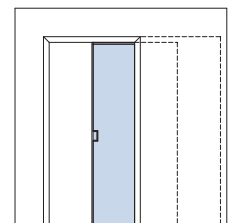

- CONTROTELAIO NON FORNITO
- POCKET SYSTEM NOT SUPPLIED
- KASTENSYSTEM NICHT EINSCHL

€▶D.253

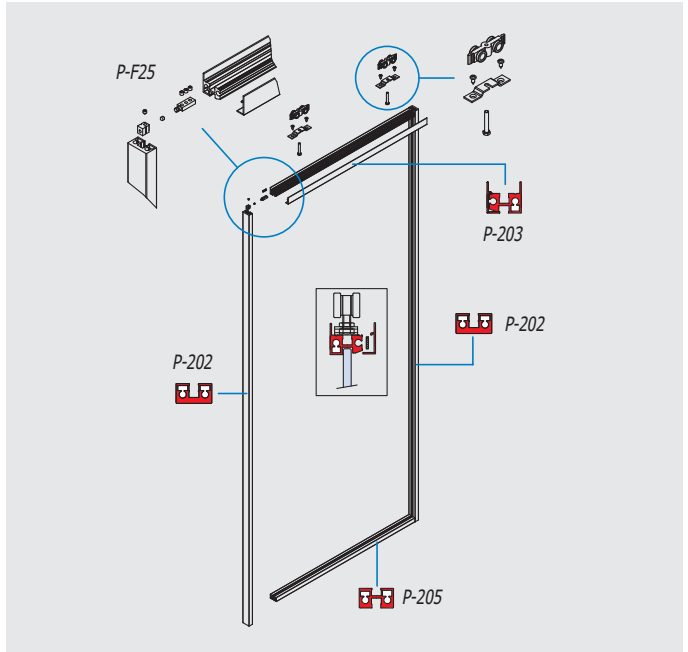
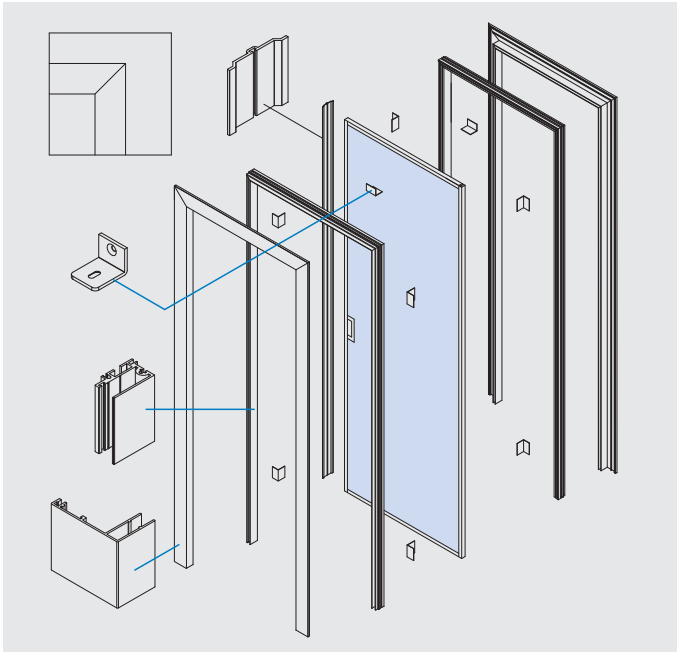

- Anta inteiata P0-290
- Door with aluminium panel P0-290.
- Schiebetür mit Aluminium Flügelrahmen P0-290.

€▶D.252

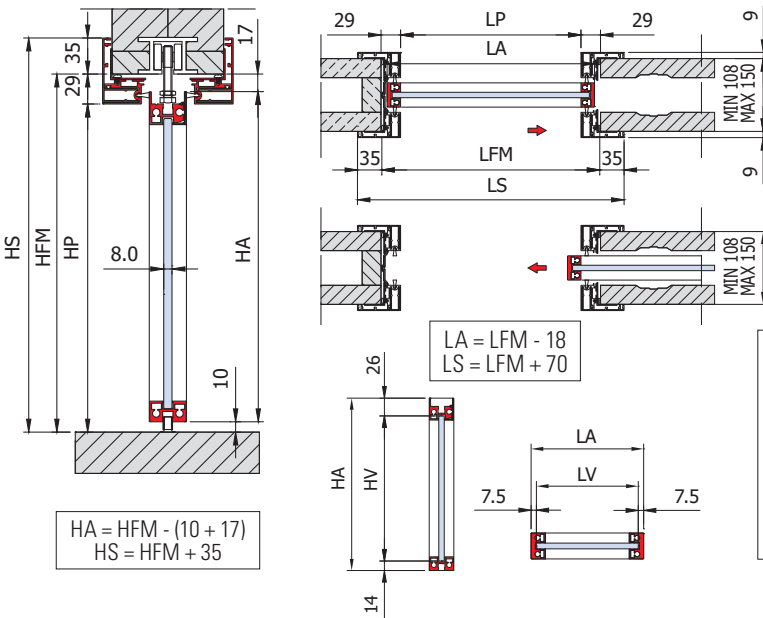

TS-04 ANTA INT					
VERSIONE CON PORTA INTEIATA PO-290					
VERSION WITH ALUMINIUM SLIDING DOOR PO-290					
MIT ALUMINIUM FLÜGELRAHMEN PO-290					
PANNELLO PANEL FLÜGEL		FORO SU MURO WALLING UP HOLE EINBAULICHTE		LUCE PASSAGGIO PASSAGE CLEARANCE DURCHGANG	
LA	HA	LFM	HFM	LP	HP
Larghezza Width Breite	Altezza Height Höhe	Larghezza Width Breite	Altezza Height Höhe	Larghezza Width Breite	Altezza Height Höhe
625	2023	650	2050	580	2021
	2123		2150		2121
725	2023	750	2050	680	2121
	2123		2150		2121
825	2023	850	2050	780	2021
	2123		2150		2121
925	2023	950	2050	880	2021
	2123		2150		2121
1025	2023	1050	2050	980	2021
	2123		2150		2121
1125	2023	1150	2050	1080	2021
	2123		2150		2121
1225	2023	1250	2050	1180	2021
	2123		2150		2121

TS-03 €▶D.254

- Set profili legno grezzo verniciabili dal cliente per controtelai standard rasoparete (non forniti)
- Wooden profiles, paintable by customer, for flush pocket sliding doors systems (not supplied)
- Holz Profile, lackierbar, für in der Wand laufende Türen mit Kastenrahmensystem (nicht einschl.)

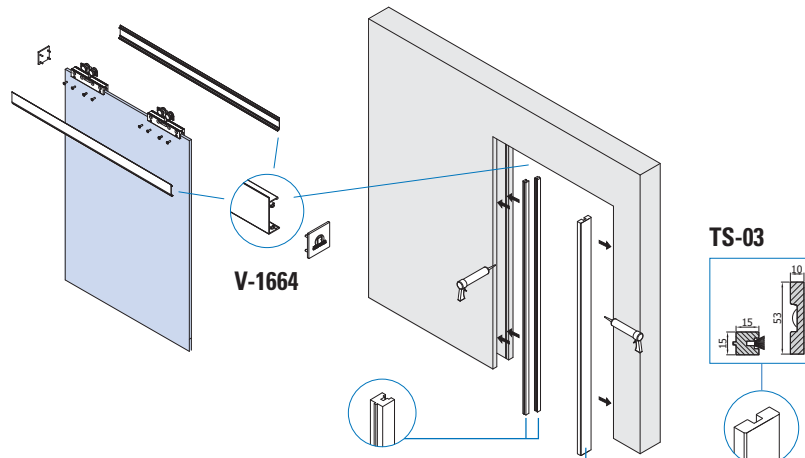

xme501

V-1664

PINZA H30 PER SCORREVOLI A SCOMPARSA

CLAMP H30 FOR FLUSH POCKET SLIDING DOOR SYSTEMS / H30 KLEMMSCHUHE FÜR IN DER WAND LAUFENDE TÜREN

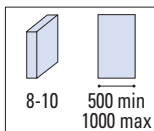

COMPONENTI / COMPONENTS / EINZELTEILE

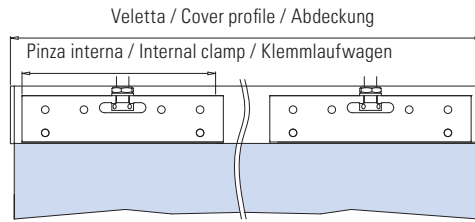
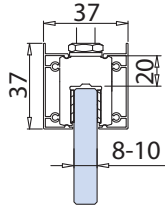
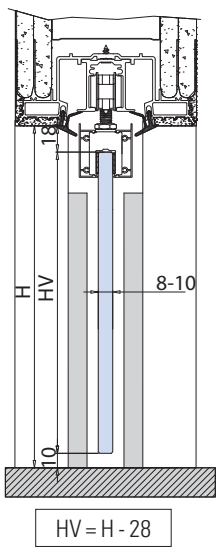

- NB**
- Controtelaio non incluso
 - Pocket system not included
 - Kastenrahmensystem nicht einschl.

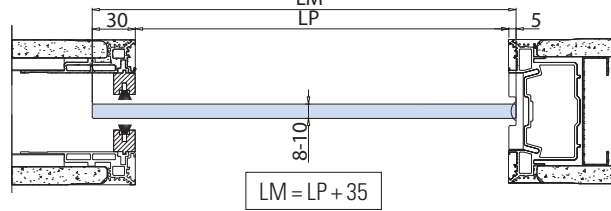

LAVORAZIONE VETRO GLASS PREPARATION GLASBEARBEITUNG

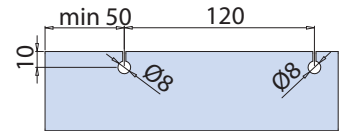

OPTIONAL (x 2)

V-1664-1 (L=1000 mm) V-1664-1,5 (L=1500 mm)

- Pinze per set scorrevole con vellette di copertura e tappi
- Semi-visible kit with clamps and cover profiles and endcaps
- Halb-sichtbares Set von Klemmschuhe mit Abdeckungen und Endkappen

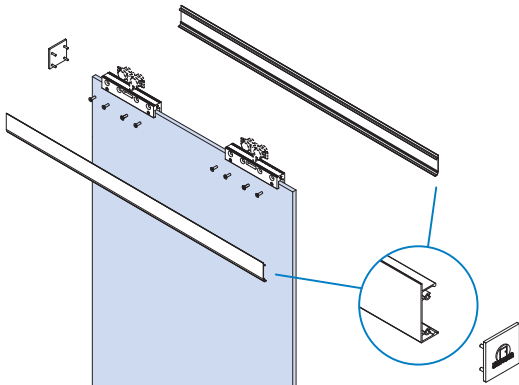

€▶D.253



V-1661-1 (L=1000 mm) V-1661-1,5 (L=1500 mm)

- Kit 2 vellette per pinza V-104
- Kit 2 cover profiles for clamp V-104
- Kit 2 Abdeckungen für Klemmschuh V-104

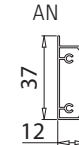

€▶D.259

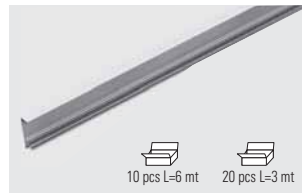

V-1662-3 (L=3000 mm) V-1662-6 (L=6000 mm)

- Veletta per pinza V-104
- Cover profile for clamp V-104
- Abdeckung für Klemmschuh V-104

AN

€▶D.260



V-104

- Pinza per vetro 8-10 mm
- Clamp for sliding door 8/10 mm without holes
- Klemmschuh für 8/10 mm Glas

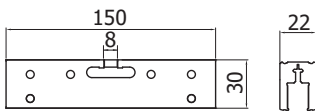

€▶D.255



V-1668-C

- Paio tappi chiusi per vellette V-1661
- Pair closed endcaps for cover profiles V-1661
- Paar geschlossene Endkappen für Abdeckungen V-1661

€▶D.257

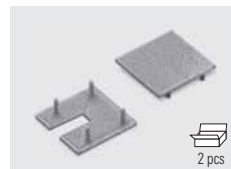

V-1668 (OPTIONAL)

- Paio tappi (1 aperto e 1 chiuso) per vellette V-1661
- Pair endcaps (1 open and 1 closed) for cover profiles V-1661
- Paar Endkappen (1 geöffnet und 1 geschlossen) für Abdeckungen V-1661

€▶D.256

xme501

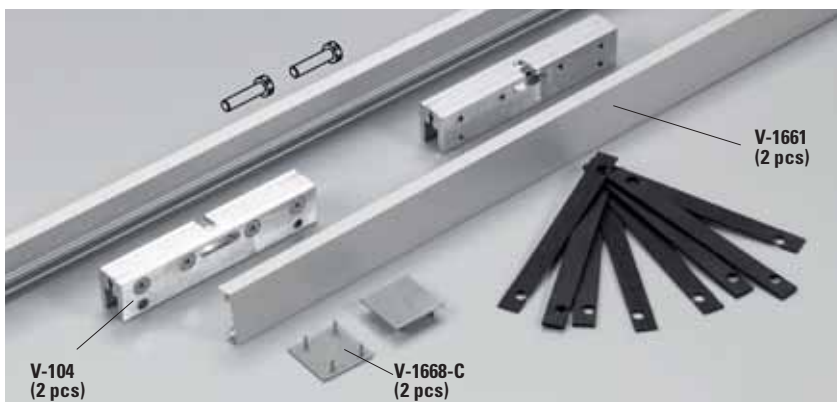

V-1664-1 (L=1000 mm) V-1664-1,5 (L=1500 mm)

- Set di 2 pinze compreso di vellette e tappi per 1 anta scorrevole
- Set of 2 clamps with cover profiles and endcaps for 1 sliding panel
- Set von 2 Klemmen mit Abdeckungen und Endkappen für 1 Schiebetür

AN

€▶D.253

PORTE INTELAIATE

DOORS WITH ALUMINIUM PANEL
ALUMINIUM FLÜGELRAHMEN



PO-200

► 56



PO-100

► 58

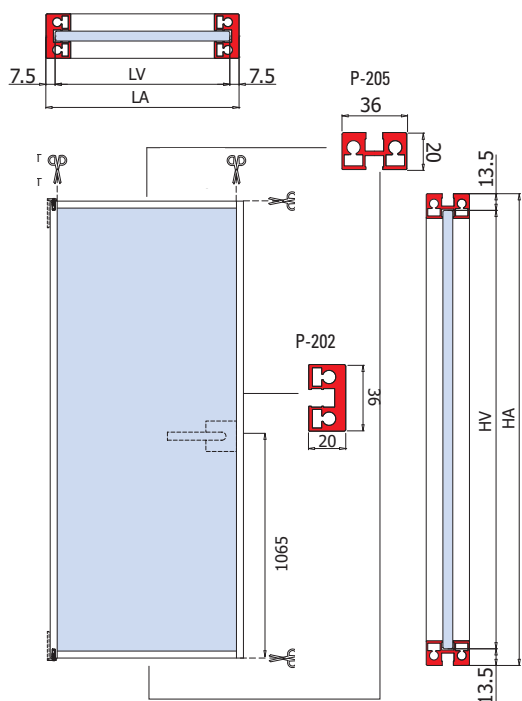

xme199h / xme199d

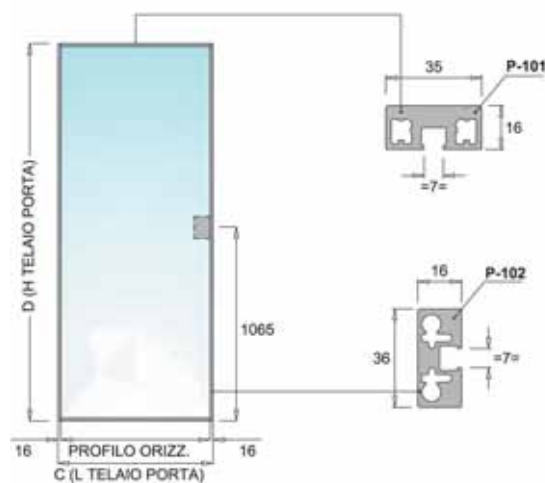

xme407

STIPITI RASOMURO

ALIGNED WITH THE WALL FRAMES
 WANDBÜNDIGE ALUZARGEN



PO-060

► 60

PO-070

► 61

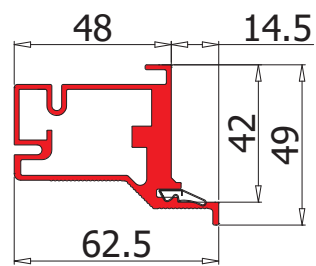
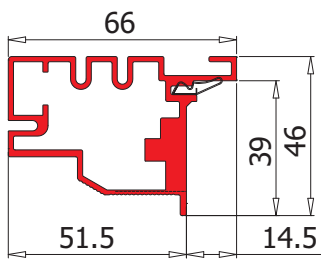

STIPITI SU
 MURO

PO-200

€▶D.261 → €▶D.268

• Porta battente intelaiata
in alluminio. Profili da incollare al vetro.

• Door with Aluminium panel.
Profiles to be glued on glass.

• Drehtür mit Flügelrahmen aus Aluminium.
Profile auf das Glas kleben.



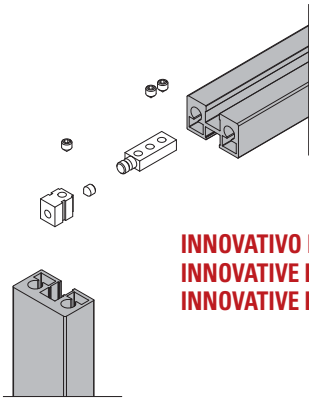

INNOVATIVO PRATICO VELOCE
INNOVATIVE PRATICAL FAST
INNOVATIVE PRAKTISCHE SCHNELL

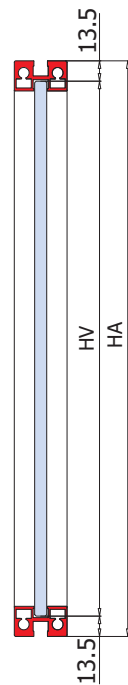
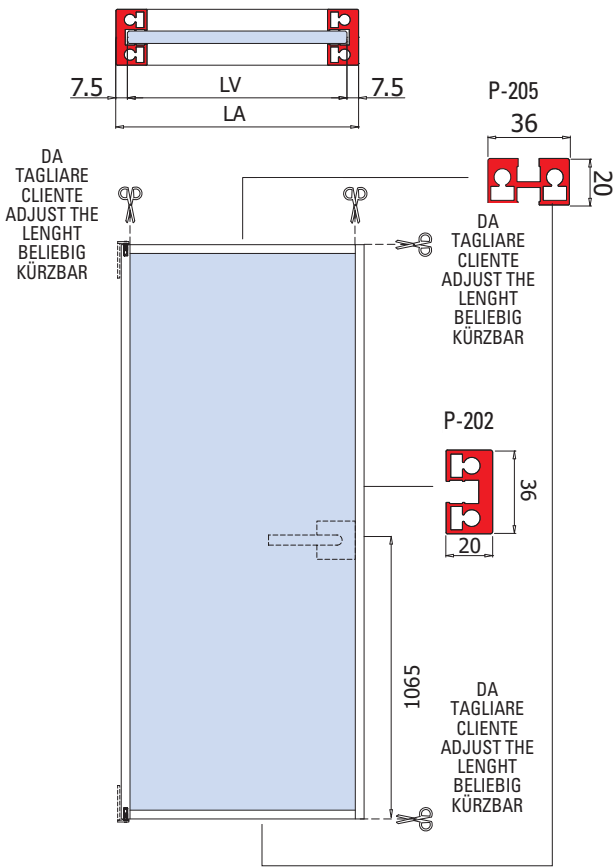
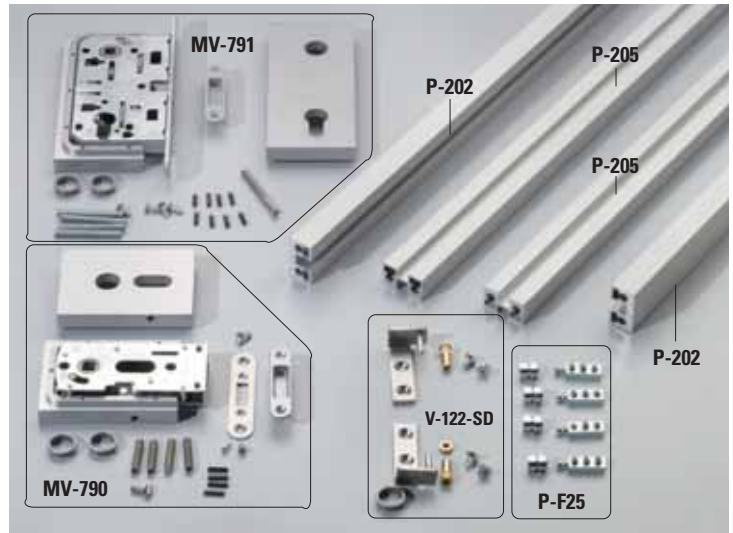

P-F25

- Ferramenta per assemblaggio 1 telaio anta PO-200.
- Fixing materials to assembly one panel PO-200.
- Befestigungsmaterial für Montage Flügelrahmen PO-200.

LV = LA - 15
 HV = HA - 27

V-122-SD

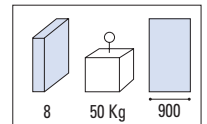
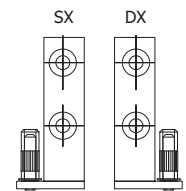

xme199h / xme199d

MV-790 PZ

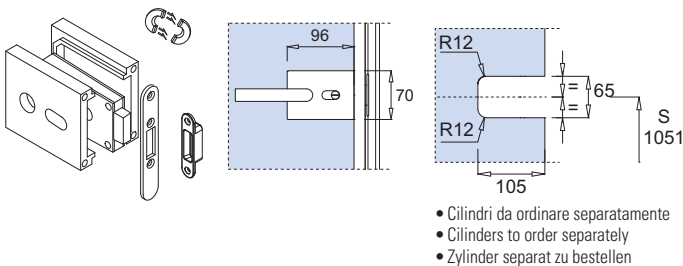

V-791 PZ / MV-791 PZ

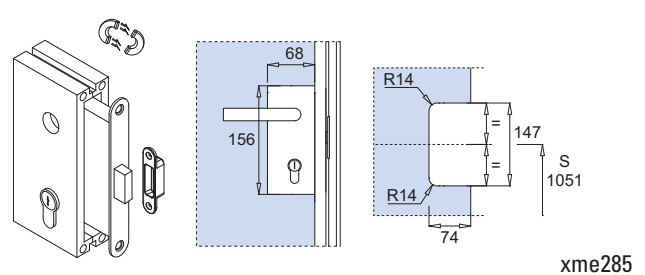

P-204-CF2

- Traversino orizzontale per anta intelaiata in alluminio PO-200/PO-290, da incollare al vetro con biadesivo in dotazione. Prezzo a confezione di 2 barre L=1160 mm
 - Horizontal cross profile with self-adhesive for aluminium panel PO-200/PO-290 Price each package unit of 2 bars L=1160 mm
 - Horizontal Querprofil selbstklebend für Flügelrahmen aus Aluminium PO-200/PO-290. Preis pro VE von 2 Stangen L=1160 mm
- AN

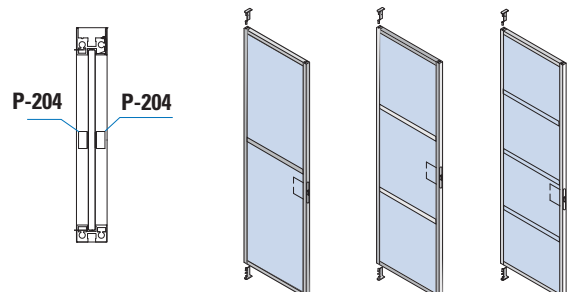
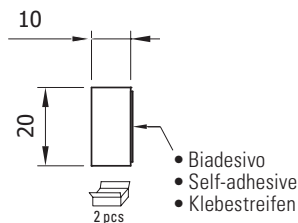

PO-100

€▶D.269 → €▶D.280

• Set telaio anta per porta battente in finitura alluminio anodizzato.

• Set door panel surround in anodised aluminium.

• Set Flügelrahmen aus Aluminium.



STIPITI SU
MURO

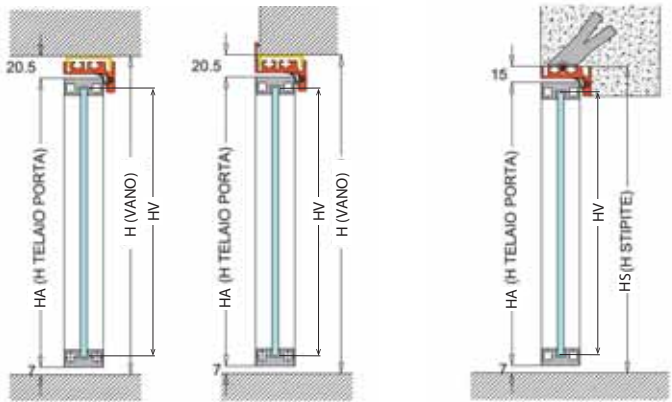
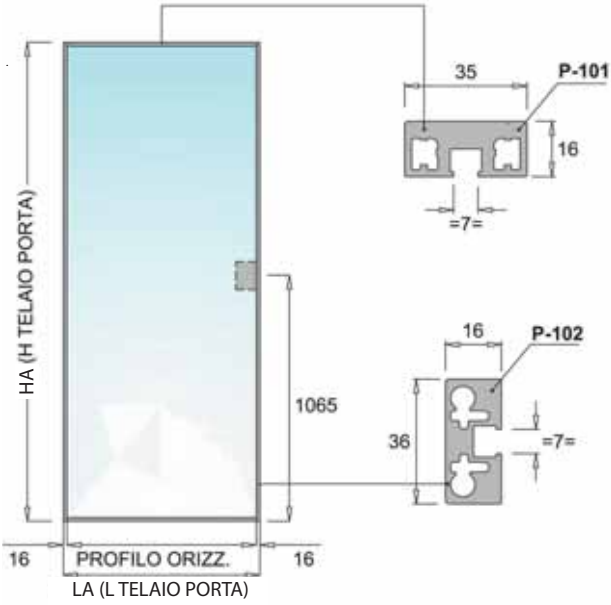
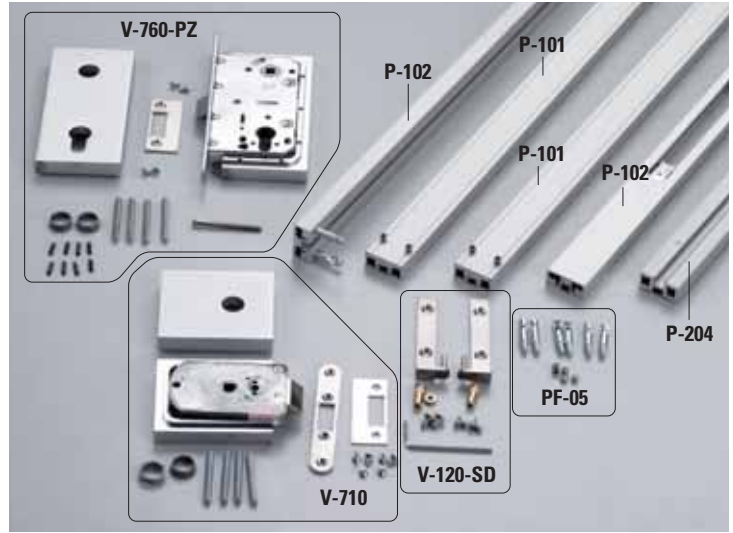
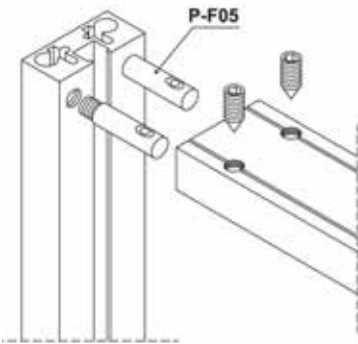

$$HA \text{ (H TELAIO PORTA)} = H - 30.5$$

$$HA \text{ (H TELAIO PORTA)} = HS - 25$$

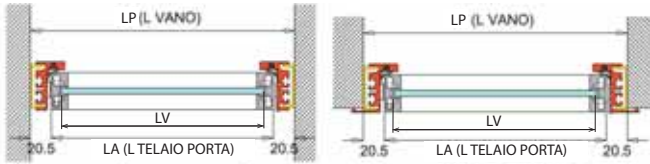

$$LA \text{ (TELAIO PORTA)} = LP - 41$$

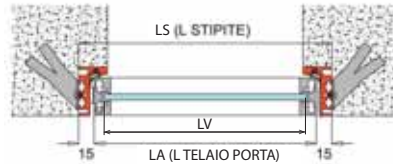

$$LA \text{ (TELAIO PORTA)} = LS - 30$$

$$HV = HA - 19$$

$$LV = LA - 19$$

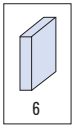

xme407

V-710

- Serratura Compact per telaio porta PO-100.
- Compact lock for PO-100.
- Compact Schloss für Alurahmen PO-100.

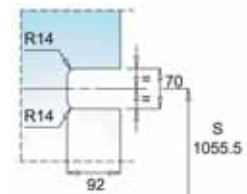
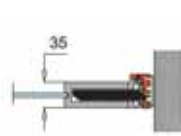
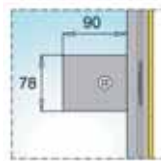
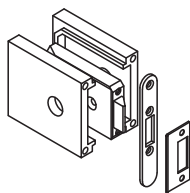

xme408

V-760PZ

- Serratura verticale con foro cilindro per porta PO-100.
- Vertical lock with profile cylinder hole for PO-100.
- Vertikal Schloss PZ Lochung für PO-100.

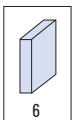
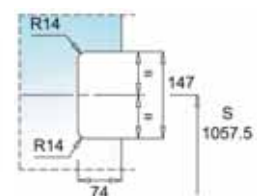
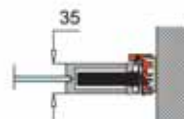
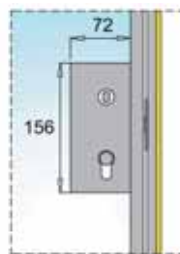
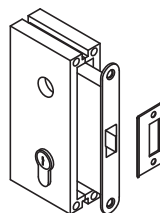

xme408

P-060

€ D.298 → € D.303

STIPITI RASOMURO A TIRARE / ALUMINIUM FRAME OPENING TO PULL / ALUZARGE NACH AUSSEN ÖFFNEND

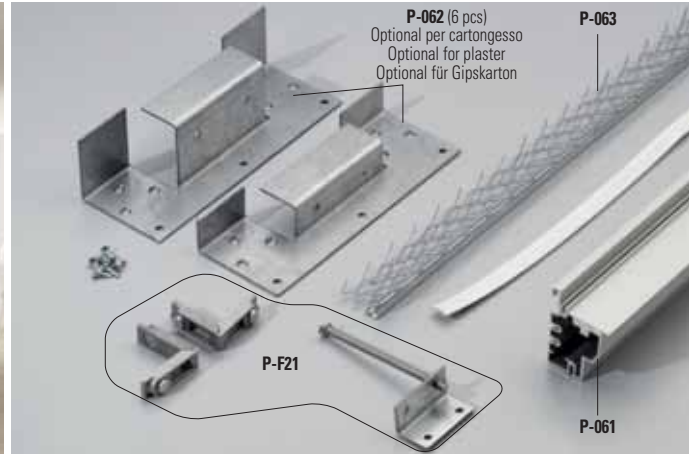

- Stipiti rasomuro a tirare, applicazione su cartongesso o su muratura.
- Aligned with the wall aluminium frame, opening to pull, which can be to the wall or plastered over.
- Wandbündige Aluzarge, nach aussen öffnend, die verputzt bzw gestrichen werden kann.

STIPITI SU MURO

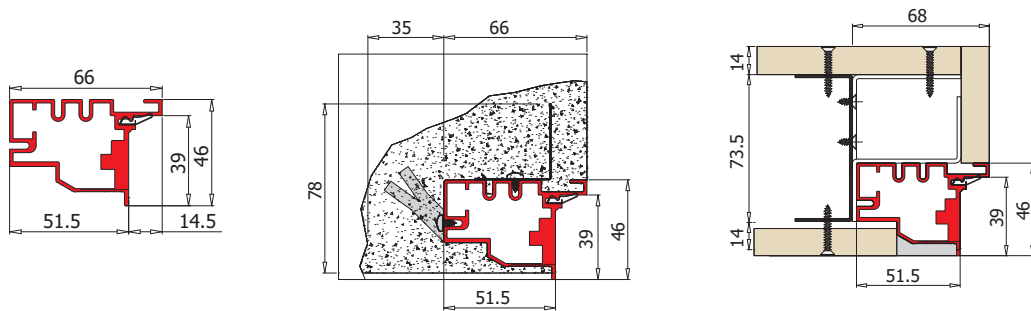

- Applicazione su cartongesso
- Application to the plaster
- Für Gipskarton

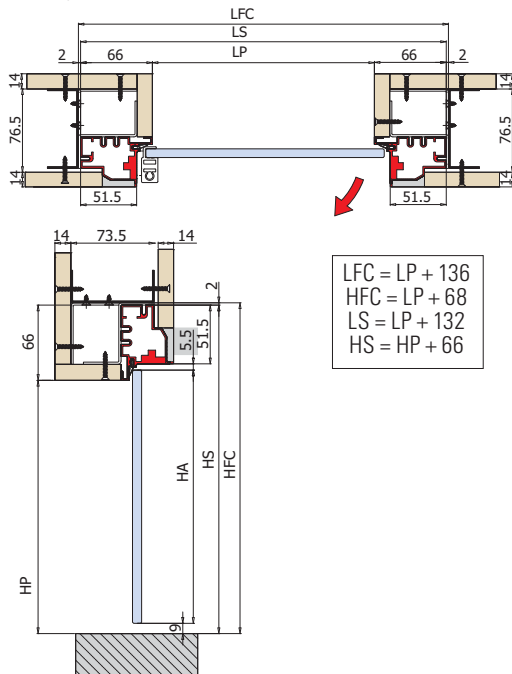

- Applicazione su muratura
- Application to the wall
- Zum Einmauern

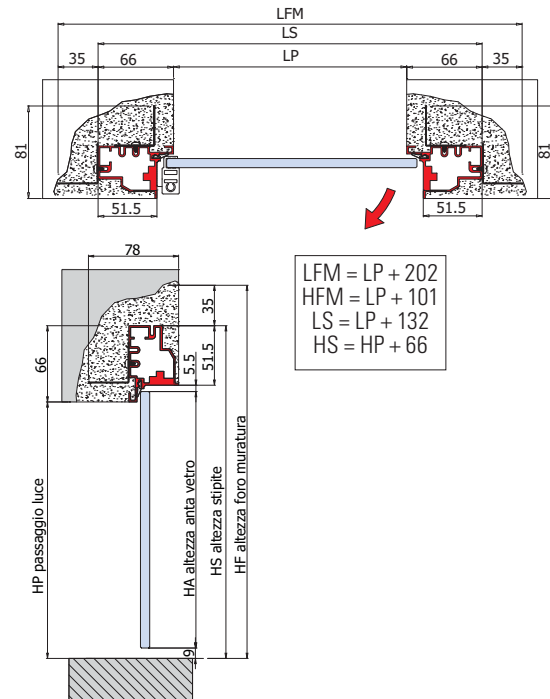

	LFC - HFC		LFM - HFM		LP - HP		LS - HS	
	Foro su cartongesso Plaster hole		Foro su muratura Walling up hole		Luce passaggio Passage clearance		Ingombro stipiti Jamb's dimensions	
	larghezza width	altezza height	larghezza width	altezza height	larghezza width	altezza height	larghezza width	altezza height
Porte standard	836	2168	902	2201	700	2100	832	2166
Standard doors	936	2168	1002	2201	800	2100	932	2166
	1036	2168	1102	2201	900	2100	1032	2166

P-070

€▶D.304 → €▶D.309

STIPITI RASOMURO A SPINGERE / ALUMINIUM FRAME OPENING TO PUSH / ALUZARGE NACH INNEN ÖFFNEND

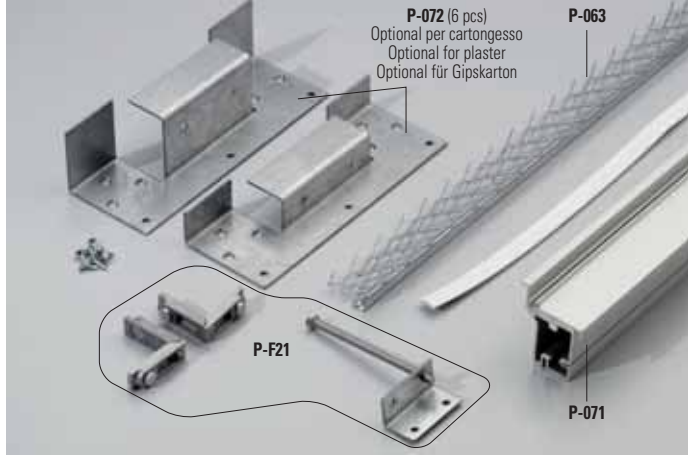

- Stipiti rasomuro a spingere, per applicazione. Porta su cartongesso o muratura.
- Aligned with the wall aluminium frame, opening to push, which can be to the wall or plastered over.
- Wandbündige Aluzarge, nach innen öffnend, die verputzt bzw gestrichen werden kann.

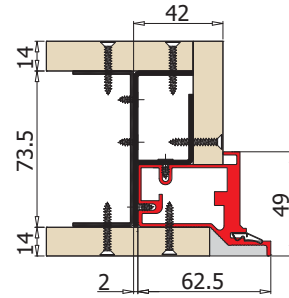
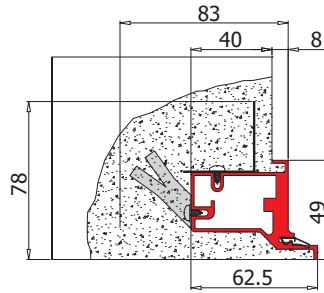
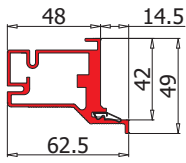

- Applicazione su cartongesso
- Application to the plaster
- Für Gipskarton

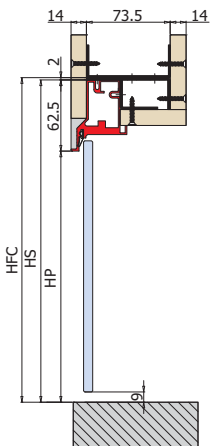
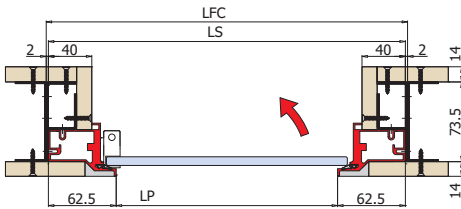

$$\begin{aligned} \text{LFC} &= \text{LP} + 129 \\ \text{HFC} &= \text{LP} + 65 \\ \text{LS} &= \text{LP} + 125 \\ \text{HS} &= \text{HP} + 62.5 \end{aligned}$$

- Applicazione su muratura
- Application to the wall
- Zum Einmauern

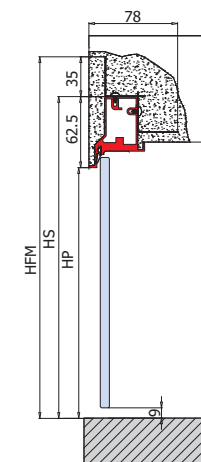
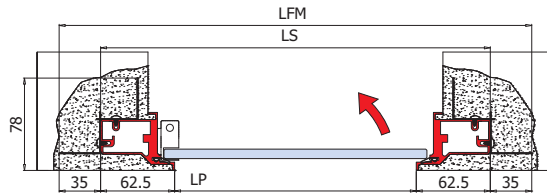

$$\begin{aligned} \text{LFM} &= \text{LP} + 195 \\ \text{HFM} &= \text{LP} + 98 \\ \text{LS} &= \text{LP} + 125 \\ \text{HS} &= \text{HP} + 62.5 \end{aligned}$$

	LFC - HFC		LFM - HFM		LP - HP		LS - HS	
	Foro su cartongesso Plaster hole		Foro su muratura Walling up hole		Luce passaggio Passage clearance		Ingombro stipiti Jamb's dimensions	
	larghezza width	altezza height	larghezza width	altezza height	larghezza width	altezza height	larghezza width	altezza height
Porte standard	830	2165	895	2198	700	2100	825	2163
Standard doors	930	2165	995	2198	800	2100	925	2163
	1030	2165	1095	2198	900	2100	1025	2163

STIPITI SU MURO

SERRATURE E CERNIERE
LOCKS AND HINGES
SCHLÖSSER UND BÄNDER

E

E

GUIDA TECNICA PER LA SCELTA DEL VOSTRO SISTEMA

TECHNICAL GUIDE FOR THE CHOICE OF YOUR SYSTEM
AUSWAHL VON SYSTEME NACH VORHANDENEN KRITERIEN

**SERRATURE ORIZZONTALI
PER PORTE BATTENTI**
**HORIZONTAL LOCKS
FOR SWING DOORS**
**HORIZONTALE SCHLÖSSER
FÜR DREH-TÜREN**

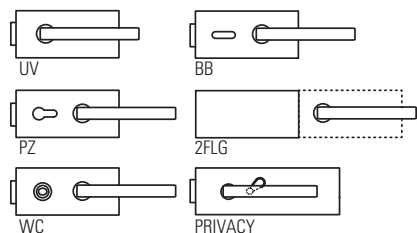

**V-230
BASIC ROUND**
▶ 76



**V-730
BASIC SQUARE**
▶ 78



**V-200 ECO
MV-200 ECO**
▶ 80



**V-720
MV-720**
LIBRA
▶ 82



**V-720 ECO
MV-720 ECO**
▶ 83



**V-400
MV-400**
FERRARI
▶ 116



**V-100
MV-100**
ONE
▶ 117



**SERRATURE VERTICALI
PER PORTE BATTENTI**
**VERTICAL LOCKS
FOR SWING DOORS**
**VERTIKALE SCHLÖSSER
FÜR DREH-TÜRENTI**

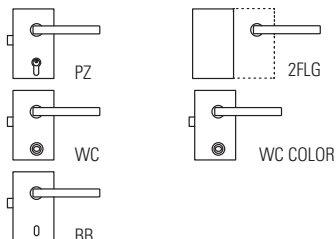

**V-780
VERTICAL FLAT**
▶ 84



**V-780 WC COLOR
VERTICAL FLAT**
▶ 86



**V-780 WC
VERTICAL FLAT**
▶ 88



**V-750 / MV-750
VERTICALE**
▶ 90



**V-770
SECUR**
▶ 116



**SERRATURE PICCOLE
PER PORTE BATTENTI**
**COMPACTED LOCKS
FOR SWING DOORS**
**KOMPAKTE SCHLÖSSER
FÜR DREH-TÜREN**

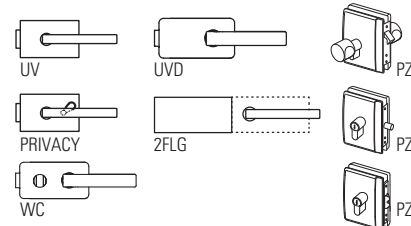

**V-900
I-LOCK**
▶ 68-71



**MV-900
I-LOCK**
▶ 72



**V-540
MINIMA FLAT**
▶ 74



**V-700
SQUARE**
▶ 116



**V-519 / V-520
MINIMA BATTUTA**
▶ 99



**SERRATURE
PER PORTE SCORREVOLI E LIBERE**
**LOCKS
FOR SLIDING DOORS AND FOR DOUBLE ACTION DOORS**
**SCHLÖSSER
FÜR SCHIEBETÜREN UND FÜR GANZGLASANLAGEN**

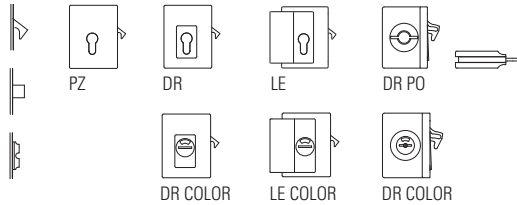

xme441

**V-744 / V-744 COLOR
V-745 / V-745 COLOR
V-746 / V-746 COLOR
ELEGANT LEVER**
▶ 92-93



**V-584 / V-584 COLOR
V-585 / V-585 COLOR
MINIMA 55 LEVER**
▶ 106-107



**V-734 / V-734 COLOR
V-735 / V-735 COLOR
V-736 / V-736 COLOR
ELEGANT DRAG**
▶ 94-95



**V-594 / V-594 COLOR
MINIMA DRAG**
▶ 108-109



**V-724 / V-725 / V-726
ELEGANT**
▶ 96



**V-574 / V-575
MINIMA 55 RIBASSATA**
▶ 110



**V-504 NC / V-505 / V-515
MINIMA**
▶ 98



**V-785 / V-785 COLOR
V-775 / V-775 COLOR
EASY LOCK**
▶ 112-113



**V-518
MINIMA BATTUTA**
▶ 99



V-404
▶ 115



**V-554 NC
V-557 BOTTE**
▶ 100



V-604 / V-407
▶ 117



**V-529 / V-530
CONTROSERRATURA**
▶ 101



X-133
▶ 207



**V-564 / V-564 COLOR
V-565 / V-565 COLOR
MINIMA 55**
▶ 104-105



X-030 C
▶ 206



**ACCESSORI
ACCESSORIES
ZUBEHÖRE**

C-06 C-02 C-06



**CONTROPIASTRE
STRIKE PLATES
SCHLIEBBLECHE**
▶ 138-140



**CILINDRI
CYLINDERS
ZYLINDER**
▶ 142-144



**CRICCHETTI
ROLLER BOLTS
TÜRSCHNÄPPER**
▶ 147-148



**CATENACCIOLI
LOCKING BOLT
FESTSTELLER**
▶ 146



X-317
▶ 208



**ACCESSORI
PER VETRINE
ACCESSORIES
FOR DISPLAY CABINETS
ZUBEHÖRE
FÜR SCHAUFENSTERAUSLAGE**

B-309
▶ 148



**CERNIERE VERTICALI
PER PORTE BATTENTI**
VERTICAL HINGES
VERTIKALE BÄNDER

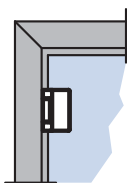

V-709 LIBRA
▶ 118



V-509 SLIM
▶ 118



V-809
▶ 118



V-701
▶ 120



V-909
▶ 119



V-729
▶ 121



**V-409
STILO**
▶ 119



**V-719
LIBRA**
▶ 122



P-08
CERNIERE TUTTA
ALTEZZA INCOLLAGGIO
▶ 124



P-09
CERNIERE
TUTTA ALTEZZA
▶ 125



**CERNIERE ALTO/BASSO
TOP/BOTTOM**
OBERE/UNTERE BÄNDER

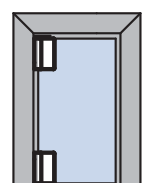

V-704 DX-SX
▶ 120



V-707 DX-SX
▶ 122



**V-107
SLIM**
▶ 122



**CERNIERE VERTICALI
PER STIPITI TEDESCHI**
VERTICAL HINGES FOR GERMAN FRAMES
3-TEILIGE BÄNDER DIN ZARGEN

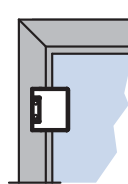

V-402
▶ 119



**V-702
ZETA**
▶ 121



**CERNIERE ORIZZONTALI
HORIZONTAL HINGES**
HORIZONTALE BÄNDER

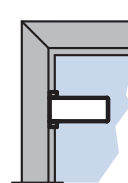

V-202
▶ 126



**V-403
FERRARI**
▶ 127



**CERNIERE ORIZZONTALI
PER STIPITI TEDESCHI**
**HORIZONTAL HINGES
FOR GERMAN FRAMES**
2-TEILIGE BÄNDER DIN ZARGEN



V-201
▶ 126



**V-401
FERRARI**
▶ 126



**V-102
ONE**
▶ 127



**CERNIERE VETRO/VETRO
 GLASS/GLASS HINGES
 GLAS/GLAS BÄNDER**

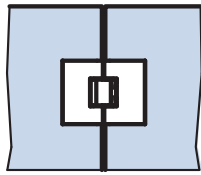

V-739
 ▶ 121



V-513
 SLIM
 ▶ 122



L-220
 ▶ 127



**CERNIERE OLEODINAMICHE
 HYDRAULIC HINGES
 HYDRAULISCHE BÄNDER**



V-808
 V-808-AS
 ▶ 130



V-816
 ▶ 130



V-808-R
 ▶ 131



V-816-R
 ▶ 131



V-807
 ▶ 133



**CERNIERE OLEODINAMICHE
 HYDRAULIC HINGES
 HYDRAULISCHE BÄNDER**

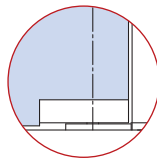

V-H1012 / V-H1013
 "OLLY"
 ▶ 136

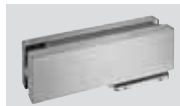

LAM-H1006
 LAM-H1008
 ▶ 135



LAM-H1007
 ▶ 135



**CERNIERE AUTOMATICHE
 AUTOMATIC HINGES
 AUTOMATISCHE BÄNDER**

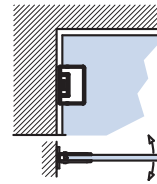

V-908
 V-908 AS
 ▶ 128-129



V-508
 V-508 AS
 ▶ 128-129



V-516
 ▶ 128



V-507
 ▶ 129



ANTIK
 ▶ 212



V-900 I-LOCK



V-900 PZ



Patent Pending

V-921
Maniglia / Handle / Griff



- Serratura I-Lock altamente compatta. Maniglie, cilindri e contropiastre da ordinare a parte.
- High compacted lock. Handles, cylinders and strike plates not included, to order separately.
- Hohes kompaktes Schloss. Griffe, Zylinder und Schließbleche nicht enthalten, separat zu bestellen

V-900 PZ



V-1762 Ratio
Maniglia / Handle / Griff

V-900 WC



V-1712 Morphos Light
Maniglia / Handle / Griff

V-900 PZ

€► E.01

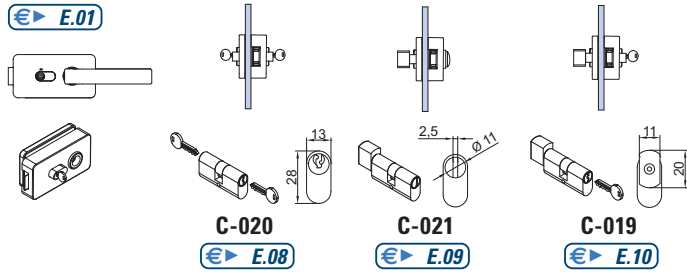

C-020
€► E.08

C-021
€► E.09

C-019
€► E.10

V-900 UV

€► E.02

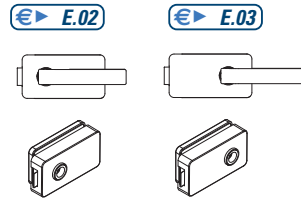

V-900 UVD

€► E.03

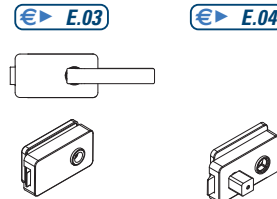

V-900 WC

€► E.04

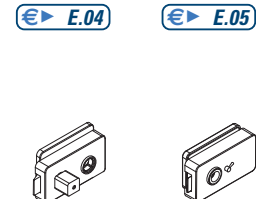

V-900 Privacy

€► E.05



LAVORAZIONE VETRO ALTERNATIVA
ALTERNATIVE GLASS PREPARATION
ALTERNATIVE GLASBEARBEITUNG

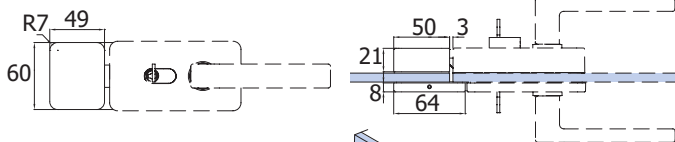
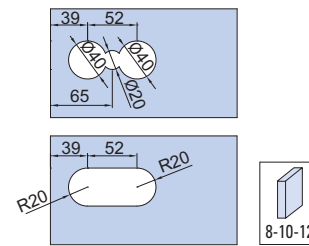
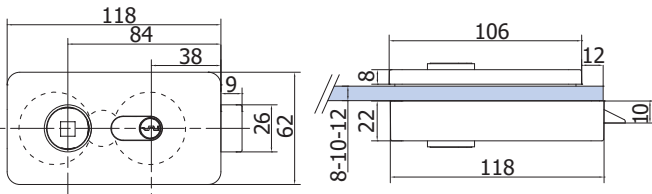

V-900 2FLG

- Controserratura
- Strike box
- Gegenkasten

€► E.07

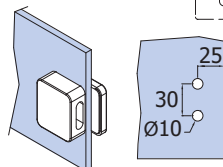

V-037



CP-01



V-931



V-704



V-709



V-809



- Cerniere
 - Hinges
 - Bänder
- 118

xme444 / xme409 / xme409d

CS
Cromo satinato
Satin chrome
Chrom matt

NS
Nickel satinato
Satin nickel
Ähnlich Edelstahl matt

CR
Cromo lucido
Polished chrome
Chrom glänzend

CP
Cromo perla
Chrome perla similar Alu
Chrom perla ähnlich Alu

NO
Nero opaco
Matt black
Schwarz matt

V-900 I-LOCK (AN / IX)

*nuove finiture
new finishes*



V-900 PZ (AN / IX)



V-921
Maniglia / Handle / Griff



- Maniglie, cilindri e contropiastre da ordinare a parte.
- Handles, cylinders and strike plates not included, to order separately.
- Griffe, Zylinder und Schließbleche nicht enthalten, separat zu bestellen.



V-1731 Elektra
Maniglia / Handle / Griff



V-101 L-Form 90°
Maniglia / Handle / Griff

V- 900 PZ (AN / IX) € E.13

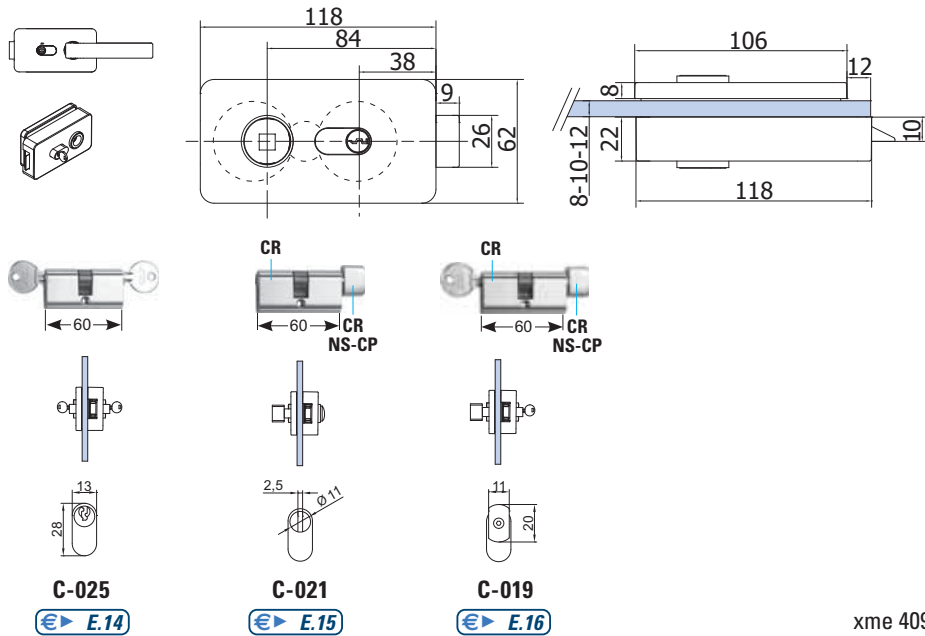

LAVORAZIONE VETRO ALTERNATIVA
ALTERNATIVE GLASS PREPARATION
ALTERNATIVE GLASBEARBEITUNG

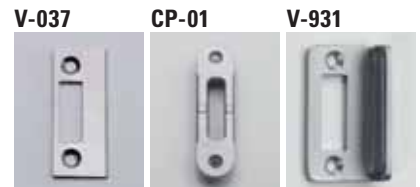
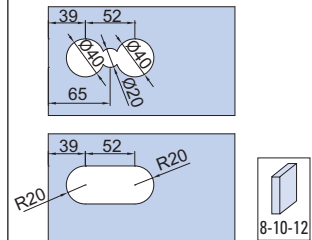

SERRATURE

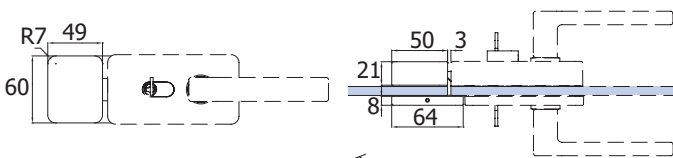

V-900 2FLG
• Controserratura
• Strike box
• Gegenkasten

€ E.18

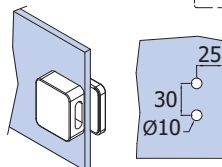

xme 409

xme 409d

nuove finiture
new finishes

AN
Alluminio anodizzato
Aluminium anodized
Aluminium Silberfarbig

IX
Acciaio inox satinato
Satin stainless steel
Edelstahl matt

MV-900 I-LOCK





SERRATURE

MV-900 PZ

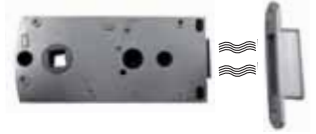

Patent Pending

- Serratura I-Lock altamente compatta. Maniglie, cilindri e contropiastre da ordinare a parte.
- High compacted lock. Handles, cylinders and strike plates not included, to order separately.
- Hohes Kompaktes Schloss. Griffe, Zylinder und Schließbleche nicht enthalten, separat zu bestellen



V-1731 Elektra
Maniglia / Handle / Griff

MV-900 UVD



V-1721 Preso
Maniglia / Handle / Griff

MV-900 WC



V-1685 Vola
Maniglia / Handle / Griff

MV-900 PZ
€► E.20

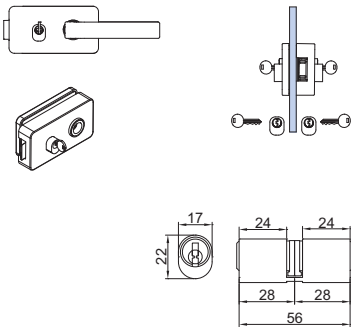

C-022
€► E.23

MV-900 UVD
€► E.21

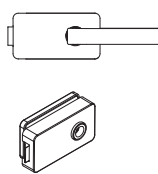

MV-900 WC
€► E.22

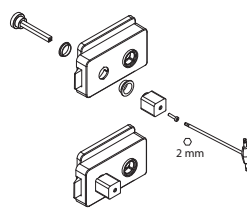

LAVORAZIONE VETRO ALTERNATIVA
ALTERNATIVE GLASS PREPARATION
ALTERNATIVE GLASBEARBEITUNG

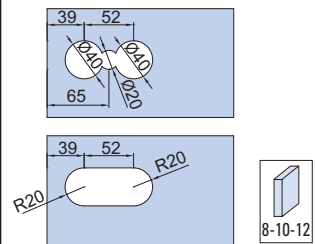

SERRATURE



- CP-012**
- Contropiastre magnetica inclusa
 - Magnetic strike plate included
 - Magnetisches schließblech inkl.

- Cerniere
- Hinges
- Bänder

V-704



V-709



V-809



xme044 / xme409 / xme409d

CS
Cromo satinato
Satin chrome
Chrom matt

NS
Nickel satinato
Satin nickel
Ähnlich Edelstahl matt

CR
Cromo lucido
Polished chrome
Chrom glänzend

CP
Cromo perla
Chrome perla similar Alu
Chrom perla ähnlich Alu

NO
Nero opaco
Matt black
Schwarz matt

V-540 MINIMA FLAT



V-540 UV



V-1731 Elektra
Maniglia / Handle / Griff

- Serratura MINIMA FLAT altamente compatta. Maniglie e contropiastra da ordinare a parte.
- High compacted lock. Handles, cylinders and strike plates not included, to order separately.
- Hohes kompaktes Schloss. Griffe, Zylinder und Schließbleche nicht enthalten, separat zu bestellen

V-540 UV



V-1611 Blade
Maniglia / Handle / Griff

V-540 Privacy



V-1712 Morphos Light
Maniglia / Handle / Griff

V-540 UV

€ E.25

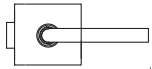

V-540 Privacy

€ E.26

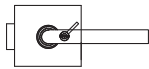

V-540 2FLG

€ E.27



V-540 UV

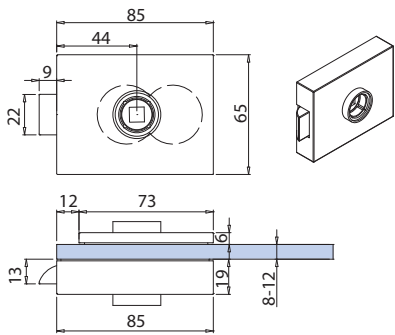

LAVORAZIONE VETRO
GLASS PREPARATION
GLASBEARBEITUNG

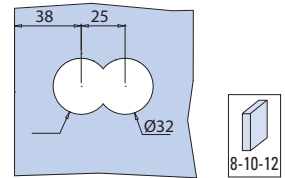

V-540 Privacy

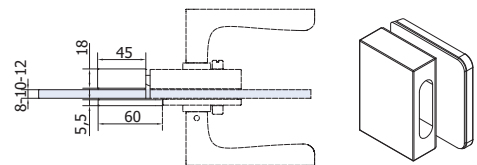
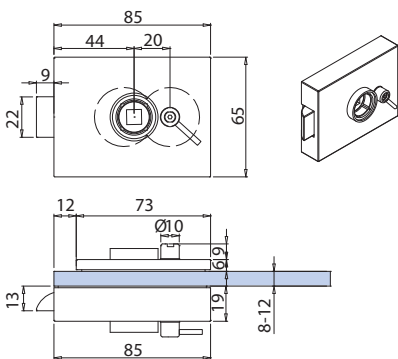

V-540 2FLG

- Controserratura
- Strike box
- Gegenkasten

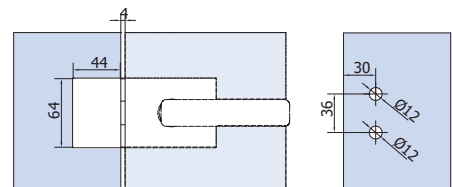

xme514a/xme519

CS Cromo satinato Satin chrome Chrom matt	NS Nickel satinato Satin nickel Ähnlich Edelstahl matt	CR Cromo lucido Polished chrome Chrom glänzend	CP Cromo perla Chrome perla similar Alu Chrom perla ähnlich Alu
---	--	--	---

V-230 BASIC ROUND



V-230 UV



V-1762 Ratio
Maniglia / Handle / Griff

- Maniglie, cilindri e contropiastre da ordinare a parte.
- Handles, cylinders and strike plates not included, to order separately.
- Griffe, Zylinder und Schließbleche nicht enthalten, separat zu bestellen.

V-230 PZ



V-921
Maniglia / Handle / Griff

V-230 UV



V-1751 Sole
Maniglia / Handle / Griff

V-230 UV

€ E.28

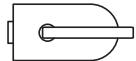

V-230 PZ

€ E.29

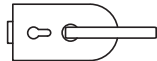

V-230 2FLG

€ E.30

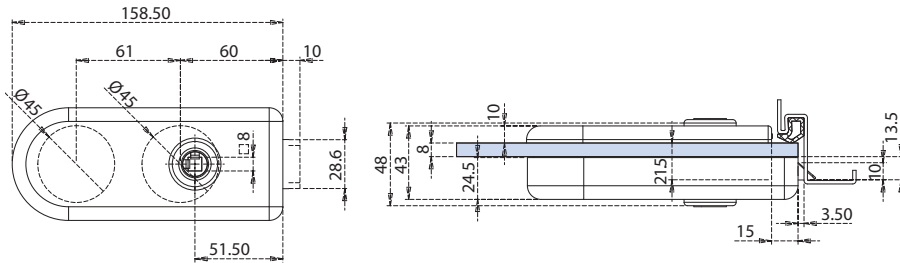
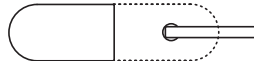

LAVORAZIONE VETRO
GLASS PREPARATION
GLASBEARBEITUNG

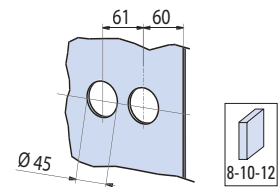

V-230 2FLG

- Controserratura
- Strike box
- Gegenkasten

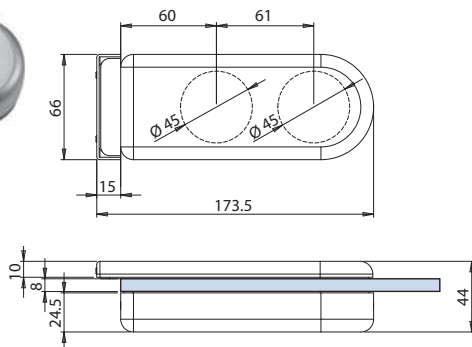

V-037



CP-01



V-704



V-709



V-809



- Cerniere
 - Hinges
 - Bänder
- 118

xme522

AN
Alluminio anodizzato
Aluminium anodized
Aluminium Silberfarbig

NS
Nickel satinato
Satin nickel
Ähnlich Edelstahl matt

V-730 BASIC SQUARE



SERRATURE

V-730 UV



V-1731 Elektra
Maniglia / Handle / Griff

- Maniglie, cilindri e contropiastre da ordinare a parte.
- Handles, cylinders and strike plates not included, to order separately.
- Griffe, Zylinder und Schließbleche nicht enthalten, separat zu bestellen.

V-730 PZ



V-921
Maniglia / Handle / Griff

V-730 UV



V-1712 Morphos Light
Maniglia / Handle / Griff

V-730 UV

€▶ E.32



V-730 PZ

€▶ E.33

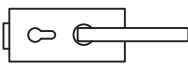

V-730 2FLG

€▶ E.34

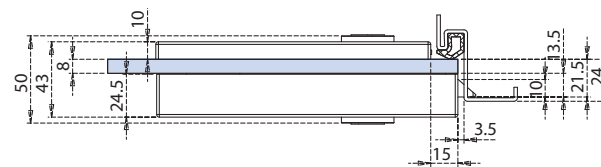
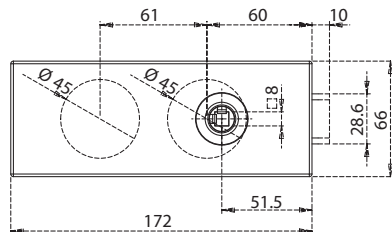

LAVORAZIONE VETRO
GLASS PREPARATION
GLASBEARBEITUNG

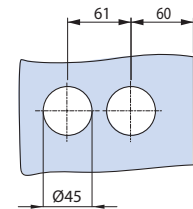

V-730 2FLG

- Controserratura
- Strike box
- Gegenkasten

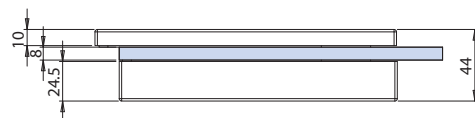
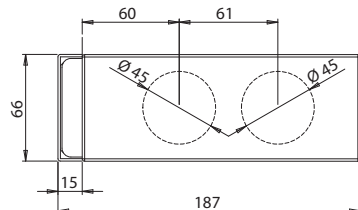

V-037



CP-01



V-704



V-709



V-809



- Cerniere
 - Hinges
 - Bänder
- ▶ 118

xme523

AN
Alluminio anodizzato
Aluminium anodized
Aluminium Silberfarbig

NS
Nickel satinato
Satin nickel
Ähnlich Edelstahl matt

V-200 ECO / MV-200 ECO

NUOVA SERRATURA SILENZIOSA PER PORTE IN VETRO / NEW SILENT LOCK FOR GLASS DOOR / NEUES GERÄUSCHARMES GLASTÜRSCHLOSS

H I G H
 Q U A L I T Y
 M A D E I N I T A L Y



SERRATURE



- Regolazione forza molla serratura.
- Adjustment lock's spring.
- Justierung der Schlossfeder.



- Scrocco serratura in metallo con inserto in plastica per maggiore silenziosità in chiusura al contatto con la contropiastra.
- The metal latch is made with a plastic insert that insures strength and quietness in contact with striker.
- Die Flüsterfalle aus Metall mit Kunststoffeinsatz garantiert einen kraftvollen und geräuscharmen Kontakt mit dem Schließblech.



- Regolazione forza molla scrocco.
- Adjustment latch spring.
- Justierung der Fallenspannkraft.



- Quadro maniglia con molle per una maggiore stabilità della maniglia.
- The double clamping nut is holding the handle steady.
- Doppelte Klemmnuss gibt dem Griff stabilen Halt.

V-200 ECO UV



V-101 L-Form 90
Maniglia / Handle / Griff

MV-200 ECO

- Versione magnetica
- Magnetic version
- Mit magnetischem Schließvorgang



V-200 ECO UV



V-1671 Le Mans
Maniglia / Handle / Griff

V-200 ECO UV



V-110-inox U-form
Maniglia / Handle / Griff

V-200 ECO UV

MV-200 ECO UV

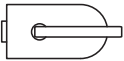

V-200 ECO PZ

MV-200 ECO PZ

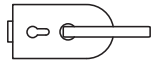

V-200 ECO BB

MV-200 ECO BB

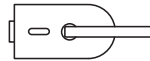

V-200 ECO WC

MV-200 ECO WC

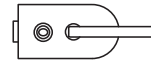

V-200 ECO 2FLG

MV-200 ECO 2FLG

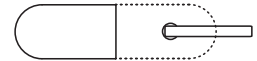

V-200 ECO P

MV-200 ECO P

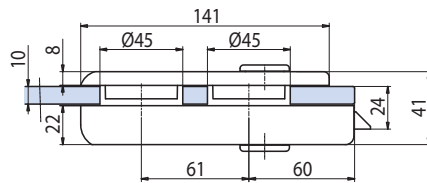
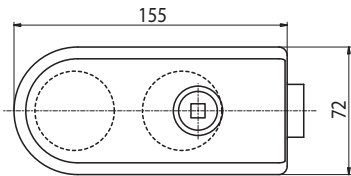
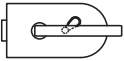

V-200 ECO 2FLG

MV-200 ECO 2FLG

- Controserratura
- Strike box
- Gegenkasten

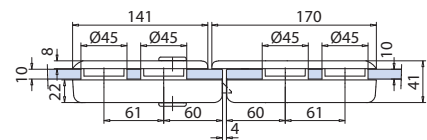
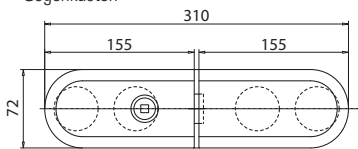

LAVORAZIONE VETRO
GLASS PREPARATION
GLASBEARBEITUNG

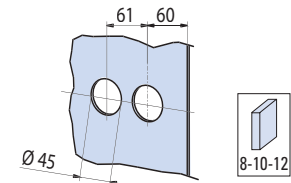

V-200 ECO

€ E.36 → € E.40

MV-200 ECO

€ E.41 → € E.45

- Cerniere
 - Hinges
 - Bänder
- 118

V-709



V-809



xla187

CS
Cromo satinato
Satin chrome
Chrom matt

NS
Nickel satinato
Satin nickel
Ähnlich Edelstahl matt

CR
Cromo lucido
Polished chrome
Chrom glänzend

CP
Cromo perla
Chrome perla similar Alu
Chrom perla ähnlich Alu

OL
Ottone lucido
Polished brass
Messing poliert

AN
Alluminio anodizzato
Aluminium anodized
Aluminium Silberfarbig

IX
Acciaio inox satinato
Satin stainless steel
Edelstahl matt

V-720 LIBRA / MV-720 LIBRA 

V-720 LIBRA ECO / MV-720 LIBRA ECO 



SERRATURE

V-720 UV



V-1611 Blade
Maniglia / Handle / Griff

MV-720

- Versione magnetica
- Magnetic version
- Mit magnetischem Schließvorgang



V-720 PZ



V-1711 Morphos
Maniglia / Handle / Griff

V-720 UV



V-1721 Preso
Maniglia / Handle / Griff

V-720 UV

MV-720 UV

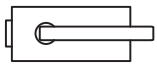

V-720 PZ

MV-720 PZ

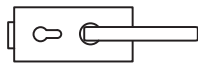

V-720 BB

MV-720 BB

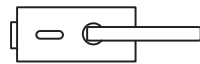

V-720 WC

MV-720 WC

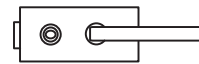

V-720 P

MV-720 P

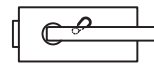

V-720 2FLG

MV-720 2FLG

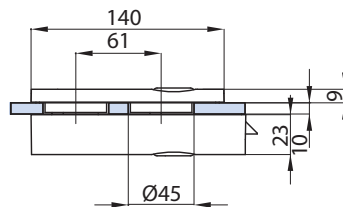
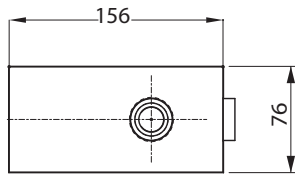
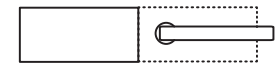

V-720 2FLG
MV-720 2FLG

- Controserratura
- Strike box
- Gegenkasten

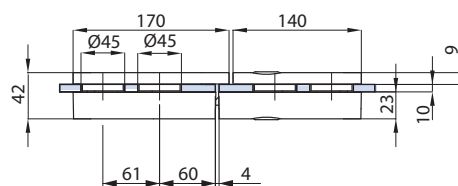
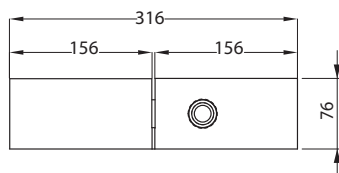

LAVORAZIONE VETRO
GLASS PREPARATION
GLASBEARBEITUNG

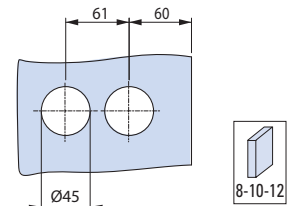

SERRATURE

ECO VERSION

V-720 **E.46** → **E.50**

MV-720 **E.51** → **E.55**

V-720 ECO **E.56** → **E.60**

MV-720 ECO **E.61** → **E.65**

- Cerniere
 - Hinges
 - Bänder
- 118

V-704



V-809



xme047

CS
Cromo satinato
Satin chrome
Chrom matt

NS
Nickel satinato
Satin nickel
Ähnlich Edelstahl matt

CR
Cromo lucido
Polished chrome
Chrom glänzend

CP
Cromo perla
Chrome perla similar Alu
Chrom perla ähnlich Alu

OL
Ottone lucido
Polished brass
Messing poliert

NO
Nero opaco
Matt black
Schwarz matt

V-780 FLAT



SERRATURE

V-780 PZ



V-1762 Ratio
Maniglia / Handle / Griff

- Serratura Vertical Flat con foro per cilindro ovale. Maniglie, cilindri e contropiastre da ordinare a parte.
- Vertical Flat lock for oval cylinder. Handles, cylinders and strike plates not included, to order separately.
- Vertikal Flat Schloss, mit Lochung für ovalen Zylinder. Griffe, Zylinder und Schließbleche nicht enthalten, separat zu bestellen.

V-780 2FLG



V-780 PZ-L
(sinistra/left/links)

e▶ E.66



PZ SX

A SINISTRA/LEFT/LINKS

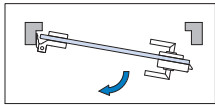

C SINISTRA/LEFT/LINKS

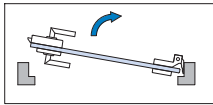

V-780 PZ-R
(destra/right/rechts)

e▶ E.66



PZ DX

B DESTRA/RIGHT/RECHTS

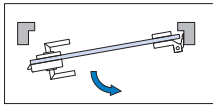

D DESTRA/RIGHT/RECHTS

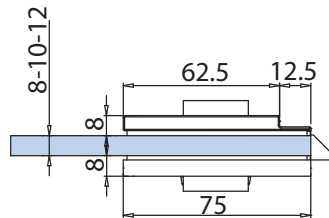
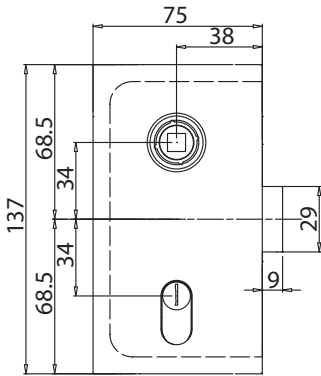
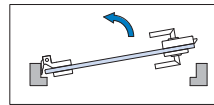

LAVORAZIONE VETRO
GLASS PREPARATION
GLASBEARBEITUNG

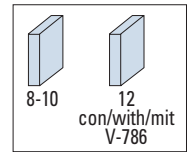
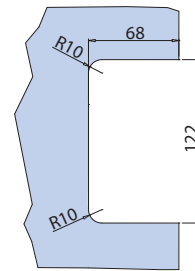

V-786

- Spessore per vetro 12 mm
- Spacer for glass thickness 12 mm
- Distanzscheibe für Glasdicke 12 mm

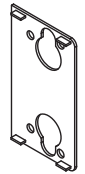

CP-01

V-709

V-701



xme 513

SERRATURE

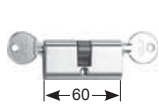

C-020

e▶ E.67

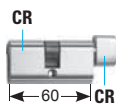

C-021

e▶ E.68

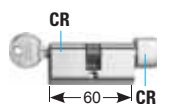

C-019

e▶ E.69



V-780 2FLG

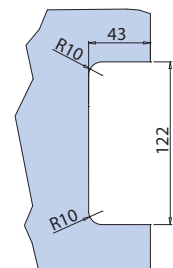
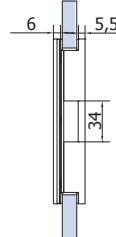
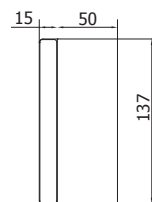

CS
Cromo satinato
Satin chrome
Chrom matt

NS
Nickel satinato
Satin nickel
Ähnlich Edelstahl matt

CP
Cromo perla
Chrome perla similar Alu
Chrom perla ähnlich Alu

GR
Grezzo
Raw
Roh

V-780 WC COLOR



SERRATURE

V-780 WC COLOR



- Serratura Vertical Flat con nottolino WC e indicatore colorato. Maniglie e contropiastre da ordinare a parte.
- Vertical Flat lock with WC thumb turn and coloured indicator. Handles and strike plates not included, to order separately.
- Vertikal Flat Schloss mit WC Riegelknopf und Farbanzeige. Griffe und Schließbleche nicht enthalten, separat zu bestellen.



V-780 WC COLOR-L **E.71**
(sinistra/left/links)



A SINISTRA/LEFT/LINKS

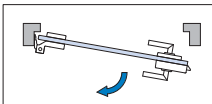

C SINISTRA/LEFT/LINKS

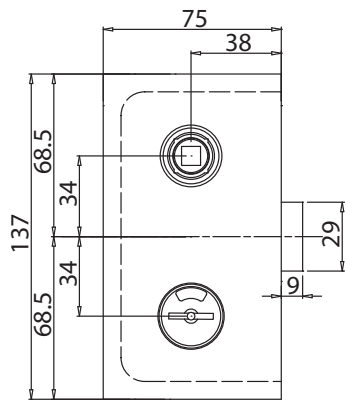
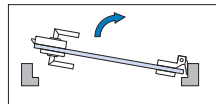

V-780 WC COLOR-R **E.71**
(destra/right/rechts)

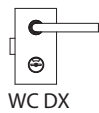

B DESTRA/RIGHT/RECHTS

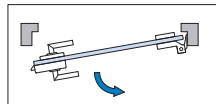

D DESTRA/RIGHT/RECHTS

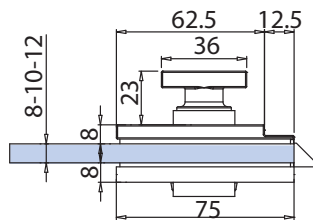
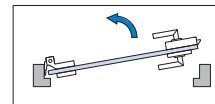

LAVORAZIONE VETRO
GLASS PREPARATION
GLASBEARBEITUNG

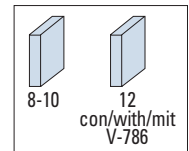
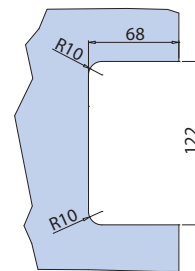

V-786

- Spessore per vetro 12 mm
- Spacer for glass thickness 12 mm
- Distanzscheibe für Glasdicke 12 mm

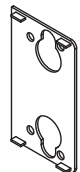

CP-01



V-709



V-809



V-704



V-701



V-780 2FLG

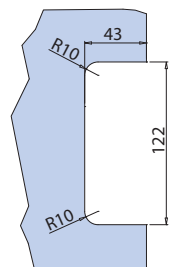
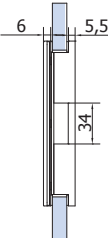
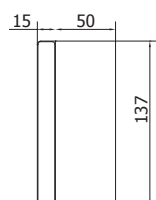

CS
Cromo satinato
Satin chrome
Chrom matt

NS
Nickel satinato
Satin nickel
Ähnlich Edelstahl matt

CP
Cromo perla
Chrome perla similar Alu
Chrom perla ähnlich Alu

xme 513

SERRATURE

V-780 WC



SERRATURE

V-780 WC



V-921
Maniglia / Handle / Griff

- Serratura Vertical Flat con nottolino WC. Maniglie e contropiastre da ordinare a parte.
- Vertical Flat lock with WC thumb turn. Handles and strike plates not included, to order separately.
- Vertikal Flat Schloss mit WC Riegelknopf. Griffe und Schließbleche nicht enthalten, separat zu bestellen.



V-780 WC-L e▶ E.70
(sinistra/left/links)

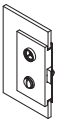

A SINISTRA/LEFT/LINKS

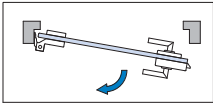

C SINISTRA/LEFT/LINKS

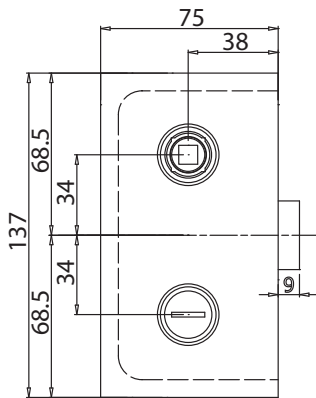
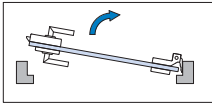

V-780 WC-R e▶ E.70
(destra/right/rechts)

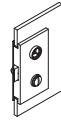

B DESTRA/RIGHT/RECHTS

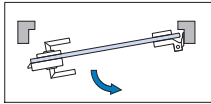

D DESTRA/RIGHT/RECHTS

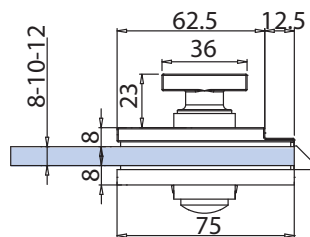
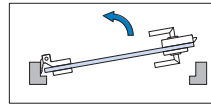

LAVORAZIONE VETRO
GLASS PREPARATION
GLASBEARBEITUNG

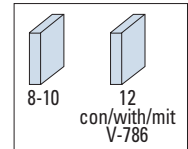
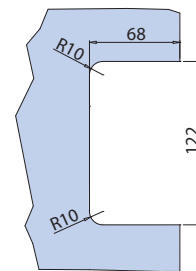

V-786 e▶ E.73

- Spessore per vetro 12 mm
- Spacer for glass thickness 12 mm
- Distanzscheibe für Glasdicke 12 mm

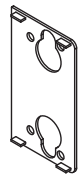

CP-01



V-709



V-809



V-704



V-701



V-780 2FLG

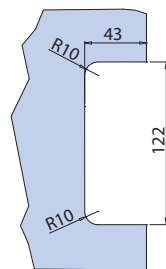
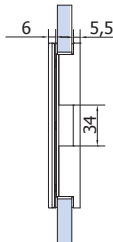
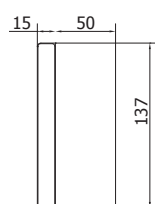

CS
Cromo satinato
Satin chrome
Chrom matt

NS
Nickel satinato
Satin nickel
Ähnlich Edelstahl matt

CP
Cromo perla
Chrome perla similar Alu
Chrom perla ähnlich Alu

xme 513

SERRATURE

V-750 VERTICALE / MV-750 PZ / WC / 2FLG 

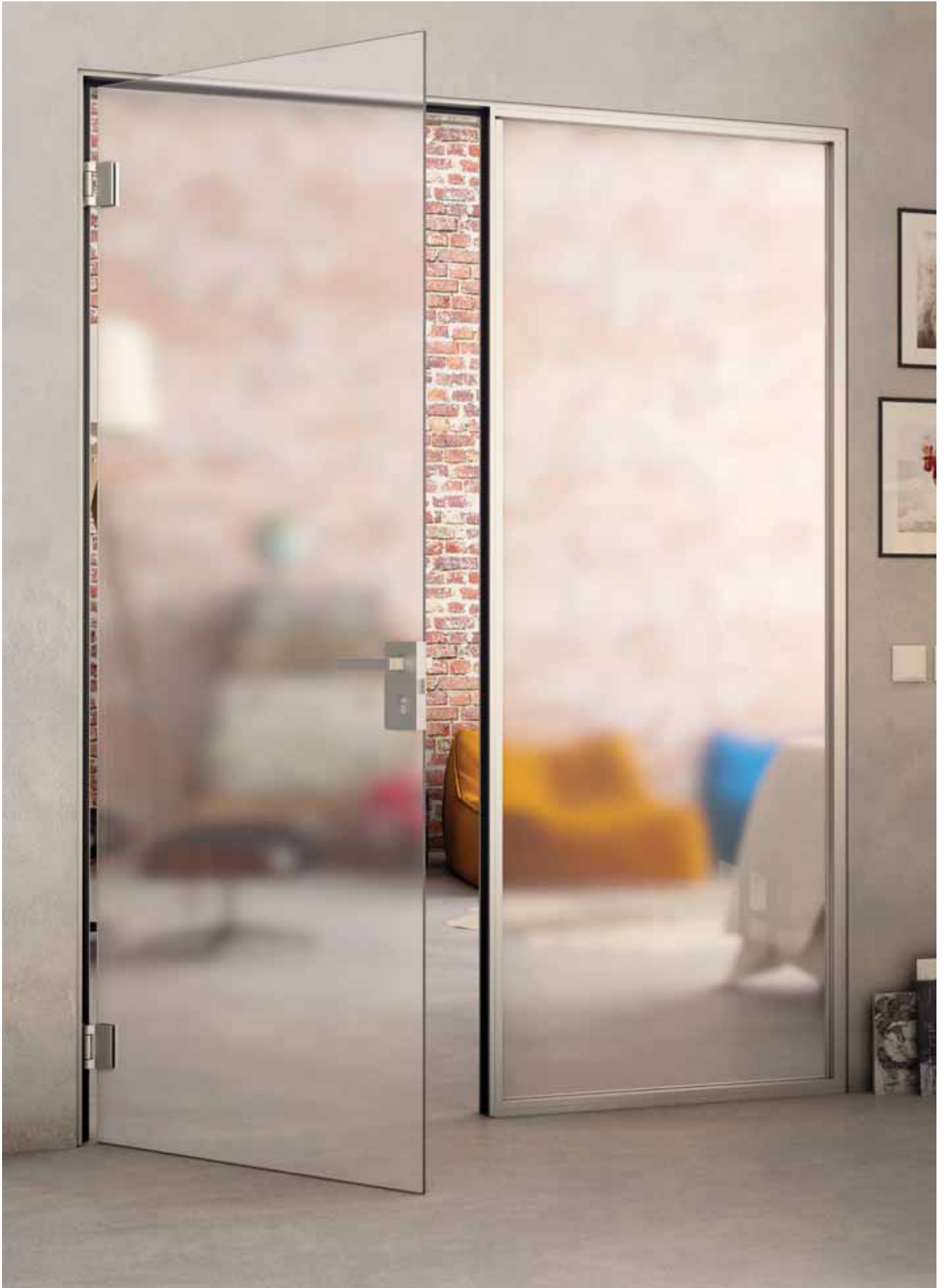

SERRATURE

V-750 PZ



V-1711 Morphos
Maniglia / Handle / Griff

MV-750 PZ / WC / 2FLG

- Versione magnetica
- Magnetic version
- Mit magnetischem Schließvorgang



V-750 WC COL



V-1801 Tecno
Maniglia / Handle / Griff



V-921
Maniglia / Handle / Griff

V-750 WC



Daytona V-140
Maniglia / Handle / Griff

V-750 BB



Blade V-1611
Maniglia / Handle / Griff

V-750 PZ-L

MV-750 PZ-L

sinistra / left / Links

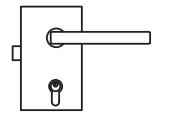

V-750 PZ-R

MV-750 PZ-R

destra / right / Rechts

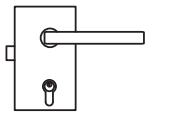

V-750 BB-L

MV-750 BB-L

sinistra / left / Links

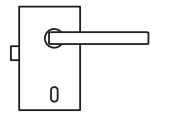

V-750 BB-R

MV-750 BB-R

destra / right / Rechts

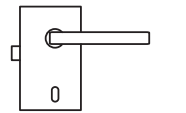

V-750 WC / V-750 WC COL

MV-750 WC / MV-750 WC COL

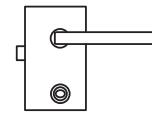

V-750 2FLG

MV-750 2FLG

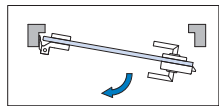
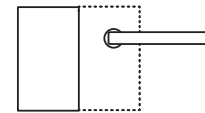

sinistra / left / Links

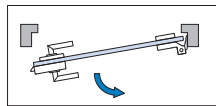

destra / right / Rechts

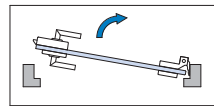

sinistra / left / Links

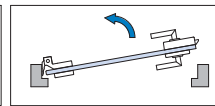

destra / right / Rechts

V-750

€ E.75 → € E.79

MV-750

€ E.82 → € E.85.1

V-750 / MV-750

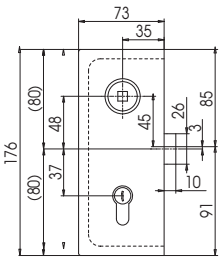

V-750 2FLG / MV-750 2FLG

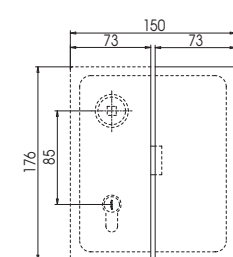

V-750 2FLG

- Controserratura verticale
- Vertical strike box
- Vertikal Gegenkasten



V-750 ELET PZ L

V-750 ELET PZ R

€ E.80



LAVORAZIONE VETRO
GLASS PREPARATION
GLASBEARBEITUNG

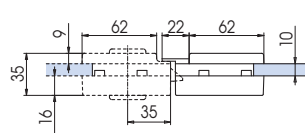
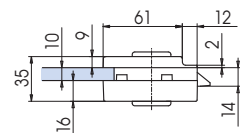
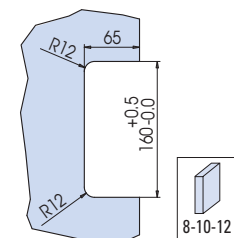

- Cerniere
 - Hinges
 - Bänder
- ▶ 118

V-704



V-709



V-809



xla219

CS
Cromo satinato
Satin chrome
Chrom matt

NS
Nickel satinato
Satin nickel
Ähnlich Edelstahl matt

CR
Cromo lucido
Polished chrome
Chrom glänzend

CP
Cromo perla
Chrome perla similar Alu
Chrom perla ähnlich Alu

OL
Ottone lucido
Polished brass
Messing poliert

ELEGANT LEVER

V-744 PZ



Patent Pending



- Serrature Elegant con gancio per scorrevole, chiavistello tondo e scrocco ad olivetta. Impugnatura Leva incorporata. Cilindri e contropiastre da ordinare a parte.
- Locks Elegant with Hook for sliding doors, with rounded dead bolt or with double bevelled latch. Lever handle incorporated. Cylinders and strike plates not included, to order separately.
- Elegant Schlösser mit Hakenriegel für Schiebetüren, Mittelschloss mit Bolzen oder mit doppel schrägkantiger Falle. Griff angebaut. Zylinder und Schließbleche nicht enthalten, separat zu bestelle

V-744 PZ €►E.118

V-745 PZ €►E.119

V-746 PZ €►E.120



- Controserrature
- Strike boxes
- Gegenkästen

C-014

€►E.124

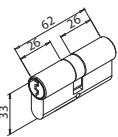

C-013

€►E.125

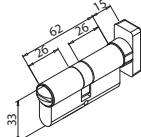

C-08-Q

€►E.126

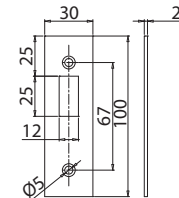
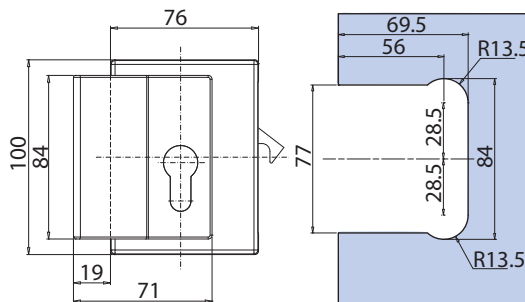
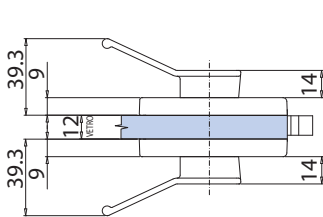
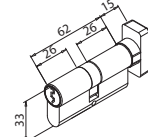

V-022

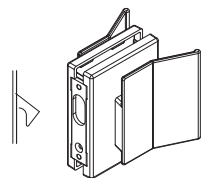

V-744 2FLG
€►E.121

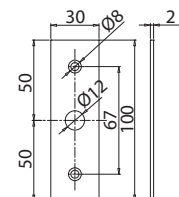

V-023

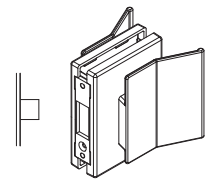

V-745 2FLG
€►E.122

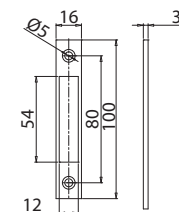

V-002

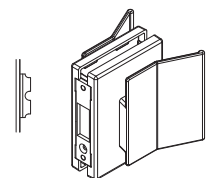

V-746 2FLG
€►E.123

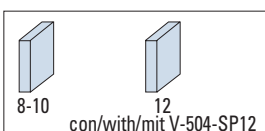

fb049-a-gr / fb049

CS
Cromo satinato
Satin chrome
Chrom matt

NS
Nickel satinato
Satın nickel
Ähnlich Edelstahl matt

CR
Cromo lucido
Polished chrome
Chrom glänzend

CP
Cromo perla
Chrome perla similar Alu
Chrom perla ähnlich Alu

SERRATURE

ELEGANT LEVER COLOR

V-744 COLOR



Patent Pending



- Serrature Elegant Color con gancio per scorrevole, chiavistello tondo e scrocco ad olivetta. Impugnatura Leva incorporata.
- Locks Elegant Color with Hook for sliding doors, with rounded dead bolt or with double bevelled latch. Lever handle incorporated.
- Elegant Color Schlösser mit Hakenriegel für Schiebetüren, Mittelschloss mit Bolzen oder mit doppel schrägkantiger Falle. Griff angebaut.

V-744 COLOR €► E.131

V-745 COLOR €► E.132

V-746 COLOR €► E.133



- Controserrature
- Strike boxes
- Gegenkästen

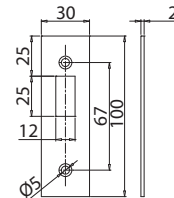
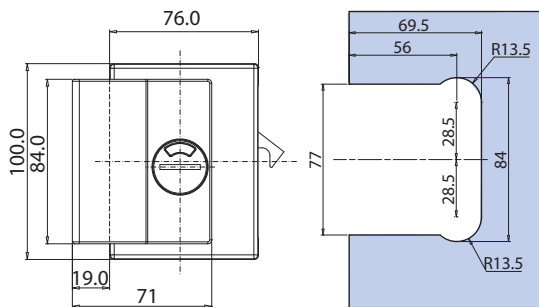
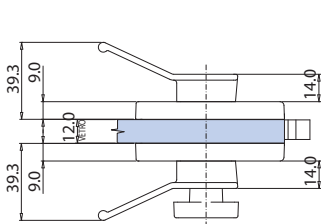

V-022

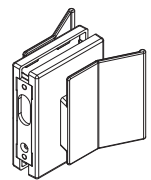

V-744 2FLG
€► E.134

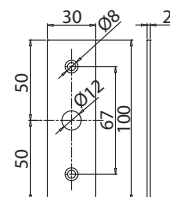

V-023

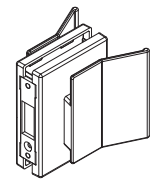

V-745 2FLG
€► E.135

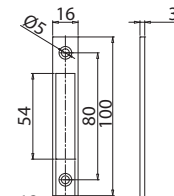

V-002

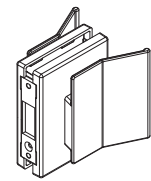

V-746 2FLG
€► E.136

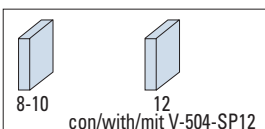

- | | | | |
|---|--|--|---|
| CS
Cromo satinato
Satin chrome
Chrom matt | NS
Nickel satinato
Satin nickel
Ähnlich Edelstahl matt | CR
Cromo lucido
Polished chrome
Chrom glänzend | CP
Cromo perla
Chrome perla similar Alu
Chrom perla ähnlich Alu |
|---|--|--|---|

fb049-a-gr / fb049

ELEGANT DRAG

V-734 PZ



Patent Pending



- Serrature Elegant con gancio per scorrevole, chiavistello tondo e scrocco ad olivetta. Cilindri e contropiastre da ordinare a parte.
- Locks Elegant with Hook for sliding doors, with rounded dead bolt or with double bevelled latch. Cylinders and strike plates not included, to order separately.
- Elegant Schlösser mit Hakenriegel für Schiebetüren, Mittelschloss mit Bolzen oder mit doppel schrägkantiger Falle. Zylinder und Schließbleche nicht enthalten, separat zu bestelle

V-734 PZ €►E.141

V-735 PZ €►E.142

V-736 PZ €►E.143



- Controserrature
- Strike boxes
- Gegenkästen

C-014
€►E.147

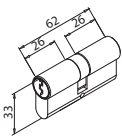

C-013
€►E.148

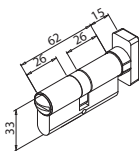

C-08-Q
€►E.149

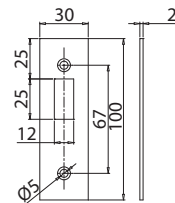
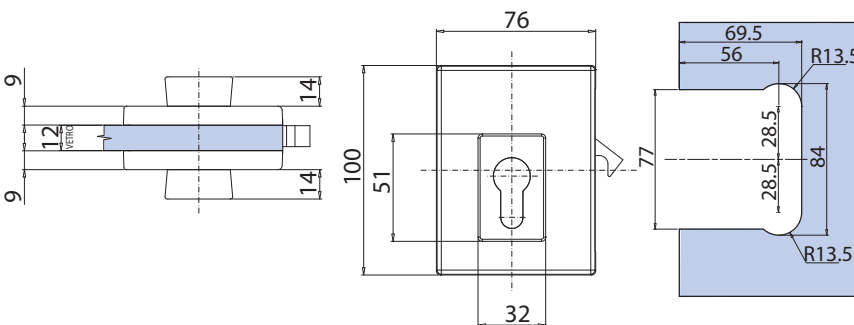
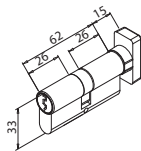

V-022

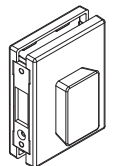

V-734 2FLG
€►E.144

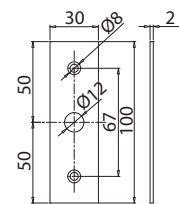

V-023

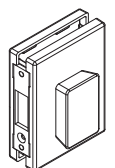

V-735 2FLG
€►E.145

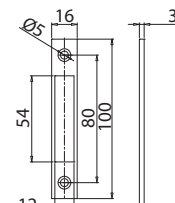

V-002

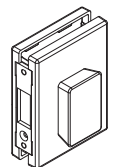

V-736 2FLG
€►E.146

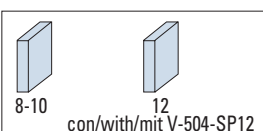

fb049-a-gr / fb049

CS
Cromo satinato
Satin chrome
Chrom matt

NS
Nickel satinato
Satın nickel
Ähnlich Edelstahl matt

CR
Cromo lucido
Polished chrome
Chrom glänzend

CP
Cromo perla
Chrome perla similar Alu
Chrom perla ähnlich Alu

ELEGANT DRAG COLOR

V-734 COLOR



Patent Pending



- Serrature Elegant Drag Color con gancio per scorrevole, chiavistello tondo e scrocco ad olivetta. Maniglia di trascinamento incorporata.
- Locks Elegant Drag Color with Hook for sliding doors, with rounded dead bolt or with double bevelled latch. Dragging handle incorporated.
- Elegant Drag Color Drag Schlösser mit Hakenriegel für Schiebetüren, Mittelschloss mit Bolzen oder mit doppel schrägkantiger Falle. Stirngriff angebaut.

V-734 COLOR €► E.154

V-735 COLOR €► E.155

V-736 COLOR €► E.156



- Controserrature
- Strike boxes
- Gegenkästen

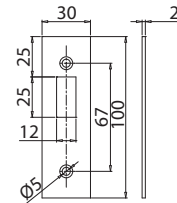
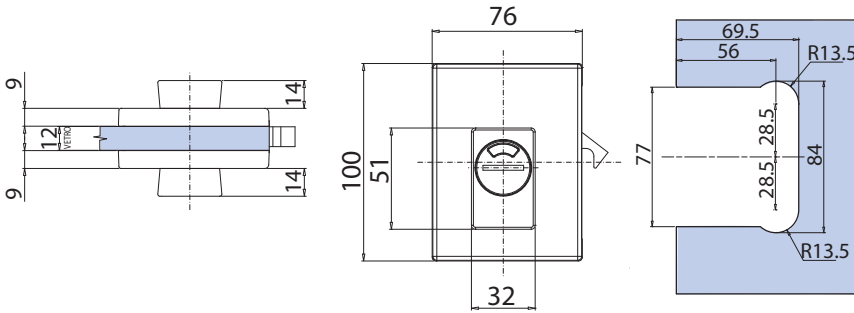

V-022

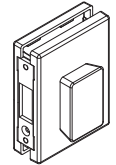

V-734 2FLG
€► E.157

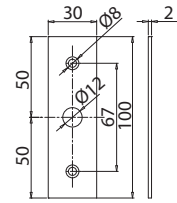

V-023

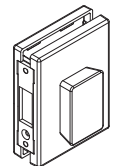

V-735 2FLG
€► E.158

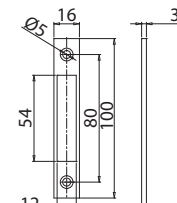

V-002

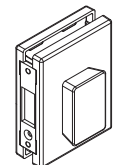

V-736 2FLG
€► E.159

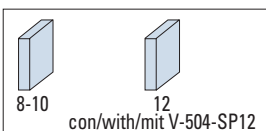

- | | | | |
|---|--|--|---|
| CS
Cromo satinato
Satin chrome
Chrom matt | NS
Nickel satinato
Satin nickel
Ähnlich Edelstahl matt | CR
Cromo lucido
Polished chrome
Chrom glänzend | CP
Cromo perla
Chrome perla similar Alu
Chrom perla ähnlich Alu |
|---|--|--|---|

fb049-a-gr / fb049

SERRATURE

ELEGANT

V-724 PZ



Patent Pending



- Serrature Elegant con gancio per scorrevole, chiavistello tondo e scrocco ad olivetta. Cilindri e contropiastre da ordinare a parte.
- Locks Elegant with Hook for sliding doors, with rounded dead bolt or with double bevelled latch. Cylinders and strike plates not included, to order separately.
- Elegant Schlösser mit Hakenriegel für Schiebetüren, Mittelschloss mit Bolzen oder mit doppel schrägkantiger Falle. Zylinder und Schließbleche nicht enthalten, separat zu bestellen

V-724 PZ € E.105

V-725 PZ € E.106

V-726 PZ € E.107



- Controserrature
- Strike boxes
- Gegenkästen

C-018
€ E.112

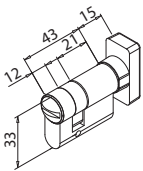

C-06
€ E.111

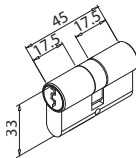

C-016
€ E.113

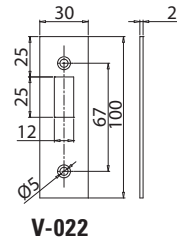
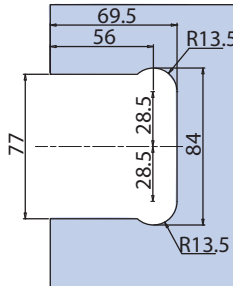
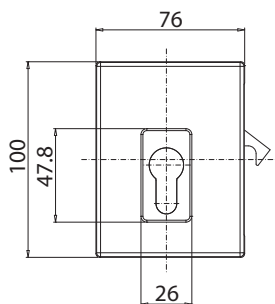
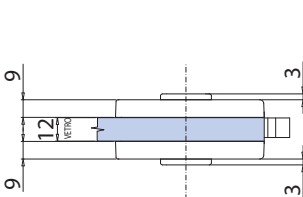
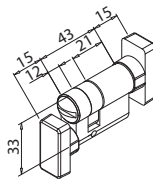

V-022

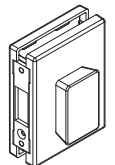

V-724 2FLG
€ E.108

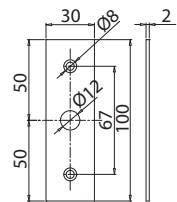

V-023

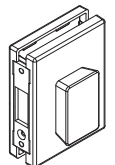

V-725 2FLG
€ E.109

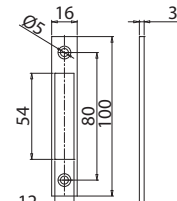

V-002

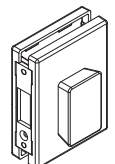

V-726 2FLG
€ E.110

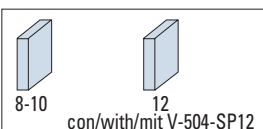

CS
Cromo satinato
Satin chrome
Chrom matt

NS
Nickel satinato
Satin nickel
Ähnlich Edelstahl matt

CR
Cromo lucido
Polished chrome
Chrom glänzend

CP
Cromo perla
Chrome perla similar Alu
Chrom perla ähnlich Alu

fb049-a-gr / fb049



SERRATURE

V-504 NC / V-505 / V-515 MINIMA

V-504 NC



- Serrature Minima con gancio per scorrevole, chiavistello tondo e scrocco ad olivetta. Cilindri e contropiastre da ordinare a parte.
- Locks Minima with Hook for sliding doors, with rounded dead bolt or with double bevelled latch. Cylinders and strike plates not included, to order separately.
- Minima Schlösser mit Hakenriegel für Schiebetüren, Mittelschloss mit Bolzen oder mit doppel schrägkantiger Falle. Zylinder und Schließbleche nicht enthalten, separat zu bestellen

V-504 NC €►E.164

V-505 €►E.165

V-515 €►E.166



- Controserrature
- Strike boxes
- Gegenkästen

SERRATURE

V-504 NC

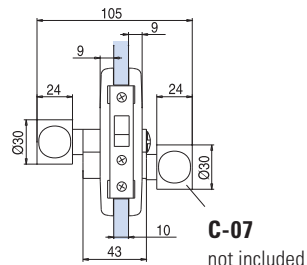
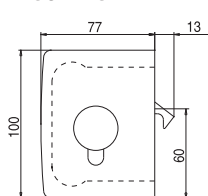

C-07
not included

V-505

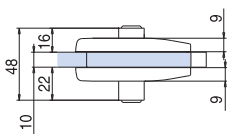
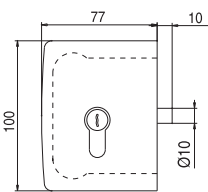

V-515

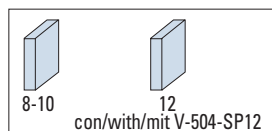
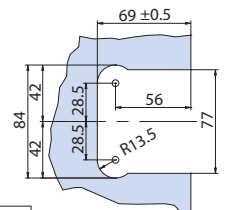
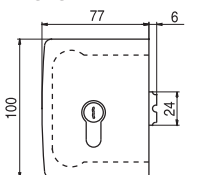

C-07

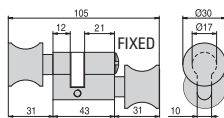

C-06

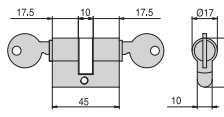

C-05

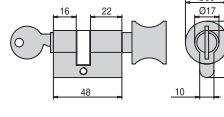

C-03

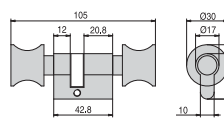

C-01

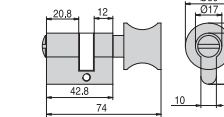

C-02

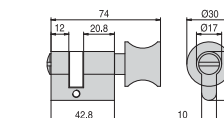

€►E.311 → €►E.317

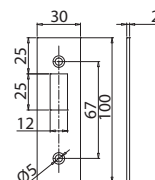

V-022

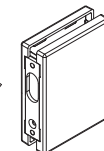

V-504 2FLG
€►E.167

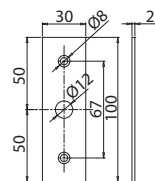

V-023

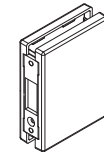

V-505 2FLG
€►E.168

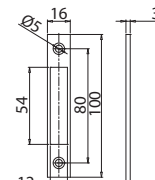

V-002

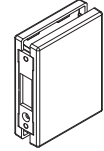

V-515 2FLG
€►E.169

CS
Cromo satinato
Satin chrome
Chrom matt

NS
Nickel satinato
Satin nickel
Ähnlich Edelstahl matt

CR
Cromo lucido
Polished chrome
Chrom glänzend

CP
Cromo perla
Chrome perla similar Alu
Chrom perla ähnlich Alu

OL
Ottone lucido
Polished brass
Messing poliert

NO
Nero opaco
Matt black
Schwarz matt

V-518 / V-519 / V-520 MINIMA BATTUTA

SERRATURA CON BATTUTA PER PORTE A BATTENTE / LOCKS FOR REBATED DOORS / SCHLOSS FÜR TÜREN MIT ANSCHLAG



V-518 DX/SX

€▶E.176

- Serratura MINIMA con gancio con pomolo e cilindro C-07 e battuta per porte scorrevoli a battente.
- MINIMA lock and cylinder C-07 with lock for glass sliding door with rebate for rebated doors.
- MINIMA Hakenschloss für Anschlag mit zyl C-07 inkl.

V-519 DX/SX

€▶E.178

- Serratura MINIMA con chiavistello tondo con battuta per porte a battente.
- MINIMA deadlock for cylinder (pz) with rebate for rebated doors.
- MINIMA pz Schloss für Anschlag.

V-520 DX/SX

€▶E.180

- Serratura MINIMA con olivetta con battuta per porte a battente
- MINIMA lock double bevelled latch with rebate for rebated doors
- MINIMA pz Schloss für Anschlag.

V-518

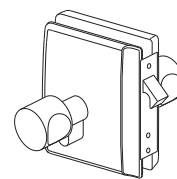
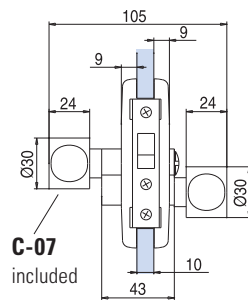
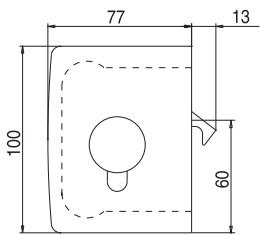

V-518 DX
destra / right / Rechts

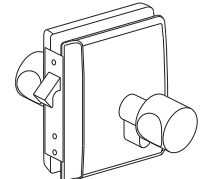

V-518 SX
sinistra / left / Links

V-519

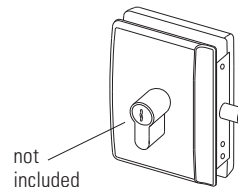
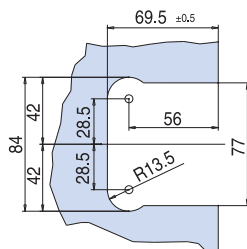
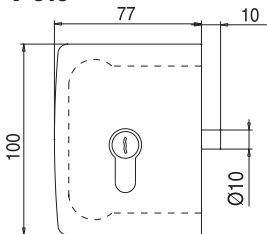

V-519 DX
destra / right / Rechts

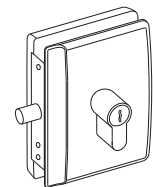

V-519 SX
sinistra / left / Links

V-520

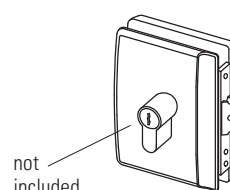
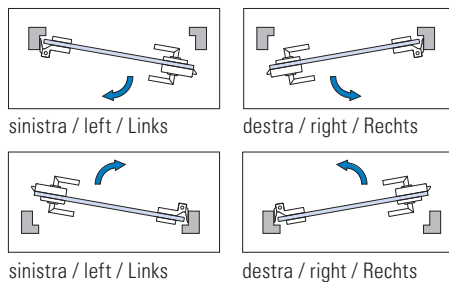
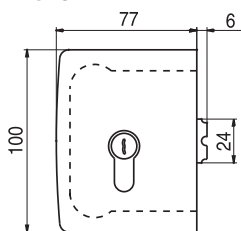

V-520 DX
destra / right / Rechts

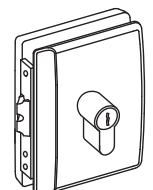

V-520 SX
sinistra / left / Links

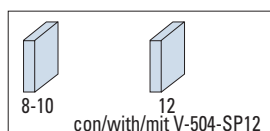

CS
Cromo satinato
Satin chrome
Chrom matt

NS
Nickel satinato
Satin nickel
Ähnlich Edelstahl matt

CR
Cromo lucido
Polished chrome
Chrom glänzend

CP
Cromo perla
Chrome perla similar Alu
Chrom perla ähnlich Alu

V-554 NC / V-557 BOTTE

V-554 NC



- Serrature Botte con gancio per scorrevole, chiavistello tondo e scrocco ad olivetta. Cilindri e contropiastre da ordinare a parte.
- Locks Botte with Hook for sliding doors, with rounded dead bolt or with double bevelled latch. Cylinders and strike plates not included, to order separately.
- Botte Schlösser mit Hakenriegel für Schiebetüren, Mittelschloss mit Bolzen oder mit doppel schrägkantiger Falle. Zylinder und Schließbleche nicht enthalten, separat zu bestellen.

V-554 NC €►E.183

V-557 €►E.184

V-555 €►E.185



- Controserrature
- Strike boxes
- Gegenkästen

SERRATURE

V-554 NC

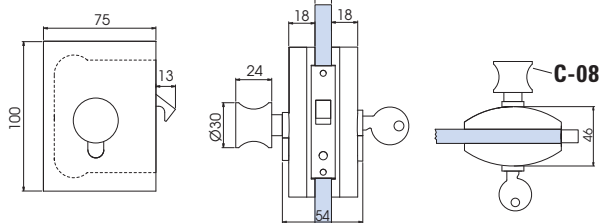

C-06

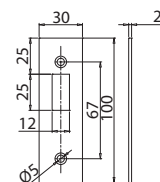
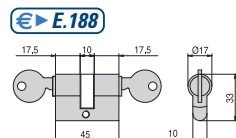

V-022

V-554 2FLG

€►E.186

V-557

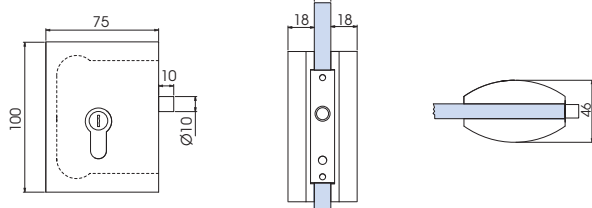

C-08

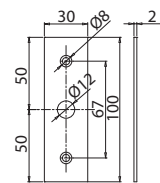
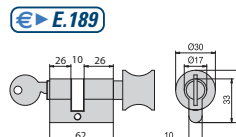

V-023

V-557 2FLG

€►E.187

V-555

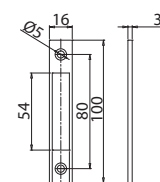
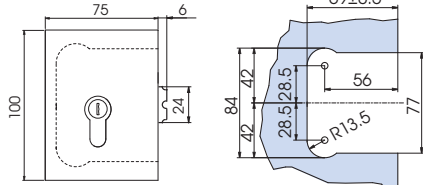

V-002



CS
Cromo satinato
Satin chrome
Chrom matt

NS
Nickel satinato
Satin nickel
Ähnlich Edelstahl matt

CR
Cromo lucido
Polished chrome
Chrom glänzend

CP
Cromo perla
Chrome perla similar Alu
Chrom perla ähnlich Alu

OL
Ottone lucido
Polished brass
Messing poliert

V-529 / V-530 CONTROSERRATURA

CONTROSERRATURA PER SCORREVOLI ESTERNO MURO

STRIKE BOX FOR SLIDING LOCKS ALONG THE WALL / GEGENKASTEN FÜR SCHIEBETÜREN AUF DER WAND



V-529

€ E.193

- Controserratura montaggio a muro completo di contropiastra reversibile regolabile per serrature V-504 / V-518 / V-554 / V-734 / V-724
- Wall installation strike box complete with adjustable plate for locks V-504 / V-518 / V-554 / V-734 / V-724
- Gegenkasten für Wandmontage mit verstellbares Schießblech für Schlösser V-504 / V-518 / V-554 / V-734 / V-724

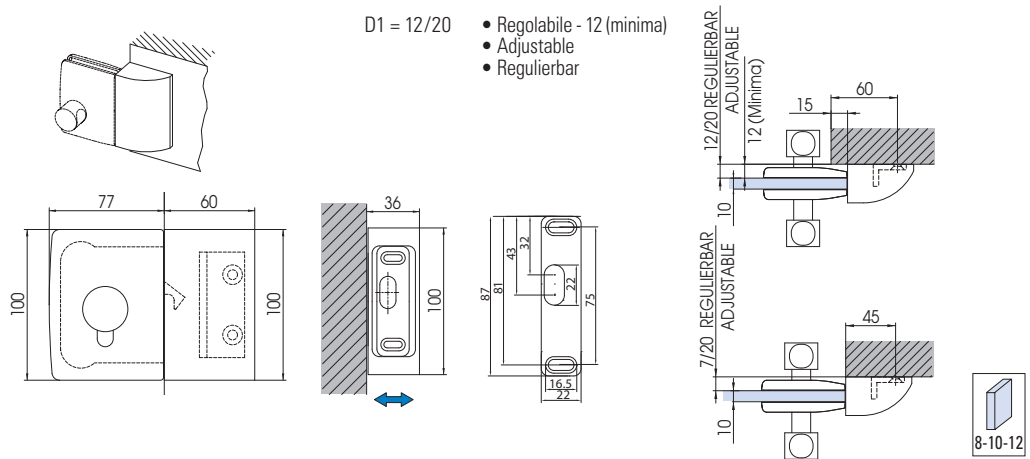

D1 = 12/20

- Regolabile - 12 (minima)
- Adjustable
- Regulierbar



V-530

€ E.194

- Controserratura montaggio a vetro completo di contropiastra reversibile regolabile per serrature V-504 / V-518 / V-554 / V-734 / V-724
- Glass installation strike box complete with adjustable plate for locks V-504 / V-518 / V-554 / V-734 / V-724
- Gegenkasten für Glasmontage mit verstellbares Schießblech für Schlösser V-504 / V-518 / V-554 / V-734 / V-724

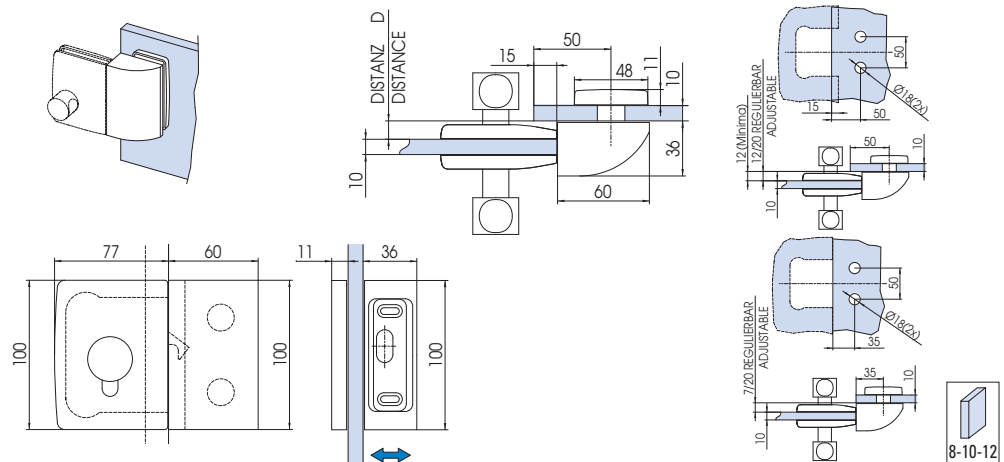

DISTANZ
DISTANCE

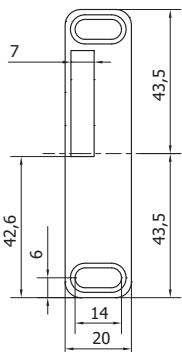

V-531

€ E.194.1

- Contropiastra aggiuntiva necessaria per montaggio con serratura V-404 / V-604 / V-407 con controserrature V-530 / V-529
- Additional strike plate required for locks V-404 / V-604 / V-407 with strike boxes V-530 / V-529
- Zusätzlich Schießblech erforderlich für Schlösser V-404 / V-604 / V-407 mit Gegenkasten V-530 / V-529

SERRATURE

pla247a6

CS
Cromo satinato
Satin chrome
Chrom matt

NS
Nickel satinato
Satin nickel
Ähnlich Edelstahl matt

CR
Cromo lucido
Polished chrome
Chrom glänzend

CP
Cromo perla
Chrome perla similar Alu
Chrom perla ähnlich Alu

MINIMA 55



SERRATURE



MINIMA 55



- Serrature Minima 55 con gancio per scorrevole o chiavistello tondo.
- Locks Minima 55 with hook for sliding doors or with rounded dead bolt.
- Cylinders and strike plates not included, to order separately.
- Minima 55 Schlösser mit Hakenriegel für Schiebetüren oder Mittelschloss mit Bolzen.
- Zylinder und Schließbleche nicht enthalten, separat zu bestellen.

V-564 € E.195



V-565 € E.196

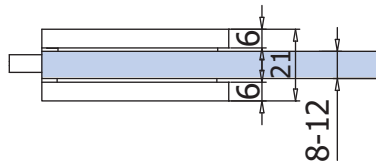
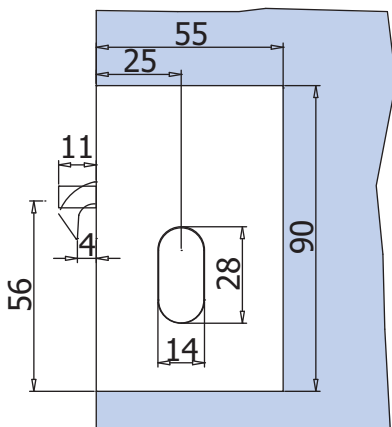

LAVORAZIONE VETRO
GLASS PREPARATION
GLASBEARBEITUNG

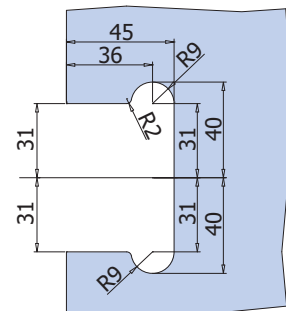

xme 496

C-010

€ E.198

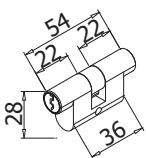

C-011

€ E.199

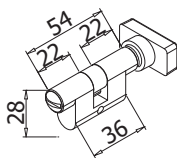

C-012

€ E.200

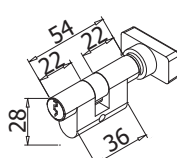

V-569 2FLG € E.197

- Controserratura
- Strike box
- Gegenkasten

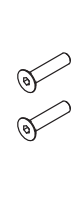
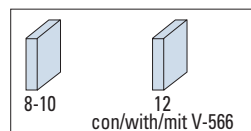
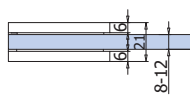
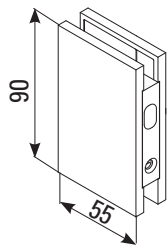
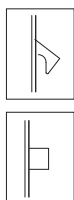

V-566 € E.204

- Spessore per vetro 12 mm
- Spacer for glass thickness 12 mm
- Distanzscheibe für Glasdicke 12 mm

V-568

€ E.201

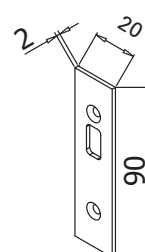

V-567 DX

€ E.202

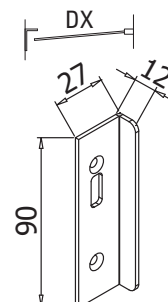

V-567 SX

€ E.203

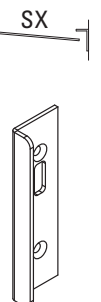

CP
Cromo perla
Chrome perla similar Alu
Chrom perla ähnlich Alu

NS
Nickel satinato
Satin nickel
Ähnlich Edelstahl matt

CR
Cromo lucido
Polished chrome
Chrom glänzend

MINIMA 55 COLOR



- Serrature Minima 55 Color con gancio per scorrevole o chiavistello tondo, indicatore WC colorato. Contropiastre da ordinare a parte.
- Locks Minima 55 Color with hook for sliding doors or with rounded dead bolt, with coloured indicator. Strike plates not included, to order separately.
- Minima 55 Color Schlösser mit Hakenriegel für Schiebetüren oder Mittelschloss mit Bolzen, mit Farbenanzeige. Schließbleche nicht enthalten, separat zu bestellen.

V-564 COLOR €►E.205



V-565 COLOR €►E.206

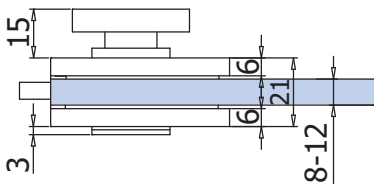
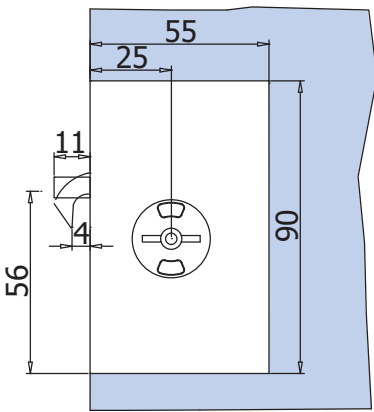

LAVORAZIONE VETRO
GLASS PREPARATION
GLASBEARBEITUNG

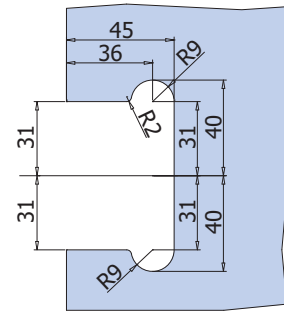

V-566 €►E.211

- Spessore per vetro 12 mm
- Spacer for glass thickness 12 mm
- Distanzscheibe für Glasdicke 12 mm

xme 496

V-569 2FLG €►E.207

- Controserratura
- Strike box
- Gegenkasten

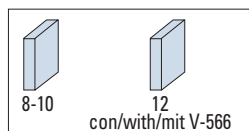
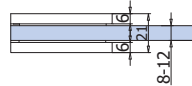
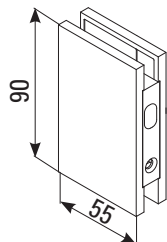
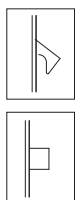

V-568

€►E.208

V-567 DX

€►E.209

V-567 SX

€►E.210

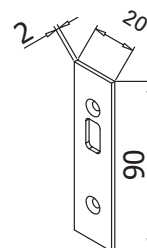

DX

SX

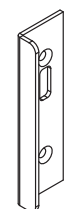
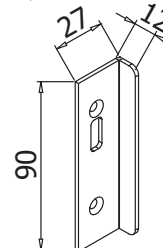

CP
Cromo perla
Chrome perla similar Alu
Chrom perla ähnlich Alu

NS
Nickel satinato
Satin nickel
Ähnlich Edelstahl matt

CR
Cromo lucido
Polished chrome
Chrom glänzend

SERRATURE

MINIMA 55 LEVER



V-584 €►E.212



V-585 €►E.213



- Serrature Minima 55 Lever con gancio per scorrevole o chiavistello tondo. Cilindri e contropiastre da ordinare a parte.
- Locks Minima 55 Lever with hook for sliding doors or with rounded dead bolt. Cylinders and strike plates not included, to order separately.
- Minima 55 Lever Schlösser mit Hakenriegel für Schiebetüren oder Mittelschloss mit Bolzen. Zylinder und Schließbleche nicht enthalten, separat zu bestellen.

SERRATURE

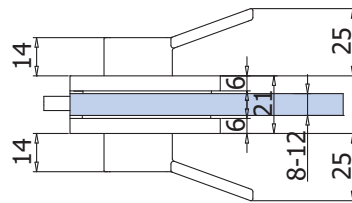
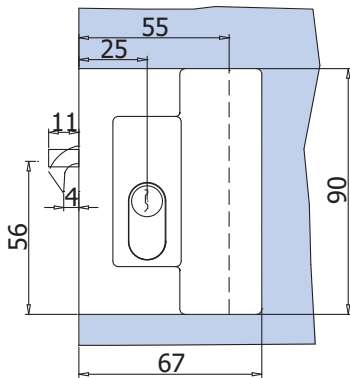

xme 496

LAVORAZIONE VETRO
GLASS PREPARATION
GLASBEARBEITUNG

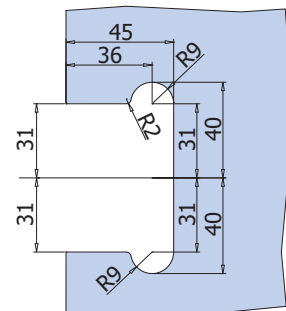

C-020 €►E.215

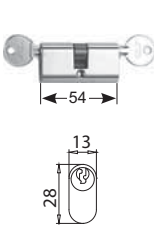

C-021 €►E.216

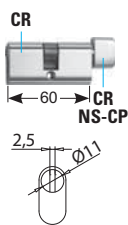

C-019 €►E.217

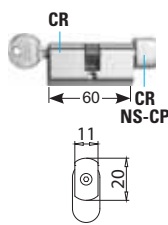

V-569 2FLG €►E.214

- Controserratura
- Strike box
- Gegenkasten

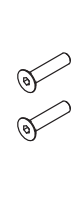
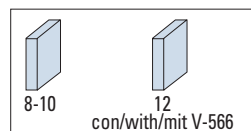
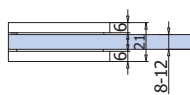
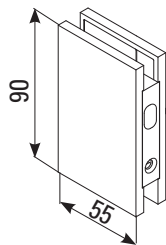
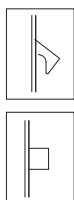

V-566 €►E.221

- Spessore per vetro 12 mm
- Spacer for glass thickness 12 mm
- Distanzscheibe für Glasdicke 12 mm

V-568 €►E.218

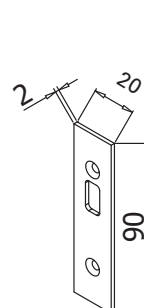

V-567 DX €►E.219

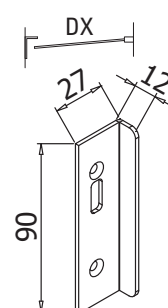

V-567 SX €►E.220

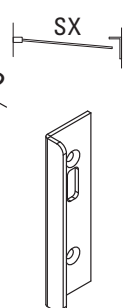

CP
Cromo perla
Chrome perla similar Alu
Chrom perla ähnlich Alu

NS
Nickel satinato
Satin nickel
Ähnlich Edelstahl matt

CR
Cromo lucido
Polished chrome
Chrom glänzend

MINIMA 55 LEVER COLOR



V-584 COLOR

€► E.222



V-585 COLOR

€► E.223



- Serrature Minima 55 Lever Color con gancio per scorrevole o chiavistello tondo, indicatore WC colorato. Contropiastre da ordinare a parte.
- Locks Minima 55 Lever Color with hook for sliding doors or with rounded dead bolt, with coloured indicator. Strike plates not included, to order separately.
- Minima 55 Lever Color Schlösser mit Hakenriegel für Schiebetüren oder Mittelschloss mit Bolzen, mit Farbenanzeige. Schließbleche nicht enthalten, separat zu bestellen.

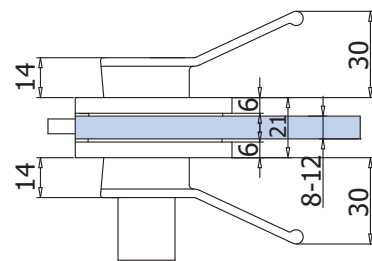
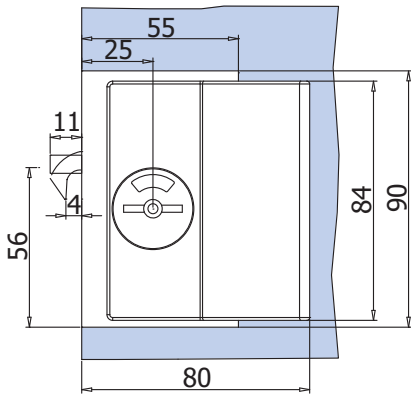

xme 496

LAVORAZIONE VETRO
GLASS PREPARATION
GLASBEARBEITUNG

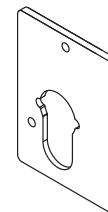
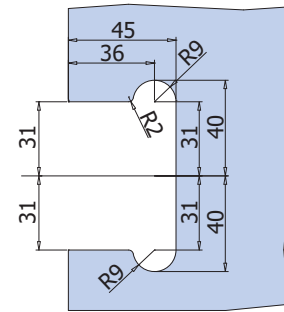

V-566 €► E.228

- Spessore per vetro 12 mm
- Spacer for glass thickness 12 mm
- Distanzscheibe für Glasdicke 12 mm

SERRATURE

V-569 2FLG €► E.224

- Controserratura
- Strike box
- Gegenkasten

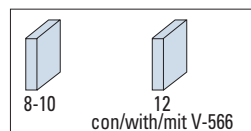
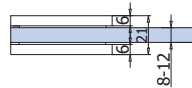
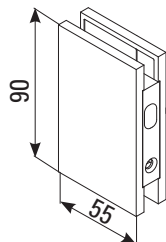
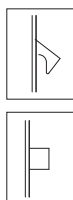

V-568

€► E.225

V-567 DX

€► E.226

V-567 SX

€► E.227

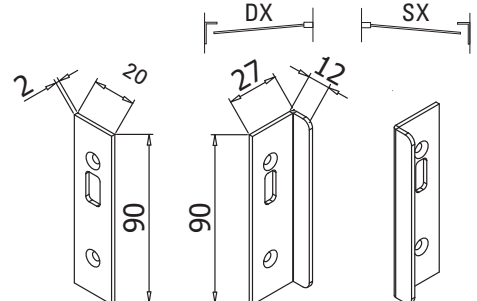

CP
Cromo perla
Chrome perla similar Alu
Chrom perla ähnlich Alu

NS
Nickel satinato
Satin nickel
Ähnlich Edelstahl matt

CR
Cromo lucido
Polished chrome
Chrom glänzend

MINIMA 55 DRAG



V-594 €►E.229



- Serrature Minima 55 Drag con gancio per scorrevole. Cilindri e contropiastre da ordinare a parte.
- Locks Minima 55 Drag with hook for sliding doors. Cylinders and strike plates not included, to order separately.
- Minima 55 Drag Schlösser mit Hakenriegel für Schiebetüren. Zylinder und Schließbleche nicht enthalten, separat zu bestellen.

SERRATURE

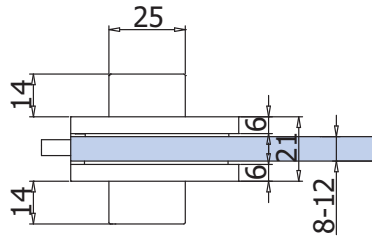
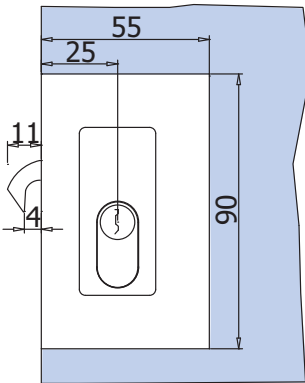

xme 496

LAVORAZIONE VETRO
GLASS PREPARATION
GLASBEARBEITUNG

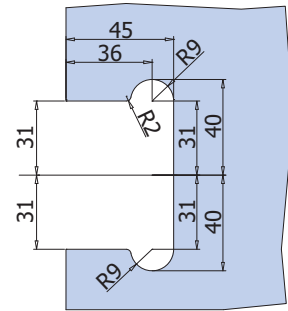

C-020
€►E.231

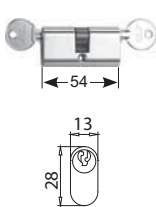

C-021
€►E.232

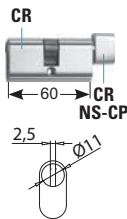

C-019
€►E.233

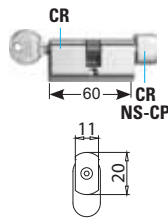

V-569 2FLG €►E.230

- Controserratura
- Strike box
- Gegenkasten

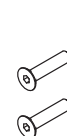
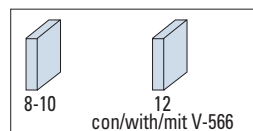
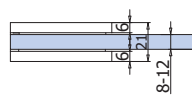
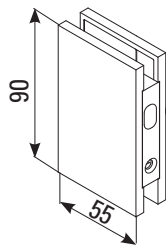
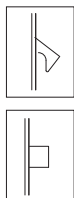

V-566 €►E.237

- Spessore per vetro 12 mm
- Spacer for glass thickness 12 mm
- Distanzscheibe für Glasdicke 12 mm

V-568
€►E.234

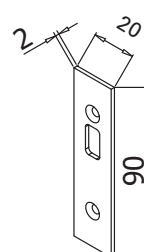

V-567 DX
€►E.235

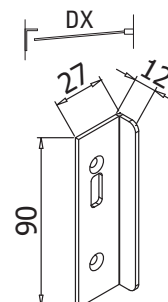

V-567 SX
€►E.237

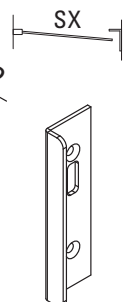

CP
Cromo perla
Chrome perla similar Alu
Chrom perla ähnlich Alu

NS
Nickel satinato
Satin nickel
Ähnlich Edelstahl matt

CR
Cromo lucido
Polished chrome
Chrom glänzend

MINIMA 55 DRAG COLOR



V-594 COLOR €►E.238



- Serrature Minima 55 Drag Color con gancio per scorrevole, indicatore WC colorato. Contropiastre da ordinare a parte.
- Locks Minima 55 Drag Color with hook for sliding doors, with coloured indicator. Strike plates not included, to order separately.
- Minima 55 Drag Color Schlösser mit Hakenriegel für Schiebetüren, mit Farbenanzeige. Schließbleche nicht enthalten, separat zu bestellen.

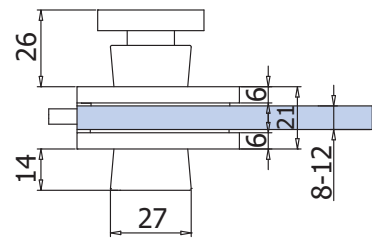
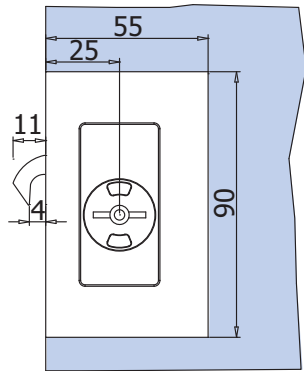

LAVORAZIONE VETRO
GLASS PREPARATION
GLASBEARBEITUNG

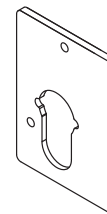
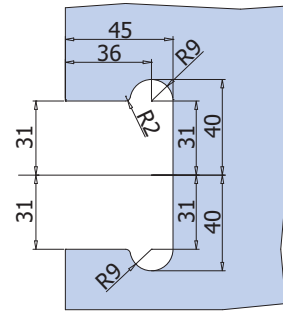

V-566 €►E.243

- Spessore per vetro 12 mm
- Spacer for glass thickness 12 mm
- Distanzscheibe für Glasdicke 12 mm

xme 496

V-569 2FLG €►E.239

- Controserratura
- Strike box
- Gegenkasten

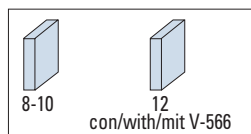
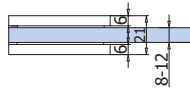
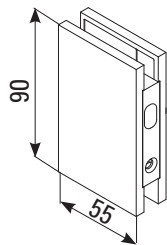
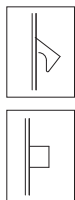

V-568

€►E.240

V-567 DX

€►E.241

V-567 SX

€►E.242

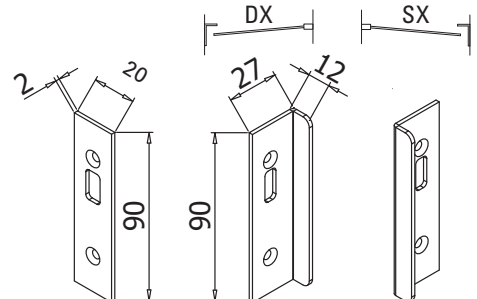

CP
Cromo perla
Chrome perla similar Alu
Chrom perla ähnlich Alu

NS
Nickel satinato
Satin nickel
Ähnlich Edelstahl matt

CR
Cromo lucido
Polished chrome
Chrom glänzend

SERRATURE

MINIMA 55 RIBASSATA



V-574 €►E.244



V-575 €►E.245



- Serrature Minima 55 Ribassata con gancio per scorrevole, chiavistello tondo e scrocco ad olivetta. Cilindri e contropiastre da ordinare a parte
- Locks Minima 55 Lowered with Hook for sliding doors, with rounded dead bolt or with double bevelled latch. Cylinders and strike plates not included, to order separately.
- Minima 55 abgerundete kante mit Hakenriegel für Schiebetüren oder Mittelschloss mit Bolzen. Zylinder und Schließbleche nicht enthalten, separat zu bestellen.

SERRATURE

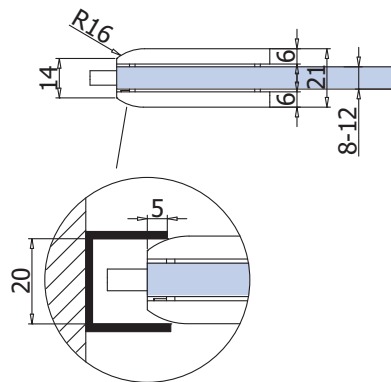
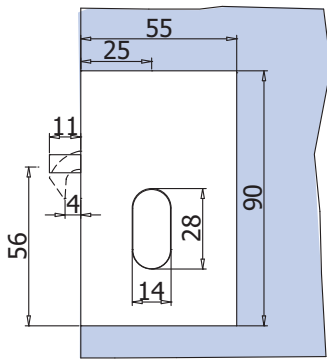

LAVORAZIONE VETRO
GLASS PREPARATION
GLASBEARBEITUNG

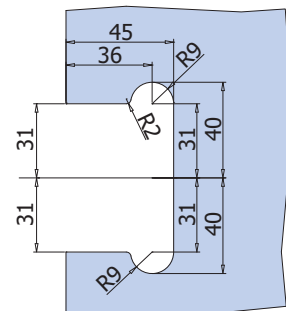

xme 445

C-010

€►E.247

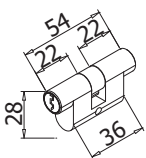

C-011

€►E.248

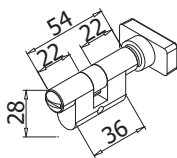

C-012

€►E.249

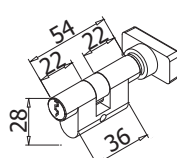

V-569 2FLG €►E.246

- Controserratura
- Strike box
- Gegenkasten

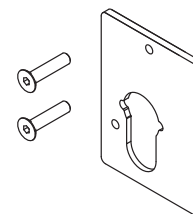
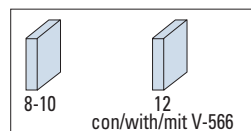
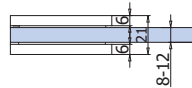
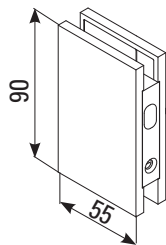
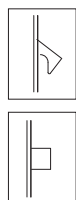

V-566 €►E.253

- Spessore per vetro 12 mm
- Spacer for glass thickness 12 mm
- Distanzscheibe für Glasdicke 12 mm

V-568

€►E.250

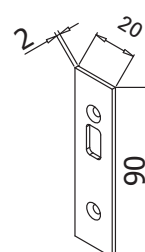

V-567 DX

€►E.251

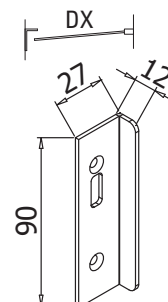

V-567 SX

€►E.252

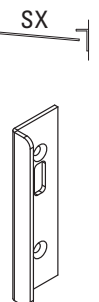

CP
Cromo perla
Chrome perla similar Alu
Chrom perla ähnlich Alu

NS
Nickel satinato
Satin nickel
Ähnlich Edelstahl matt

CR
Cromo lucido
Polished chrome
Chrom glänzend



SERRATURE

EASY LOCK

- Serrature Easy Lock con chiavistello tondo, contropiastra inclusa.
- Locks Easy Lock with rounded dead bolt, strike plate included.
- Easy Lock Schlösser mit Bolzen, Schließblech enthalten.



V-785 €►E.254



V-785 COLOR €►E.255



V-785

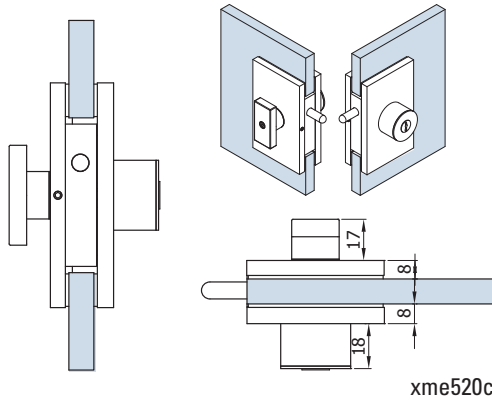
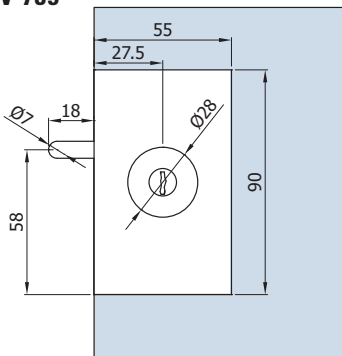

xme520c

LAVORAZIONE VETRO
GLASS PREPARATION
GLASBEARBEITUNG

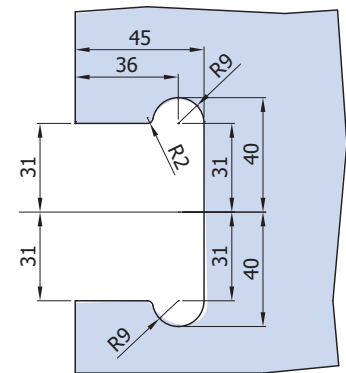

V-785 COLOR

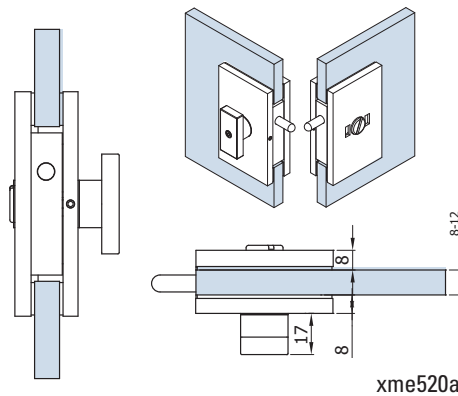
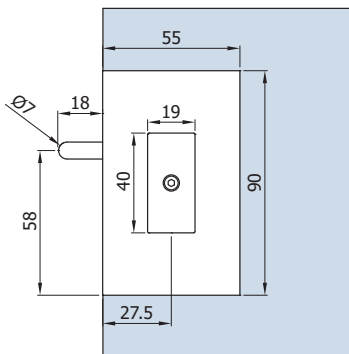

xme520a

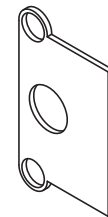
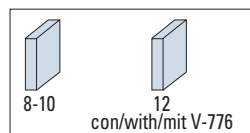

V-776 €►E.259

- Spessore per vetro 12 mm
- Spacer for glass thickness 12 mm
- Distanzscheibe für Glasdicke 12 mm

V-779 2FLG €►E.258

- Controserratura
- Strike box
- Gegenkasten

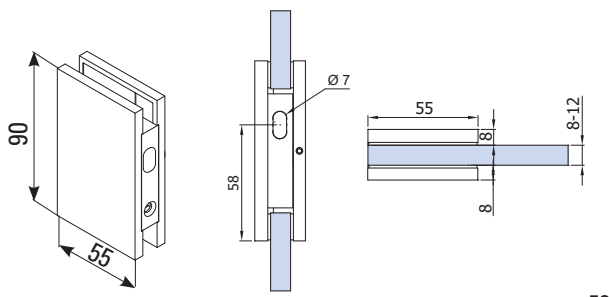

xme520

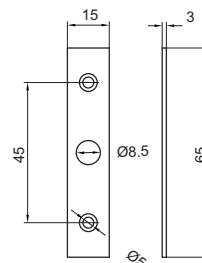

- Contropiastra inclusa
- Strike plate included
- Schließblech enthalten

CP
Cromo perla
Chrome perla similar Alu
Chrom perla ähnlich Alu

NS
Nickel satinato
Satin nickel
Ähnlich Edelstahl matt

CR
Cromo lucido
Polished chrome
Chrom glänzend

EASY LOCK LEVER

- Serrature Easy Lock Lever con chiavistello tondo, contropiastra inclusa.
- Locks Easy Lock Lever with rounded dead bolt, strike plate included.
- Easy Lock Lever Schlösser mit Bolzen, Schließblech enthalten.



V-775 € E.256



V-775 COLOR € E.257



V-775

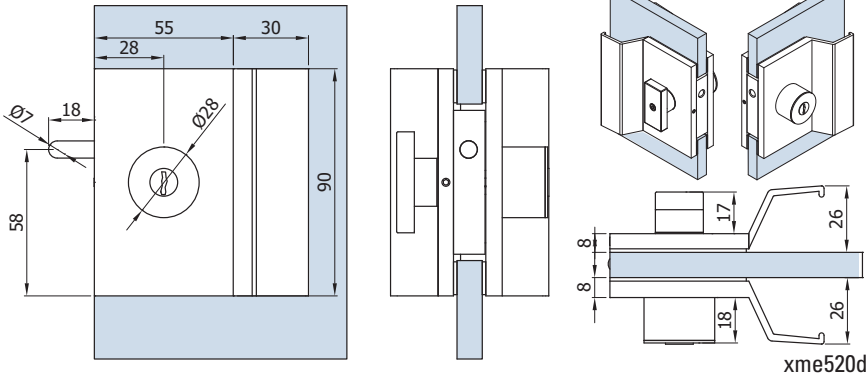

LAVORAZIONE VETRO
GLASS PREPARATION
GLASBEARBEITUNG

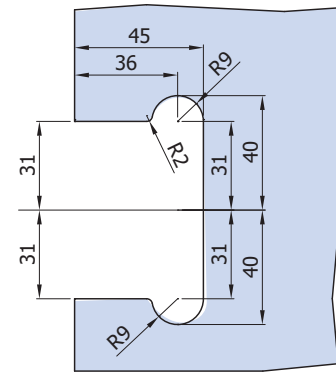

V-775 COLOR

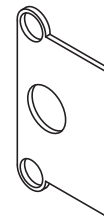
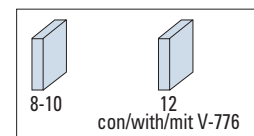
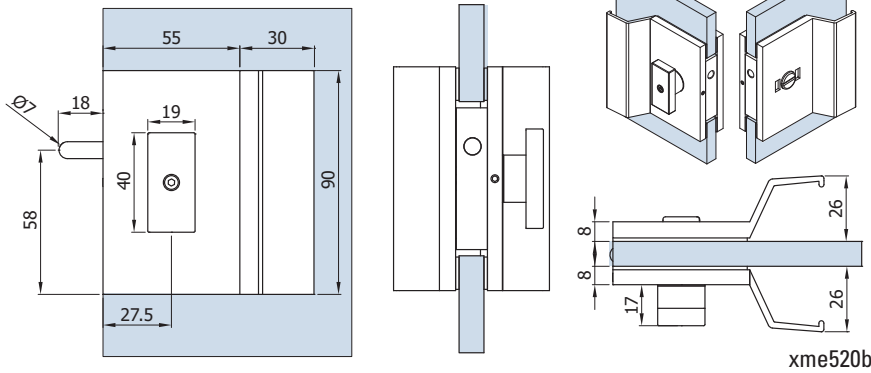

V-776 € E.259

- Spessore per vetro 12 mm
- Spacer for glass thickness 12 mm
- Distanzscheibe für Glasdicke 12 mm

V-779 2FLG € E.258

- Controserratura
- Strike box
- Gegenkasten

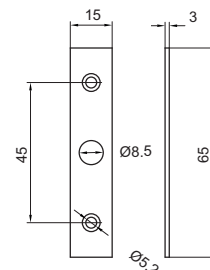
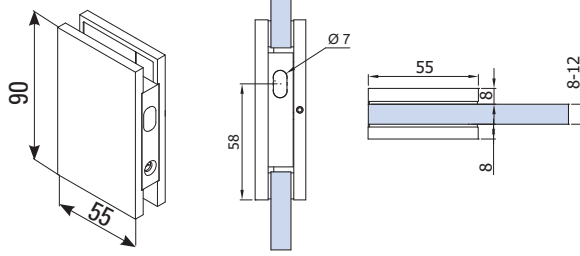

- Contropiastra inclusa
- Strike plate included
- Schließblech enthalten

xme520

CP
Cromo perla
Chrome perla similar Alu
Chrom perla ähnlich Alu

NS
Nickel satinato
Satin nickel
Ähnlich Edelstahl matt

CR
Cromo lucido
Polished chrome
Chrom glänzend

SERRATURA PER SCORREVOLI CON TIRANTE
LOCKS WITH FLUSH PULL FOR SLIDING DOORS
SCHLÖSSER FÜR SCHIEBETÜREN MIT STIRNSEITIGEM GRIFF

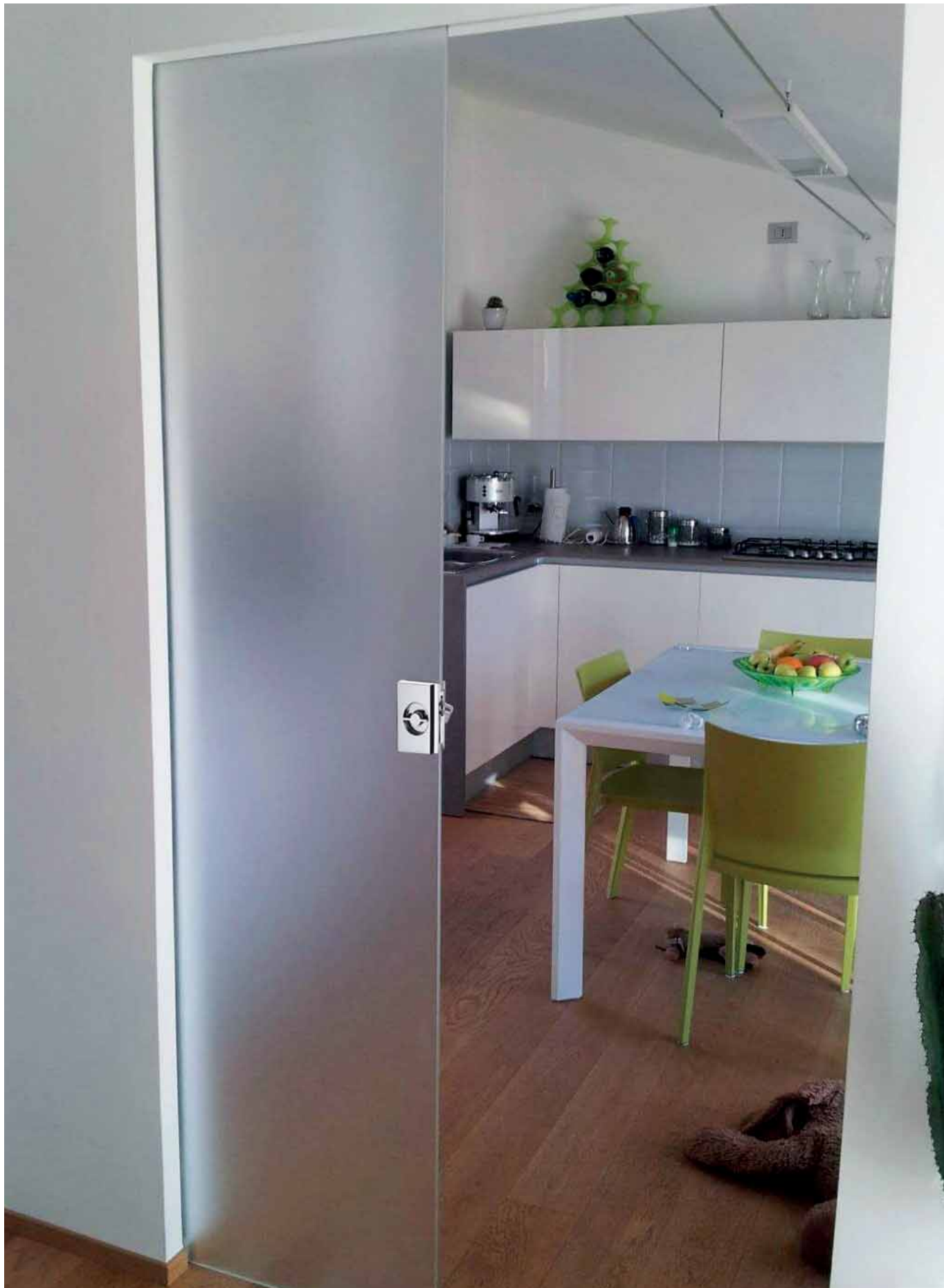

SERRATURE

V-404



V-404 PO-WC

€ E.260

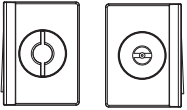

- Leva
- WC apertura emergenza
- Lever
- WC emergency open
- Griff
- WC Notöffnung

V-404 PO-PO

€ E.261

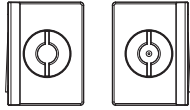

- Leva
- Griff
- Leva
- Griff

V-404 2FLG

€ E.264

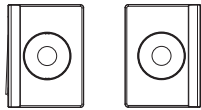

- Tappo cieco
- Blind
- Tappo cieco
- Blind

V-404 PO-2FLG

€ E.263

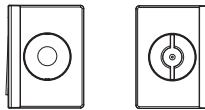

- Tappo cieco
- Blind
- Leva
- Griff

V-404 WC COLOUR

€ E.262

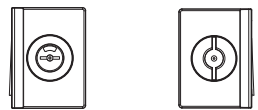

- Indicatore colorato
- Coloured indicator
- Schliessanzeige
- Leva
- Griff

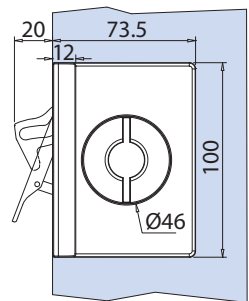

- Scorrevole a scomparsa (solo vetro 8 mm)
- Pocket doors (only 8 mm)
- Schiebetüren in der Wand laufend (nur 8 mm Glas)

- Contropiastra inclusa
- Strike plate included
- Schließblech im Set enthalten

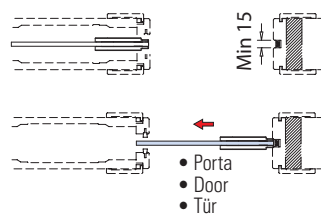

- Porta
- Door
- Tür

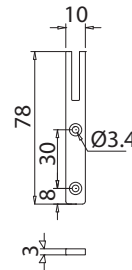

V-404 WC

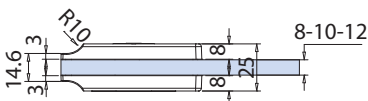
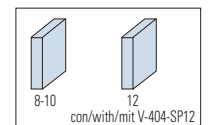

V-404 WC COLOUR

- Serratura per scorrevoli con tirante e indicatore colorato "libero/occupato".
- Locks with flush pull for sliding doors with WC latch and coloured indicator.
- Schlösser für Schiebetüren mit stirnseitigem Griff, und WC Schliessanzeige.

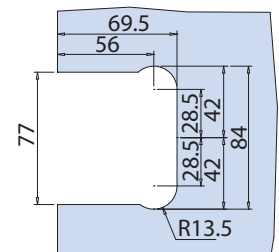

xfb053

CP
Cromo perla
Chrome perla similar Alu
Chrom perla ähnlich Alu

NS
Nickel satinato
Satin nickel
Ähnlich Edelstahl matt

CR
Cromo lucido
Polished chrome
Chrom glänzend

ALTRE SERRATURE OTHER LOCKS / ANDERE SCHLÖSSER



V-700 SQUARE

NS - CS - CR - OL - CP

€► E.88 → €► E.90

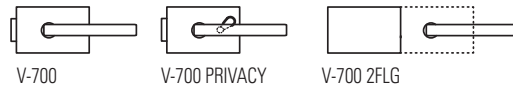
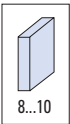
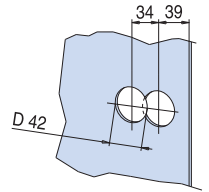
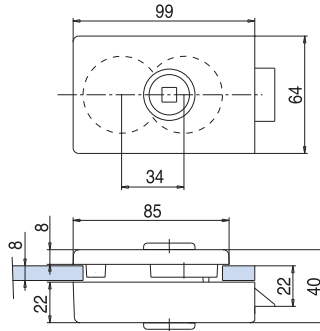

xla104



V-770 SECUR

NS - CS - CR - CP - OL

€► E.100 → €► E.104

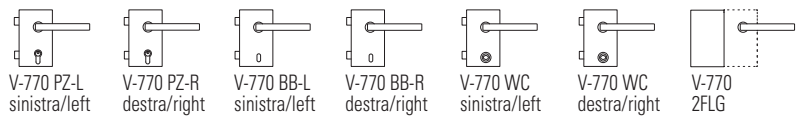
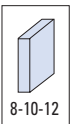
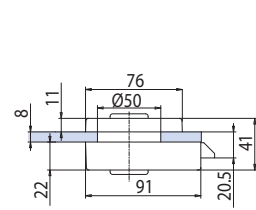
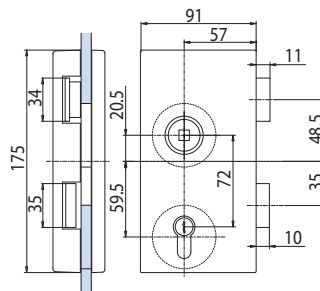
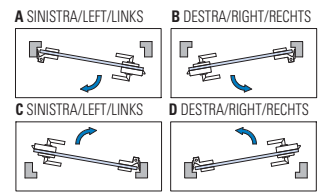

xla238



V-400 FERRARI

NS - CS - CR - CP - OL

€► E.91 → €► E.95

MV-400

- Versione magnetica
- Magnetic version
- Mit magnetischem Schließvorgang

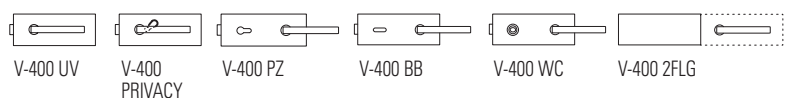
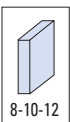
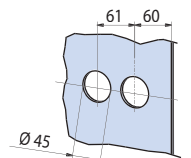
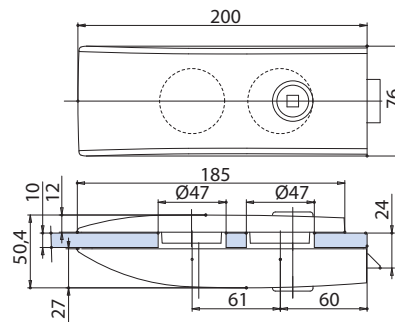

xla33



V-100 ONE

NS - CS - CR - OL

€▶ E.96 → €▶ E.99

MV-400

- Versione magnetica
- Magnetic version
- Mit magnetischem Schließvorgang

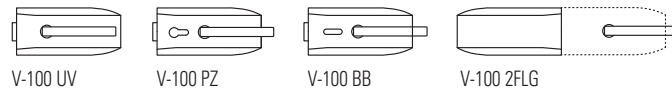
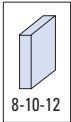
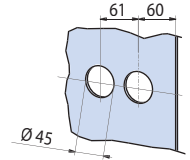
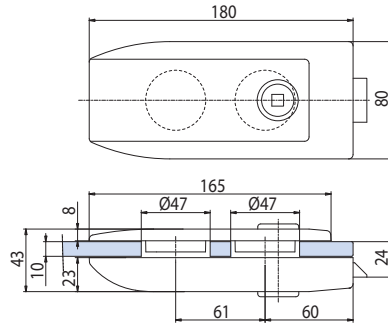

xla183



V-604 MINIMA

- Serratura per scorrevoli con tirante.
- Locks with flush pull for sliding doors.
- Schlösser für Schiebetüren mit Stirnseitigem Griff.

NS - CP

€▶ E.266 → €▶ E.276

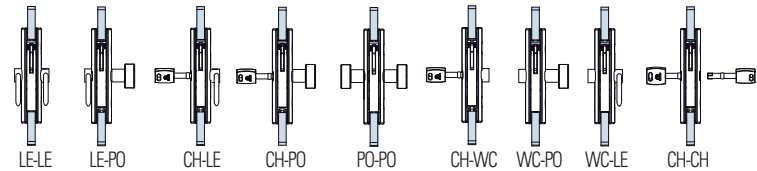
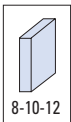
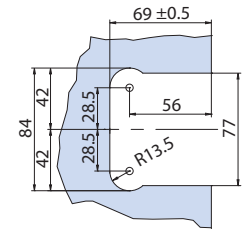
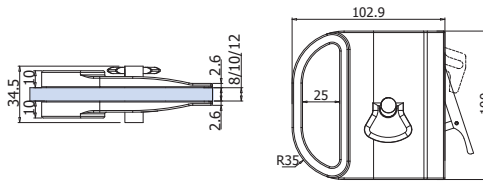

xme151 GER



V-407 MINIMA

- Serratura per scorrevoli con tirante.
- Locks with flush pull for sliding doors.
- Schlösser für Schiebetüren mit Stirnseitigem Griff.

NS - CP

€▶ E.277 → €▶ E.287

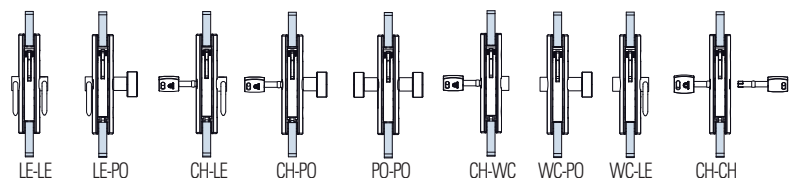
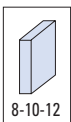
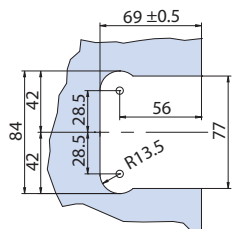
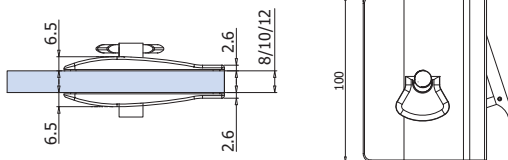

xme152

SERRATURE

CERNIERE VERTICALI SIDE HINGES / 3-TEILIGE BÄNDER

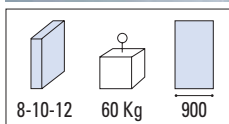

V-709 LIBRA

- Cerniera verticale con aletta fissaggio.
- Side Hinge with fixing plate.
- Band mit Anschraubplatte.

AN - CS - NS - CR - CP - NO

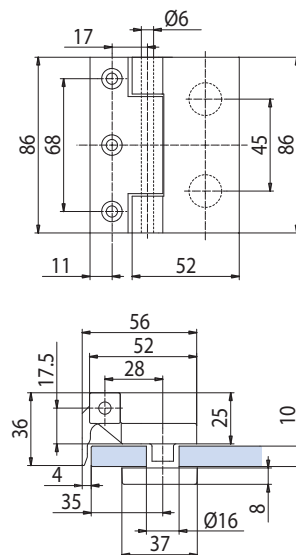

€ E.355

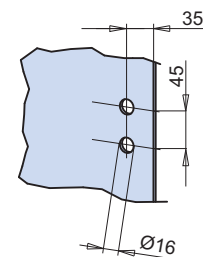

xla217

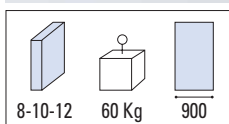

V-809

- Cerniera verticale con aletta fissaggio.
- Side Hinge with fixing plate.
- Band mit Anschraubplatte.

AN - NS - CR - CP

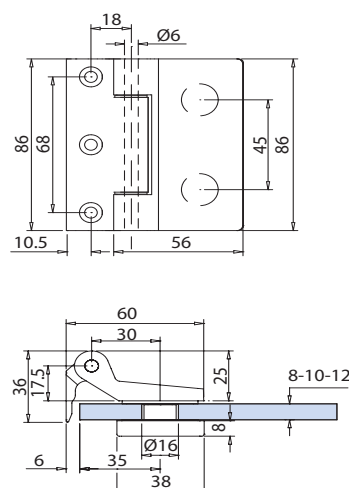

€ E.357

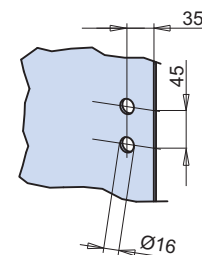

xme348

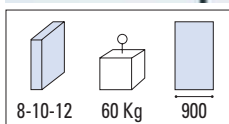

V-509 SLIM

- Cerniera con aletta fissaggio.
- Side hinge with fixing plate.
- Band mit Anschraubplatte.

AN - CS - NS - CR - CP - OL

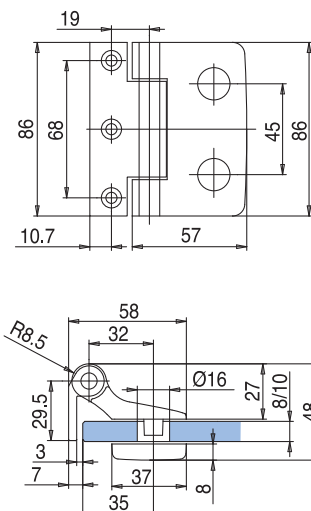

€ E.356

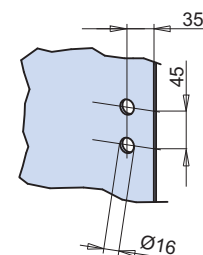

xla46



V-409 STILO

- Cerniera vertical con aletta fissaggio universale.
- Side Hinge with fixing plate.
- Band mit Anschraubplatte.

CS - NS - CR - CP

€▶ E.367

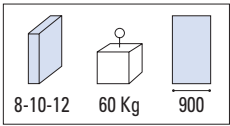
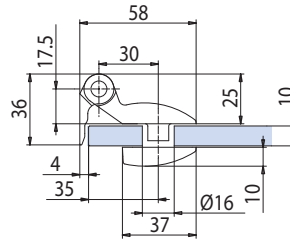
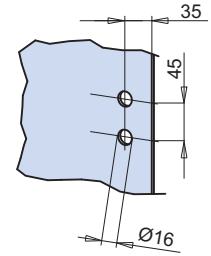
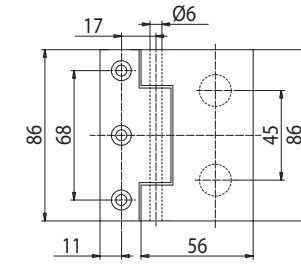

xla217



V-909

- Cerniera verticale con aletta fissaggio.
- Side Hinge with fixing plate.
- Band mit Anschraubplatte.

AN - IXE - NO

€▶ E.362

V-909-A

- Aletta optional per cerniera V-909 per incasso nello stipite
- Optional fixing plate for hinge V-909, installed flush with door jamb
- Optional Befestigungsplatte für Band V-909, bündige Montage in der Zarge

AN - IX

€▶ E.363

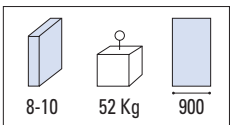
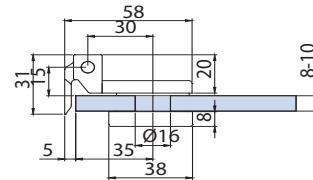
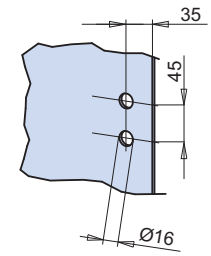
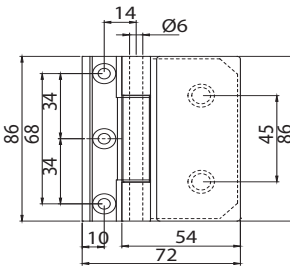
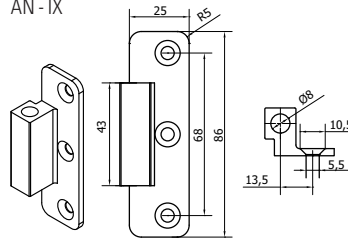

xme554



V-402

- Cerniera verticale tipo tedesco.
- Side Hinge german type.
- 3-teiliges Band einschl. Hülse für Rahmenteil DIN-NORM.

AN - IXE - CS - CR - CP - OL - NO

€▶ E.358

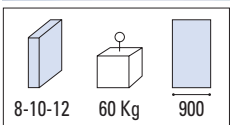
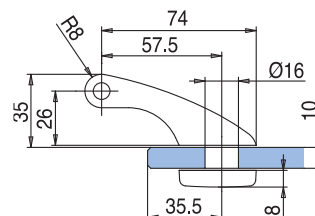
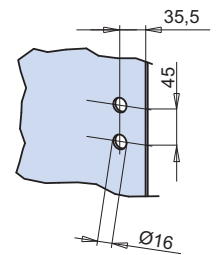
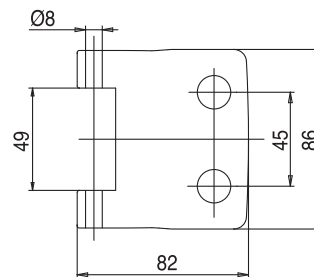

xla34

CERNIERE VERTICALI

SIDE HINGES / 3-TEILIGE BÄNDER



V-704 DX / V-704 SX

- Cerniera alto/basso regolabile in altezza, fissaggio laterale.
- Top/bottom hinge with height adjustment, side installation.
- Oberes/unteres Band Höhenverstellbar, seitliche Befestigung.

AN - CS - NS - CR - CP - NO

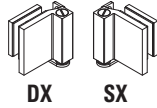

DX SX

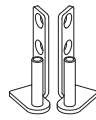

- V-703**
- incluso
 - included
 - enthalten

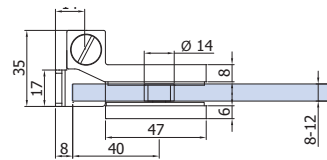
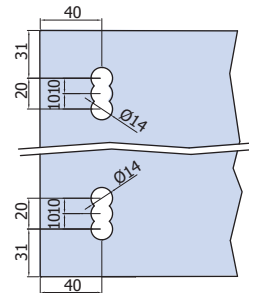
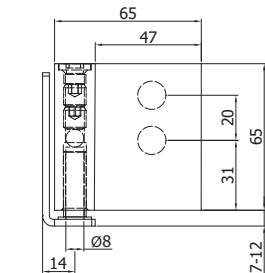
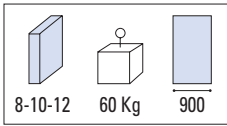

€▶ E.360

xme511



V-701

- Cerniera verticale con alette di fissaggio.
- Side hinge with fixing plate.
- Band mit Anschraubplatte.

AN - CS - NS - CR - CP - NO

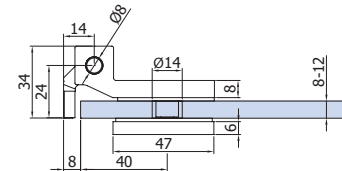
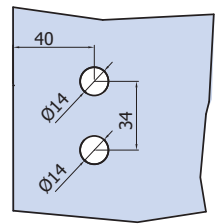
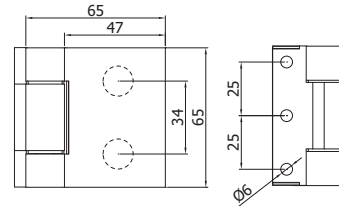
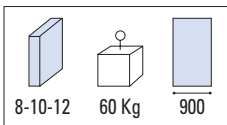

€▶ E.359

xme511

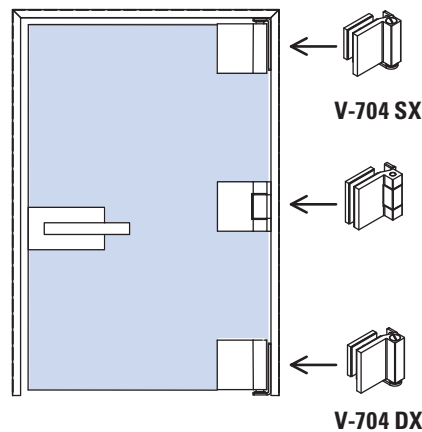

V-701

- Optional per altezze superiori a 2500 mm
- Optional for height door panel more than 2500 mm
- Optional für Tür höher als 2500 mm

€▶ E.359



NO
Patent Pending

V-729

- Cerniera verticale con alette fissaggio
- Side Hinge with fixing plate
- Band mit Anschraubplatte

AN - NS - CR

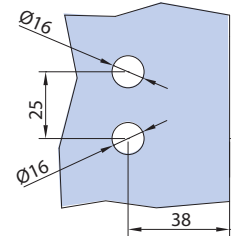
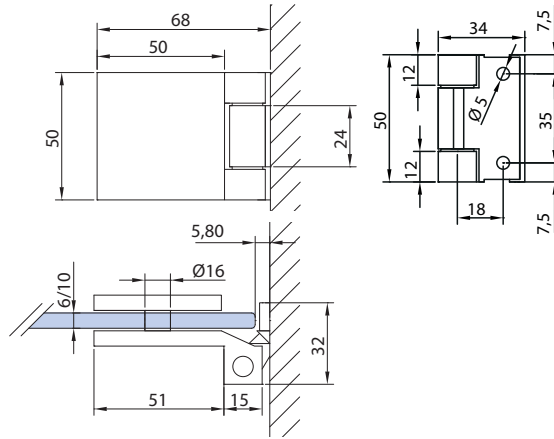

€ E.364

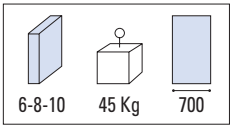

xme380



V-739

- Cerniera verticale vetro / vetro
- Hinge for glass / glass
- Band für Glas / Glas

AN - NS - CR

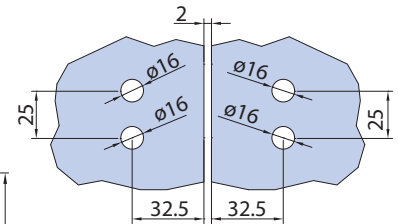
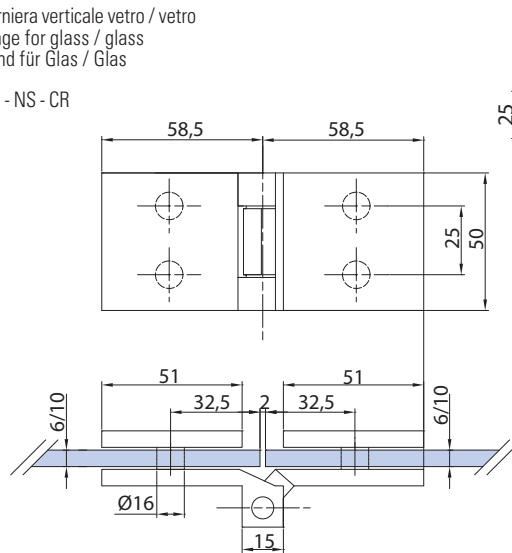

€ E.365

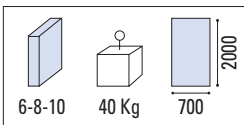

xme424



V-702 ZETA

- Cerniera verticale tipo tedesco.
- Side Hinge german type.
- 3-teilige Band einschl. Hülse für Rahmenteil DIN-NORM.

CS - NS - CR - CP

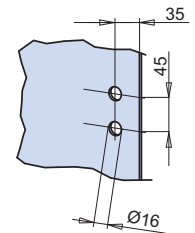
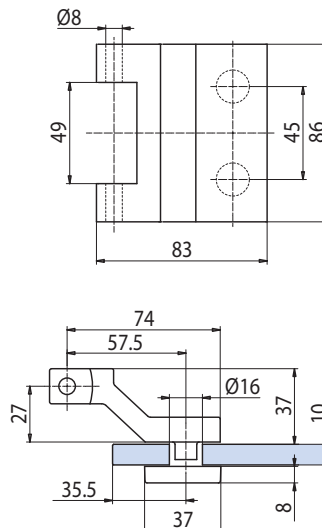

€ E.366

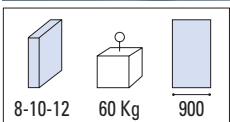

xla218

CERNIERE VERTICALI

SIDE HINGES / 3-TEILIGE BÄNDER



V-719 LIBRA

- Cerniera verticale per stipiti rasomuro P-060, P-070.
- Vertical hinge for door jambs P-060, P-070.
- Band für wandbündige Aluzargen P-060, P-070.

NS - CS - CR

€ E.368

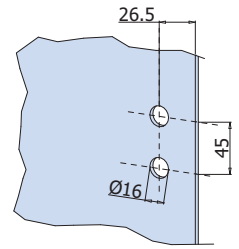
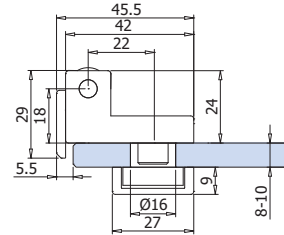
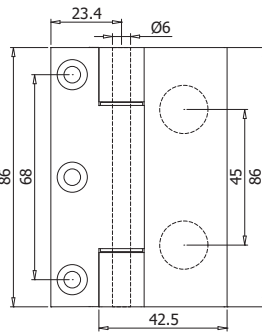
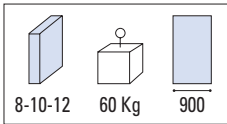

xme199l / xme199l-1



V-513 SLIM

- Cerniera verticale vetro/vetro.
- Hinge for glass/glass.
- Band für Glas/Glas.

NS - CS - CR - CP

€ E.369

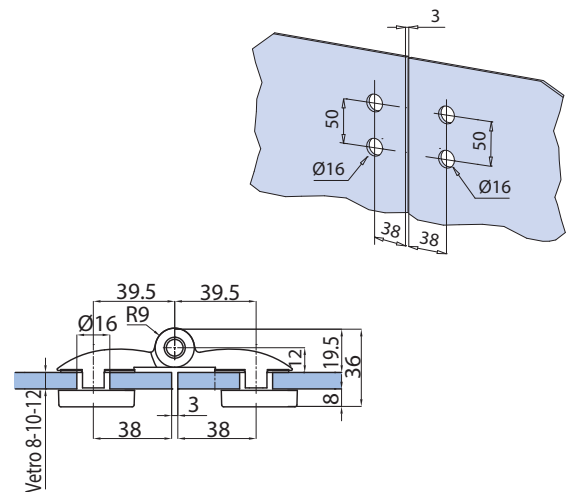
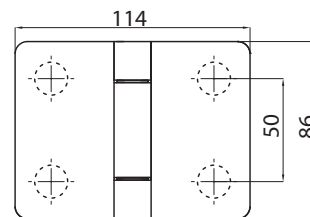
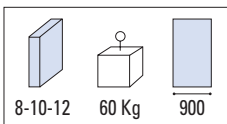

xme165 / xme165-1



V-107 SLIM

- Cerniera pavimento/soffitto regolabile.
- Top bottom hinge with height adjustable.
- Band, höhenverstellbar für oben/unten bzw. Seiten Befestigung.

NS - CS - CR - CP - OL

€ E.373

DISPONIBILE FINO AD ESAURIMENTO SCORTE
AVAILABLE WHILE STOCKS LAST
LIEFERBAR SOLANGE DER VORRAT REICHT

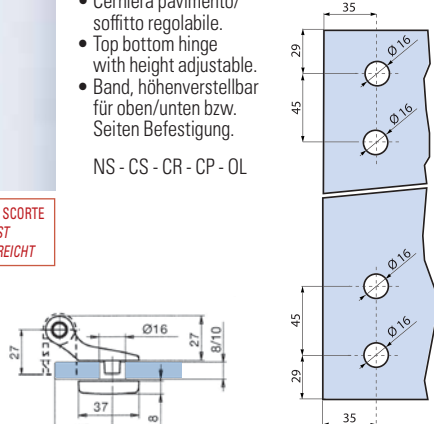
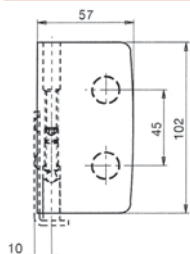

V-106

€ E.375

V-105

€ E.374

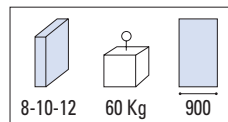

- non incluso
- not included
- nicht enthalten

xla153



V-707 DX / V-707 SX

- Cerniera a pavimento / soffitto regolabile.
- Top / bottom hinge with height adjustable.
- Band höhenverstellbar für oben/unten

NS - CS - CR - CP

€ E.370

DISPONIBILE FINO AD ESAURIMENTO SCORTE
AVAILABLE WHILE STOCKS LAST
LIEFERBAR SOLANGE DER VORRAT REICHT

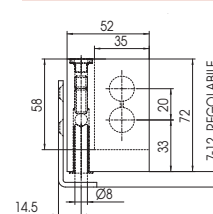

V-106

€ E.375

V-105

€ E.374

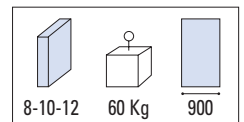

- non incluso
- not included
- nicht enthalten

xla265 / xla285



CERNIERE TUTT'ALTEZZA

HINGES PROFILES / BANDPROFILE



P-08

€ E.376

- Cerniera tutt'altezza ad incollaggio per applicazione su stipiti battuta da 40 mm. Altezza standard cerniera 2400 mm.
- Hinge profile. Glass to be glued. For frames with rebate depth 40 mm. Hinge standard height 2400 mm.
- Bandprofil (Glas wird geklebt) für Falztiefe 40 mm. Band standard Höhe 2400 mm.

AN

L=2400 mm

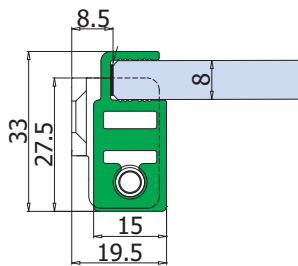
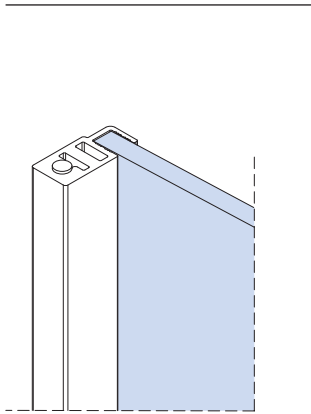
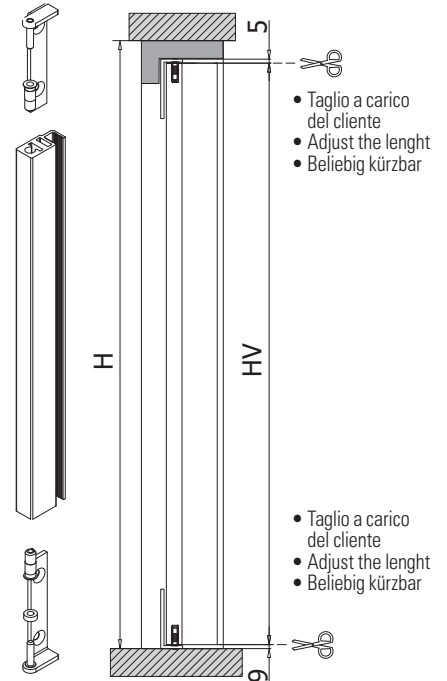

SW DP 105 (3M) / SW DP 610 (3M)

- Adesivo strutturale consigliato.
- Suggested structural glue.
- Empfehlung Klebstoff.

V-121-SD (incluso / included / enthalten)

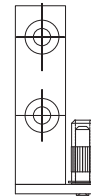
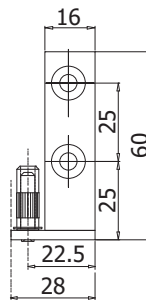

DX

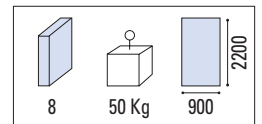

Cerniera applicabile ai seguenti stipiti / Hinge available for following frames / Band an folgende Zargen montierbar

P-030 / P-040

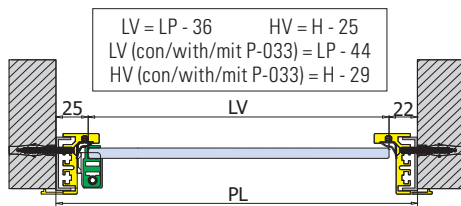
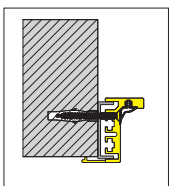

LV = LP - 36 HV = H - 25
LV (con/with/mit P-033) = LP - 44
HV (con/with/mit P-033) = H - 29

TP-250

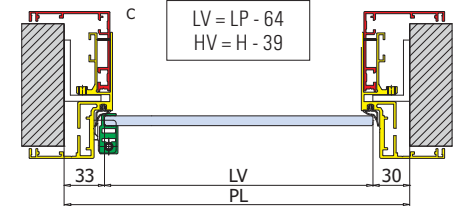
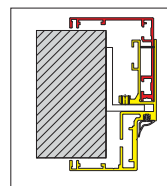

LV = LP - 64
HV = H - 39

TP-100

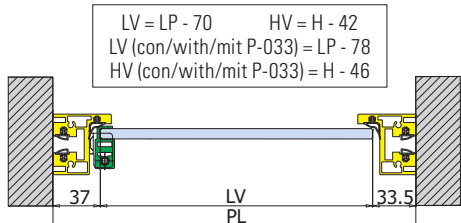
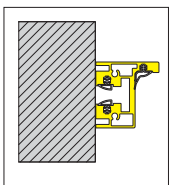

LV = LP - 70 HV = H - 42
LV (con/with/mit P-033) = LP - 78
HV (con/with/mit P-033) = H - 46

P-070

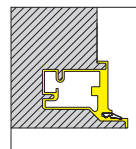

P-060

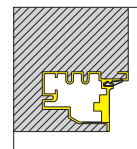

TP-201

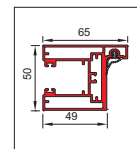

TP-300

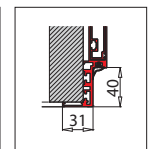

xme1991

LP Passaggio luce Clear opening width Lichte Durchgangsbreite	LV Larghezza vetro Glass width Glasbreite	HV Altezza vetro Glass height Glashöhe	H Altezza passaggio luce Clear opening height Lichte durchgangshöhe
---	---	--	---



P-09

€ E.379

- Cerniera tutt'altezza per applicazione su stipiti battuta da 40 mm. Altezza standard cerniera 2400 mm.
- Hinge profile. for frames with rebate depth 40 mm. Hinge standard height 2400 mm.
- Bandprofil für Falztiefe 40 mm. Band standard Höhe 2400 mm.

AN



L=2400 mm

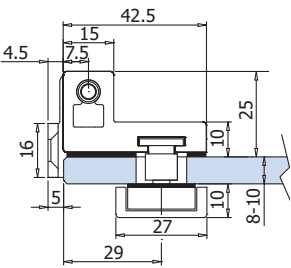
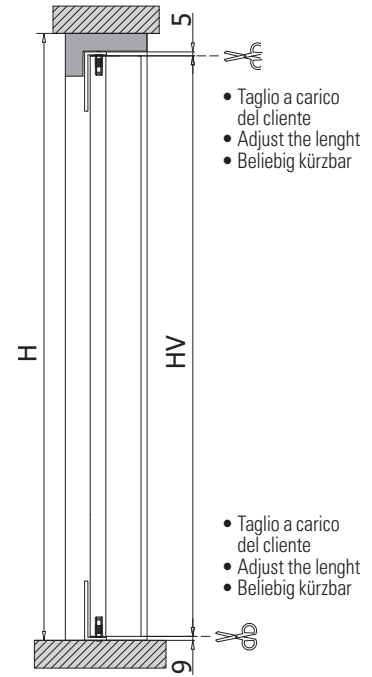

LAVORAZIONE VETRO
GLASS PREPARATION
GLASBEARBEITUNG

- I fori sul vetro possono essere posizionati a piacimento grazie alle bussole regolabili.
- The holes can be positioned at will thanks to the adjustable fixing points.
- Die Bohrungen können nach belieben durch die verstellbaren Befestigungspunkte positioniert werden.

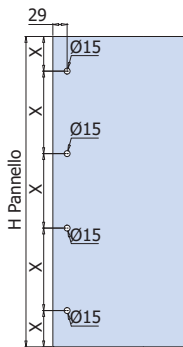
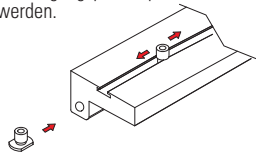

V-122-SD (incluso / included / enthalten)

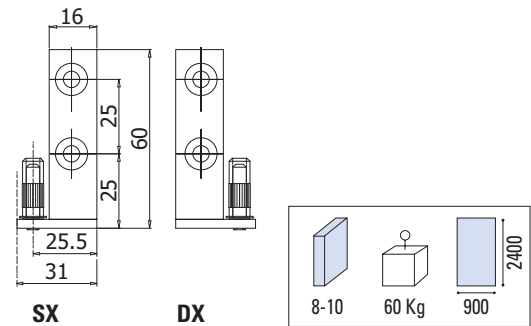

Cerniera applicabile ai seguenti stipiti / Hinge available for following frames / Band an folgende Zargen montierbar

P-030 / P-040

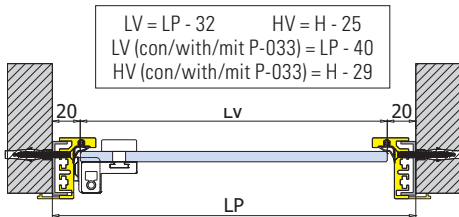
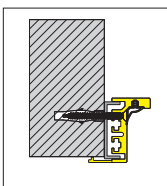

TP-250

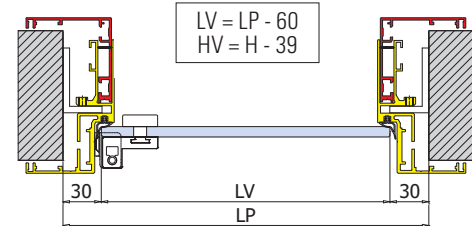
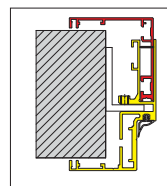

TP-100

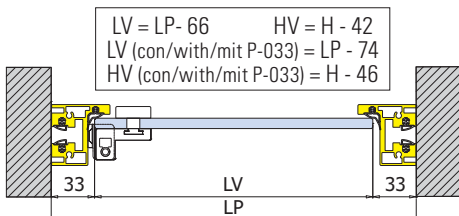
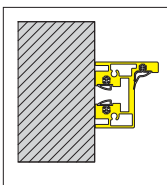

P-070

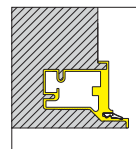

P-060

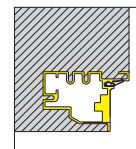

TP-201

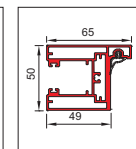

TP-300

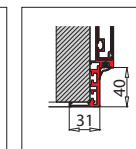

xme199c2 / xme199i

LP
Passaggio luce
Clear opening width
Lichte Durchgangsbreite

LV
Larghezza vetro
Glass width
Glasbreite

HV
Altezza vetro
Glass height
Glashöhe

H
Altezza passaggio luce
Clear opening height
Lichte durchgangshöhe

CERNIERE ORIZZONTALI

HORIZONTAL HINGES / 2-TEILIGE BÄNDER

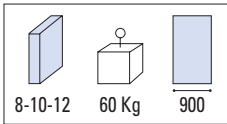

V-201

- Cerniera Tonda tipo tedesco.
- Side hinge Tonda German type.
- 2-teiliges Band Tonda einschl. Hülse.

AN - IXE - CS - CR - CP - OL

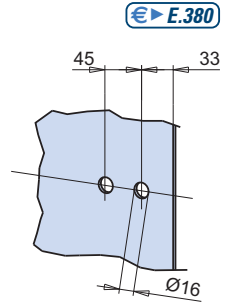
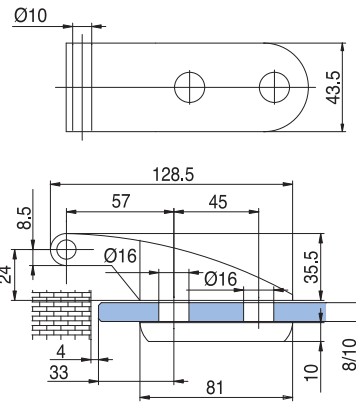

€ E.380

xme012

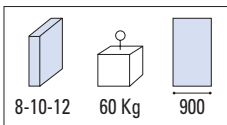

V-202

- Cerniera Tonda con aletta fissaggio per stipiti 28 mm.
- Round side hinge with fixing plate for rebates of 28 mm.
- Band Tonda mit Anschraubplatte für Falztiefe 28 mm.

AN - IXE - CS - CR - CP - OL

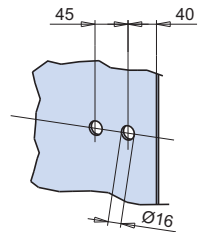
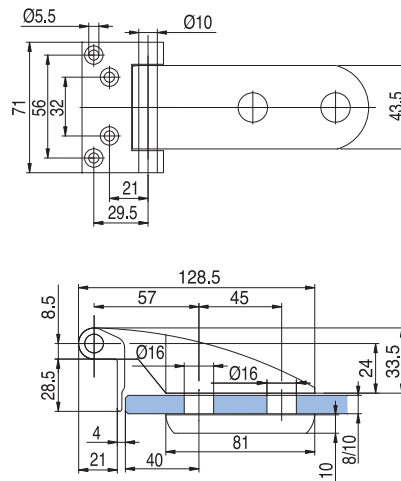

€ E.381

xme012

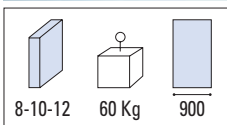

V-401 FERRARI

- Cerniera tipo tedesco.
- Side hinge german type.
- 2-teiliges Band einschl. Hülse.

AN - CS - IXE - CR - CP - OL

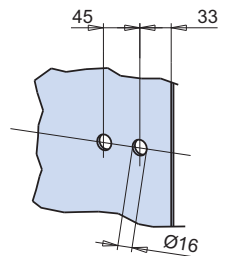
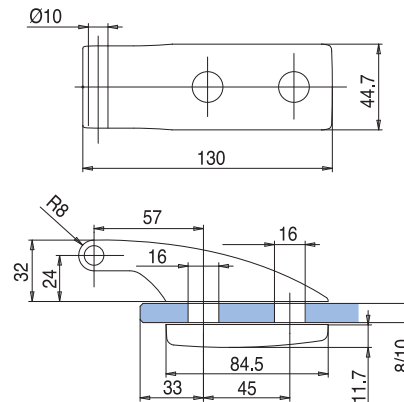

€ E.382

xla34



V-403 FERRARI

- Cerniera con aletta fissaggio per stipiti da 28mm.
- Side hinge with fixing plate for rebates of 28mm.
- Band mit Anschraubplatte für Falztiefe 28mm.

AN - CS - NS - CR - CP - OL

€ ▶ E.384

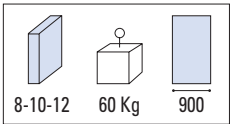
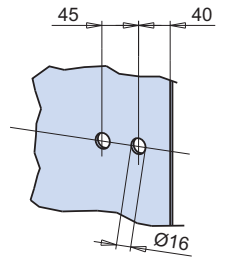
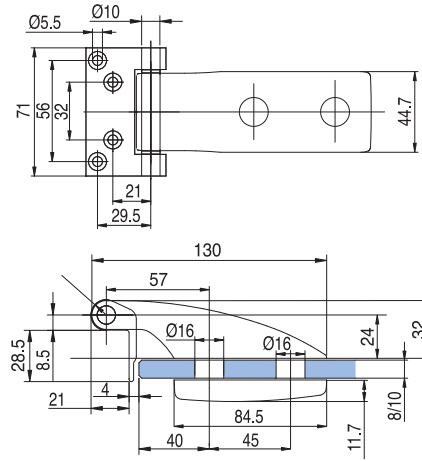

xme013



V-102 ONE

- Cerniera tipo tedesco.
- Side hinge German type.
- 2-teiliges Band einschl. Hülse.

CS - NS - CR - OL

€ ▶ E.383

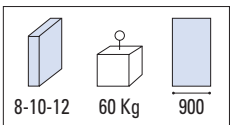
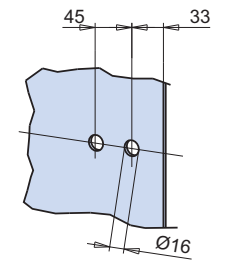
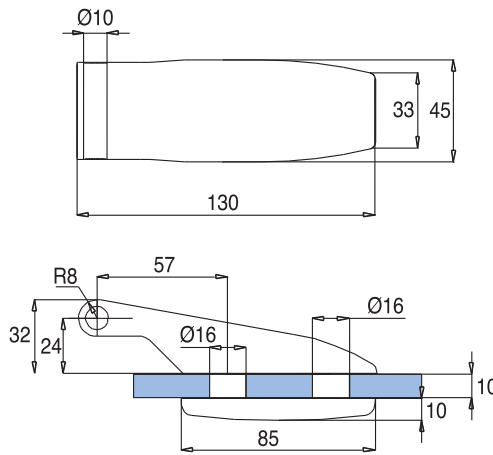

xla188



L-220

- Cerniera a scatto vetro/vetro, senza viti in vista. Materiale: Zamak.
- Glass to glass clicking hinge, with not visible screws. Material: Zamak.
- Duschtürband Glas-Glas ohne sichtbaren Schrauben. Material: Zamak.

CR - NS - CP

€ ▶ B.215

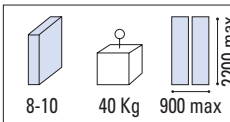
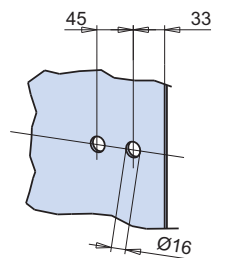
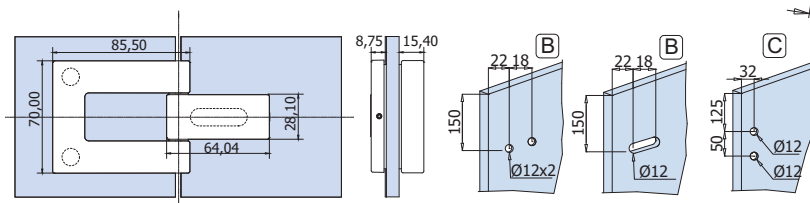

- B = Lavorazione vetro alternativa
- Alternative glass preparation
- Alternativ Glasbearbeitung

xme403

CERNIERE

CERNIERE AUTOMATICHE

AUTOMATIC HINGES / AUTOMATISCHE BÄNDER



V-508

- Cerniera automatica con apertura 180°
- Automatic hinge with opening 180°
- Automatisches Pendeltürband mit Öffnung 180°

NS - CR - CS - CP - OL

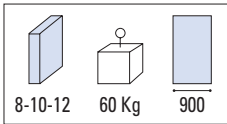
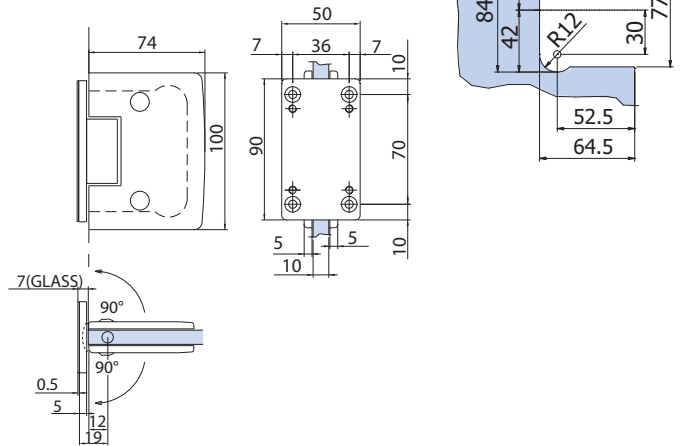

€▶ E.387

xla37



V-516

- Cerniera automatica vetro/vetro con apertura 180°
- Automatic hinge glass to glass with opening 180°
- Automatisches Pendeltürband Glas-Glas mit Öffnung 180°

NS - CR - CS - CP - OL

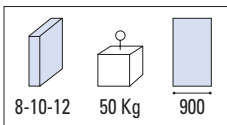
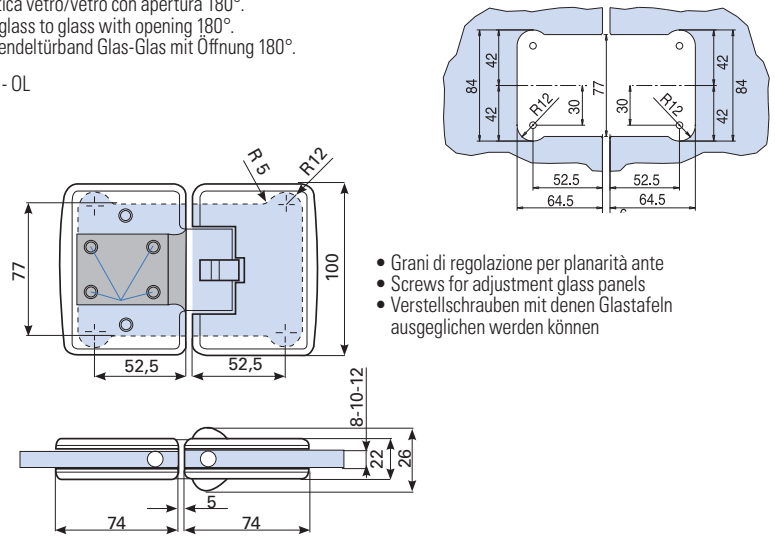

€▶ E.387

- Grani di regolazione per planarità ante
- Screws for adjustment glass panels
- Verstellschrauben mit denen Glastafeln ausgeglichen werden können

xla37



V-908

- Cerniera automatica con apertura 180°
- Automatic hinge opening 180°
- Automatisches Pendeltürband mit Öffnung 180°

NS - CP - CR

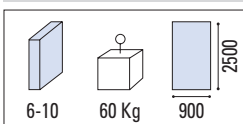
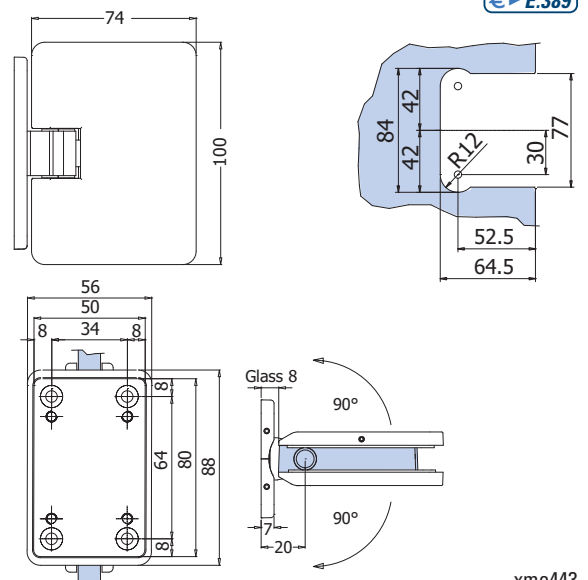

€▶ E.389

xme443

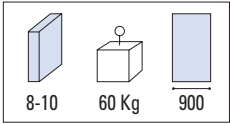

V-508 AS

- Cerniera automatica con apertura 180°, con aletta spostata
- Automatic hinge opening 180°, with side fixing plate
- Automatisches Pendeltürband mit Öffnung 180°, mit einseitiger Anschraubplatte

NS

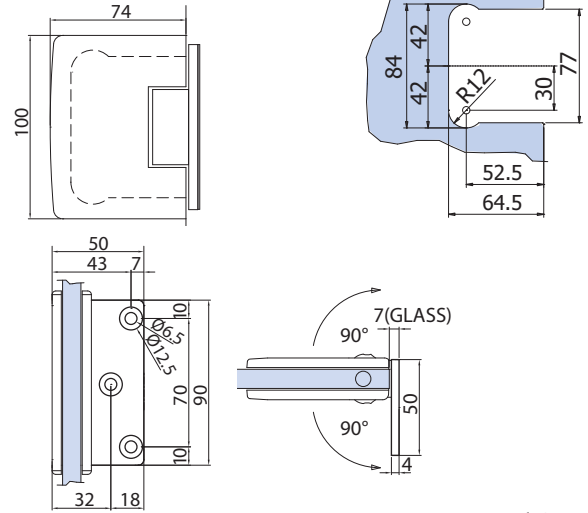

€ E.388

xla37as



ND
Patent Pending

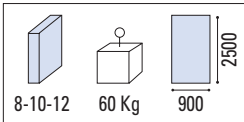

V-908 AS

- Cerniera automatica con apertura 180°, con aletta spostata
- Automatic hinge opening 180°, with offset fixing plate
- Automatisches Pendeltürband mit Öffnung 180°, mit einseitiger Anschraubplatte

NS - CP - CR

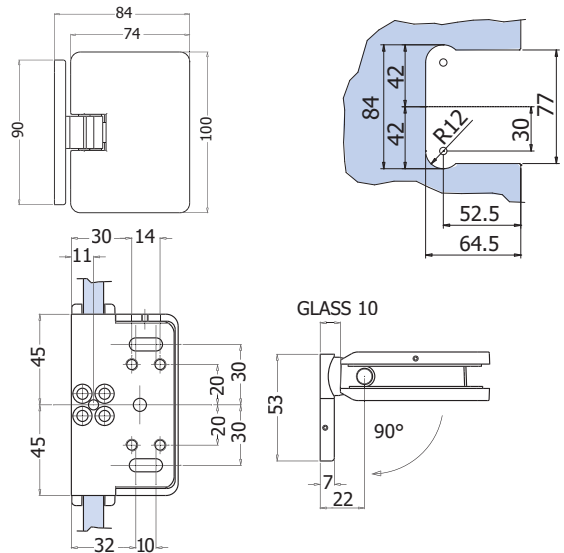

€ E.389

xfb116

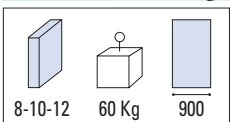

V-507

- Cerniera automatica chiusura a 90° per porte in battuta, profondità stipite 28 mm.
- Automatic hinge closing at 90° for doors with stop frame, rebate depth 28 mm.
- Anschlagtürbänder mit selbstschließender Mechanik, für Falztiefe 28 mm.

NS - CR - CS - CP - OL

V-507-A

V-507-B

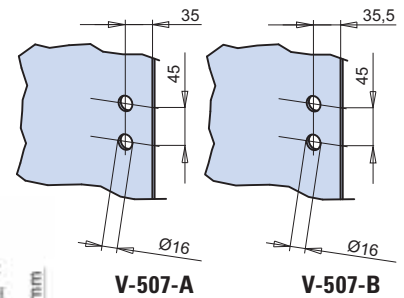
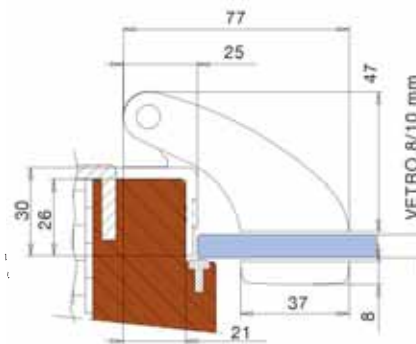

€ E.390

xla47

CERNIERE OLEODINAMICHE

HYDRAULIC HINGES / HYDRAULIKBAND

€ E.392



V-808

- Cerniera oleodinamica con regolazione della velocità di chiusura dell'anta, stop a 0° +90° -90°.
- Hydraulic hinge with adjustment of the closing speed, stop at 0° +90° -90°.
- Hydraulikband mit Einstellung der Türschließgeschwindigkeit stop zu 0° +90° -90°.

NS - CR - AN

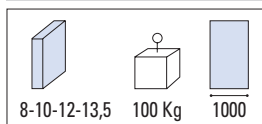
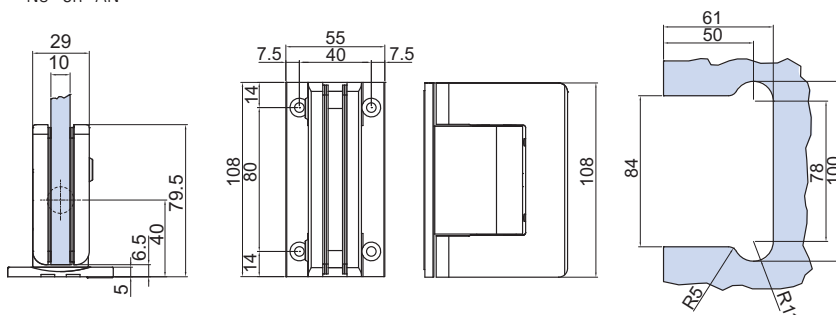

- Valvola di regolazione velocità chiusura anta
- Adjustment valve closing speed of door
- Regelsventil für die Türschließgeschwindigkeit

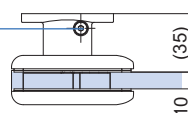

xme499-A

€ E.392



V-808-AS

- Cerniera oleodinamica con regolazione della velocità di chiusura dell'anta (con alletta spostata), stop a 0° +90° -90°.
- Hydraulic hinge with adjustment of the closing speed, (with offset fixing wing), stop at 0° +90° -90°.
- Hydraulikband mit Einstellung der Türschließgeschwindigkeit (einseitige Anschraubplatte) stop zu 0° +90° -90°.

NS - CR - AN

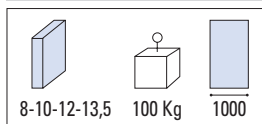
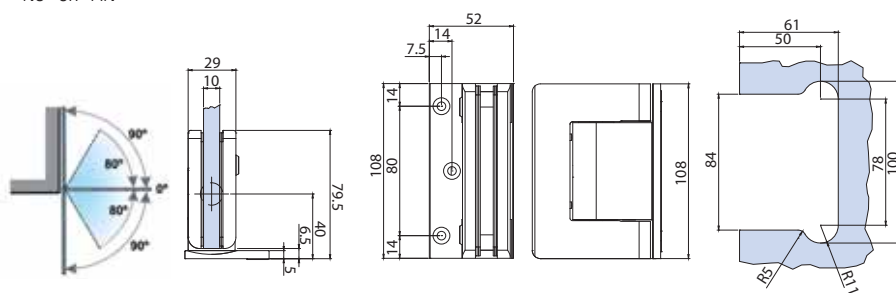

- Valvola di regolazione velocità chiusura anta
- Adjustment valve closing speed of door
- Regelsventil für die Türschließgeschwindigkeit

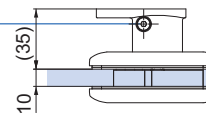

xme499-B

€ E.392



V-816

- Cerniera oleodinamica vetro/vetro 180° con regolazione della velocità di chiusura dell'anta, stop a 0° +90° -90°.
- Hydraulic hinge (glass/glass) 180° with adjustment of the closing speed, stop at 0° +90° -90°.
- Hydraulikband (Glas-Glas) 180° mit Einstellung der Türschließgeschwindigkeit stop zu 0° +90° -90°.

NS - CR - AN

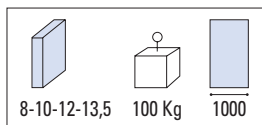
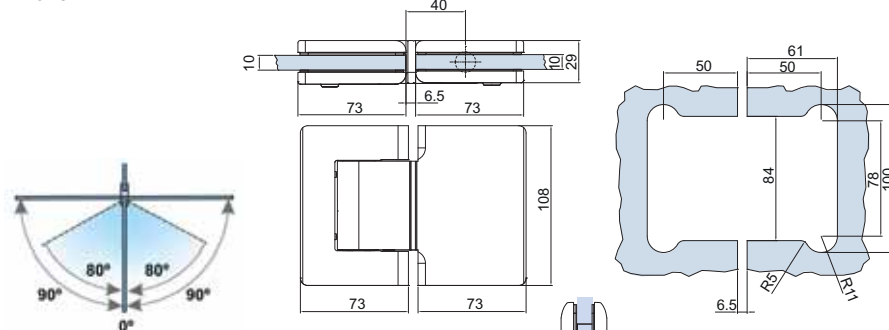

- Valvola di regolazione velocità chiusura anta
- Adjustment valve closing speed of door
- Regelsventil für die Türschließgeschwindigkeit

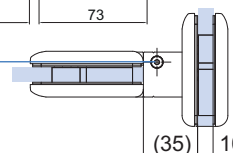

xme499-C

CERNIERE



V-808-R

€ E.395

- Cerniera oleodinamica con regolazione della velocità di chiusura dell'anta e regolazione del punto 0.
- Corpo interno anodizzato e copertina esterna in acciaio inox AISI 316. Stop a 0° + 90° - 90°.
- Hydraulic hinge with adjustment of the closing speed and zero point adjustability.
- Inner body is anodized and cover made of stainless steel AISI 316. Stop at 0° + 90° - 90°.
- Hydraulikband mit Einstellung der Türschließgeschwindigkeit und 0°-Punkt-Regulierung.
- Der innere Körper ist eloxiert Abdeckung aus Edelstahl AISI 316. Stop zu 0° + 90° - 90°.

IX - IL

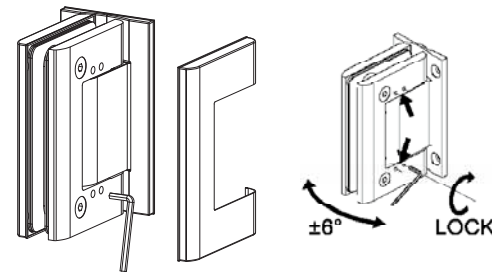
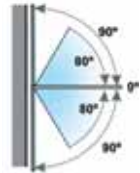
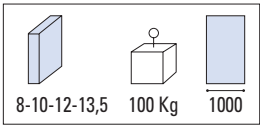
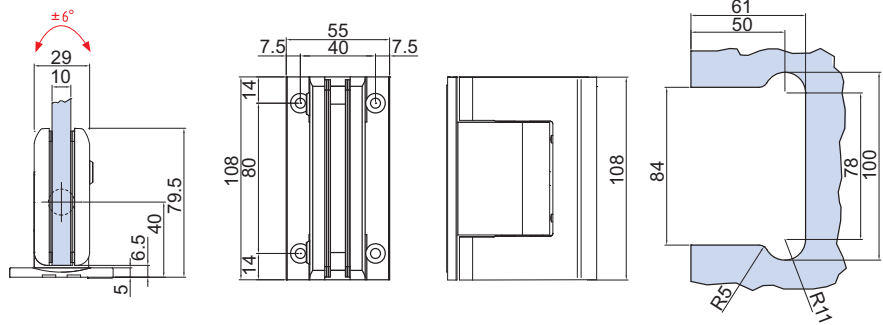

- Valvola di regolazione velocità chiusura anta
- Adjustment valve closing speed of door
- Regelsventil für die Türschließgeschwindigkeit

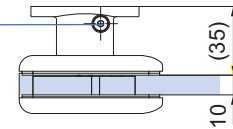

xme499-D



V-816-R

€ E.396

- Cerniera oleodinamica vetro/vetro 180° con regolazione della velocità di chiusura dell'anta e regolazione del punto 0.
- Corpo interno anodizzato e copertina esterna in acciaio inox AISI 316 Stop a 0° + 90° - 90°.
- Hydraulic hinge (glass/glass) 180° with adjustment of the closing speed and zero point adjustability.
- Inner body is anodized and cover made of stainless steel AISI 316. Stop at 0° + 90° - 90°.
- Hydraulikband (Glas-Glas) 180° mit Einstellung der Türschließgeschwindigkeit und 0°-Punkt-Regulierung.
- Der innere Körper ist eloxiert Abdeckung aus Edelstahl AISI 316. Stop zu 0° + 90° - 90°.

IX - IL

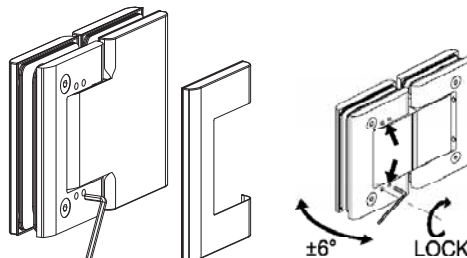
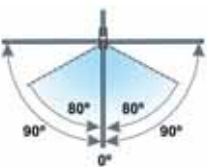
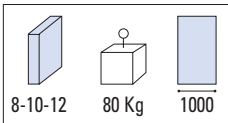
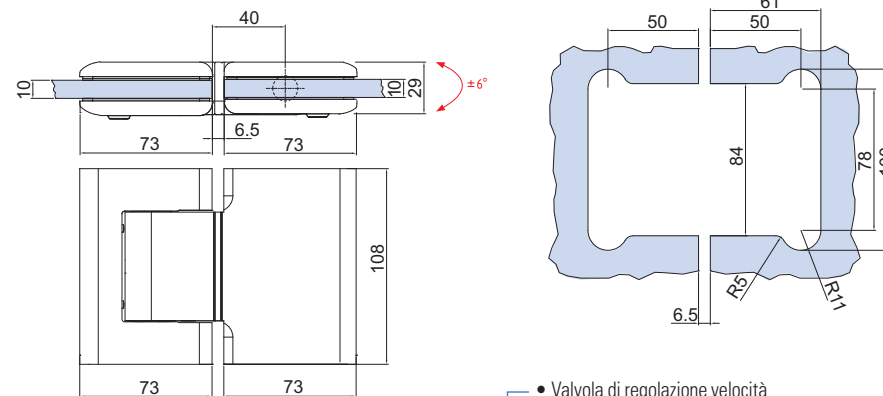

- Valvola di regolazione velocità chiusura anta
- Adjustment valve closing speed of door
- Regelsventil für die Türschließgeschwindigkeit

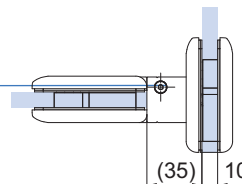

xme499-E

V-807



V-807 AN



- Cerniera oleodinamica con regolazione della velocità di chiusura dell'anta, per porte in battuta. Profondità stipite 40 mm. Ideale per chiusure ermetiche. Stop a 0° +90°
- Hydraulic hinge with adjustment of the closing speed glazes of the door with stop. Rebate depth 40 mm. Ideal for hermetic closing. Stop at 0° +90°.
- Automatik-Hydraulikscharnier mit Regulierung der Schließgeschwindigkeit der Tür. Für Anschlagtüren geeignet, für Falztiefe 40 mm. Ideal für hermetische Schließung Feststellung bei 0° +90°



V-807 CR € E.397



V-807 NS € E.397

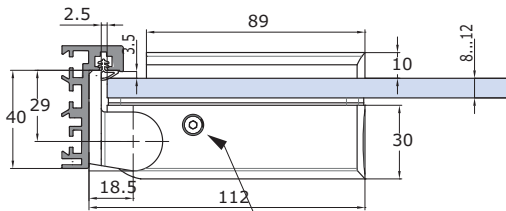
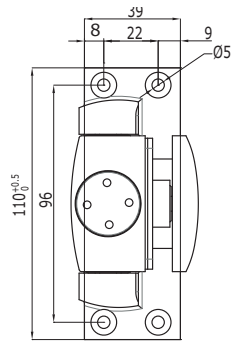

- Valvola di regolazione velocità chiusura anta
- Adjustment valve closing speed of door
- Regelsventil für die Türschließgeschwindigkeit

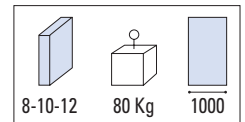
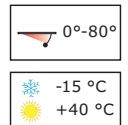
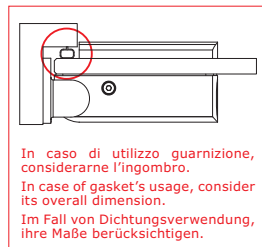
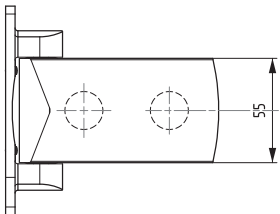
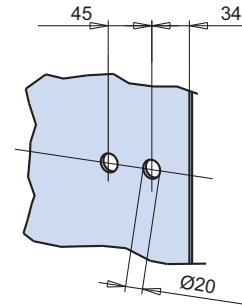

xme516

€ E.398

P-066

- Aletta optional per montaggio cerniera V-807 su stipite P-080-SL senza lavorazioni.
- Optional fixing plate for hinge V-807 for door frame P-080-SL without profile preparation.
- Optional Befestigungsplatte für Band V-807 für Anschlagtürzarge P-080-SL ohne Profilbearbeitung.

P-080-SL

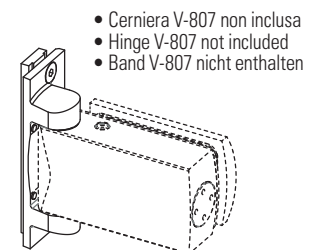
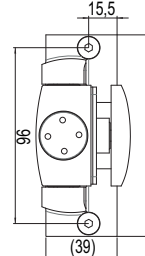
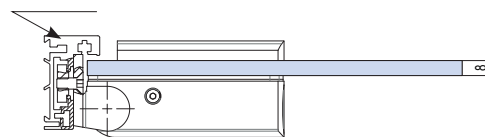

xru004

AN
Alluminio anodizzato
Aluminium anodized
Aluminium Silberfarbig

NS
Nickel satinato
Satin nickel
Ähnlich Edelstahl matt

CR
Cromo lucido
Polished chrome
Chrom glänzend

CERNIERE INFERIORI OLEODINAMICHE

HYDRAULIC BOTTOM HINGES / HYDRAULISCHE UNTERE BÄNDER



CERNIERE

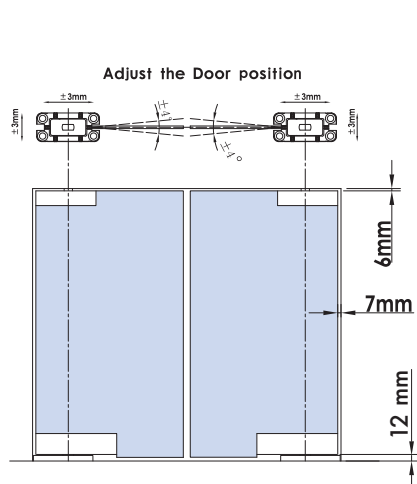

- Regolazione valvola velocità
- Speed adjusting valve
- Regelsventil

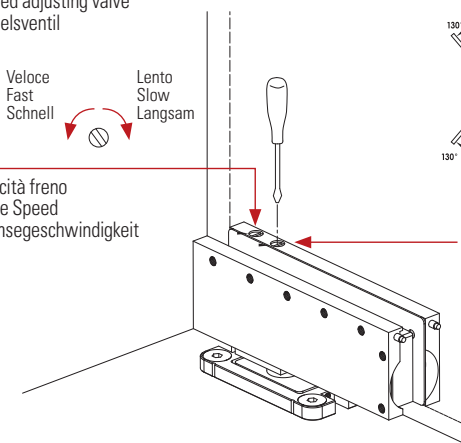

- Velocità freno
- Brake Speed
- Bremsengeschwindigkeit

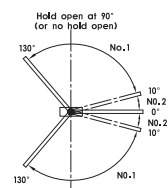

- Fermo aperto a 90°
 (o senza fermo)
- Hold open at 90°
 (or no hold open)
- Feststellung geöffnet 90°
 (oder ohne Feststellung)

- Velocità chiusura
- Closing Speed
- Türschließgeschwindigkeit



LAM-H1006

€ G.01

- Cerniera inferiore oleodinamica con chiudiporta integrato, stop a 0° +90° -90°.
- Hydraulic bottom hinge with integrated door closer stop at 0° +90° -90°.
- Unteres Hydraulikband mit Einstellung der Türschließgeschwindigkeit Stop zu 0°, +90°, -90°.

IX-AN

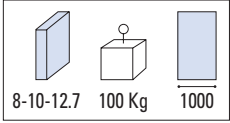
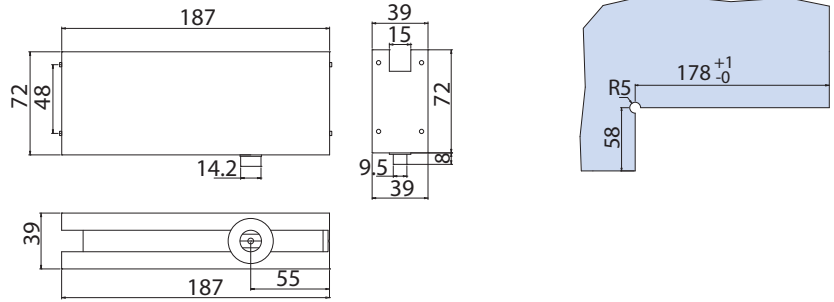

xme338



LAM-H1007

€ G.05

- Cerniera inferiore oleodinamica con chiudiporta integrato, stop a 0° +90° -90°.
- Hydraulic bottom hinge with integrated door closer stop at 0° +90° -90°.
- Unteres Hydraulikband mit Einstellung der Türschließgeschwindigkeit Stop zu 0°, +90°, -90°.

IX

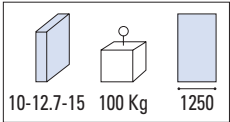
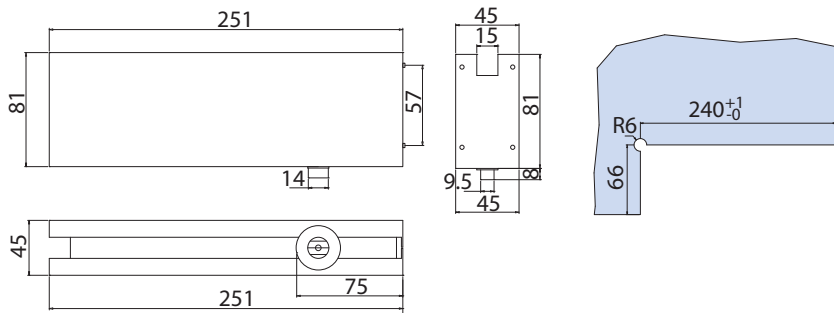

xme338



LAM-H1008

€ G.02

- Cerniera superiore registrabile con copertine di misure come LAM-H1006.
- Top patch adjustable with cover plate's size same as LAM-H1006.
- Oberer Eckbeschlag, Abdeckungen wie LAM-H1006 mit verstellbarem Lager.

IX-AN

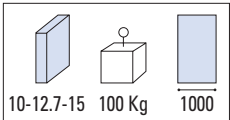
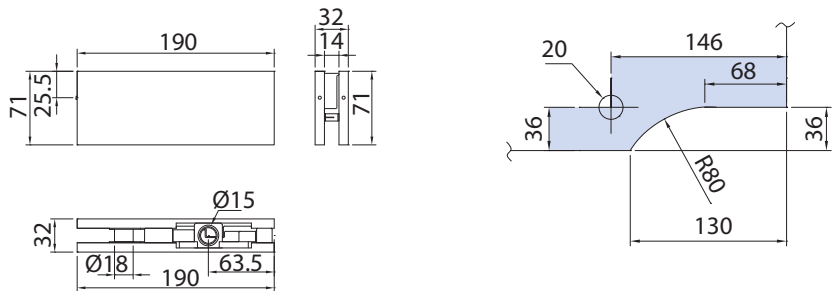

xme381



LAM-H1000

€ B.215

- Perno superiore per LAM-H1008.
- Top pin for LAM-H1008.
- Oberer Zapfen für LAM-H1008.

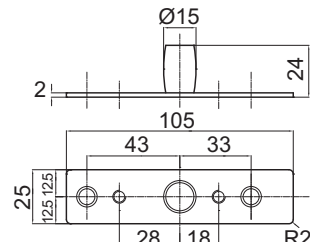

xla117

CERNIERE

CERNIERE OLEODINAMICHE "OLLY" HYDRAULIC HINGES "OLLY" / HYDRAULISCHE BÄNDER "OLLY"



V-H1012

€ ▶ G.06

- Cerniera inferiore oleodinamica con chiudiporta integrato, stop a 0° +90° -90°.
- Hydraulic bottom hinge with integrated door closer stop at 0° +90° -90°.
- Unteres Hydraulikband mit Einstellung der Türschließgeschwindigkeit Stop zu 0°, +90°, -90°.

IX

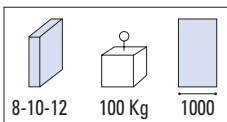
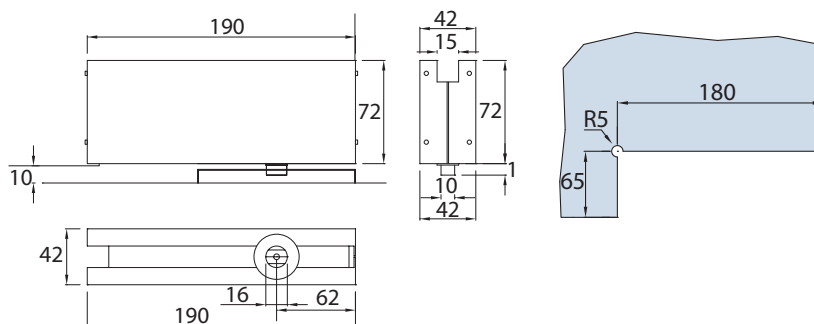

xme560



V-H1013

€ ▶ G.07

- Cerniera superiore registrabile con copertine di misure come LAM-H1012, perno superiore incluso
- Top patch adjustable with cover plate's size same as LAM-H1012, top pin included
- Oberer Eckbeschlag, Abdeckungen wie LAM-H1012 mit verstellbarem Lager, oberer Zapfen enthalten

IX

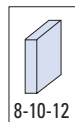
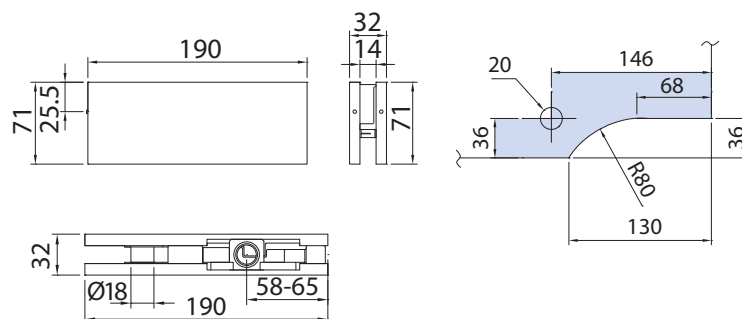

xme381



CONTROPIASTRE

STRIKE PLATE / SCHLISSBLECH



- CP-015**
- Contropiastrea **universale** per tutte le serrature meccaniche
 - Universal** strike plate for all the mechanical locks
 - Schliessblech für alle mechanische Schlösser

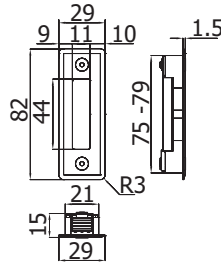

xla241

- CP-015 M**
- Contropiastrea **universale** per tutte le serrature magnetiche
 - Universal** strike plate for all the magnetic locks
 - Schliessblech für alle magnetische Schlösser



- V-037**
- Contropiastrea per stipiti con profondità 40 mm art:
 - Flat strike plate for frames with depth 40 mm:
 - Schließblech für Türzargen mit Falztiefe 40mm: P-030 / P-040 / TP-300 / TP-250 / P-080 / TP-201 TP-401 / TP-100 / TP-110

IX

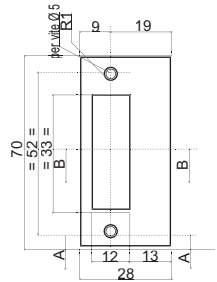

SB-252

- Per serrature / For locks
- Für Schlösser: V-900 / V-540 / V-230 V-730 / V-200 / V-720 V-400



- CP-01**
- Contropiastrea **piatta universale**.
 - Flat strike plate **universal**.
 - Schließblech **universal**.

AN

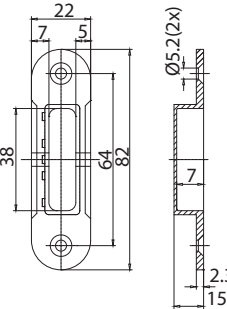

xla241

- Per serrature / For locks
- Für Schlösser: V-900 / V-540 / V-230 UV V-730 UV / V-200 UV V-720 UV / V-400 UV V-750 / V-780



- V-022**
- Contropiastrea per serrature con gancio per scorrevole
 - Flat strike plate for lock with hook sliding
 - Schließplatte für Schlösser mit Hakenfalle CS - NS - CR

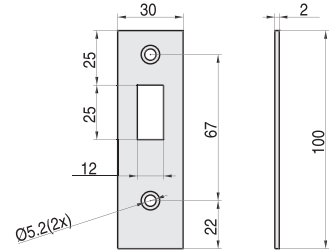

xla132

- Per serrature / For locks
- Für Schlösser: V-724 / V-744 / V-734 V-504 NC / V-518 / V-554 NC



- V-002**
- Contropiastrea **piatta**
 - Flat strike plate
 - Schliessplatte. CR

CR

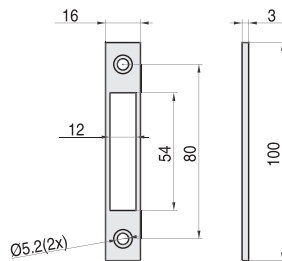

xla132

- Per serrature / For locks
- Für Schlösser: V-900 / V-540 / V-230 V-730 / V-200 / V-720 V-400 / V-726 / V-746 V-736 / V-515 / V-520 V-555



- V-023**
- Contropiastrea per serrature con perno Ø 10 mm
 - Flat strike plate for locks with rounded dead bolt Ø 10 mm
 - Schliessplatte für Schlösser mit Bolzen Ø 10 mm CS - NS - CR

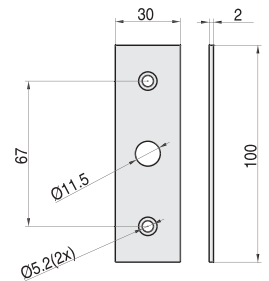

xla132

- Per serrature / For locks
- Für Schlösser: V-725 / V-745 / V-735 V-505 / V-519 / V-557



- V-020**
- contropiastrea per stipiti con profondità da 40 mm
 - strike plate for frames with depth of 40 mm
 - Winkelschließblech für Falztiefe 40 mm. CS - NS - CR - OL

CS - NS - CR - OL

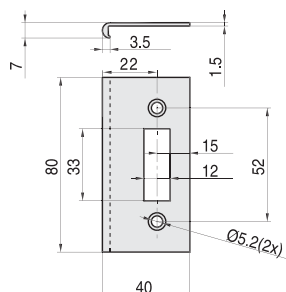

xla132

- Per serrature / For locks
- Für Schlösser: V-900 / V-540 / V-230 V-730 / V-200 / V-720 V-400 / V-750



- V-021**
- Contropiastrea per stipite con profondità da 28 mm e vetro 8 mm
 - Strike plate for rebates of 28 mm and glass 8 mm
 - Winkelschließblech für Falztiefe 28mm und Glas 8 mm CS - NS - CR - OL

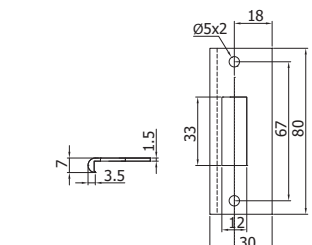

xme 169

- Per serrature / For locks
- Für Schlösser: V-900 / V-540 / V-230 V-730 / V-200 / V-720 V-400



V-031

€ E.297

- Contropiastra per battuta a muro e vetro da 10 mm
 - Wall strike plate with glass 10 mm
 - Winkelschließblech Wand befestigung mit Glas 10 mm
- AN - CS

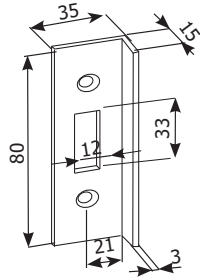

SB-252

- Per serrature / For locks
- Für Schlösser:
- V-900 / V-540 / V-230
- V-730 / V-200 / V-720
- V-400



V-931

€ E.297

- Contropiastra per battuta a muro per serratura V-900 e V-540.
 - Wall strike plate for lock V-900 and V-540.
 - Wand Schließblech mit Anschlag für Schloss V-900 und V-540.
- NS - AN

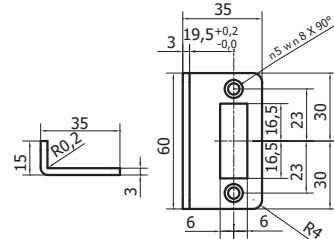

259P035

- Per serrature / For locks
- Für Schlösser:
- V-900 / V-540 / V-230
- V-730 / V-200 / V-720
- V-400



V-032

€ E.299

- Contropiastra piatta per stipiti e profondità da 48 mm
 - Strike plate for rebates 48 mm
 - Schließplatte für Falztiefe 48 mm
- CS - CR

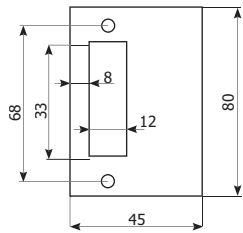

- Per serrature / For locks
- Für Schlösser:
- V-900 / V-540 / V-230
- V-730 / V-200 / V-720
- V-400



V-033

€ E.300

- Contropiastra per stipite con profondità da 28 mm. per serrature art. V-200 / V-400 / V-600 / V-700 / V-720 montate su vetro da 10 mm
 - Strike plate for rebates of 28 mm for locks art. V-200 / V-400 / V-600 / V-700 / V-720 with glass 10 mm
 - Winkelschließblech für schlösser V-200 / V-400 / V-600 / V-700 / V-720 mit Falztiefe 28 mm und Glas 10 mm
- IX

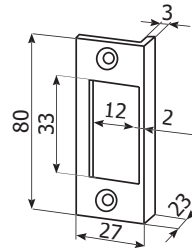

- Per serrature / For locks
- Für Schlösser:
- V-900 / V-540 / V-230
- V-730 / V-200 / V-720
- V-400



CP-04

€ E.302

- Contropiastra con battuta a muro per serratura V-750
 - Wall strike plate for lock V-750
 - Wandschließblech mit Anschlag für Schloss V-750
- AN

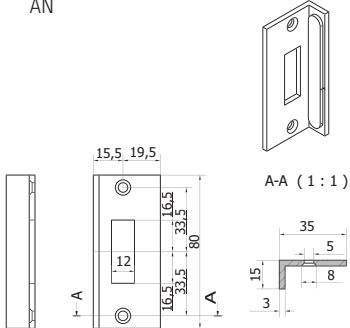

136P035

- Per serrature / For locks
- Für Schlösser:
- V-564 / V-565 / V-584
- V-585 / V-594 / V-574
- V-575



V-568

€ E.303

- Contropiastra piatta per serrature Minima 55
 - Flat strike plate for locks Minima 55
 - Flach Schließblech für Schlösser Minima 55
- IX

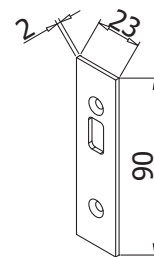

xme496-f

- Per serrature / For locks
- Für Schlösser:
- V-564 / V-565 / V-584
- V-585 / V-594 / V-574
- V-575



V-567-DX

€ E.304

- Contropiastra destra con battuta a muro per serrature Minima 55, assemblabile anche con contro serratura V-569 2FLG
 - Wall strike plate right with rebate for locks Minima 55, available for installing with strike box V-569 2FLG
 - Schließblech rechts mit Anschlag Wandmontage für Schlösser Minima 55, montierbar mit Gegenkasten V-569 2FLG
- AN

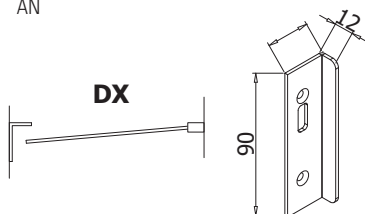

xme496-f

- Per serrature / For locks
- Für Schlösser:
- V-564 / V-565 / V-584
- V-585 / V-594 / V-574
- V-575



V-567-SX

€ E.304

- Contropiastra sinistra con battuta a muro per serrature Minima 55, assemblabile anche con contro serratura V-569 2FLG
 - Wall strike plate left with rebate for locks Minima 55, available for installing with strike box V-569 2FLG
 - Schließblech links mit Anschlag Wandmontage für Schlösser Minima 55, montierbar mit Gegenkasten V-569 2FLG
- AN

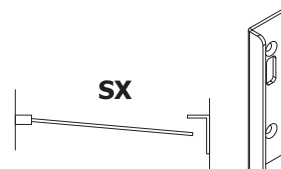

xme496-f

- Per serrature / For locks
- Für Schlösser:
- V-564 / V-565 / V-584
- V-585 / V-594 / V-574
- V-575



CP-010

E.307

- Contropiastra magnetica per serrature magnetiche tipo: MV-790 PZ / MV-791 PZ
 - Magnetic strike plate for magnetic locks: MV-790 PZ / MV-791 PZ
 - Magnetisches schliessblech für magnetische Schlösser: MV-790 PZ / MV-791 PZ
- AN

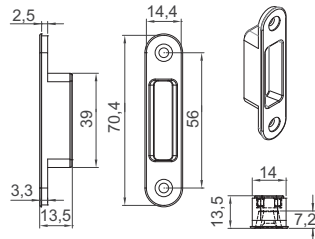

CP-011

E.308

- Contropiastra magnetica regolabile tramite le 2 viti per serrature magnetiche tipo: MV-100/MV-200/ MV-400/MV-720
 - Magnetic strike plate adjustable through front screws for magnetic locks: MV-100/MV-200/MV-400/MV-720
 - Magnetisches Schliessblech erstellbar durch vorderen Schrauben für magnetische Schlösser. MV-100/MV-200/ MV-400/MV-720
- AN

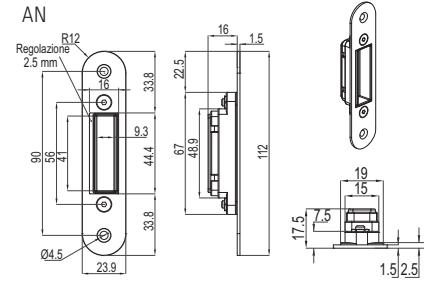

C-012

E.309

- Contropiastra magnetica per MV-750
 - Magnetic strike plate for lock MV-750
 - Magnetisches Schließblech für Schloss MV-750 standard inkl.
- CP

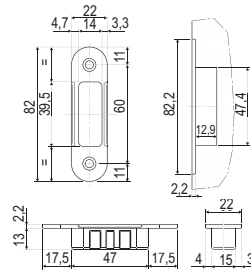

C-013

E.310

- Contropiastra magnetica per MV-750 per stipiti in alluminio
- Magnetic strike plate for lock MV-750 with aluminium door jambs profiles
- Magnetisches Schließblech für Schloss MV-750 mit Aluzarge.

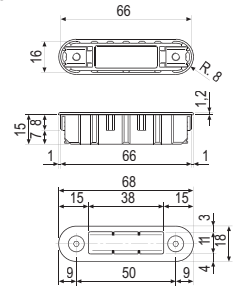

CP-05

E.305

- Incontro elettrico per serratura V-750 AC/DC 12 volts.
 - Electric strike plate for lock V-750 AC/DC 12 volts.
 - Elektrisches Schließblech für Schloss V-750 AC/DC 12 volt.
- AN

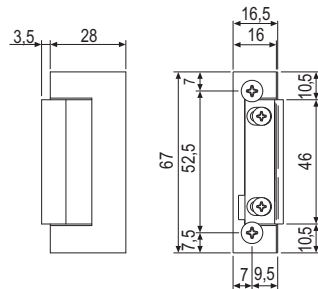

CP-06

E.306

- Incontro elettrico ad angolo per serratura V-750 AC/DC 12 volts.
 - Electric angled strike plate for lock V-750 AC/DC 12 volts.
 - Elektrisches Winkelschließblech für Schloss V-750 AC/DC 12 volt
- AN

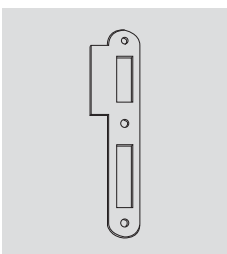
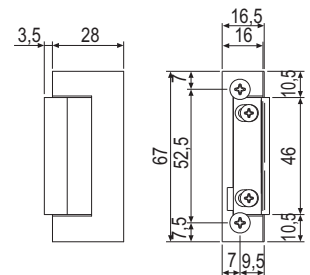

CP-02 L (sinistra / left / links)
CP-02 R (destra / right / Recht)

E.301

- Contropiastra destra e sinistra per serratura verticale V-770
 - Strike plate right and left for vertical lock V-770
 - Schließblech Rechts und links für Schloss V-770
- AN



GEMMERE

CILINDRI CYLINDERS / ZYLINDER



C-01 **E.311**

- Cilindro WC con pomolo per lato serratura.
 - WC cylinder with knob for lock side.
 - WC Zylinder mit Knopf auf Schlossseite.
- CS - NS - CR - OL

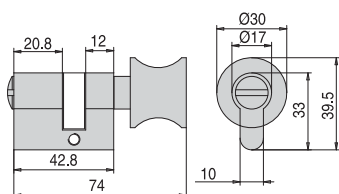

xla53



C-02 **E.312**

- Cilindro WC con pomolo per lato battuta.
 - WC cylinder with knob for rebate side.
 - WC Zylinder mit Knopf auf Schlossgegensseite.
- CS - NS - CR - OL

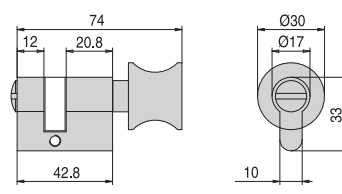

xla53



C-03 **E.313**

- Cilindro con doppio pomolo.
 - Cylinder with double knob.
 - Zylinder mit Doppelknopf.
- CS - NS - CR - OL

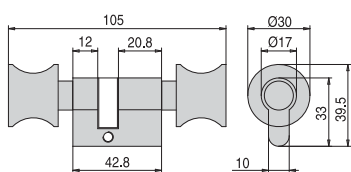

xla53



C-04 **E.314**

- Cilindro asimmetrico da 48 mm.
 - Cylinder asymmetrical with length 48 mm.
 - Zylinder unsymmetrisch mit Länge 48mm.
- CS

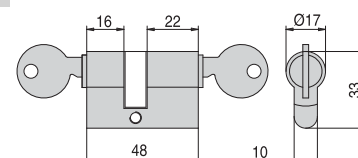

xla53



C-05 **E.315**

- Cilindro con pomolo e chiave.
 - Cylinder with knob and key.
 - Zylinder mit Knopf und Schlüssel.
- CS - NS - CR

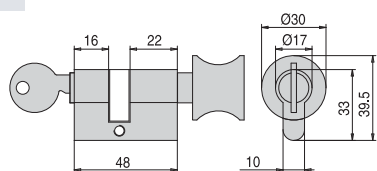

xla53



C-06 **E.316**

- Cilindro simmetrico da 45 mm.
 - Cylinder symmetrical length 45 mm.
 - Zylinder symmetrisch mit Länge 45mm.
- CR

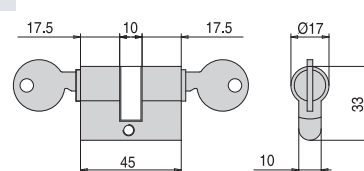

xla53



C-08 **E.318**

- Cilindro con pomolo e chiave mm 62.
 - Cylinder with knob and key length 62 mm.
 - Zylinder mit Knopf und Schlüssel Länge 62 mm.
- CS - NS - CR - OL - CP

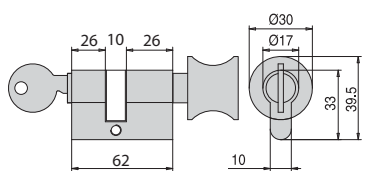

xla53



C-08-Q **E.319**

- Cilindro chiave/pomolo
 - Cylinder knob/key
 - Zylinder Knopf/Schlüssel
- CS - NS - CR - CP

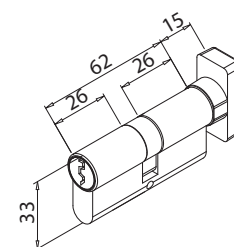

xla53



C-07 €▶ E.317

- Cilindro WC asimmetrico con 1 pomolo per chiusura porta ed 1 fisso per tirare anta.
- WC cylinder asymmetrical with double knob (1 with closing function, 1 fixed).
- WC-Zylinder unsymmetrisch mit Doppelknopf einmal mit Schließfunktion, CS - NS - CR - OL

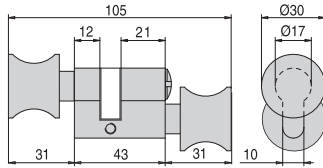

xla53



C-09 €▶ E.320

- Cilindro asimmetrico 61 mm.
- Cylinder asymmetrical with length 61 mm.
- Zylinder unsymmetrisch mit Länge 61 mm. CR

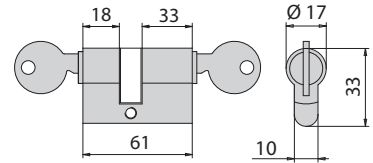

xla53



C-013 €▶ E.321

- Cilindro WC con pomolo.
- WC cylinder with knob.
- WC Zylinder mit Knopf. CS - NS - CP - CR

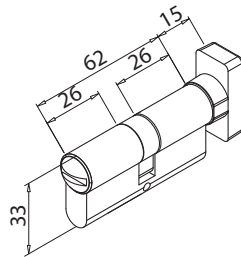

fb049-a-gr



C-014 €▶ E.322

- Cilindro simmetrico
- Cylinder symmetrical
- Zylinder symmetrisch CR

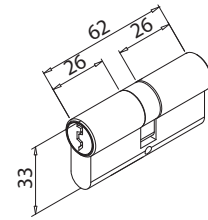

fb049-a-gr



C-016 €▶ E.323

- Cilindro W.C. asimmetrico, 1 pomolo chiusura porta, 1 pomolo fisso per tirare anta
- W.C. cylinder asymmetrical with double knob, 1 with closing function - 1 fixed
- WC Zylinder unsymmetrisch mit Doppelknopf (1 mit Schließfunktion, 1 ohne funktion) CS - NS - CR - CP

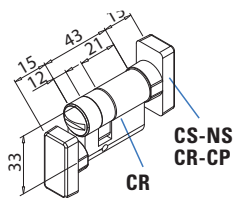

fb049-a-gr

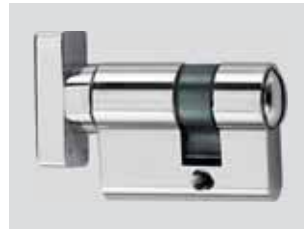

C-018 €▶ E.324

- Cilindro WC con pomolo per lato battuta.
- WC cylinder with knob for rebate side.
- WC Zylinder mit Knopf auf Schlossgegenseite. CS - NS - CR - CP

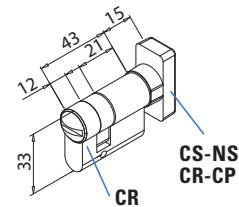

fb049-a-gr



C-023 €▶ E.325

- Cilindro chiave-chiave per serratura V-765 PZ
- Cylinder for lock V-765 PZ
- Zylinder für Schloss V-765 PZ CR

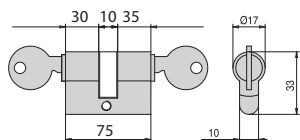

c-dualglass



C-024 €▶ E.326

- Cilindro simmetrico da 70 mm per serrature forti spessori V-745-13,5 / 17,5 / 21,5.
- Cylinder symmetrical length 70 mm for locks V-745-13,5 / 17,5 / 21,5.
- Zylinder symmetrisch mit Länge 70 mm für Schlösser V-745-13,5 / 17,5 / 21,5. CR

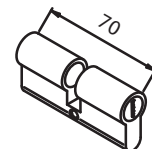

xme490



C-010 € E.327

- Cilindro ovale simmetrico per serrature V-564 / V-565 / V-574 / V-575
- Oval symmetrical cylinder for locks V-564 / V-565 / V-574 / V-575
- Ovaler Zylinder symmetrisch für Schlösser V-564 / V-565 / V-574 / V-575

CR

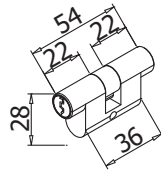

xme445



C-011 € E.328

- Cilindro W.C. ovale per serrature V-564 / V-565 / V-574 / V-575
- Oval W.C. cylinder for locks V-564 / V-565 / V-574 / V-575
- Ovaler WC Zylinder für Schlösser V-564 / V-565 / V-574 / V-575

CP - NS - CR

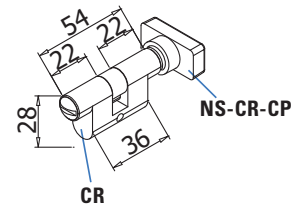

xme445



C-012 € E.329

- Cilindro ovale chiave / pomolo per serrature V-564 / V-565 / V-574 / V-575
- Oval cylinder knob / key for locks V-564 / V-565 / V-574 / V-575
- Ovaler Zylinder Knopf / Schlüssel für Schlösser V-564 / V-565 / V-574 / V-575

CP - NS - CR

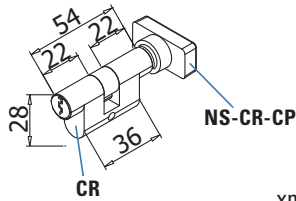

xme445

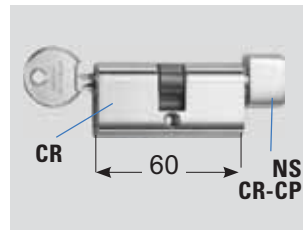

C-019 € E.330

- Cilindro ovale chiave / pomolo per serrature V-900 / V-780 / V-584 / V-585 / V-594
- Oval cylinder key / knob for locks V-900 / V-780 / V-584 / V-585 / V-594
- Ovaler Zylinder mit Knopf und Schlüssel für Schlösser V-900 / V-780 / V-584 / V-585 / V-594

CP - NS - CR

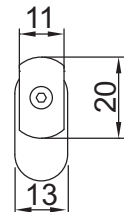

xla53

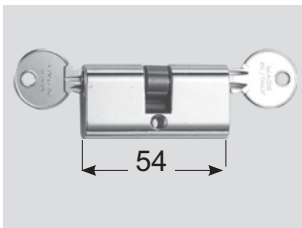

C-020 € E.331

- Cilindro ovale chiave/chiave per serrature V-900 / V-780 / V-584 / V-585 / V-594
- Oval cylinder key/key for locks V-900 / V-780 / V-584 / V-585 / V-594
- Ovaler Zylinder für Schlösser V-900 / V-780 / V-584 / V-585 / V-594

CR

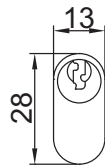

cilindri

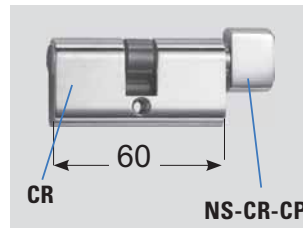

C-021 € E.332

- Cilindro ovale W.C. con pomolo per serrature V-900 / V-780 / V-584 / V-585 / V-594
- Oval W.C. cylinder with knob for locks V-900 / V-780 / V-584 / V-585 / V-594
- Ovaler WC Zylinder mit Knopf für Schlösser V-900 / V-780 / V-584 / V-585 / V-594

CP - NS - CR

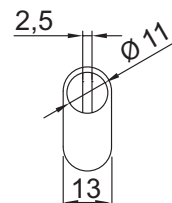

cilindri

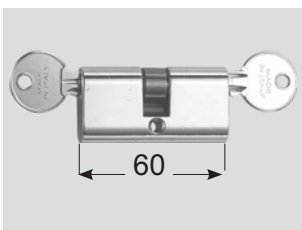

C-025 € E.333

- Cilindro ovale chiave/chiave per I-lock V-900 AN / V-900 IX
- Oval cylinder key/key for I-lock V-900 AN / V-900 IX
- Ovaler Zylinder für I-lock V-900 AN / V-900 IX

CR

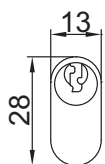

cilindri



C-022 € E.334

- Cilindro per MV-900 PZ
- Cylinder for MV-900 PZ
- Zylinder für MV-900 PZ

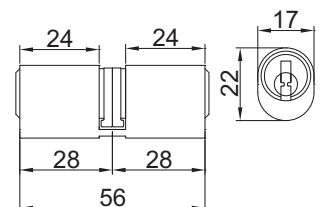

cilindri



ACCESSORI PER PORTE

ACCESSORIES FOR DOORS / ZUBEHÖRE

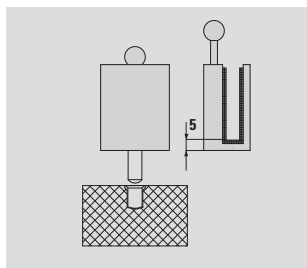

V-003-08
V-003-10 € E.336

- Catenacciolo per porta doppia, vetro 8 mm. o 10 mm
- Locking bolt down for double door glass 8 mm. or 10 mm.
- Feststeller für Glas 8 - 10 mm
CS - NS - CR - OL - CP

V-003

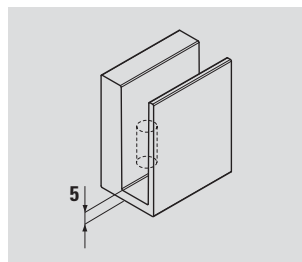

V-003-2FLG-08
V-003-2FLG-10 € E.338

- Catenacciolo per porta doppia, vetro 8 mm. o 10 mm
- Locking bolt down for double door glass 8 mm. or 10 mm.
- Feststeller für Glas 8 - 10 mm
CS - NS - CR - OL - CP

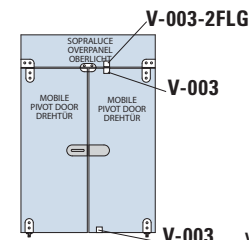

V-003-2FLG



V-004 € E.337

- Catenacciolo porta doppia.
- Locking bolt for double door.
- Türschnäpper für 2-flg
CS

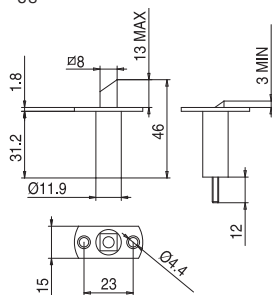

xla56b

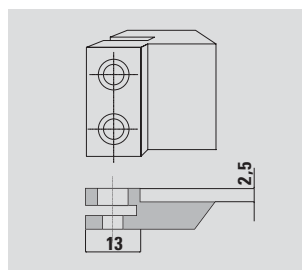

V-001 € E.339

- Scrocco fresato 2,5 mm. per serrature V-200 / V-200 ECO / V-400 / V-720
- Latch 2,5 milled for locks V-200 / V-200 ECO / V-400 / V-720
- Falle abgesetzt für Schlösser V-200 / V-200 ECO / V-400 / V-720

V-001 B

- Scrocco fresato per serrature V-230 / V-730
- Milled latch for locks V-230 / V-730
- Falle abgesetzt für Schlösser V-230 / V-730

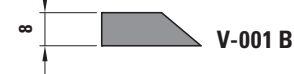

V-001



P-F07 € E.340

- Piastra di fissaggio cardini su stipiti legno norme tedesche DIN NORM.
- Admission for frame part wooden frame with four screws.
- Aufnahmeelement für Rahmenteil für Holzargen mit 4-fach Verschraubung.

xla53

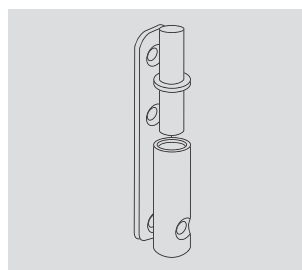

P-F01 € E.341

- Perno con piastra fissaggio per cerniere V-201, V-201 ECO, V-401, V-102.
- Pivot with fixing plate for hinges V-201, V-201 ECO, V-401, V-102.
- Aufschraub-rahmenteil für V-201, V-201 ECO, V-401, V-102 Bänder.

P-F01

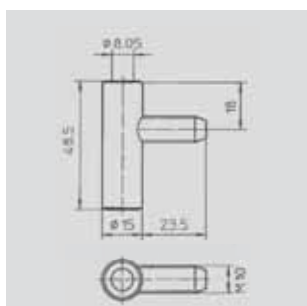

C-08 € E.318

- Cardine per stipiti metallici norme austriache, per cerniere V-402, V-702.
- Frame part for rebated doors on steel frame. Ready for use: For hinge V-402/V-702, german type - Load capacity: 70 kg
- Rahmenteil für Gefälzte türen an Ö-Norm Stahlargen. Einsatz: Für Glastürband V-402/V-702 verwendbar, 3teilige Bänder - Türgewicht: 70 kg

V-8000 1

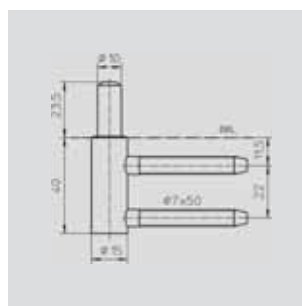

P-F02 € E.343

- Cardine per stipiti legno norme tedesche per cerniere V-201, V-401, V-201 eco, V-102
- Frame part for rebated doors on wooden frame Ready for use: for hinge V-201/V-401/V-201eco/V-102, german type - Load capacity: 70 kg
- Rahmenteil für Gefälzte türen an Holzargen DIN-NORM Einsatz: für Glastürband V-201/V-401/V-201eco/V-102 verwendbar, 2teilige Bänder - Türgewicht: 70 kg

V-3400WF

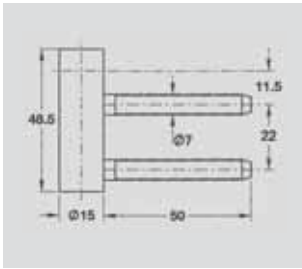

P-F03

€▶ E.345

- Cardine per stipiti legno norme tedesche DIN-NORM per cerniere V-402, V-702.
- Frame part for rebated door on wooden frame. Ready for use: for hinge V-402/V-702 german type. Load capacity: 70 kg
- Rahmenteil für Gefälzte türen an Holzargen. Einsatz: für Glastürband V-402/V-702 verwendbar, 3teilige Bänder - Türgewicht: 70 kg

v-4400 graf

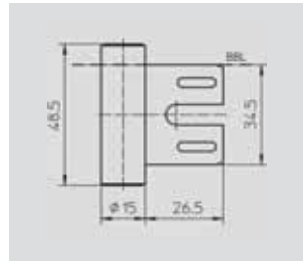

P-F04

€▶ E.344

- Cardine per stipiti metallici norme tedesche DIN-NORM per cerniere V-402, V-702
- Frame part for rebated door on steel frame. Ready for use: For hinge V-402/V-702 economy, german type
- Rahmenteil für Gefälzte türen an DIN-NORM Stahlargen Einsatz: Für Glastürband V-402/V-702 verwendbar, 3teilige Bänder - Türgewicht: 70 kg

V-8000 1 graf



01999

€▶ E.346

- Fermaporta Ø 57,2 mm. x 25 h
- Door stopper Ø 57,2 mm. x 25 h
- Türstopper Ø 57,2 mm. x 25 h IX

xla56b



02002

€▶ E.347

- Fermaporta Ø 32 X 37 h
- Door stopper Ø 32 mm. x 37 h
- Türstopper Ø 32 X 37 h IX

V-001



L-111

€▶ E.349

- Pozzetto eccentrico a pavimento
- Eccentric floor socket
- Exzenterbuchse verstellbar CS

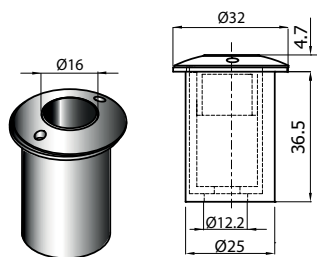

L-111 graf



L-112

€▶ E.348

- Pozzetto eccentrico a pavimento con tappo a molla antipolvere
- Eccentric floor socket with spring and dust cover
- Exzenterbuchse verstellbar mit Schutzabdeckung CS

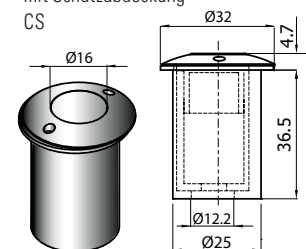

L-112.AI



L-112-PA

€▶ C.06

- Pozzetto eccentrico a pavimento con tappo a molla antipolvere per sistemi a parcheggio
- Eccentric floor socket with spring and dust cover for parking system
- Exzenterbuchse verstellbar mit Schutzabdeckung für Ganzglas-Schiebewandssysteme CS

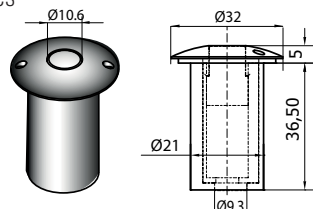

L-112-PA



V-026

€▶ E.351

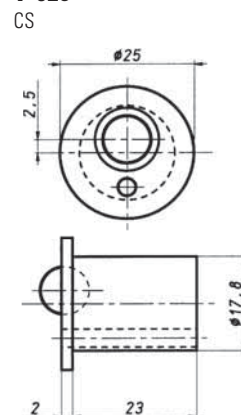

xla144

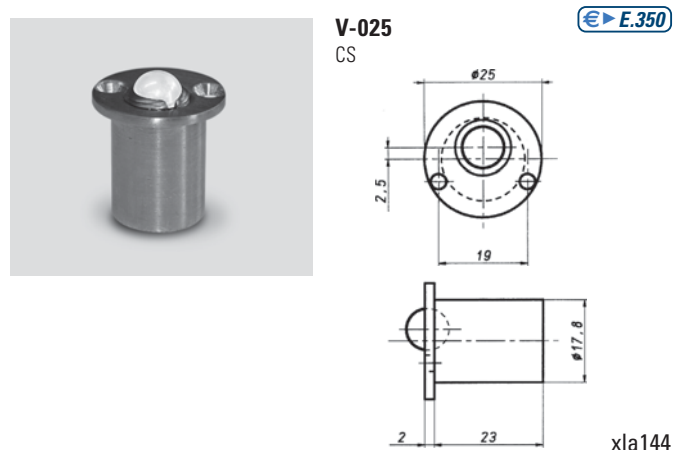
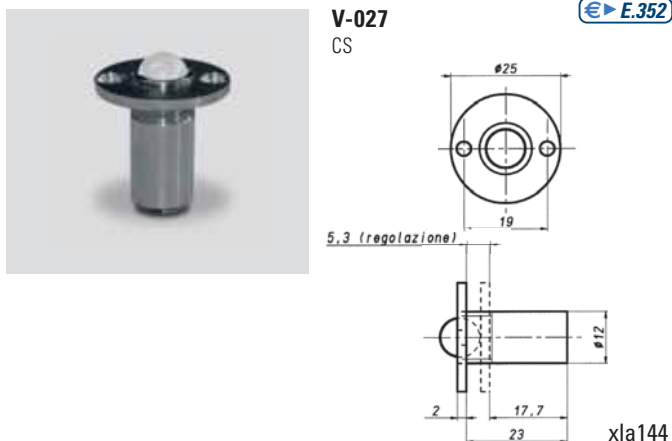

ACCESSORI PER VETRINE ACCESSORIES FOR DISPLAY CABINETS / ZUBEHÖRE FÜR SCHAUFENSTERAUSLAGE





CERNIERE

MANIGLIE MANIGLIONI POMOLI
DOORHANDLES PULLHANDLES KNOBS
TÜRGRIFFE STOSSGRIFFE KNÖPFE

F

F

GUIDA TECNICA PER LA SCELTA DEL VOSTRO SISTEMA

TECHNICAL GUIDE FOR THE CHOICE OF YOUR SYSTEM
 AUSWAHL VON SYSTEME NACH VORHANDENEN KRITERIEN

MANIGLIE DOORHANDLES TÜRGRIFFE

V-1711
Morphos
▶ 154



V-1651
Dune
▶ 154



V-1611
BLADE
▶ 154



V-1731
ELEKTRA
▶ 154



V-1721
PRESO
▶ 154



V-1762
RATIO
▶ 154



V-1671
LE MANS
▶ 154



V-921
ELGA DUE
▶ 154



V-1712
MORPHOS LIGHT
▶ 154



V-1771
AMLETO
▶ 155



V-1751
SOLE
▶ 155



V-1761
CASTO
▶ 155



V-1681
VOLA
▶ 155



V-1601
CUBUS
▶ 155



V-1781
DALÌ
▶ 155



V-1691
GO-GO
▶ 155



V-140
DAYTONA
▶ 155



V-101
L-FORM 90
▶ 155



V-1801
TECNO
▶ 156



V-910
▶ 156



V-110-INOX
U-FORM
▶ 156



V-141
CAPRI
▶ 156



V-111
MILANO
▶ 156



V-1391
VITREA COLOR
▶ 156



V-121
SABBIA
▶ 156



V-1791
WIND
▶ 156



MANIGLIONI AD INCOLLAGGIO PULLHANDLES WITH SELF-ADHESIVE STOSSGRIFFE SELBSTKLEBEND

SQUARE 10-INC
▶ 160



POR-0400 V
▶ 159



POR-0408 V
▶ 159



MANIGLIONI MINI PULLHANDLES MINI MINI STOSSGRIFFE

SQUARE 10-INC
∅ 10 x 15
▶ 158



SQUARE ALU
∅ 14
▶ 160



ROUND MINI
∅ 16
▶ 160



SQUARE MINI
∅ 15
▶ 160



**MANIGLIONI
PULLHANDLES
STOSSGRIFFE**

ROUND 02
Ø 20 / Ø 25 / Ø 30
▶ 161



SQUARE 41
∅ 19 / ∅ 25 / ∅ 40
▶ 161



SQUARE 40
∅ 25
▶ 161



ROUND 10
Ø 20 / Ø 25 / Ø 30
▶ 161



ROUND 01
Ø 20 / Ø 25 / Ø 30
▶ 161



ROUND 11
Ø 25
▶ 161



ROUND 03
Ø 25 / Ø 30
▶ 162



ROUND 08
Ø 32
▶ 162



ROUND 09
Ø 32
▶ 162



**MANIGLIONI CON SERRATURA DUOLOCK
PULLHANDLES WITH LOCK DUOLOCK
VERSPERBARE STOSSGRIFFE DUOLOCK**

DUOLOCK
L=1500 mm
▶ 163



DUOLOCK H
L=2200 mm
▶ 163



**MANIGLIONI ANTIPANICO
PANIC EXIT DEVICES
PANIK STOSSGRIFFE**

A-100
▶ 164



**NICCHIE PER SCORREVOLI
SLIDING HANDLES
GRIFFMUSCHELN**

- NICCHIE
 - SLIDING HANDLES
 - GRIFFMUSCHELN
- ▶ 168 - 173



**POMOLI
KNOBS
KNÖPFE**

- POMOLI
 - KNOBS
 - KNÖPFE
- ▶ 174 - 177

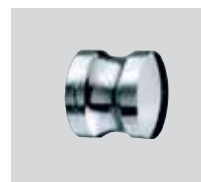

MANIGLIE

DOORHANDLES / TÜRGRIFFE



V-1711 MORPHOS

€► F.01

- Paio maniglie per serrature vetro (serratura e rosetta escluse)
 - Pair handles for glasslocks (lock and rosette not included)
 - Paar Türgriffe für Glastürschlösser (Schloss und Rosette nicht enthalten)
- CR/CS - NL/NS

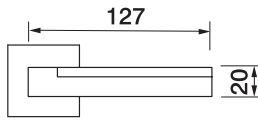

V-1651 DUNE

€► F.03

- Paio maniglie per serrature vetro (serratura e rosetta escluse)
 - Pair handles for glasslocks (lock and rosette not included)
 - Paar Türgriffe für Glastürschlösser (Schloss und Rosette nicht enthalten)
- CS - NS - CR - OL

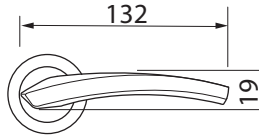

V-1611 BLADE

€► F.05

- Paio maniglie per serrature vetro (serratura e rosetta escluse)
 - Pair handles for glasslocks (lock and rosette not included)
 - Paar Türgriffe für Glastürschlösser (Schloss und Rosette nicht enthalten)
- CS - NS - CR - OL

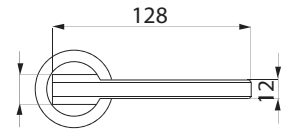

V-1731 ELEKTRA

€► F.07

- Paio maniglie per serrature vetro (serratura e rosetta escluse)
 - Pair handles for glasslocks (lock and rosette not included)
 - Paar Türgriffe für Glastürschlösser (Schloss und Rosette nicht enthalten)
- AN - CS - NS - CR - CP - OL

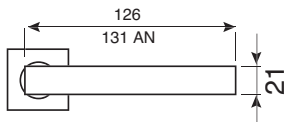

V-1721 PRESO

€► F.02

- Paio maniglie per serrature vetro (serratura e rosetta escluse)
 - Pair handles for glasslocks (lock and rosette not included)
 - Paar Türgriffe für Glastürschlösser (Schloss und Rosette nicht enthalten)
- CS - NS - CR - OL

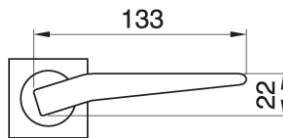

V-1762 RATIO

€► F.04

- Paio maniglie per serrature vetro (serratura e rosetta escluse)
 - Pair handles for glasslocks (lock and rosette not included)
 - Paar Türgriffe für Glastürschlösser (Schloss und Rosette nicht enthalten)
- CS - NS - CR

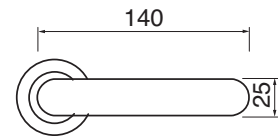

V-1671 LE MANS

€► F.06

- Paio maniglie per serrature vetro (serratura e rosetta escluse)
 - Pair handles for glasslocks (lock and rosette not included)
 - Paar Türgriffe für Glastürschlösser (Schloss und Rosette nicht enthalten)
- CS - NS - CR - OL

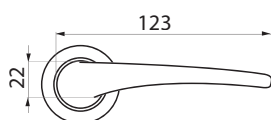

V-921 ELGA DUE

€► F.08

- Paio maniglie per serrature vetro (serratura esclusa)
 - Pair handles for Glasslocks (Lock not included)
 - Paar Türgriffe für Glastürschlösser (Schloss nicht enthalten)
- CS - NS - CP - CR - NO

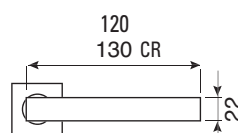

V-1712 MORPHOS LIGHT

€► F.10

- Paio maniglie per serrature vetro (serratura e rosetta escluse)
 - Pair handles for glasslocks (lock and rosette not included)
 - Paar Türgriffe für Glastürschlösser (Schloss und Rosette nicht enthalten)
- CS - NS - CR

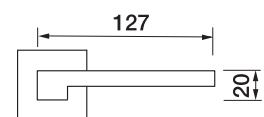



V-1771 AMLETO

€▶ F.27

- Paio maniglie per serrature vetro (serratura e rosetta escluse)
 - Pair handles for glasslocks (lock and rosette not included)
 - Paar Türgriffe für Glastürschlösser (Schloss und Rosette nicht enthalten)
- CS - NS - CR

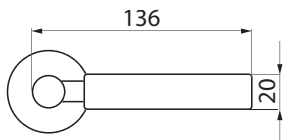

V-1751 SOLE

€▶ F.21

- Paio maniglie per serrature vetro (serratura e rosetta escluse)
 - Pair handles for glasslocks (lock and rosette not included)
 - Paar Türgriffe für Glastürschlösser (Schloss und Rosette nicht enthalten)
- CS - NS - CR - CP - OL

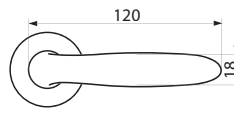

V-1761 CASTO

€▶ F.14

- Paio maniglie per serrature vetro (serratura e rosetta escluse)
 - Pair handles for glasslocks (lock and rosette not included)
 - Paar Türgriffe für Glastürschlösser (Schloss und Rosette nicht enthalten)
- CS - NS - CR - CP - OL

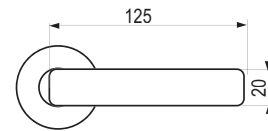

V-1681 VOLA

€▶ F.16

- Paio maniglie per serrature vetro (serratura e rosetta escluse)
 - Pair handles for glasslocks (lock and rosette not included)
 - Paar Türgriffe für Glastürschlösser (Schloss und Rosette nicht enthalten)
- CS - NS - CR - OL

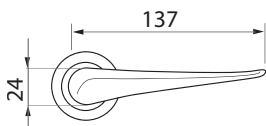

V-1601 CUBUS

€▶ F.11

- Paio maniglie per serrature vetro (serratura e rosetta escluse)
 - Pair handles for glasslocks (lock and rosette not included)
 - Paar Türgriffe für Glastürschlösser (Schloss und Rosette nicht enthalten)
- CS - NS - CR

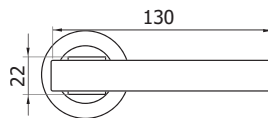

V-1781 DALI

€▶ F.13

- Paio maniglie per serrature vetro (serratura e rosetta escluse)
 - Pair handles for glasslocks (lock and rosette not included)
 - Paar Türgriffe für Glastürschlösser (Schloss und Rosette nicht enthalten)
- CS - NS - CR

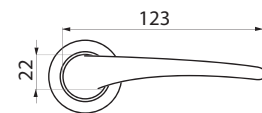

V-1691 GO-GO

€▶ F.15

- Paio maniglie per serrature vetro (serratura e rosetta escluse)
 - Pair handles for glasslocks (lock and rosette not included)
 - Paar Türgriffe für Glastürschlösser (Schloss und Rosette nicht enthalten)
- CS - NS - CR - OL

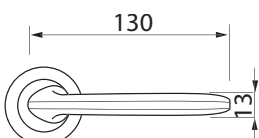

V-140 DAYTONA

€▶ F.17

- Paio maniglie per serrature vetro (serratura e rosetta escluse)
 - Pair handles for glasslocks (lock and rosette not included)
 - Paar Türgriffe für Glastürschlösser (Schloss und Rosette nicht enthalten)
- CS - NS - CR - CP - OL

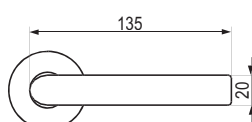

V-101 L-FORM 90

€▶ F.09

- Paio maniglie per serrature vetro (serratura e rosetta escluse)
 - Pair handles for glasslocks (lock and rosette not included)
 - Paar Türgriffe für Glastürschlösser (Schloss und Rosette nicht enthalten)
- IX - AN

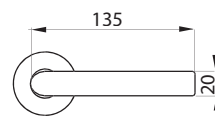



V-110-INOX U-FORM

€▶ F.19

- Paio maniglie per serrature vetro (serratura e rosetta escluse)
 - Pair handles for glasslocks (lock and rosette not included)
 - Paar Türgriffe für Glastürschlösser (Schloss und Rosette nicht enthalten)
- IX - AN

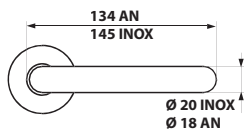

V-910

€▶ F.12

- Paio maniglie per serrature vetro (serratura e rosetta escluse)
 - Pair handles for glasslocks (lock and rosette not included)
 - Paar Türgriffe für Glastürschlösser (Schloss und Rosette nicht enthalten)
- CS - NS - CR - CP - CR - NO

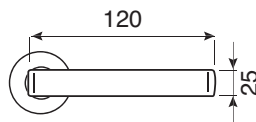

V-141 CAPRI

€▶ F.17

- Paio maniglie per serrature vetro (serratura e rosetta escluse)
 - Pair handles for glasslocks (lock and rosette not included)
 - Paar Türgriffe für Glastürschlösser (Schloss und Rosette nicht enthalten)
- CS - NS - CR - OL

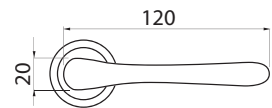

V-111 MILANO

€▶ F.18

- Paio maniglie per serrature vetro (serratura e rosetta escluse)
 - Pair handles for glasslocks (lock and rosette not included)
 - Paar Türgriffe für Glastürschlösser (Schloss und Rosette nicht enthalten)
- CS - NS - CR - CP - OL

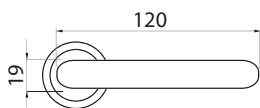

V-1391 VITREA COLOR

€▶ F.28

- Paio maniglie per serrature vetro (serratura e rosetta escluse)
 - Pair handles for glasslocks (lock and rosette not included)
 - Paar Türgriffe für Glastürschlösser (Schloss und Rosette nicht enthalten)
- CS - NS - CR - OL

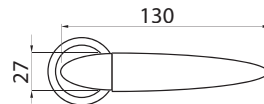

V-121 SABBIA

€▶ F.25

- Paio maniglie per serrature vetro (serratura e rosetta escluse)
 - Pair handles for glasslocks (lock and rosette not included)
 - Paar Türgriffe für Glastürschlösser (Schloss und Rosette nicht enthalten)
- AN - CS - NS - CR - CP - OL

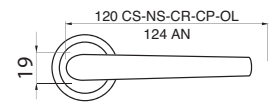

V-1801 TECNO

€▶ F.20

- Paio maniglie per serrature vetro (serratura e rosetta escluse)
 - Pair handles for glasslocks (lock and rosette not included)
 - Paar Türgriffe für Glastürschlösser (Schloss und Rosette nicht enthalten)
- CR - NS - CS

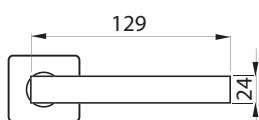

V-1791 WIND

€▶ F.26

- Paio maniglie per serrature vetro (serratura e rosetta escluse)
 - Pair handles for glasslocks (lock and rosette not included)
 - Paar Türgriffe für Glastürschlösser (Schloss und Rosette nicht enthalten)
- CS - NS - CR

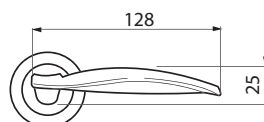



ROSETTE ROSETTE / ROSETTE

EXTRA: PER MANIGLIE CON ROSETTE PER PORTE IN LEGNO
 EXTRA: FOR DOORHANDLES WITH ROSETTE FOR WOODEN DOORS / EXTRA: FÜR TÜRGRIFFE MIT ROSETTE FÜR HOLZTÜREN



ROS-T-BB
 CP - CR - CS - NS - OL

€ F.29

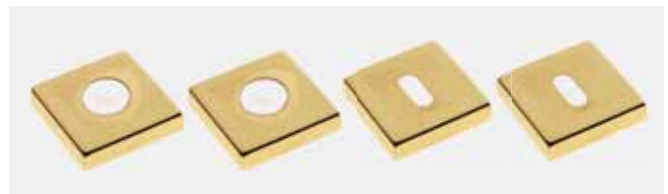
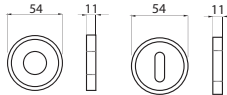

ROS-Q-BB
 CP - CR - CS - NS - OL

€ F.30

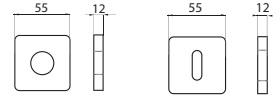

ROS-T-PZ
 CP - CR - CS - NS - OL

€ F.31

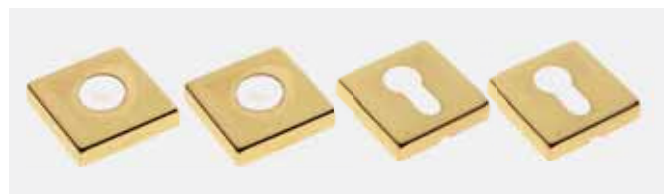
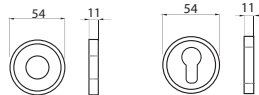

ROS-Q-PZ
 CP - CR - CS - NS - OL

€ F.32

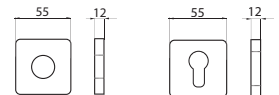

ROS-T-WC
 CP - CR - CS - NS - OL

€ F.33

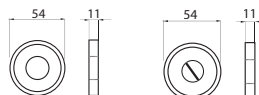

ROS-Q-WC
 CP - CR - CS - NS - OL

€ F.34

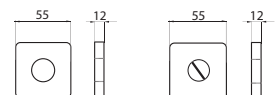

MANIGLIONI AD INCOLLAGGIO PULLHANDLES WITH SELF-ADHESIVE / STOSSGRIFFE SELBSTKLEBEND

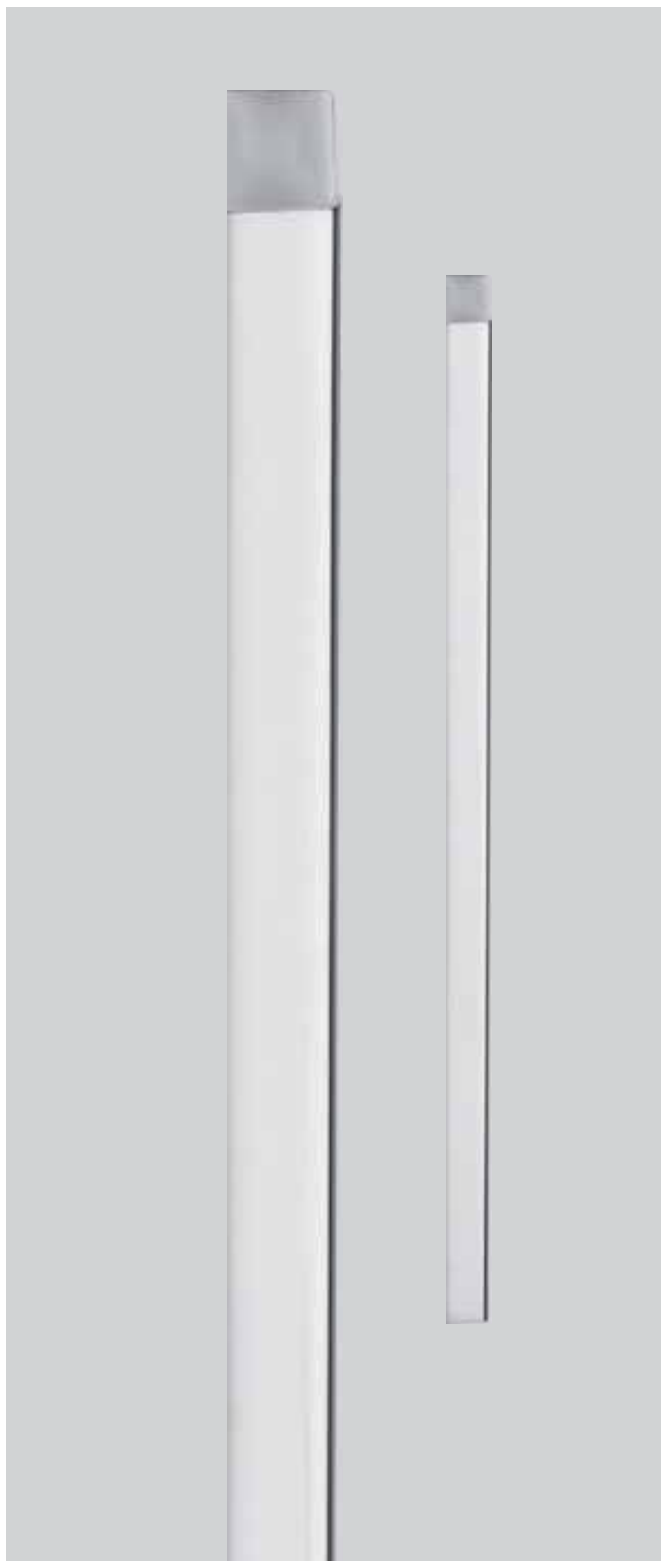

SQUARE 10-INC

€ F.35

∅	Code	TL	Materiale Material Material	Unit.	Finitura Finishes Oberfläche
10 x 15	10.41.81/300	300	Alluminio Aluminium Aluminium	Singolo Piece Stück	AN
10 x 15	10.41.51/300	300	Ottone Brass Messing	Singolo Piece Stück	CR
10 x 15	10.41.61/300	300	Alluminio Aluminium Aluminium	Singolo Piece Stück	CR EFFECT
10 x 15	10.41.71/300	300	Alluminio Aluminium Aluminium	Singolo Piece Stück	NO
10 x 15	10.41.81/500	500	Alluminio Aluminium Aluminium	Singolo Piece Stück	AN
10 x 15	10.41.51/500	500	Ottone Brass Messing	Singolo Piece Stück	CR
10 x 15	10.41.61/500	500	Alluminio Aluminium Aluminium	Singolo Piece Stück	CR EFFECT
10 x 15	10.41.71/500	500	Alluminio Aluminium Aluminium	Singolo Piece Stück	NO

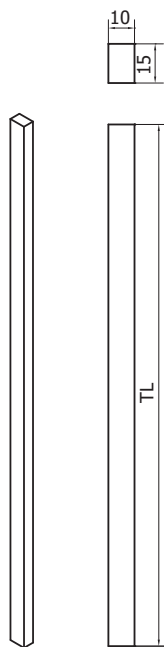

MANIGLIE E
MANIGLIONI



- Pulire con solvente
 - Clean with solvent
 - Mit Lösungsmittel reinigen



- Asciugare con un panno
 - Dry with a cloth
 - Mit einem Tuch trocknen



- Staccare la pellicola protettiva e applicare
 - Remove the protective film and apply
 - Die Schutzfolie abziehen und anbringen

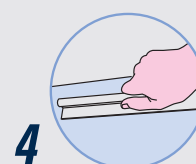

- Premere con forza
 - Press firmly
 - Fest drücken

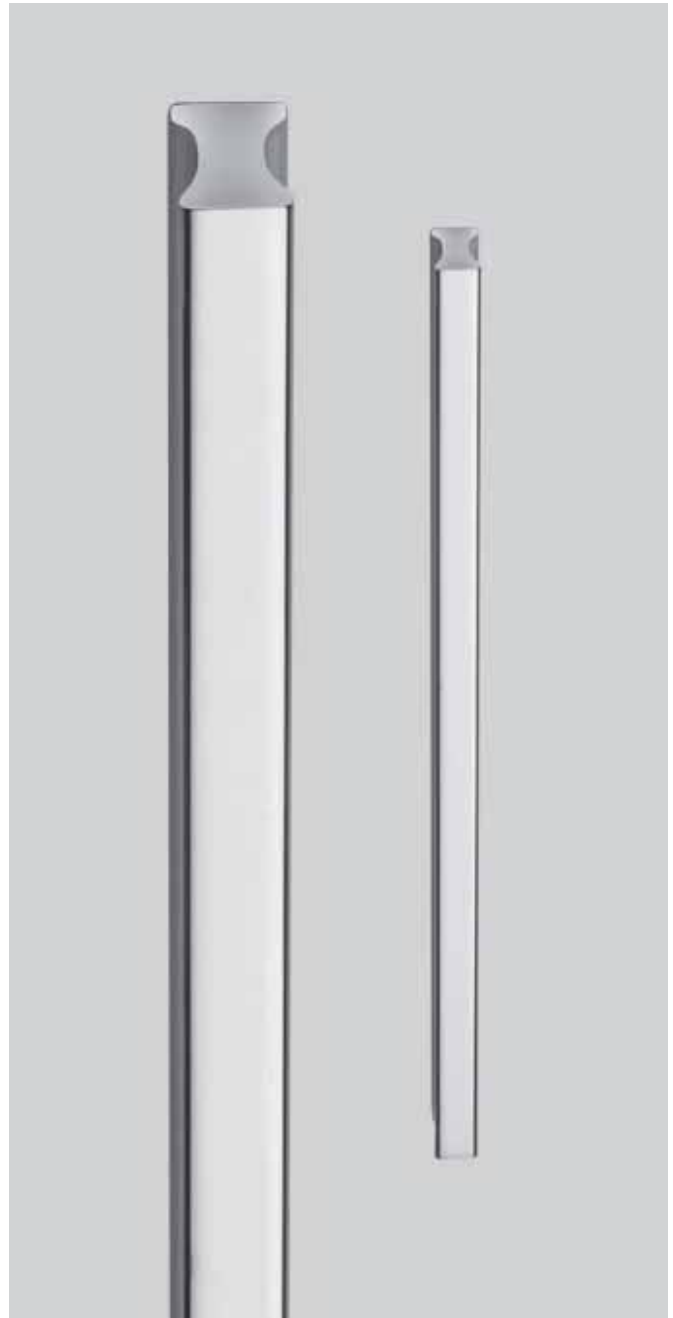
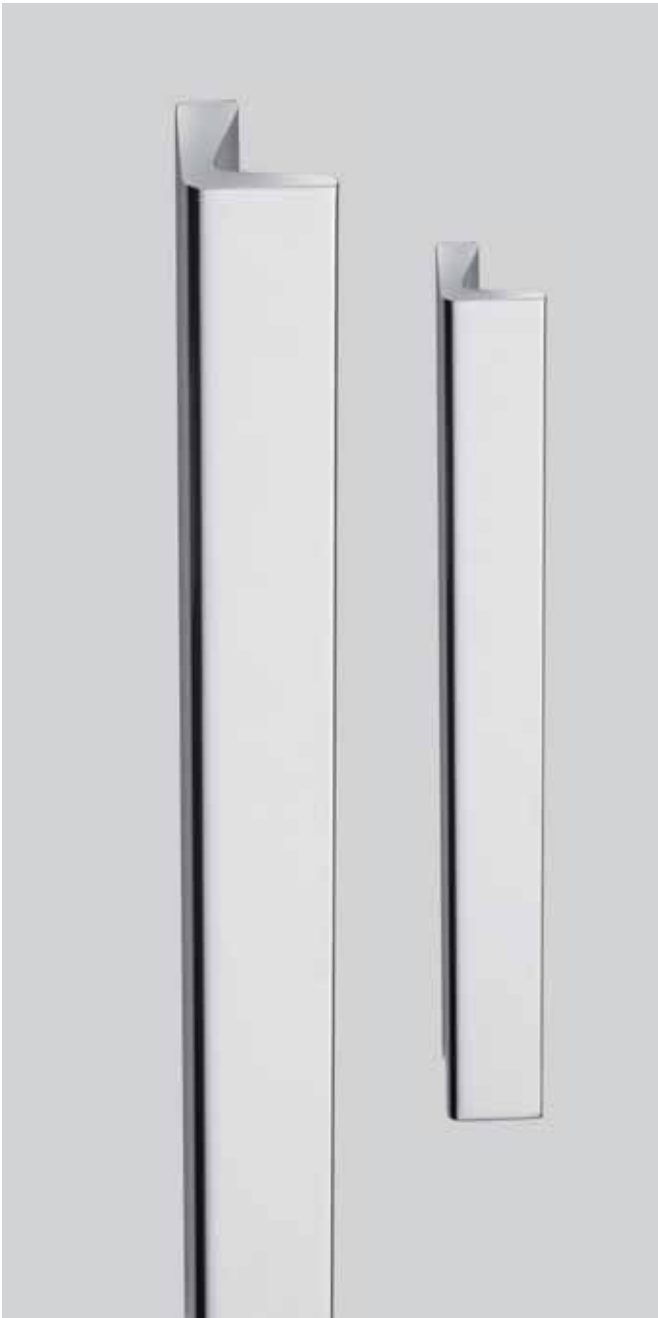
POR-0400 V

F.36

- Maniglione alluminio senza fori nel vetro ad incollaggio con biadesivo 3M
- Pullhandle in aluminium without holes in glass fixing with 3M self-adhesive
- Stossgriffe aus Aluminium ohne Glasbearbeitung selbstklebend

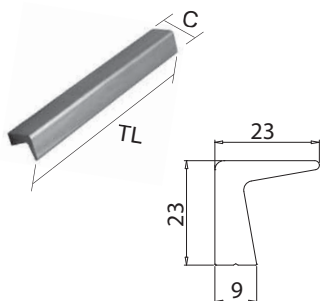

TL	C	Unit.	Finitura Finishes Oberfläche
240	23	Singolo Piece Stück	AN
			CR
			NS
390	23	Singolo Piece Stück	AN
			CR
			NS
540	23	Singolo Piece Stück	AN
			CR
			NS

POR-0408 V

F.37

- Maniglione alluminio senza fori nel vetro ad incollaggio con biadesivo 3M
- Pullhandle in aluminium without holes in glass fixing with 3M self-adhesive
- Stossgriffe aus Aluminium ohne Glasbearbeitung selbstklebend

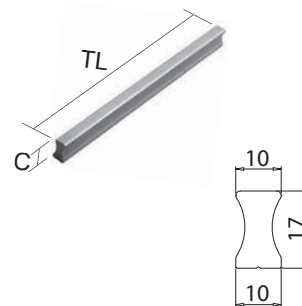

TL	C	Unit.	Finitura Finishes Oberfläche
260	17	Singolo Piece Stück	AN
			CR
			NS
410	17	Singolo Piece Stück	AN
			CR
			NS
560	17	Singolo Piece Stück	AN
			CR
			NS

MANIGLIONI MINI Ø 16 - Ø 15 / MANIGLIONI PULLHANDLES / STOSSGRIFFE



ROUND MINI Ø 16

- Maniglione inox
- Pullhandle inox
- Stossgriff inox

IX - IL

TL	225	300	
	135	•	Ø 9
A	200	•	Ø 9

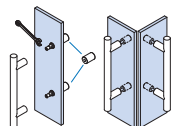
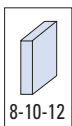
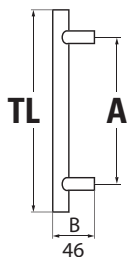

Option with Knob **B-177** page **175**

€ ▶ **F.114**



SQUARE MINI Ø 15

- Maniglione inox.
- Pullhandle inox.
- Stossgriff Inox.

IX - IL

TL	150	215	315	
	135	•	•	Ø 9
A	200	•	•	Ø 9
	300	•	•	Ø 9

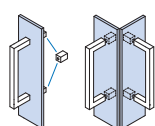
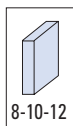

Option with Knob **B-178** page **175**

€ ▶ **F.115**



SQUARE Alu Ø 14

- Maniglione. Materiale: Alluminio
- Pullhandle. Material: Aluminium
- Stossgriff. Material: Aluminium

AN - CR

TL	174	206	334	
	160	•	•	Ø 8,5
A	192	•	•	Ø 8,5
	320	•	•	Ø 8,5

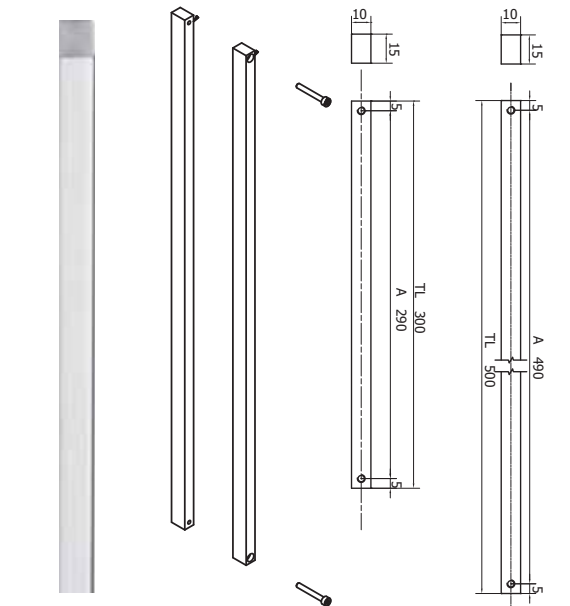
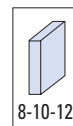

SQUARE 10

- Maniglione
- Pullhandle
- Stossgriff

AN - CR - NS

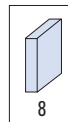

Ø	Code	A	TL		Materiale Material Material	Unit.	Finitura Finishes Oberfläche
10 x 15	10.41.53/290.300	290	300	8	Ottone Brass Messing	Paio Pair Paar	CR
10 x 15	10.41.63/290.300	290	300	8	Alluminio Aluminium Aluminium	Paio Pair Paar	CR EFFECT
10 x 15	10.41.73/290.300	290	300	8	Alluminio Aluminium Aluminium	Paio Pair Paar	NO
10 x 15	10.41.53/490.500	490	500	8	Ottone Brass Messing	Paio Pair Paar	CR
10 x 15	10.41.63/490.500	490	500	8	Alluminio Aluminium Aluminium	Paio Pair Paar	CR EFFECT

MANIGLIE
MANIGLIONI



Foro vetro
Glass hole
Glasbohrung

IX
Acciaio inox satinato
Satin stainless steel
Edelstahl matt

CR
Cromo lucido
Polished chrome
Chrom glänzend

AN
Alluminio anodizzato
Aluminium anodized
Aluminium Silberfarbig

IL
Acciaio inox lucido
Polished stainless steel
Edelstahl poliert

NS
Nickel satinato
Satin nickel
Ähnlich Edelstahl matt

MANIGLIONI Ø 20 / 25 / 30 - Ø 19 / 25 / 40

PULLHANDLES / STOSSGRIFFE

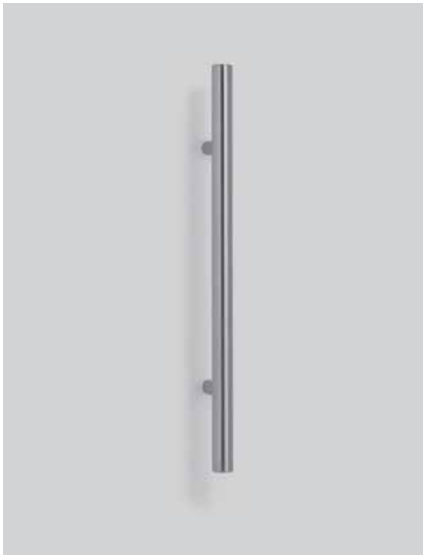
ROUND 02

- Maniglione
- Pullhandle
- Stossgriff

IX

F.46

Ø	A	200	300	500	650	1000	1040	1370	
20		•	•	•			•		Ø10
25			•	•	•				Ø12
30				•		•		•	Ø12
40									

SQUARE 41

- Maniglione
- Pullhandle
- Stossgriff

IX

F.48

Ø	A	200	300	650	
19		•			Ø10
25			•		Ø12
30					
40			•		Ø12

SQUARE 40

- Maniglione
- Pullhandle
- Stossgriff

IX

F.49

Ø	A	300	
20			
25		•	Ø12
30			
40			

ROUND 10

- Maniglione
- Pullhandle
- Stossgriff

IX

F.47

Ø	A	300	650	1000	
20		•			Ø10
25		•	•		Ø12
30			•		Ø12
40					

ROUND 01

- Maniglione
- Pullhandle
- Stossgriff

IX

F.50

Ø	A	200	300	350	400	650	
20		•	•				Ø10
25			•	•	•		Ø12
30			•		•		Ø12
40							

ROUND 11

- Maniglione
- Pullhandle
- Stossgriff

IX

F.51

Ø	A	350	620	
20				
25		•	•	Ø12
30				
40				





ROUND 03

- Maniglione
- Pullhandle
- Stossgriff

IX

€▶ F.53

Ø	A		
	200		
	275		
	350		
	650		
20			
25		•	Ø12
30		• •	Ø12
40			



ROUND 08

- Maniglione
- Pullhandle
- Stossgriff

IX

€▶ F.52

Ø	A		
	400		
20			
25			
32		•	Ø12
40			



ROUND 09

- Maniglione
- Pullhandle
- Stossgriff

IX

€▶ F.54

Ø	A		
	300		
20			
25			
32		•	Ø12
40			



SET FISSAGGIO SCIOLTI
 FIXATION SYSTEMS / BEFESTIGUNGSSYSTEME



FIX-01-20

- Set fissaggio singolo per maniglioni Ø 20 e filetto M 6
- Set installation for single pullhandle Ø 20 and thread M 6
- Befestigungsset für 1 Stück Stossgriff Ø 20 und Gewinde M 6

€▶ F.55

FIX-01-25

- Set fissaggio singolo per maniglioni Ø 25 e filetto M 6
- Set installation for single pullhandle Ø 25 and thread M 6
- Befestigungsset für 1 Stück Stossgriff Ø 25 und Gewinde M 6

€▶ F.56

FIX-01-30

- Set fissaggio singolo per maniglioni Ø 30 e filetto M 8
- Set installation for single pullhandle Ø 30 and thread M 8
- Befestigungsset für 1 Stück Stossgriff Ø 30 und Gewinde M 8

€▶ F.57



FIX-03-20

- Set fissaggio paio per maniglioni Ø 20 e filetto M 6
- Set installation for pair pullhandles Ø 20 and thread M 6
- Befestigungsset für 1 Paar Stossgriffe Ø 20 und Gewinde M 6

€▶ F.58

FIX-03-25

- Set fissaggio paio per maniglioni Ø 25 e filetto M 6
- Set installation for pair pullhandles Ø 25 and thread M 6
- Befestigungsset für 1 Paar Stossgriffe Ø 25 und Gewinde M 6

€▶ F.59

FIX-03-30

- Set fissaggio paio per maniglioni Ø 30 e filetto M 8
- Set installation for pair pullhandles Ø 30 and thread M 8
- Befestigungsset für 1 Paar Stossgriffe Ø 30 und Gewinde M 8

€▶ F.60



FIX-09-20

- Set fissaggio singolo per maniglioni porta legno Ø 20
- Set installation for single pullhandle Ø 20 - for wooden door
- Befestigungsset für 1 Stück Stossgriff Ø 20 für Holztür

€▶ F.61

FIX-09-25

- Set fissaggio singolo per maniglioni porta legno Ø 25
- Set installation for single pullhandle Ø 25 - for wooden door
- Befestigungsset für 1 Stück Stossgriff Ø 25 für Holztür

€▶ F.62

FIX-09-30

- Set fissaggio singolo per maniglioni porta legno Ø 30
- Set installation for single pullhandle Ø 30 - for wooden door
- Befestigungsset für 1 Stück Stossgriff Ø 30 für Holztür

€▶ F.63

MANIGLIONI CON SERRATURA DUOLOCK

PULLHANDLES WITH LOCK DUOLOCK / VERSPERBARE STOSSGRIFFE DUOLOCK

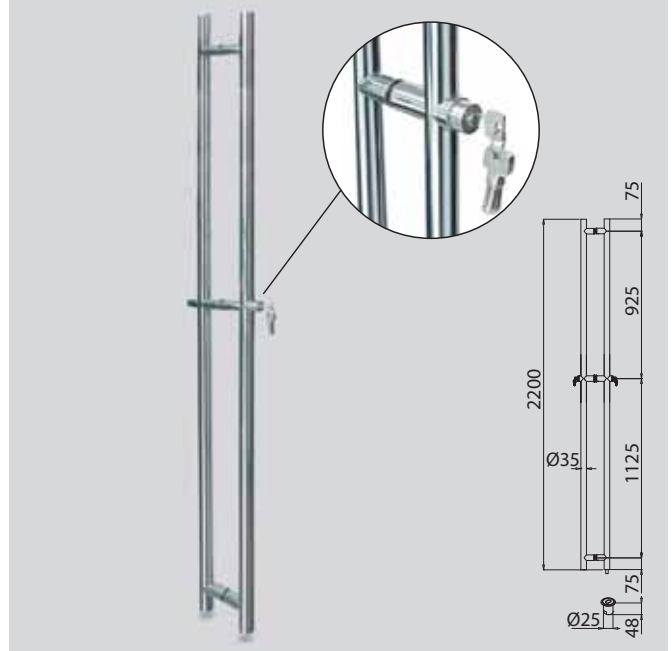
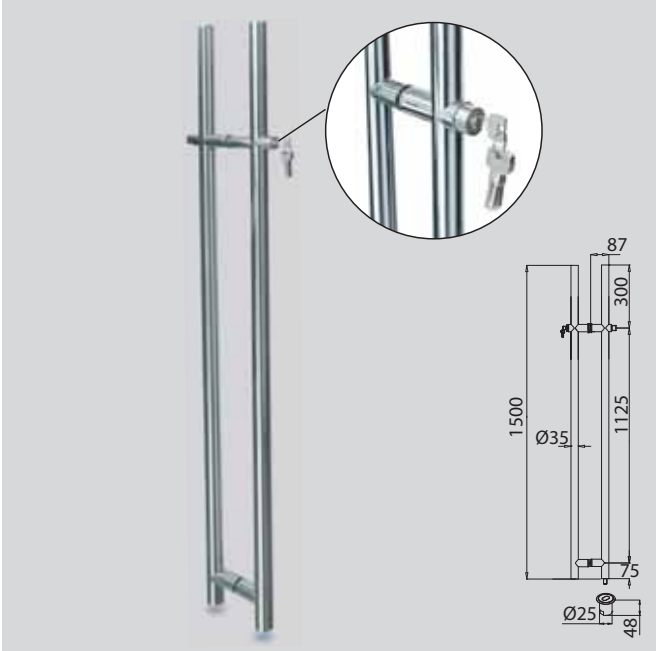

35.DL.13/1125.1500 € F.65
 • Duolock con serratura incorporata chiave/ pomolo
 • Duolock with lock key/knob
 • Duolock mit Schloss Schlüssel/Dreh-knopf

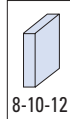

35.HD.13/1125.2200 € F.68
 • Duolock con serratura incorporata chiave/pomolo
 • Duolock with lock key/knob
 • Duolock mit Schloss Schlüssel/Dreh-knopf

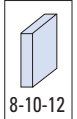

35.DLC.13/1125.1500 € F.65
 • Duolock con serratura incorporata chiave/chiave
 • Duolock with lock key/key
 • lock mit Schloss Schlüssel-Schlüssel
 IX

35.HDC.13/1125.2200 € F.68
 • Duolock con serratura incorporata chiave/chiave
 • Duolock with lock key/key
 • Duolock mit Schloss Schlüssel-Schlüssel
 IX

DL.LEGNO SET € F.66
 • Set attacchi per montaggio maniglioni Duolock su porte legno spessore 40-50 mm
 • Mounting set for installation on wooden door thickness 40-50 mm for pullhandles Duolock
 • Set für Duolock Stossgriffe Montage an Holztür 40-50 mm



DL-01 € F.69
 • Incontro superiore ad un punto fissaggio per maniglione Duolock-H.
 • Striker for pullhandle Duolock-H one point fixing.
 • Gegenkasten für Stossgriffe Duolock-H ein Befestigungspunkt.

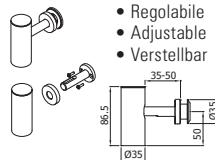

DL-02 € F.70
 • Incontro superiore a 2 punti per fissaggio maniglione
 • Two point fixing striker for pull handle Duolock-H
 • Duolock-H Gegenkasten für stossgriffe Duolock-H zwei Befestigungspunkten

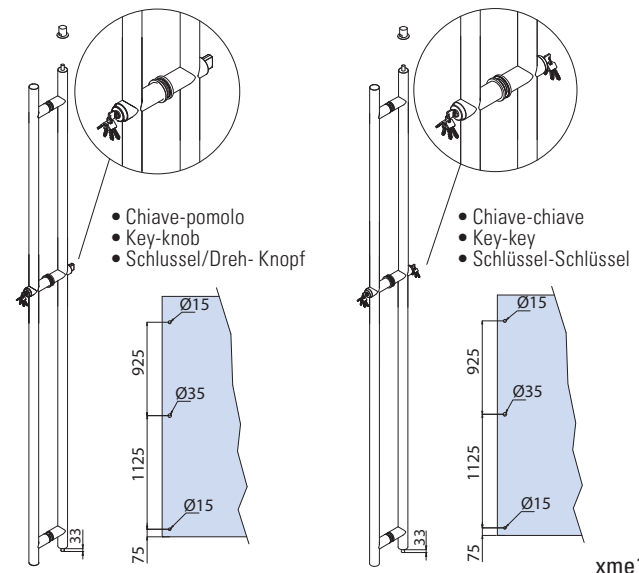
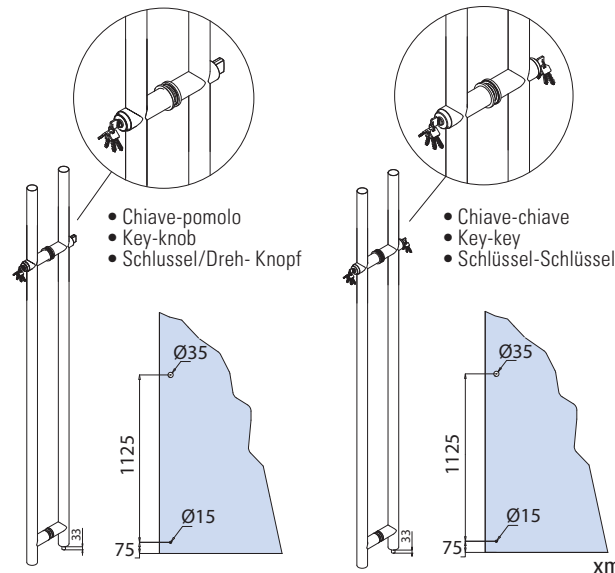
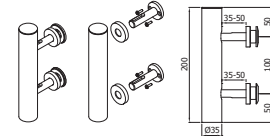

MANIGLIONI ANTIPANICO PANIC EXIT DEVICES / PANIK STOSSGRIFFE

A-100

€ ▶ F.81

- Sistema modulare 1 - 2 - 3 punti di chiusura, reversibile, facilità di montaggio. Corpo interno in acciaio zincato, coperture e leve in lega speciale, scrocco in acciaio inox, barra maniglione in acciaio inox. Scrocco comandato dalla barra orizzontale o dalla maniglia esterna
- Modular 1 - 2 - 3 locking points, reversible, simply assembly. Zinc plated steel cases - Covers and levers in special alloy - Stainless steel latch bolt - Stainless steel springs. Horizontal bar or outside accessories driven latch bolt.
- Modularer Aufbau erweiterbar von 1 auf 2 und 3 Punkt Verriegelung. Links und Rechts einsetzbar einfache Montage. Verzinkt Stahlkästen - Abdeckungen und Hebel in Zinklegierung - Falle aus Edelstahl - Federn aus Edelstahl. Stossgriff oder äußere Drücker treiben die Falle an.

NS - RAL7040 GREY

COMPONENTI / COMPONENTS / EINZELTEILE ▶ 167



- Il maniglione antipanico è certificato secondo la norma EN 1125:1997+A1:2001
- Panic exit device is certified in accordance with EN 1125:1997+A1:2001
- Panik-Verschluss-System ist entsprechend der Norm EN 1125:1997+A1:2001 zertifiziert



SET MANIGLIONI ANTIPANICO

SET PANIC EXIT DEVICES / SET PANIK STOSSRIGFFE

Anti-Set 1

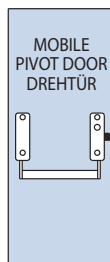

A-100 / A-101 / A-102

Anti-Set 2

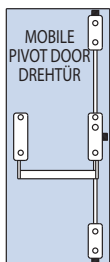

A-100 / A-101 / A-102
A-104 / A-106

Anti-Set 3

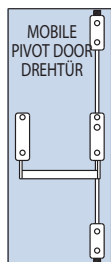

A-100 / A-101 / A-102
A-104 / A-106

Anti-Set 4

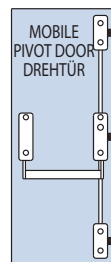

A-100 / A-101 / A-102
A-104 / A-106

Anti-Set 5

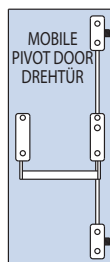

A-100 / A-101 / A-102
A-104 / A-106

Anti-Set 6



A-100 / A-101 / A-102

Anti-Set 7



A-100 / A-101 / A-102
A-104 / A-106 / A-107

Anti-Set 8

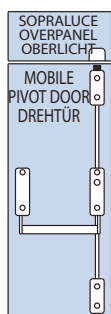

A-100 / A-101 / A-102
A-104 / A-106 / A-107

Anti-Set 9

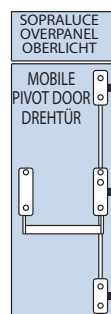

A-100 / A-101 / A-102
A-104 / A-106 / A-107

Anti-Set 10

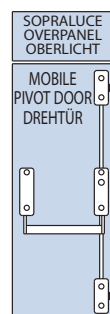

A-100 / A-101 / A-102
A-104 / A-106 / A-107

Anti-Set 11

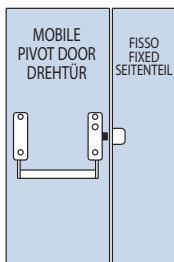

A-100 / A-101 / A-102
A-107

Anti-Set 12

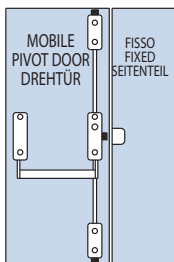

A-100 / A-101 / A-102
A-104 / A-106 / A-107

Anti-Set 13

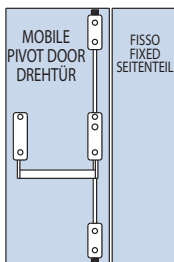

A-100 / A-101 / A-102
A-104 / A-106

Anti-Set 14

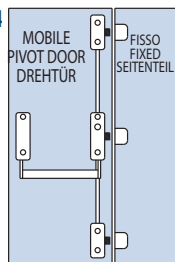

A-100 / A-101 / A-102
A-105 / A-106 / 3 x A-107

Anti-Set 15

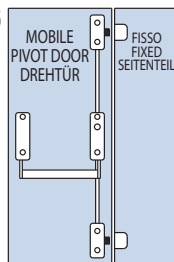

A-100 / A-101 / A-102
A-105 / A-106 / 2 x A-107

Anti-Set 16

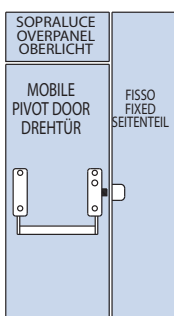

A-100 / A-101 / A-102
A-107

Anti-Set 17

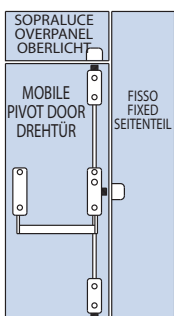

A-100 / A-101 / A-102
A-104 / A-106 / 2 x A-107

Anti-Set 18

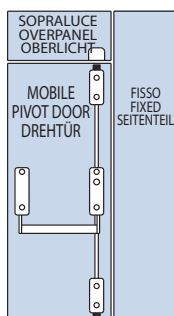

A-100 / A-101 / A-102
A-104 / A-106 / A-107

Anti-Set 19

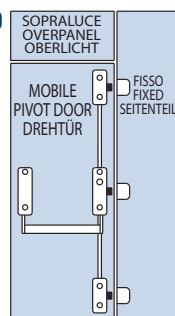

A-100 / A-101 / A-102
A-105 / A-106 / 3 x A-107

Anti-Set 20

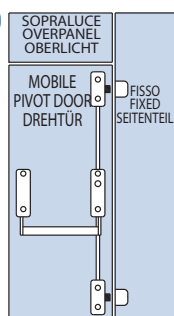

A-100 / A-101 / A-102
A-105 / A-106 / 2 x A-107

Anti-Set 21

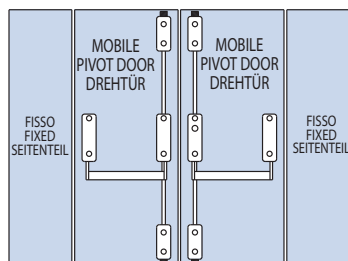

2 x A-100 / A-101 / A-102
A-103 / 2 x A-104 / 2 x A-106

Anti-Set 22

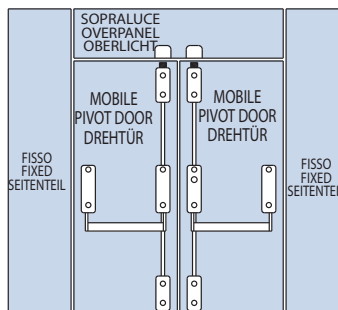

2 x A-100 / A-101 / A-102 A-103
2 x A-104 / 2 x A-106 2 x A-107

NS - RAL7040 GREY

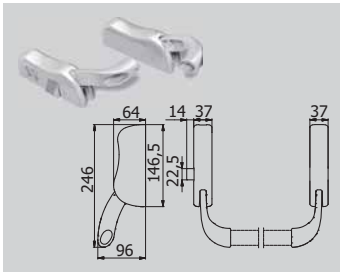

- A-100** €▶ F.71
- Maniglione antipanico triplice chiusura (modulare) reversibile, con barra orizzontale L = 1130 mm
 - Panic exit device three locking points (modular) reversible, with horizontal bar L = 1130 mm
 - Panik Stosgriff modulares System von 1 bis 3 Punkt-Verriegelung, Links/Rechts einsetzbar, mit Horizontaler Stange L = 1130 mm
- NS - RAL7040 GREY

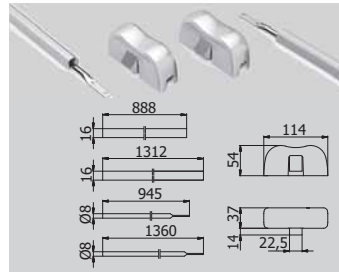

- A-105** €▶ F.76
- Kit deviatori laterali con copriaste
 - Kit side latch bolt with cover rod
 - Kit Seitliche Verriegelung mit Stangen Abdeckung
- NS - RAL7040 GREY

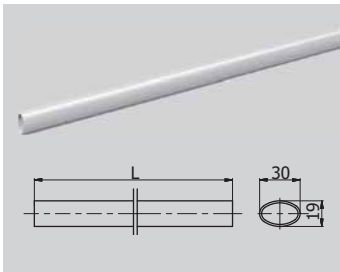

- A-108** €▶ F.78.1
- Optional barra orizzontale L = 1480 mm
 - Optional horizontal bar L = 1480 mm
 - Optional horizontale Stange L = 1480 mm
- IX - RAL7040 GREY

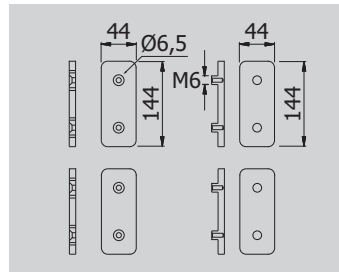

- A-106** €▶ F.77
- Kit fissaggio a vetro set deviatori A-104 o A-105
 - Kit for glass installation set latch bolts A-104 or A-105
 - Kit für Glasbefestigung A-104 oder A-105
- IX

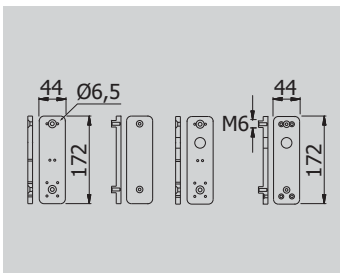

- A-101** €▶ F.72
- Kit per fissaggio a vetro maniglione antipanico A-100 maniglia esterna
 - Kit for glass installation panic exit device A-100 with outside handle
 - Kit für Glasbefestigung Panik Stosgriff A-100 mit Drückeraußen IX

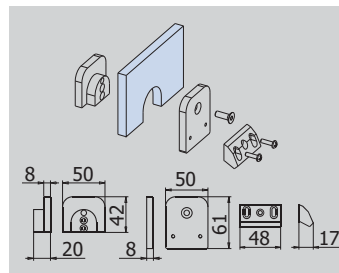

- A-107** €▶ F.78
- Set contropiastra per montaggio a vetro su sopralucente o laterale
 - Set for striker glass installation on overpanel or side pane
 - Set für Schließblech Glasbefestigung am Oberlicht oder Seitenteil
- IX

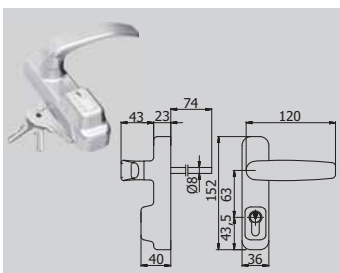

- A-102** €▶ F.73
- Placca esterna con maniglia e cilindro
 - Outside plate with handle and cylinder
 - Äußeres Schild mit Drücker und Zylinder
- NS - RAL7040 GREY

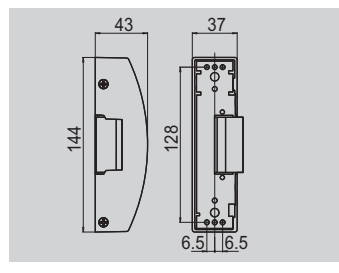

- A-109** €▶ F.79
- Incontro elettrico AC/DC 12 Volts
 - Electric strike plate AC/DC 12 Volts
 - Elektrisches Schließblech AC/DC 12 Volt
- NO - Nero / black / Schwarz

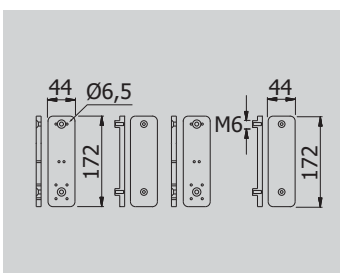

- A-103** €▶ F.74
- Kit per fissaggio a vetro maniglione antipanico A-100 senza maniglia esterna
 - Kit for glass installation panic exit device A-100 without outside handle
 - Kit für Glasbefestigung Panik Stosgriff A-100 ohne Drückeraußen IX

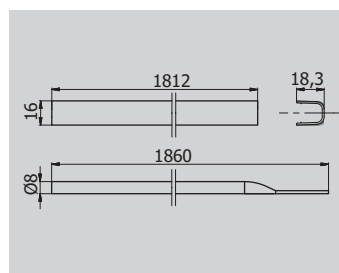

- A-110** €▶ F.80
- Kit di prolunga per deviatori per porte max H = 3000 mm
 - Prolongation kit for deviators for doors max H = 3000 mm
 - Kit Verlängerungen für Verriegelungen, Tür Höhe max H = 3000 mm
- NS - RAL7040 GREY

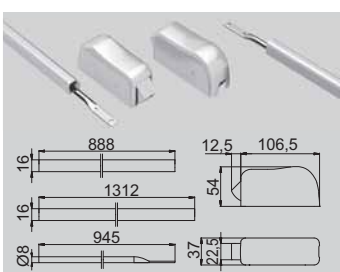

- A-104** €▶ F.75
- Kit deviatori alto/basso con copriaste
 - Kit top and bottom latch bolt with cover rod
 - Kit oben/unten Verriegelung mit Stangen Abdeckung
- NS - RAL7040 GREY

NICCHIE PER SCORREVOLI SLIDING HANDLES / GRIFFMUSCHEL



V-506

- Paio nicchie scorrevoli Minima senza viti in vista
- Pair sliding door-handles Minima without visible screws
- Paar Griffmuscheln Minima ohne sichtbare Schrauben

CS - NS - CR - CP - GR

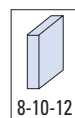
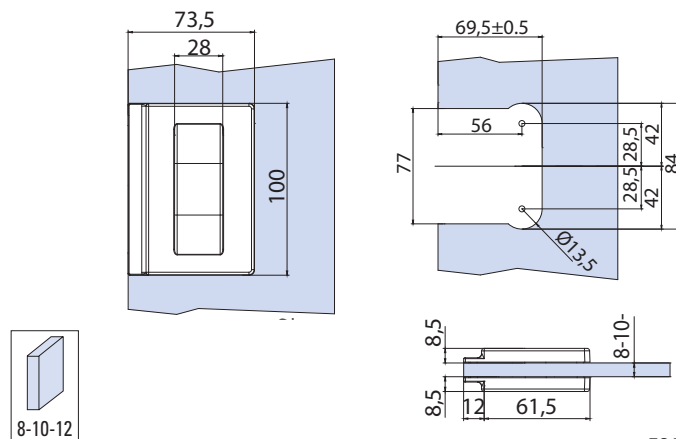

€ F.82

xme521



V-406

- Paio nicchie scorrevoli con tirante.
- Pair sliding handles with pull-lever.
- Paar Griffmuscheln mit stirnseitigem Griff.

NS - CR - CP

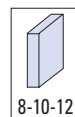
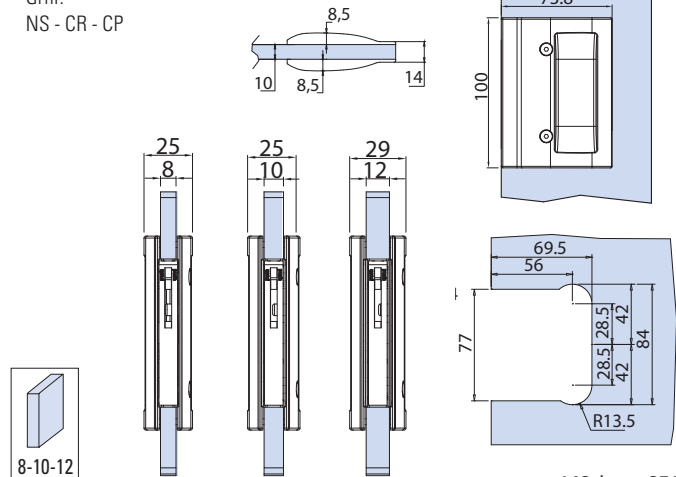

€ F.88

xme143 / xme351



FROM 07/20

V-406-R

- Paio nicchie per porte scorrevoli a scomparsa con tirante. Frontale ribassato spessore 15 mm. Spessore totale nicchia 20 mm
- Pair sliding handles with flush pull lever for pocket doors. Frontal thickness 15 mm. Handle total thickness 20 mm
- Paar Griffmuscheln mit stirnseitigem Griff für Kastenrahmensysteme. Stärke Vorderseite 15 mm, Gesamtstärke 20 mm

AN - NS - GR

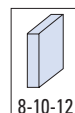
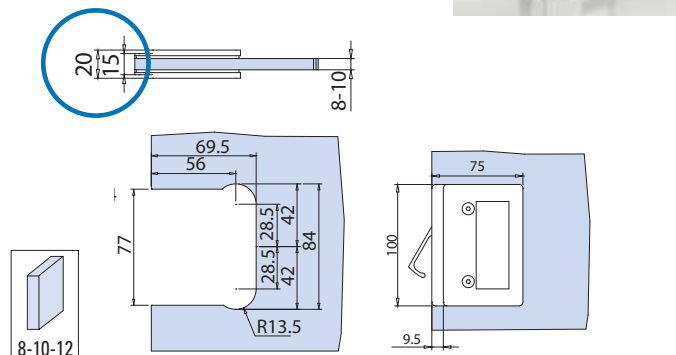

€ F.87

xfb-114



V-511

- Paio nicchie scorrevole senza viti a vista
 - Pair sliding door handles with invisible fixing screws
 - Paar Griffmuscheln mit nicht sichtbaren Schrauben
- CS - NS - CR - CP - NO

€ F.84

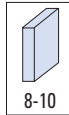
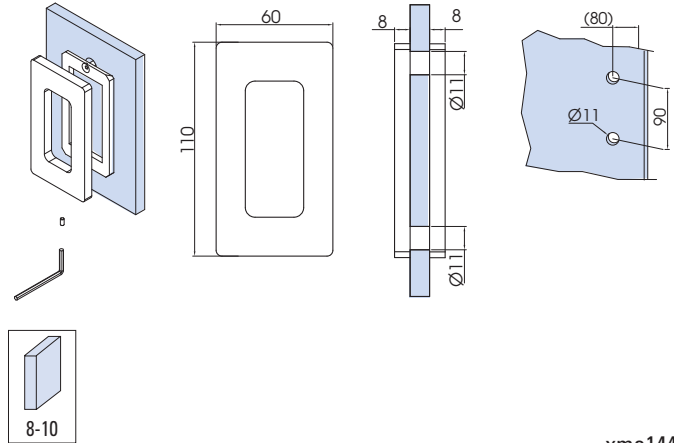

xme144



V-534-INC

- Nicchia scorrevole ad incollaggio biadesivo
 - Sliding door-handle with self adhesive fixing
 - Griffmuschel Gröss selbstklebend
- CS - NS - CR - OL

€ F.92

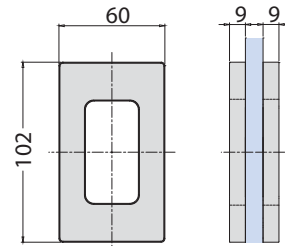

V-511-INC

- Nicchia scorrevole ad incollaggio biadesivo
 - Sliding door-handle with self adhesive fixing
 - Griffmuschel Gröss selbstklebend
- OL

€ F.85

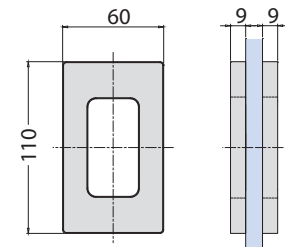

xfb-nicchie ad incollaggio



V-510

- Paio nicchie per scorrevole senza viti a vista
 - Pair sliding door handles with invisible fixing screws
 - Paar Griffmuscheln mit nicht sichtbaren Schrauben
- CS - NS - CR - CP

€ F.83

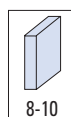
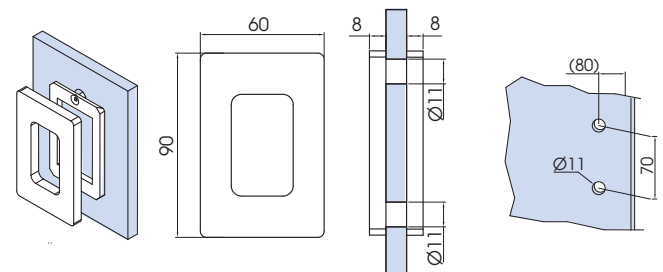

xme144



V-522

- Paio nicchie quadre per scorrevole
- Pair sliding door-handles square
- Paar eckige Griffmuscheln

AN - NS - CR

€ F.86

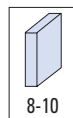
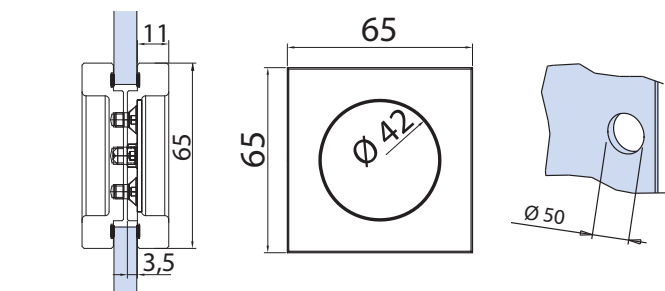

xme015



V-522-INC

- Nicchia quadra per scorrevole ad incollaggio biadesivo
- Sliding door-handle square, with self adhesive fixing
- Eckige griffmuschel, selbstklebend

AN - NS

€ F.86

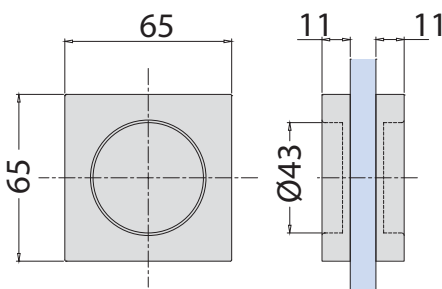

1 pcs

xfb-nicchie ad incollaggio



V-533-INC

- Nicchia quadra per scorrevole ad incollaggio biadesivo
- Sliding door-handle square, with self adhesive fixing
- Eckige griffmuschel, selbstklebend

AN - NS

€ F.91

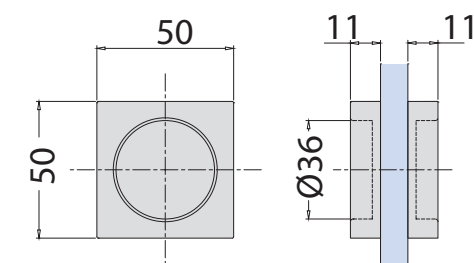

1 pcs

xfb-nicchie ad incollaggio



V-512

€▶ F.93

- Paio nicchie per scorrevole tonde, Ø 65.
 - Pair sliding door-handles, Ø 65
 - Paar Griffmuscheln, Ø 65
- AN - CS - NS - CR - OL - NO

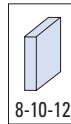
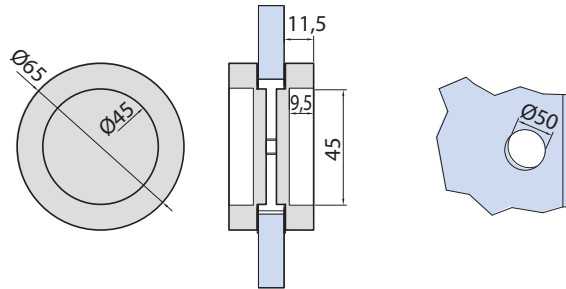

xme050



V-524-08 (per vetro / for glass / für Glas 8 mm)

€▶ F.95

V-524-10 (per vetro / for glass / für Glas 10 mm)

- Paio nicchie per scorrevole tonde, Ø 60
 - Pair sliding door-handles, Ø 60
 - Paar Griffmuscheln, Ø 60
- AN - NS - CR

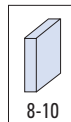
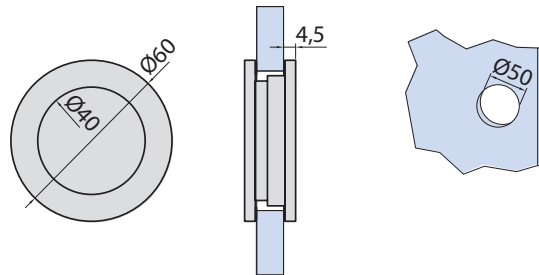

xme050



V-523

€▶ F.94

- Paio nicchie per scorrevole tonde, Ø 55
 - Pair sliding door-handles, Ø 55
 - Paar Griffmuscheln, Ø 55
- AN - NS - CR

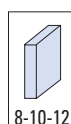
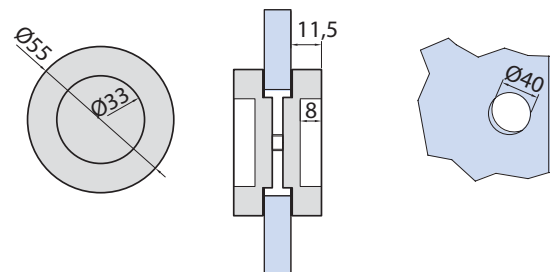

xme050



V-512-INC

- Nicchia tonda ad incollaggio per scorrevole Ø 64 - H 11
- Sliding door-handle round Ø 64 - H 11 with self adhesive
- Griffmuschel, Ø 64 - H 11 selbstklebend AN - NS

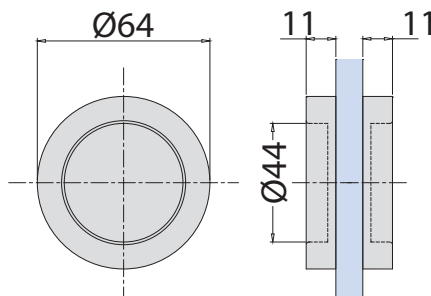

€ ▶ F.89



xfb-nicchie ad incollaggio



V-532-INC

- Nicchia scorrevole ad incollaggio biadesivo
- Sliding door-handle with self adhesive
- Griffmuschel selbstklebend AN - NS

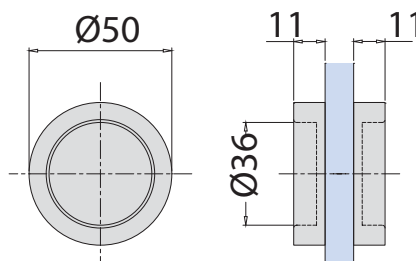

€ ▶ F.92.1



xfb-nicchie ad incollaggio



V-526

- Paio nicchie chiuse Ø 40
- Pair closed sliding-handles Ø 40
- Paar Griffmuscheln Ø 40 geschlossen AN - NS - CR

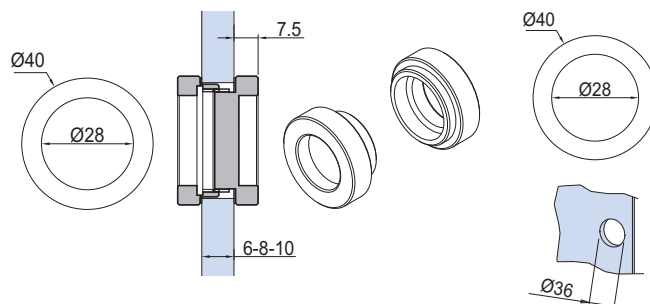

€ ▶ F.97

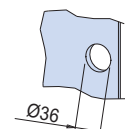
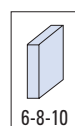



NEW
 OTTONE-BRASS

V-525

- Paio nicchie aperte Ø 40
- Pair open sliding-handles Ø 40
- Paar Griffmuscheln Ø 40 mit Glasdurchgriff
- AN - NS - CR

€ F.96

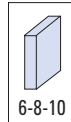
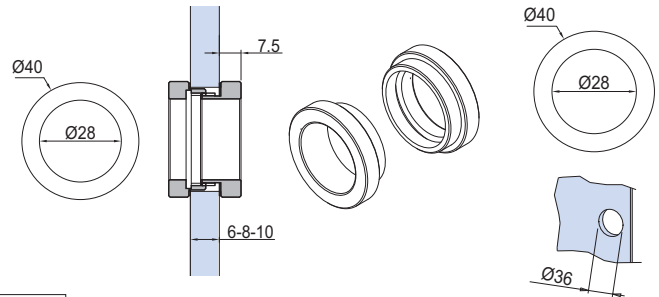

xme090



V-527

- Paio nicchie aperte Ø 30
- Pair open sliding-handles Ø 30
- Paar Griffmuscheln Ø 30 mit Glasdurchgriff
- AN - NS - CR

€ F.98

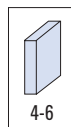
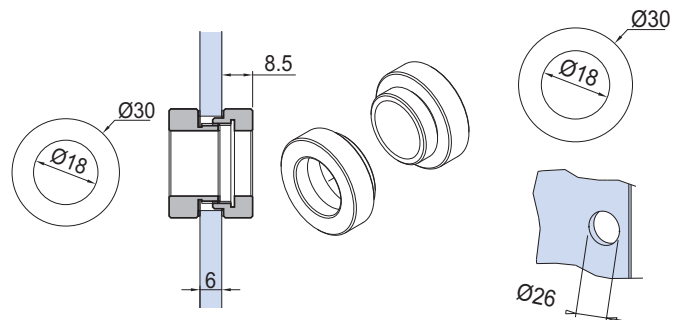

xme090



V-528

- Paio nicchie chiuse Ø 30
- Pair closed sliding-handles Ø 30
- Paar Griffmuscheln Ø 30 geschlossen
- AN - NS - CR

€ F.99

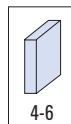
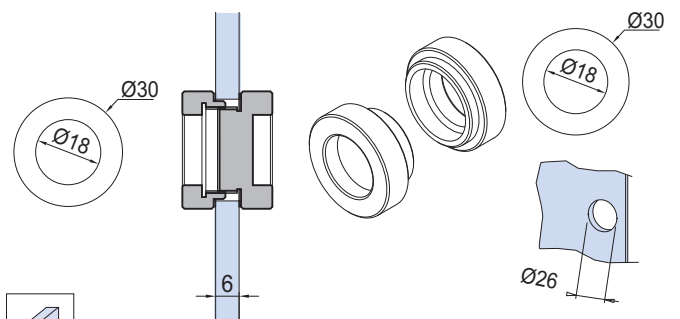

xme090

POMOLI KNOBS / KNÖPFE



V-024 25

- Coppia pomoli Ø 25 mm.
- Pair of doorknobs Ø 25 mm.
- Paar Türknöpfe Ø 25 mm.

CR - NS

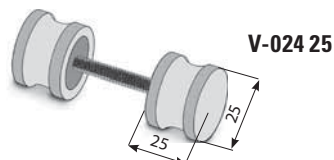

€▶ F.108 €▶ F.109
€▶ F.110 €▶ F.111

V-024 30

- Coppia pomoli Ø 30 mm.
- Pair of doorknobs Ø 30 mm.
- Paar Türknöpfe Ø 30 mm.

CR - NS

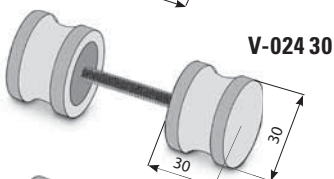

V-024 32

- Coppia pomoli Ø 32 mm.
- Pair of doorknobs Ø 32 mm.
- Paar Türknöpfe Ø 32 mm.

CR - NS

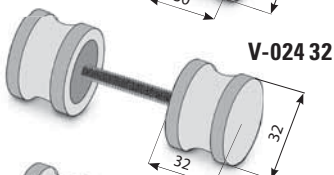

V-024 38

- Coppia pomoli Ø 38 mm.
- Pair of doorknobs Ø 38 mm.
- Paar Türknöpfe Ø 38 mm.

CR - NS

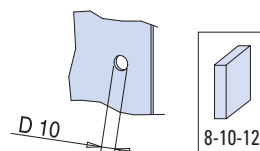
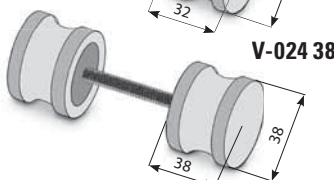

V-1107

- Coppia pomoli 35 x 35 mm foro vetro Ø 10 mm
- Pair of doorknobs 35 x 35 mm. Hole in glass 10 mm
- Paar Türknöpfe 35 x 35 mm. Glas Bohrung 10 mm

CR



€▶ F.118

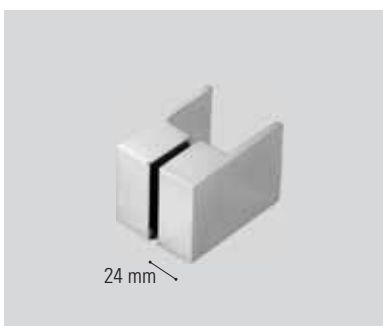
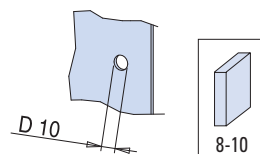

B-197

- Coppia pomoli 70 x 50 mm
- Pair of doorknobs 70 x 50 mm
- Paar Türknöpfe 70 x 50 mm

CR

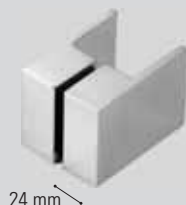

€▶ F.127

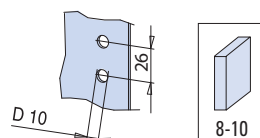

B-168

- Pomolo per porte in Zama.
- Glass doors knob Zamak.
- Paar Türknöpfe aus Zamak.

CR - NS - CP - NO

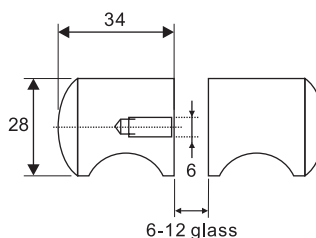

€▶ F.112

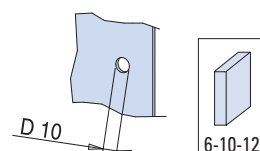



B-169

- Coppia pomoli 28 x 28 mm.
- Pair of doorknobs 28 x 28 mm.
- Paar Türknöpfe 28 x 28 mm.

CR

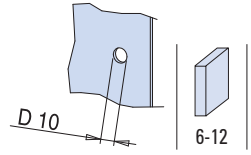
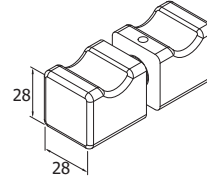
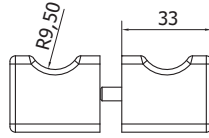

€ F.113



B-177

- Paio pomolini tondi d. 15
- Pair mini knobs d. 15
- Pair mini knobs d. 15

IL - IX

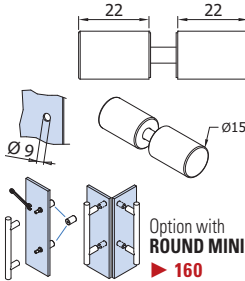

B-178

- Paio pomolini quadri q. 15
- Pair mini knobs q. 15
- Paar Knöpfe mini q.15

IL - IX

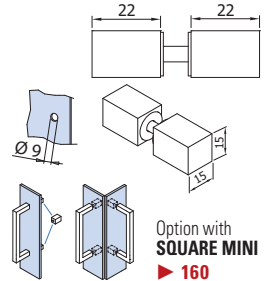

€ F.115



POR-153V

- Paio pomoli Ø 25 - H 32
- Pair knobs Ø 25 - H 32
- Paar Knöpfe Ø 25 - H 32

NS - CR

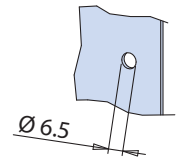
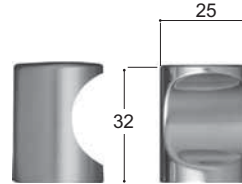

€ F.119



B-194

- Coppia pomoli Ø 32 mm - Foro vetro Ø 10 mm
- Pair of doorknobs Ø 32 mm - Hole in glass 10 mm
- Paar Türknöpfe Ø 32 mm Glas Bohrung 10 mm

CR - NS

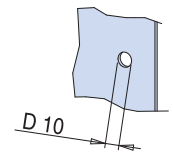

€ F.116



B-195

- Coppia pomoli 25x25 mm - Foro vetro Ø 10 mm
- Pair of doorknobs 25x25 mm - Hole in glass 10 mm
- Paar Türknöpfe 25x25 mm Glas Bohrung 10 mm

CR - NS

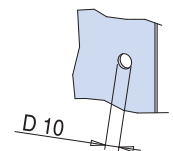

€ F.117

NS
Nickel satinato
Satin nickel
Ähnlich Edelstahl matt

CR
Cromo lucido
Polished chrome
Chrom glänzend

CS
Cromo satinato
Satin chrome
Chrom matt

OL
Ottone lucido
Polished brass
Messing poliert

CP
Cromo perla
Chrome perla similar Alu
Chrom perla ähnlich Alu

AN
Alluminio anodizzato
Aluminium anodized
Aluminium Silberfarbig

NO
Nero opaco
Matt black
Schwarz matt



V-013

- Coppia pomoli palla Ø 50 mm.
- Pair of door knobs Ø 50 mm.
- Paar Türknöpfe Ø 50 mm.

CS - NS - CR - OL

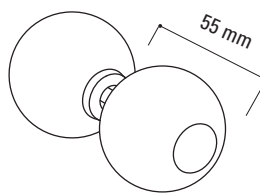

€ F.104

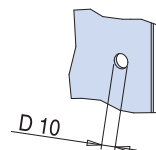

V-019

- Coppia pomoli in vetro.
- Pair of door knobs in glass.
- Paar Türknöpfe aus Glas.

NS + GLASS

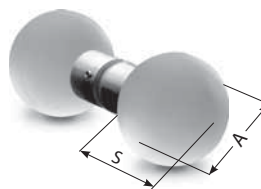

A = 40 / 45 / 50
S = 52 / 57 / 62

€ F.107

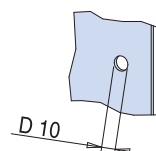

V-1056

- Coppia pomoli palla Ø 60 mm.
- Pair of door knobs Ø 60 mm.
- Paar Türknöpfe Ø 60 mm.

V-1056-2

- Coppia pomoli palla Ø 50 mm.
- Pair of door knobs Ø 50 mm.
- Paar Türknöpfe Ø 50 mm.

CS - NS - CR - OL - CP

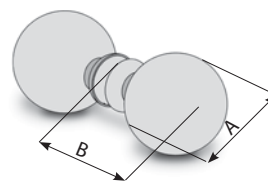

Ø 60 A = 60 / B = 78
Ø 50 A = 50 / B = 70

€ F.100 € F.101

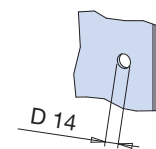

V-1056-WE

- Pomolo fisso ø 60 con rosetta filettata per montaggio su serrature "Metalglas" in abbinamento a mezza maniglia (non inclusa). Non disponibile per V-900
- Fixed knob ø 60 on threaded rosette for installation with "Metalglas" locks and turnable half handle (not included). Not available for lock V-900
- Festehender Knopf ø 60 auf Wechselstift mit Gewinderosette montierbar mit "Metalglas" Schlösser. Nicht verfügbar für V-900

CS - NS - CR - OL - CP

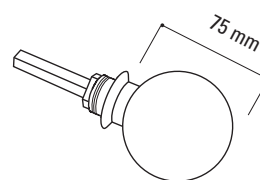

€ F.103



V-1105

- Coppia pomoli piatti Ø 55 mm.
- Pair of doorknobs Ø 55 mm.
- Paar Türknöpfe Ø 55 mm.

CS - NS - CR - OL - CP

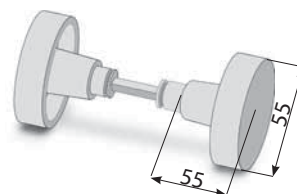

€ F.105

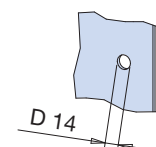



V-1105-WE

€ ▶ F.106

- Pomolo fisso Ø 55 mm con rosetta filettata per montaggio su serrature "Metalglas" in abbinamento a mezza maniglia (non inclusa)
- Fixed knob Ø 55 mm on threaded rosette for installation with "Metalglas" locks and turnable half handle (not included)
- Festehender Knopf Ø 55 mm auf Wechselstift mit "Metalglas" Schlösser

CS - NS - CR - OL - CP

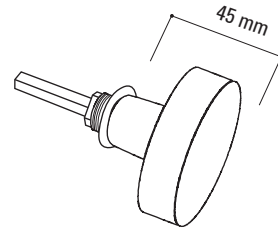

B-193

€ ▶ F.193

- Maniglietta ad incollaggio biadesivo.
- Small handle with self-adhesive fixing.
- Kleine griffe selbstklebend.

CR

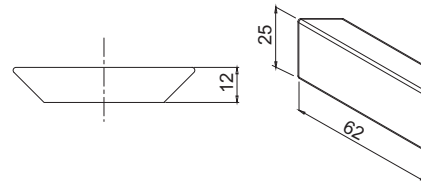

xme311



B-192

€ ▶ F.125

- Pomolo ad incollaggio biadesivo.
- Knob with self-adhesive fixing.
- Knopf selbstklebend.

CR

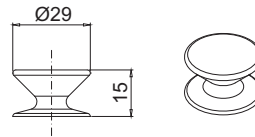

xme311



B-179

€ ▶ F.121

€ ▶ F.122

- Maniglietta ad incollaggio biadesivo, versione lunga
- Small handle with selfadhesive fixing
- Kleine griffe selbstklebend

B-180

- Maniglietta ad incollaggio biadesivo, versione corta
- Small handle with selfadhesive fixing
- Kleine griffe selbstklebend

CS - CR

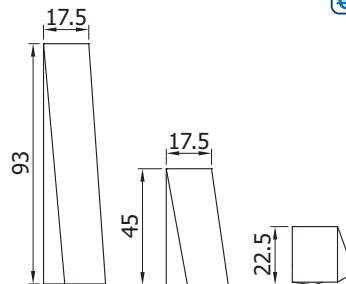

B-191-80 / B-191-240

€ ▶ F.124

- Maniglietta ad incollaggio biadesivo.
- Small handle with self-adhesive fixing.
- Kleine griffe selbstklebend.

CR



		B-191-80	B-191-240
TL	80	•	
	240		•

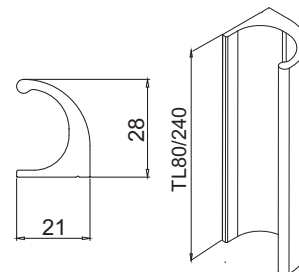

xme311

NS
Nickel satinato
Satin nickel
Ähnlich Edelstahl matt

CR
Cromo lucido
Polished chrome
Chrom glänzend

CS
Cromo satinato
Satin chrome
Chrom matt

OL
Ottone lucido
Polished brass
Messing poliert

CP
Cromo perla
Chrome perla similar Alu
Chrom perla ähnlich Alu

AN
Alluminio anodizzato
Aluminium anodized
Aluminium Silberfarbig

NO
Nero opaco
Matt black
Schwarz matt

PORTE ESTERNE
PATCH FITTINGS
GANZGLASANLAGEN



GUIDA TECNICA PER LA SCELTA DEL VOSTRO SISTEMA

TECHNICAL GUIDE FOR THE CHOICE OF YOUR SYSTEM
AUSWAHL VON SYSTEME NACH VORHANDENEN KRITERIEN

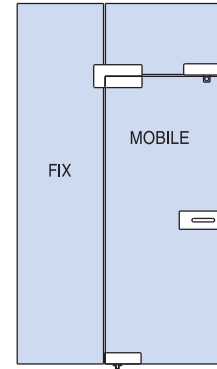
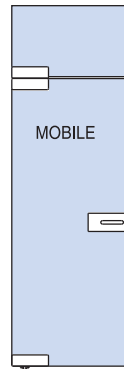
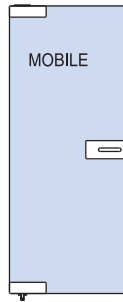

HYDRAULIC

LAM-H1006 ▶ 183
LAM-H1007 ▶ 183
V-H1012 ▶ 184



HYDRAULIC

LAM-H1006 ▶ 183
LAM-H1007 ▶ 183
V-H1012 ▶ 184



HYDRAULIC

LAM-H1006 ▶ 183
LAM-H1007 ▶ 183
V-H1012 ▶ 184



X SERIE

XC-020 ▶ 204
XC-010 ▶ 204



X SERIE

XCS-020B ▶ 204
XC-020 ▶ 204
XC-010 ▶ 204



X SERIE

XC-040 ▶ 204
XC-020 ▶ 204
X-480B ▶ 205
XC-010 ▶ 204



X SERIE MINI

XD-020 ▶ 209
X-440 ▶ 205



X SERIE MINI

XDS-020B ▶ 209
XD-020 ▶ 209
XD-440 ▶ 209



MODULO QUADRO

XC-040 ▶ 204
XC-020 ▶ 204
X-480B ▶ 205
XC-010 ▶ 204



MODULO QUADRO

MQ-1 ▶ 192
MQ-2T ▶ 192



MODULO QUADRO

MQ-13 ▶ 193
MQ-11 ▶ 192
MQ-2T ▶ 192



MODULO TONDO

M1-SET ▶ 197
M13 ▶ 199
M2-T ▶ 198



MODULO TONDO

M1 ▶ 198
M2-T ▶ 198



MODULO TONDO

M11-L/R ▶ 199
M1 ▶ 199
M2-T ▶ 198



**MODULO QUADRO
PER FORTI SPESSORI
HINGES FOR GLASS
THICKNESS
BÄNDER FÜR
GLASDICKE
17,5 - 21,5 mm**

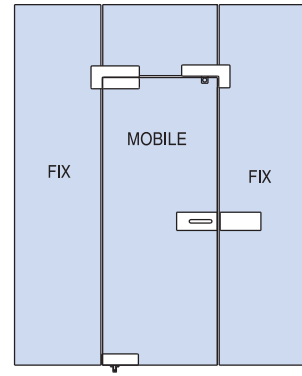
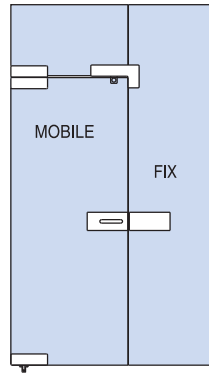
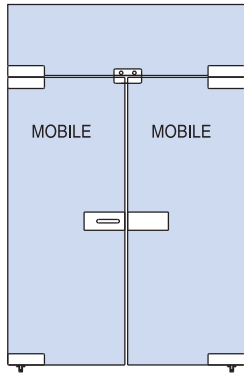

MQFS-2T ▶ 187
MQFS-1 ▶ 187

HYDRAULIC

LAM-H1006 ▶ 183

LAM-H1007 ▶ 183

V-H1012 ▶ 184

HYDRAULIC

LAM-H1006 ▶ 183

LAM-H1007 ▶ 183

V-H1012 ▶ 184

HYDRAULIC

LAM-H1006 ▶ 183

LAM-H1007 ▶ 183

V-H1012 ▶ 184

X SERIE

XCS-020B ▶ 204

XC-020 ▶ 204

X-480B ▶ 205

XC-010 ▶ 204

X SERIE

XCS-020B ▶ 204

XC-020 ▶ 204

X-470B ▶ 205

XC-010 ▶ 204

X SERIE

XC-040 ▶ 204

XC-020 ▶ 204

X-470B ▶ 205

XC-010 ▶ 204

X SERIE MINI

XDS-020B ▶ 209

XD-020 ▶ 209

X-480B ▶ 205

XD-440 ▶ 209

MODULO QUADRO

MQ-13 ▶ 193

MQ-11 ▶ 192

MQ-17 ▶ 195

MQ-2T ▶ 192

MODULO QUADRO

MQ-6 ▶ 193

MQ-11 ▶ 192

MQ-4 ▶ 193

MQ-2T ▶ 192

MODULO QUADRO

MQ-13 ▶ 193

MQ-11 ▶ 192

MQ-17 ▶ 195

MQ-2T ▶ 192

MODULO TONDO

M11-L/R ▶ 199

M1 ▶ 198

M14 ▶ 199

M2-T ▶ 198

MODULO TONDO

M1-SET ▶ 197

M13 ▶ 199

M2-T ▶ 198

MODULO TONDO

M11-L/R ▶ 199

M1 ▶ 198

M13 ▶ 199

M2-T ▶ 198



- ACCESSORI
- ACCESSORIES
- ZUBEHÖRE

CHIUDIPIANTA A PAVIMENTO

DOOR CLOSER

BODENTURSCHLIESSER

▶ 222

ANTIK

▶ 212

SERRATURE PER FORTI SPESSORI

 LOCKS FOR GLASS THICKNESS
 SCHLÖSSER FÜR GLASDICKE
 17,5 - 21,5 mm

ELEGANT FS ▶ 188



CERNIERE INFERIORI OLEODINAMICHE

HYDRAULIC BOTTOM HINGES / HYDRAULISCHE UNTERE BÄNDER

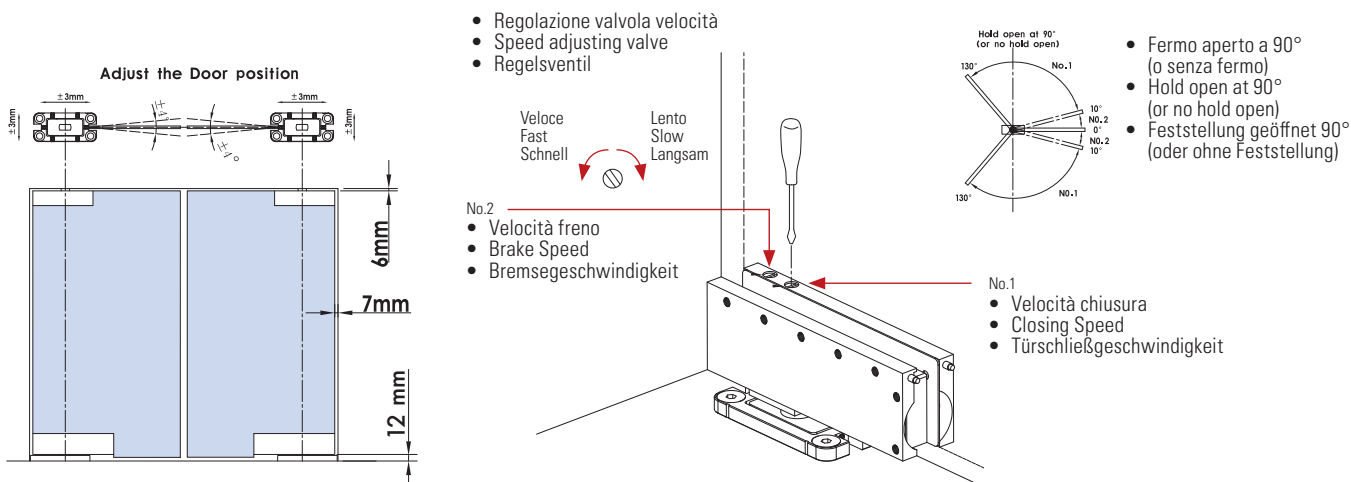

LAM-H1006

- Cerniera inferiore oleodinamica con chiudiporta integrato, stop a 0° + 90° -90°.
- Hydraulic bottom hinge with integrated door closer stop at 0° + 90° -90°.
- Unteres Hydraulikband mit Einstellung der Türschließgeschwindigkeit Stop zu 0°, +90°, -90°.

IX-AN

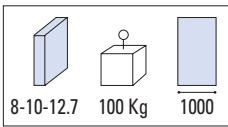
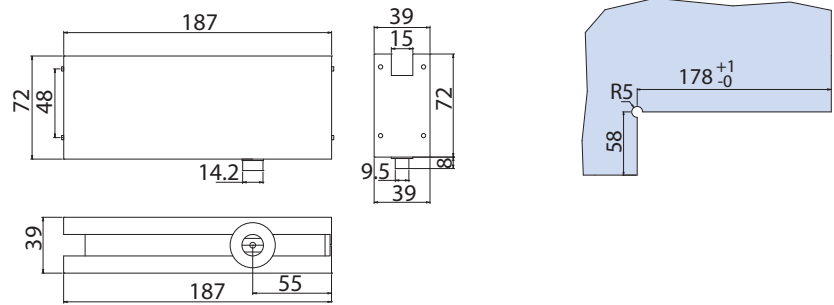

xme338



LAM-H1007

- Cerniera inferiore oleodinamica con chiudiporta integrato, stop a 0° + 90° -90°.
- Hydraulic bottom hinge with integrated door closer stop at 0° + 90° -90°.
- Unteres Hydraulikband mit Einstellung der Türschließgeschwindigkeit Stop zu 0°, +90°, -90°.

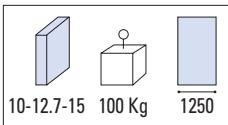
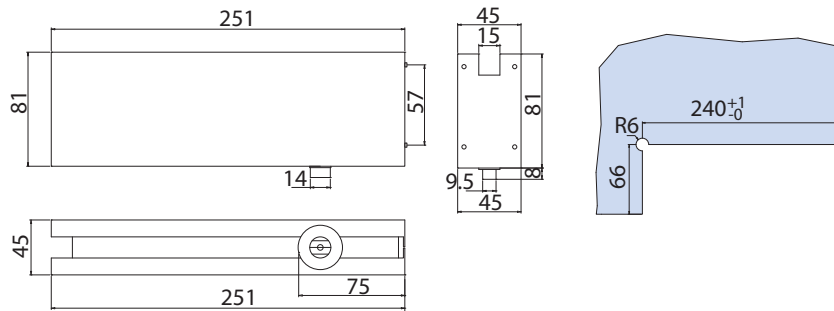
IX

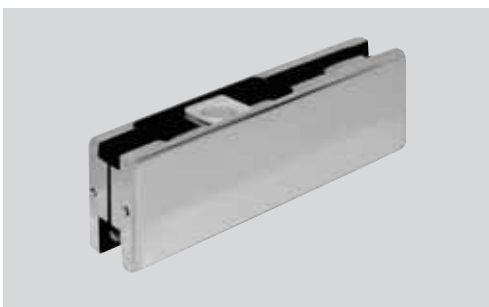

xme338

LAM-H1008

- Cerniera superiore registrabile con copertine di misure come LAM-H1006.
- Top patch adjustable with cover plate's size same as LAM-H1006.
- Oberer Eckbeschlag, Abdeckungen wie LAM-H1006 mit verstellbarem Lager.

IX-AN

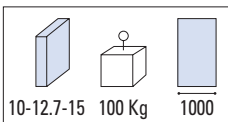
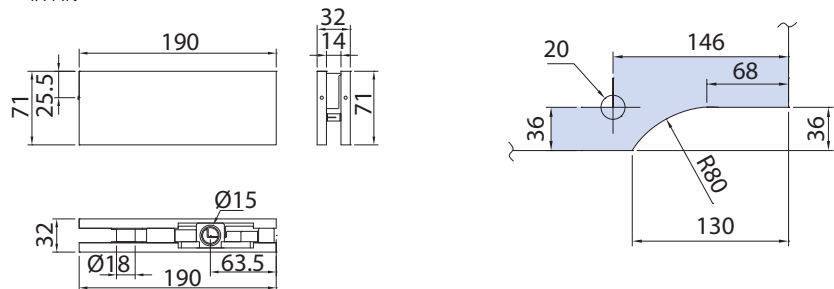

xme381

LAM-H1000

- Perno superiore per LAM-H1008.
- Top pin for LAM-H1008.
- Oberer Zapfen für LAM-H1008.

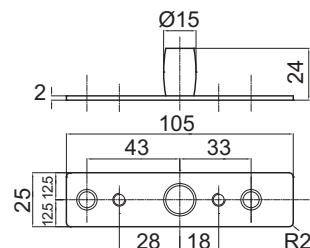

xla117

CERNIERE OLEODINAMICHE "OLLY" HYDRAULIC HINGES "OLLY" / HYDRAULISCHE BÄNDER "OLLY"



V-H1012

- Cerniera inferiore oleodinamica con chiudiporta integrato, stop a 0° +90° -90°.
- Hydraulic bottom hinge with integrated door closer stop at 0° +90° -90°.
- Unteres Hydraulikband mit Einstellung der Türschließgeschwindigkeit Stop zu 0°, +90°, -90°.

€ ▶ G.06

IX

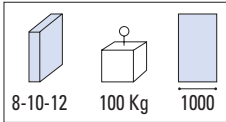
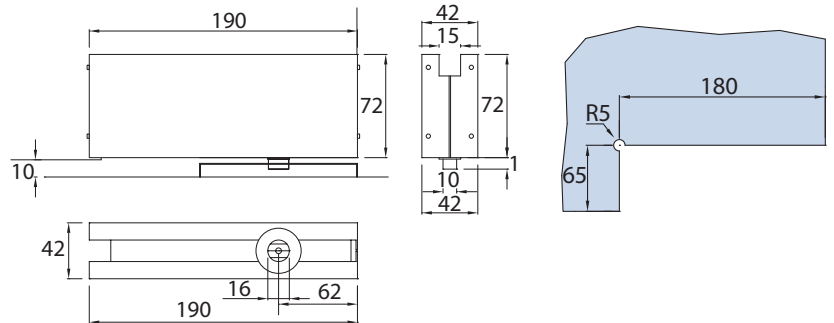

xme560



V-H1013

- Cerniera superiore registrabile con copertine di misure come LAM-H1012, perno superiore incluso.
- Top patch adjustable with cover plate's size same as LAM-H1012, top pin included.
- Oberer Eckbeschlag, Abdeckungen wie LAM-H1012 mit verstellbarem Lager, oberer Zapfen enthalten.

€ ▶ G.07

IX

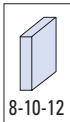
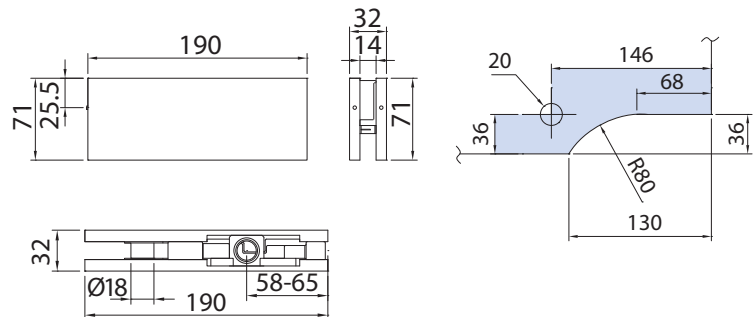

xme381



MODULO QUADRO PER FORTI SPESSORI 17,5 - 21,5 mm
HINGES FOR GLASS THICKNESS 17,5 - 21,5 mm / BÄNDER FÜR GLASDICKE 17,5 - 21,5 mm

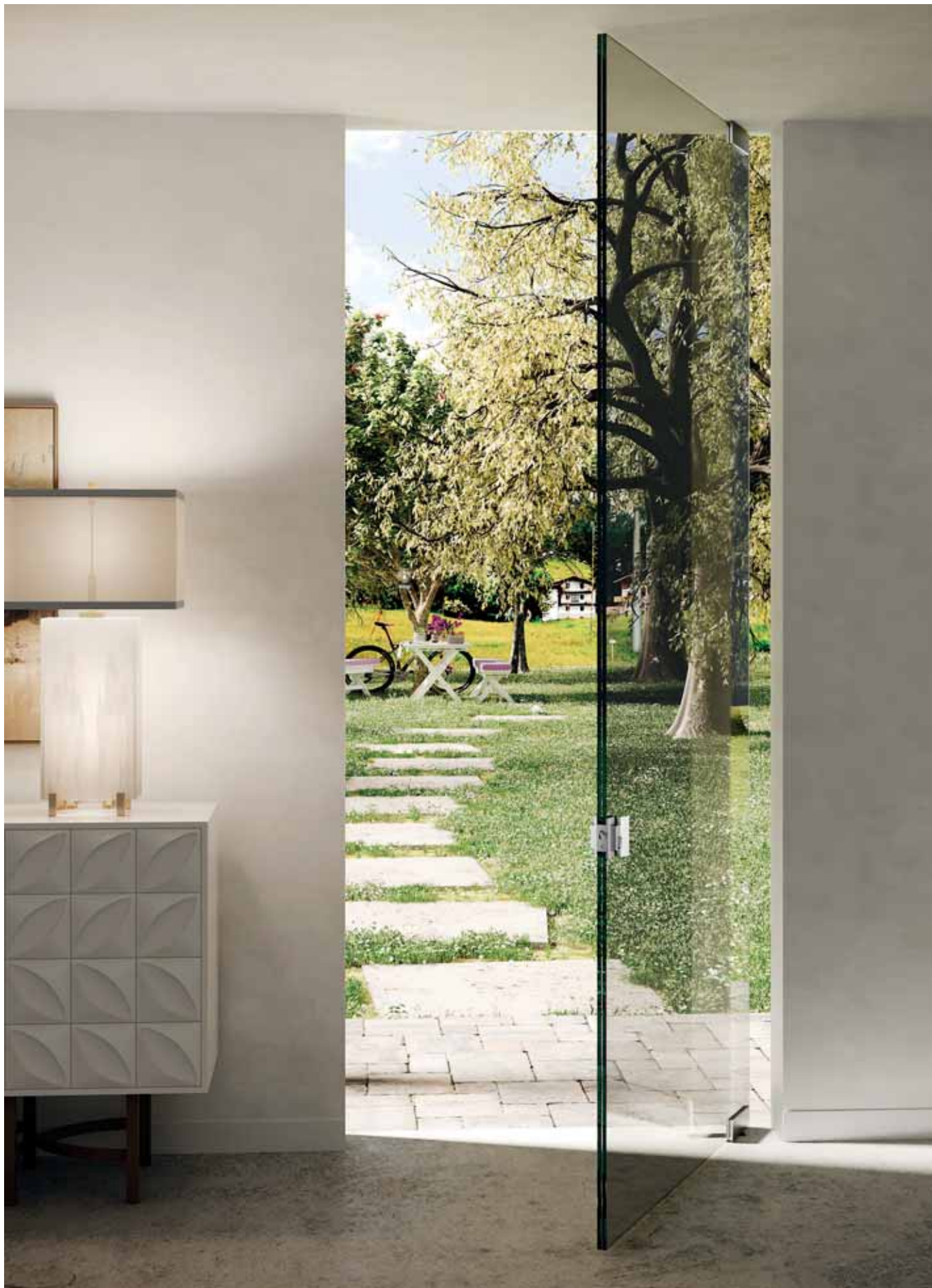

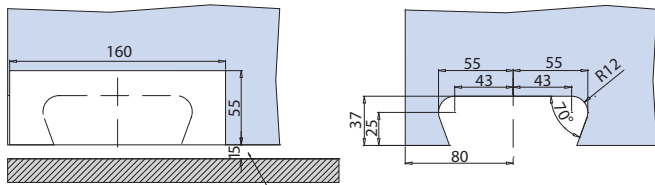
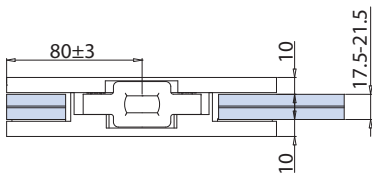
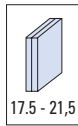

MQFS-2T €► G.09

- Cerniera inferiore in acciaio inox AISI 316
- Bottom hinge stainless steel AISI 316
- Unteres Band aus Edelstahl AISI 316

MQFS-1 €► G.10

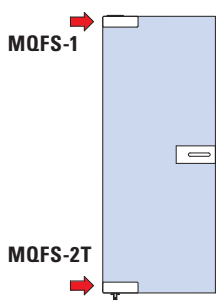
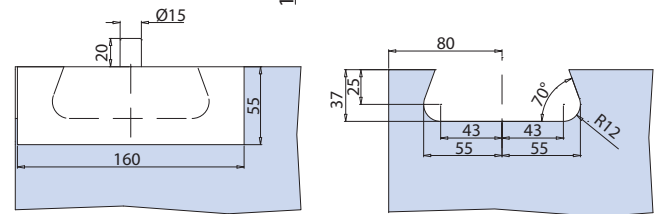
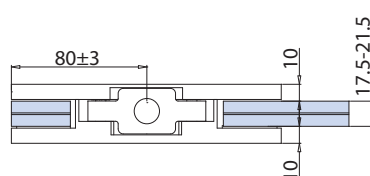
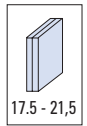
- Cerniera superiore in acciaio inox AISI 316
- Top hinge stainless steel AISI 316
- Oberes Band aus Edelstahl AISI 316



- Lavorazione per installazione cerniera filo vetro
- Glass preparation hinge flush with the glass border
- Glasbearbeitung Band bündig mit Glaskante



- Serrature V-725 / V-745 disponibili per forti spessori 13,5 - 17,5 - 21,5 mm
- Locks V-725 / V-745 available for thickness 13,5 - 17,5 - 21,5 mm
- Schlösser V-725 / V-745 für Glasdicke 13,5 - 17,5 - 21,5 mm verfügbar

► 188

xme 491

MQFS-7 €► G.11

- Pozzetto superiore
- Top socket
- Deckenbuchse

IX

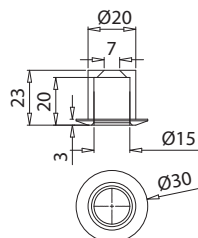
XT-83 B €► G.12

- Perno a pavimento con quadro tedesco ovale
- Floor pivot with German profile spindle
- Bodenbuchse mit flachkonischer Achse

IX

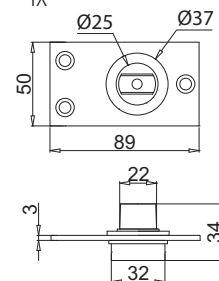

gpe 012

IX
Acciaio inox satinato
Satin stainless steel
Edelstahl matt

IL
Acciaio inox lucido
Polished stainless steel
Edelstahl poliert

ELEGANT LEVER FS



V-745-13,5 PZ
V-745-17,5 PZ
V-745-21,5 PZ

€► G.13

- Serrature Elegant con chiavistello tondo, per vetri con spessori 13,5 - 17,5 - 21,5. Impugnatura Leva incorporata.
- Locks Elegant with rounded dead bolt, for glass thickness 13,5 - 17,5 - 21,5. Lever handle incorporated.
- Cylinders and strike plates not included, to order separately.
- Elegant Mittelschloss mit Bolzen, für Glasdicke 13,5 - 17,5 - 21,5. Griff angebaut.
- Zylinder und Schließbleche nicht enthalten, separat zu bestellen.



€► G.14

V-745-13,5 2FLG
V-745-17,5 2FLG
V-745-21,5 2FLG

- Controserrature
- Strike boxes
- Gegenkästen

C-024

€► G.16

- Cilindro simmetrico da 70 mm.
- Cylinder symmetrical length 70 mm.
- Zylinder symmetrisch mit Länge 70 mm.

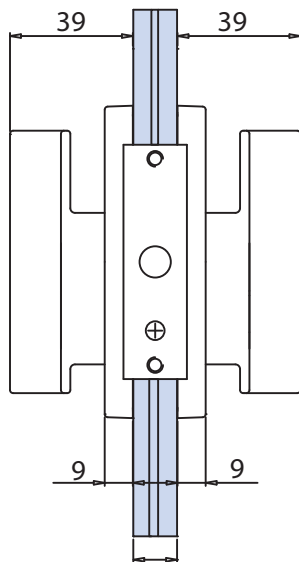
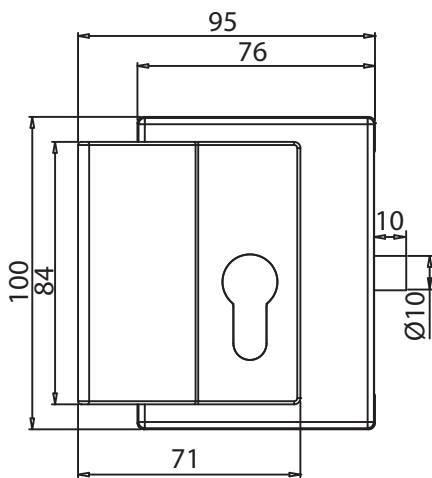
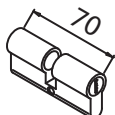

V-745-13,5 vetro/glass 13,5 mm
V-745-17,5 vetro/glass 17,5 mm
V-745-21,5 vetro/glass 21,5 mm

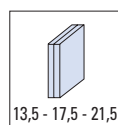
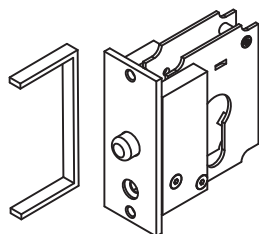

LAVORAZIONE VETRO
GLASS PREPARATION
GLASBEARBEITUNG

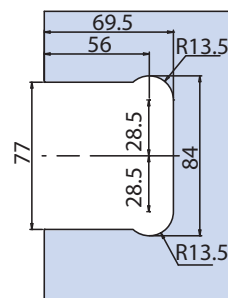

V-745-13,5 2FLG
V-745-17,5 2FLG
V-745-21,5 2FLG

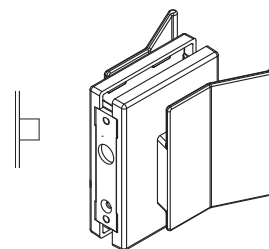

V-023 €► G.15

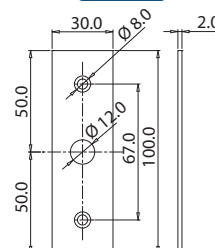

xme 490a

NS

Nickel satinato
Satin nickel
Ähnlich Edelstahl matt

ELEGANT FS



V-725-13,5 PZ
V-725-17,5 PZ
V-725-21,5 PZ

€▶ G.17

- Serrature Elegant con chiavistello tondo, per vetri con spessori 13,5 - 17,5 - 21,5. Cilindri e contropiastre da ordinare a parte.
- Locks Elegant with rounded dead bolt, for glass thickness 13,5 - 17,5 - 21,5. Cylinders and strike plates not included, to order separately.
- Elegant Mittelschloss mit Bolzen, für Glasdicke 13,5 - 17,5 - 21,5. Zylinder und Schließbleche nicht enthalten, separat zu bestellen.



V-725-13,5 2FLG
V-725-17,5 2FLG
V-725-21,5 2FLG

- Controserrature
- Strike boxes
- Gegenkästen

€▶ G.18

C-06

€▶ G.20

- Cilindro simmetrico da 45 mm.
- Cylinder symmetrical length 45 mm.
- Zylinder symmetrisch mit Länge 45 mm.

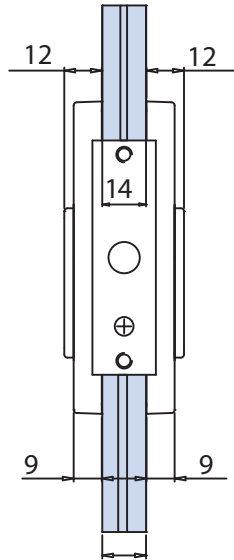
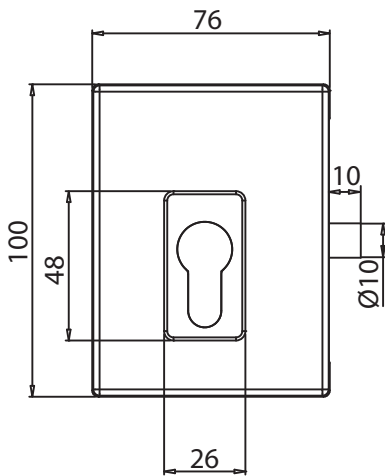
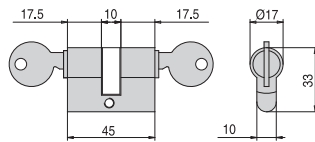

V-745-13,5 vetro/glass 13,5 mm
V-745-17,5 vetro/glass 17,5 mm
V-745-21,5 vetro/glass 21,5 mm

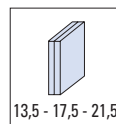
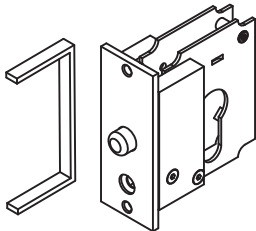

LAVORAZIONE VETRO
 GLASS PREPARATION
 GLASBEARBEITUNG

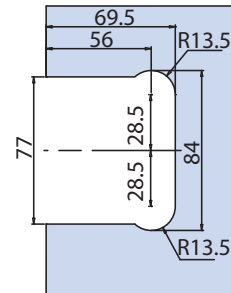

V-725-13,5 2FLG
V-725-17,5 2FLG
V-725-21,5 2FLG

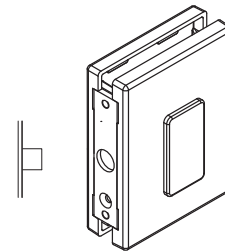

V-023 €▶ G.19

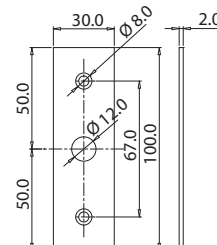

xme 490a

NS
 Nickel satinato
 Satin nickel
 Ähnlich Edelstahl matt

MODULO QUADRO

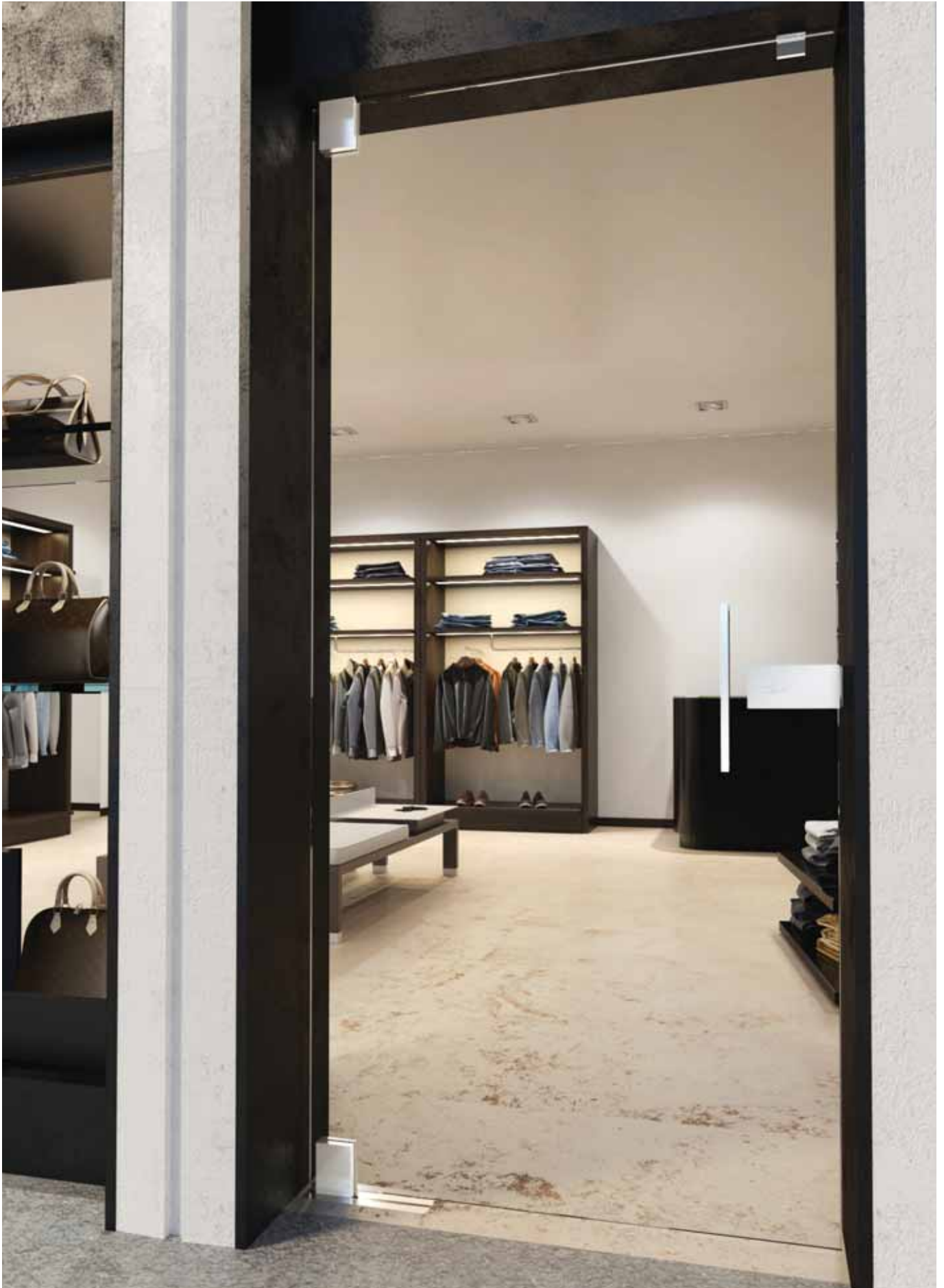

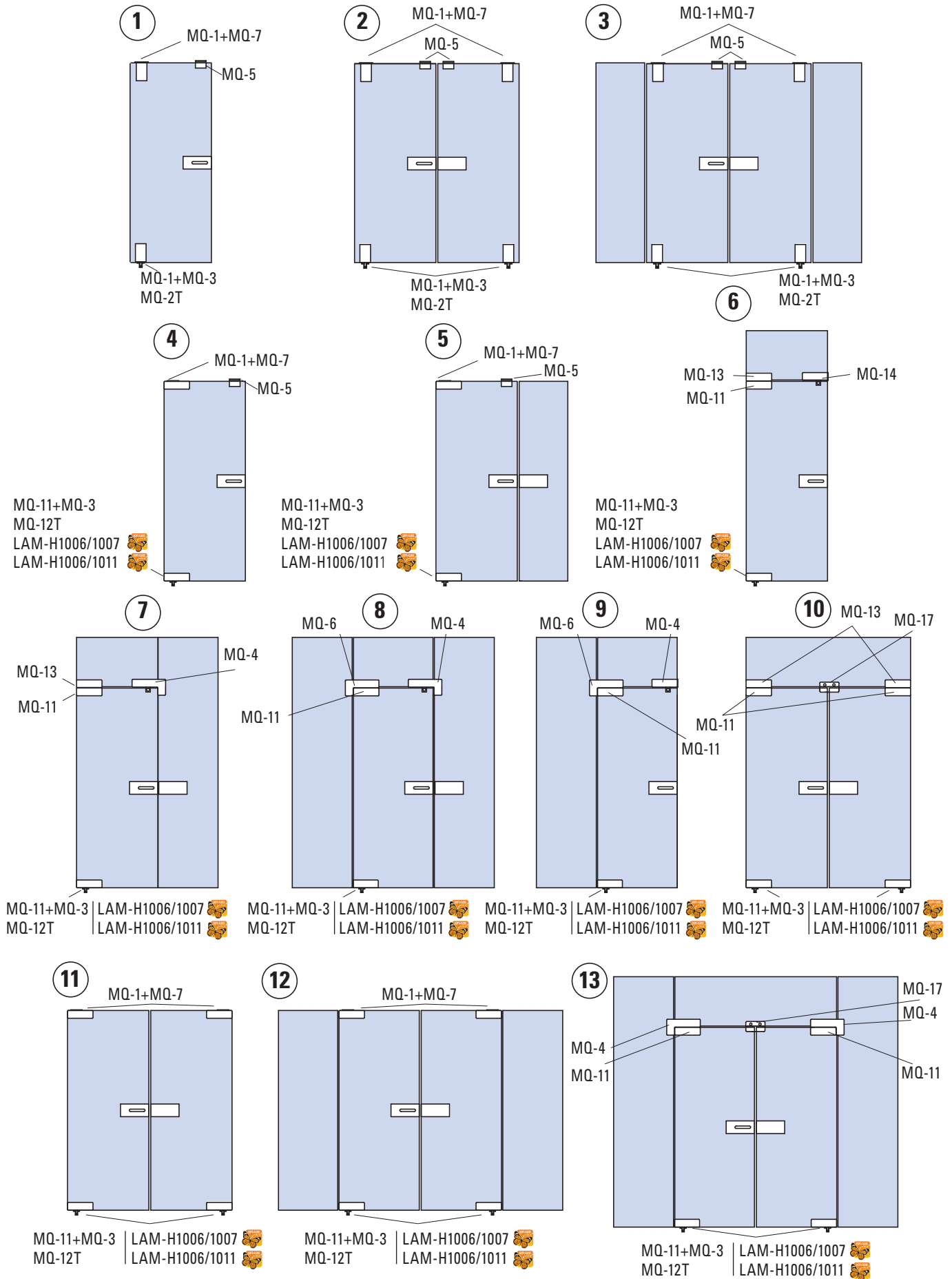
TIPOLOGIA DI APPLICAZIONE / APPLICATION TYPOLOGIES / KOMPOSITIONSMÖGLICHKEITEN DES SYSTEM



MQ-1 €► G.21

- Cerniera inferiore/superiore.
 - Top/bottom patch.
 - Oberes/Unteres Pendeltürband.
- CR - NS

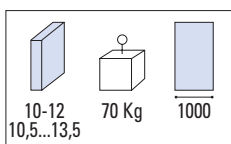
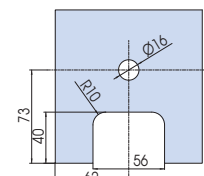
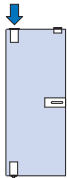
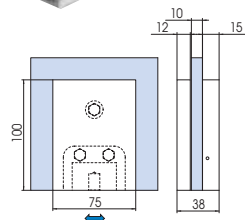

xla269



MQ2-I €► G.22

- Cerniera inferiore per pompa Italia.
 - Bottom pivot hinge for square closer.
 - Unteres Pendeltürband für Bodentürschließer mit Vierkant.
- CR - NS

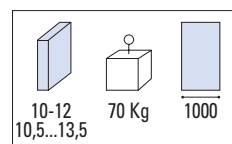
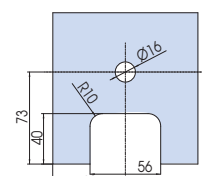
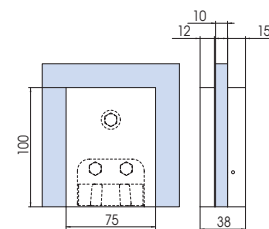

xla269



MQ-2-T €► G.23

- Cerniera inferiore per pompa Tedesca.
 - Bottom pivot hinge for german closer.
 - Unteres Pendeltürband für Bodentürschließer mit flachkonischer Achse.
- CR - NS

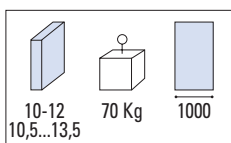
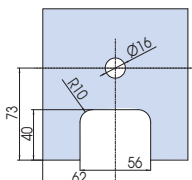
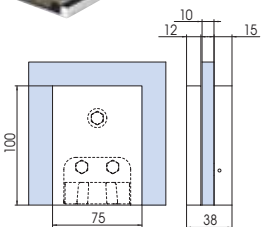

xla269



MQ-11 €► G.24

- Cerniera inferiore/superiore registrabile.
 - Top/Bottom patch with regulation.
 - Oberer/Unterer Eckbeschlag mit verstellbarem Lager.
- CR - NS

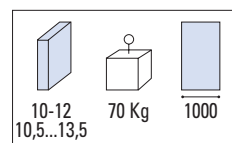
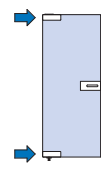
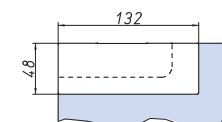
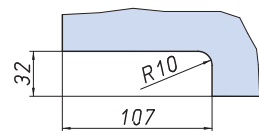
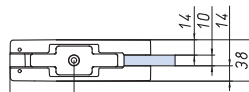

xla268a



MQ-12-I €► G.26

- Cerniera inferiore per pompa Italia.
 - Bottom pivot hinge for square closer.
 - Unteres Pendeltürband für Bodentürschließer mit Vierkant.
- CR - NS

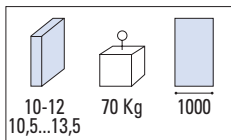
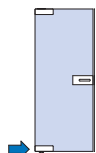
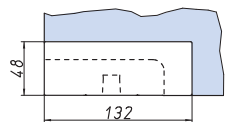
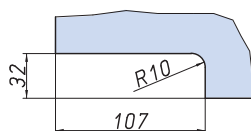
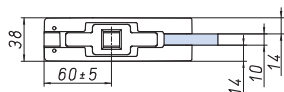

xme268a



MQ-12-T €► G.25

- Cerniera inferiore per pompa Tedesca.
 - Bottom pivot hinge for german closer.
 - Unteres Pendeltürband für Bodentürschließer mit flachkonischer Achse.
- CR - NS

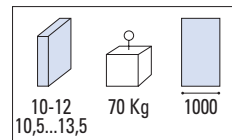
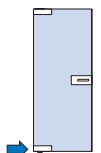
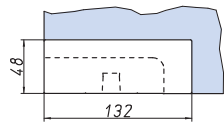
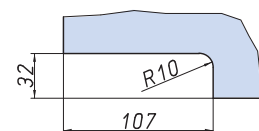
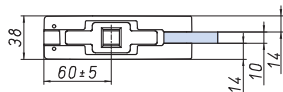

xla268a

MQ-13

€ ▶ G.27

- Cerniera con attacco sopra luce/muro perno mm 10.
- Overpanel patch with pivot 10 mm and wall plate.
- Oberlichtbeschlag mit Zapfen 10 mm. und Befestigungsglasche CR - NS

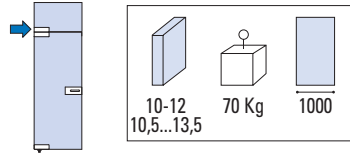
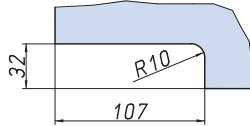
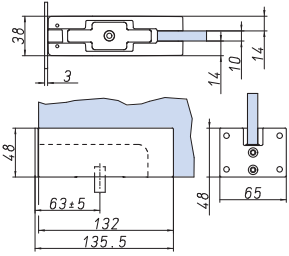

xla268a-1

MQ-6

€ ▶ G.28

- Cerniera con attacco sopra luce vetro fisso perno mm 10.
- Patch for overpanel and side panel with pivot 10 mm.
- Winkeloberlichtbeschlag mit Zapfen mm 10. CR - NS

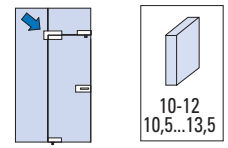
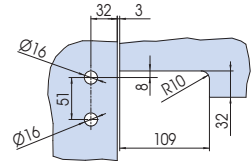
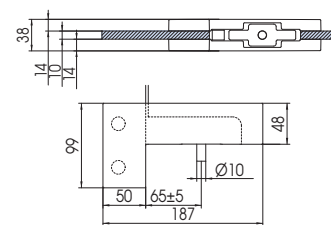

xla268c

MQ-4

€ ▶ G.29

- Cerniera con attacco sopra luce vetro fisso con battuta.
- Patch for overpanel and side panel with stop.
- Winkeloberlichtbeschlag mit Anschlag. CR - NS

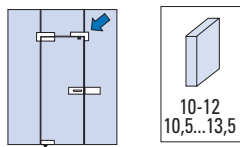
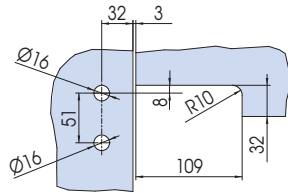
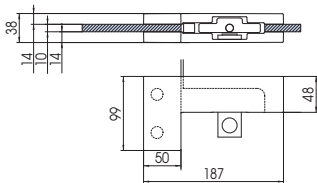

xla268c-1

MQ-8

€ ▶ G.30

- Cerniera con attacco sopra luce vetro fisso con inserto cieco.
- Patch for overpanel and side panel with blind insert.
- Winkeloberlichtbeschlag mit Blindeinsatz. CR - NS

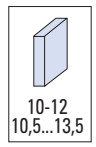
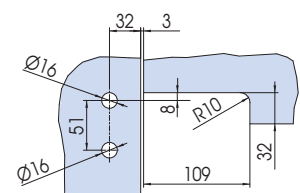
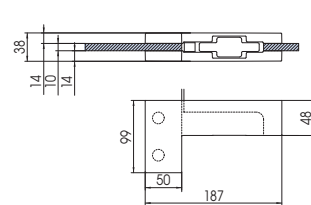

xla268c-1

MQ-14

€ ▶ G.31

- Cerniera sopra luce/muro con battuta.
- Overpanel patch with stop and wall plate.
- Oberlichtbeschlag mit Anschlag und Befestigungsglasche. CR - NS

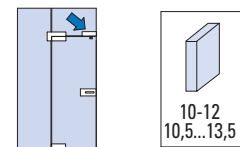
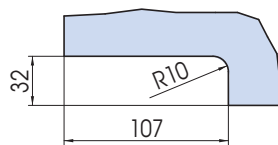
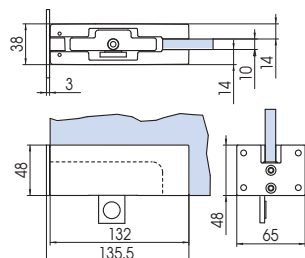

xla268b-1

MQ-16

€ ▶ G.32

- Cerniera regolabile con attacco a sopra luce e fisso laterale.
- For overpanel and side panel.
- Winkeloberlichtbeschlag. CR - NS

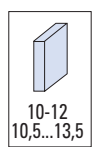
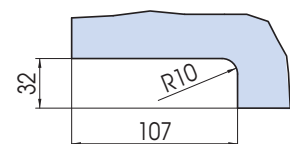
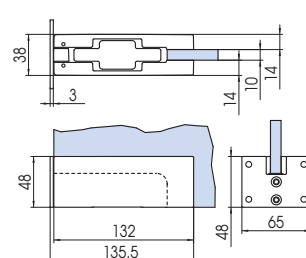

xla268b



MQ-5 € ▶ G.34

- Battuta per porta singola.
- Single-stop with ceiling installation.
- Anschlag für Deckenbefestigung 1-flg. CR - NS

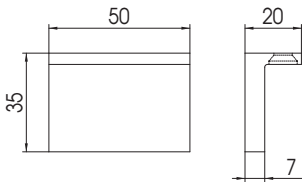

xla268d



MQ-3 € ▶ G.33

- Pozzetto inferiore con perno regolabile per MQ-1, MQ-11.
- Floor installation bottom pivot ball-bearing for MQ-1, MQ-11.
- Bodenbuchse Kugelgelagert für MQ-1, MQ-11. NS

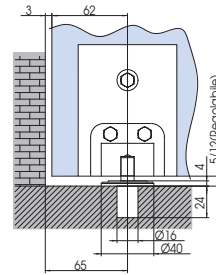

xla268d



MQ-7 € ▶ G.35

- Perno superiore rettangolare.
- Rectangular top pin.
- Oberer zapfen eckig.

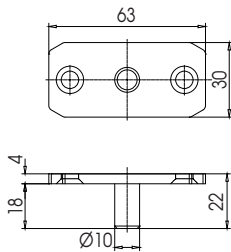

xla268d



MQ-10 € ▶ G.39

- Battuta per porta doppia.
- Double stop with ceiling installation.
- Doppelteranschlag für Deckenbefestigung 2-flg. CR - NS

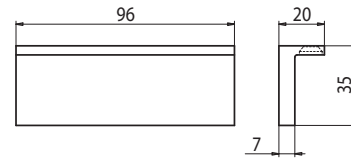

xla232



MQ-9 € ▶ G.37

- Supporto vetro fisso.
- Wall connector.
- Wandhalter. CR - NS

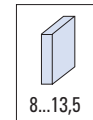
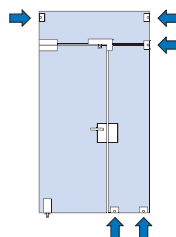
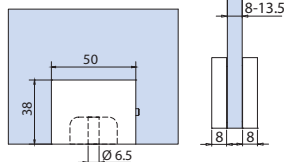
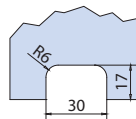

xme292-1



MQ-15 € ▶ G.38

- Morsetto per aggancio due vetri.
- Connector.
- Verbindungsbeschlag. CR - NS

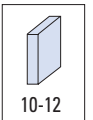
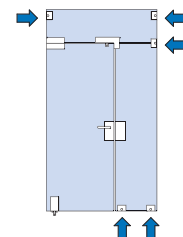
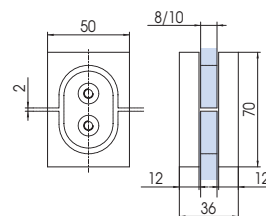
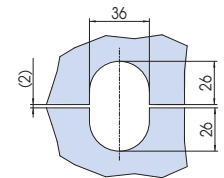

xla268e

MQ-17

- Battuta per porta doppia con attacco a sopra luce.
- Double stop fixed on overpanel.
- Doppelanschlag am Oberlicht. CR - NS

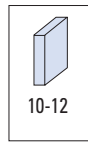
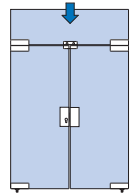
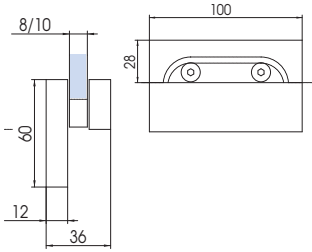
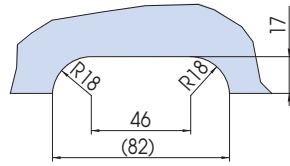

xla268e

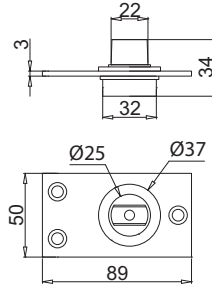

XT-83 B

- Perno a pavimento con quadro tedesco ovale.
- Floor pivot with German profile spindle.
- Bodenbuchse mit flachkonischer Achse.

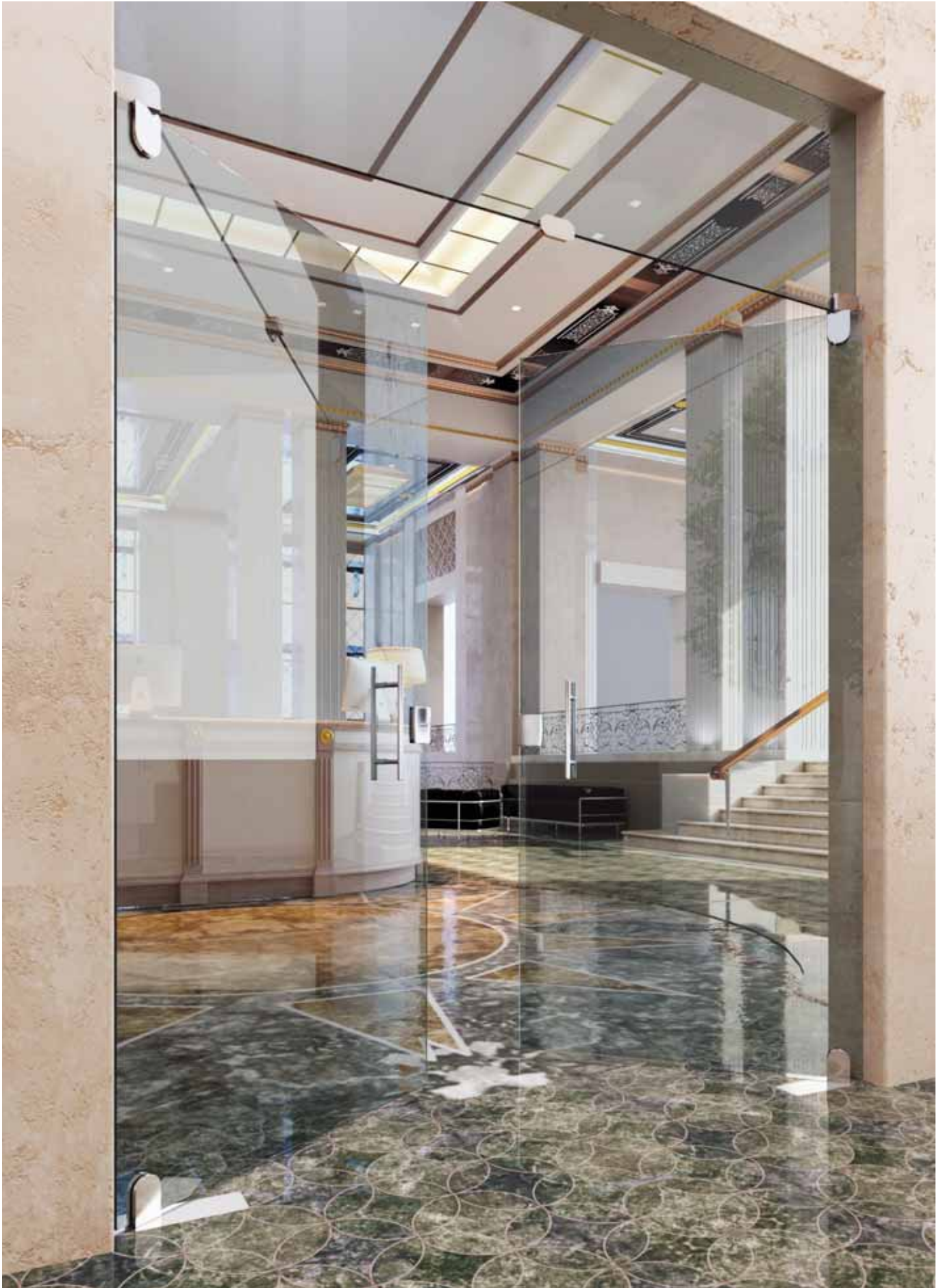

gpe012

MODULO TONDO

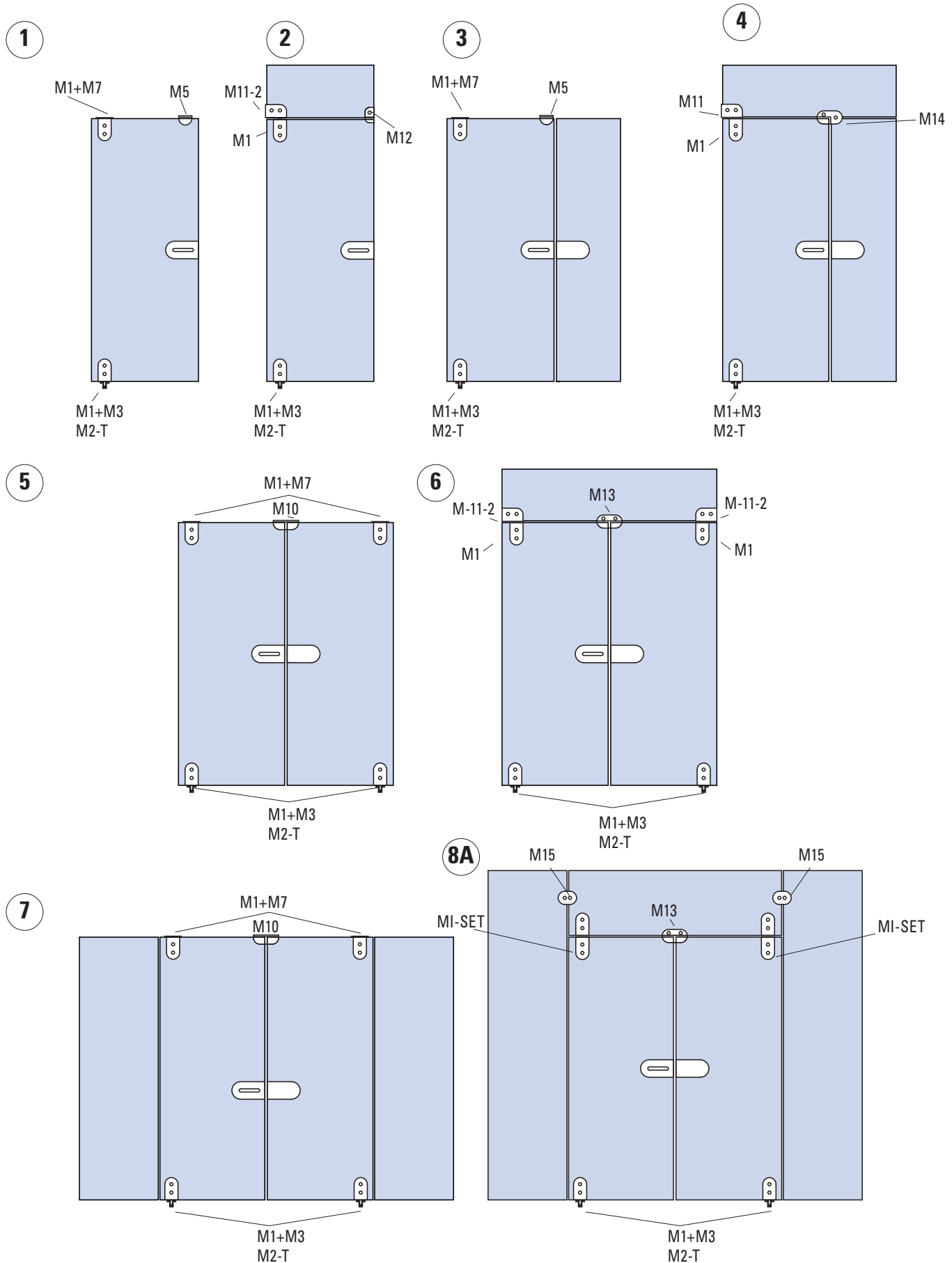

TIPOLOGIA DI APPLICAZIONE / APPLICATION TYPOLOGIES / KOMPOSITIONSMÖGLICHKEITEN DES SYSTEM



M1 €► G.42

- Cerniera inferiore / superiore.
- Top / bottom patch.
- Oberes / Unteres Pendeltürband.

NS

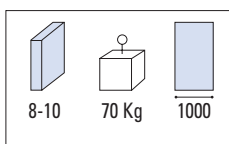
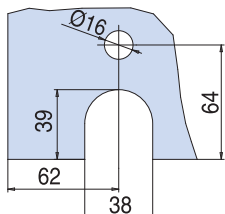
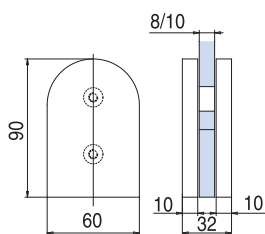

xla76-1



M2-I €► G.43

- Cerniera inferiore per pompa Italia.
- Bottom pivot hinge for square closer.
- Unteres Pendeltürband für Bodentürschließer mit Vierkant.

NS

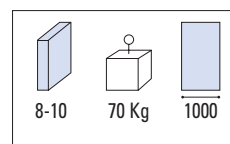
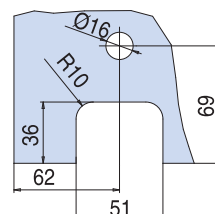
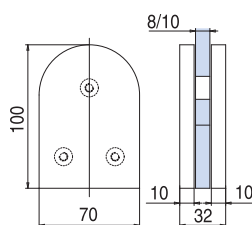

xla76



M2-T €► G.44

- Cerniera inferiore per pompa Tedesca.
- Bottom pivot hinge for german closer.
- Unteres Pendeltürband für Bodentürschließer mit flachkonischer Achse.

NS

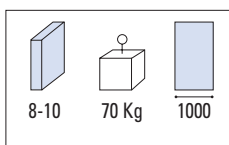
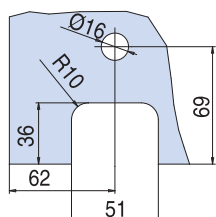
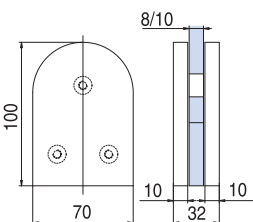

xla76



M3 €► G.45

- Pozzetto inferiore con perno regolabile.
- Floor installation bottom pivot ball bearing.
- Bodenbuchse kugelgelagert zum Einlassen in Mauerwerk.

NS

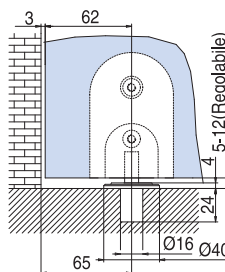

xla77



M5 €► G.47

- Battuta per porta singola.
- Single stop with ceiling installation.
- Anschlag für Deckenbefestigung 1-flg.

NS

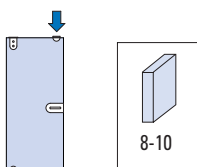
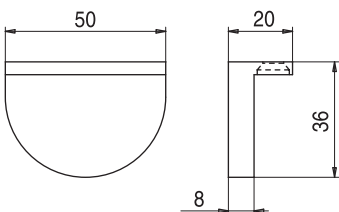

xla78



MQ-7 €► G.46

- Perno superiore rettangolare.
- Rectangular top pin.
- Oberer Zapfen eckig.

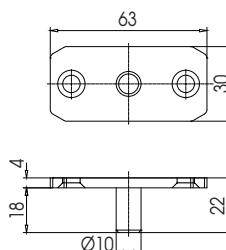

xla268d

M-10

- Battuta per porta doppia.
- Double stop with ceiling installation.
- Anschlag für Deckenbefestigung 2-flg.

NS

▶ G.48

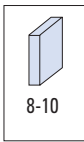
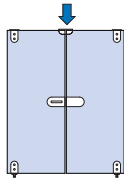
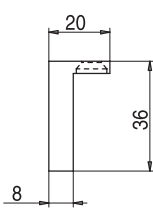
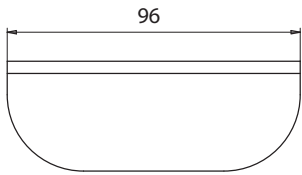

xla78

M11-R

- Cerniera per rotazione laterale con attacco a sopra luce destro.
- Double Link fitting for transom to wall right.
- Kupplung Oberlicht - Wand rechts.

NS

▶ G.55

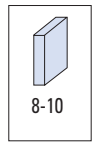
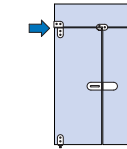
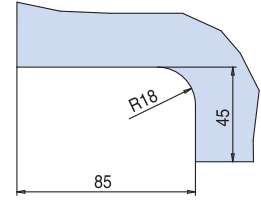
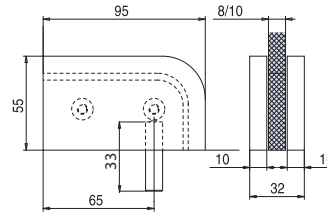

xla81-1

M11-L

- Cerniera per rotazione laterale con attacco a sopra luce sinistro.
- Link fitting for transom to wall left.
- Kupplung Oberlicht - Wand links.

NS

▶ G.56

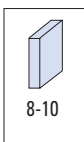
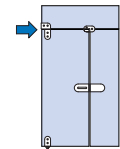
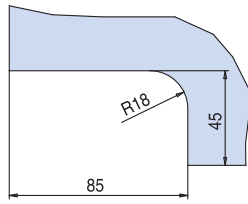
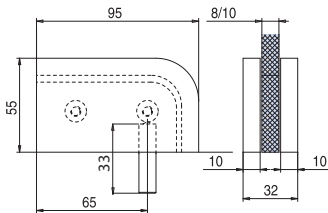

xla81-1

M12

- Battuta per porta singola con attacco a sopra luce.
- Stop fixed on overpanel left/right.
- Anschlag fest am Oberlicht links/rechts.

NS

▶ G.57

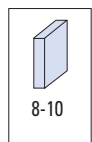
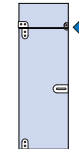
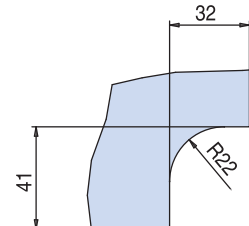
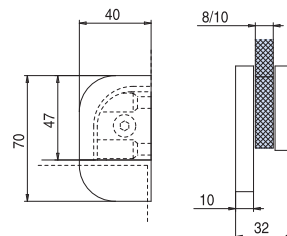

xla81-1

M13

- Battuta per porta doppia con attacco per sopra luce.
- Double stop fixed on overpanel.
- Doppelter Anschlag, fest am Oberlicht.

NS

▶ G.52

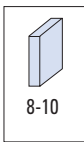
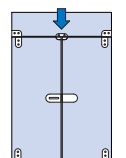
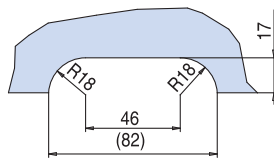
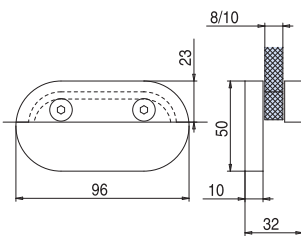

xla80

M14

- Battuta per porta singola con attacco a sopra luce e fisso laterale.
- Stop fixed on overpanel and side panel left / right.
- Anschlag fest am Oberlicht und Seitenteil links / rechts.

NS

▶ G.53

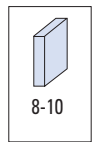
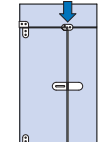
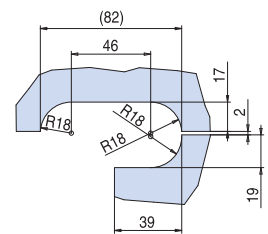
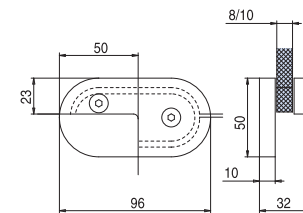

xla80-1



M9

- Supporto vetro fisso.
- Wall connector.
- Wandhalter.

NS

€ ► G.51

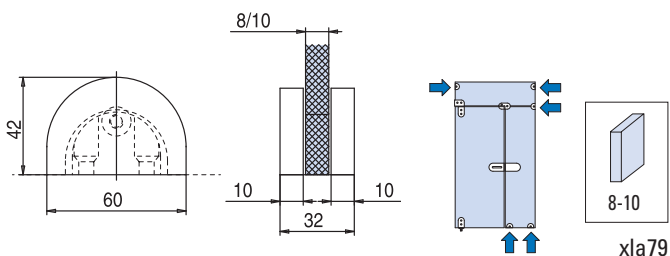

xla79



M15

- Morsetto per aggancio due vetri.
- Connector glass-glass.
- Verbindungsbeschlag Glas-Glas.

NS

€ ► G.54

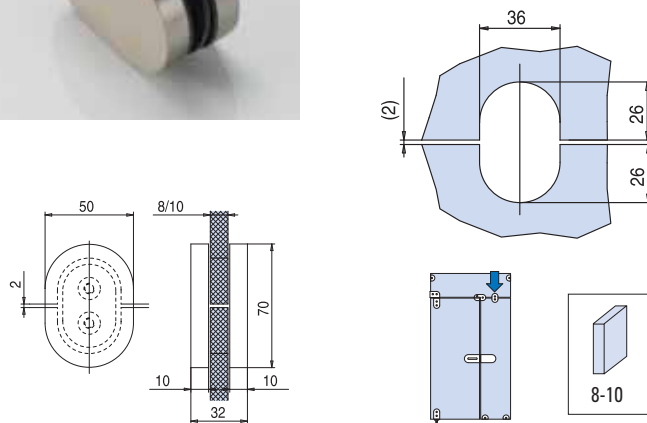

xla79-1



M16-L

- Cerniera regolabile con attacco a sopraluce e fisso laterale sinistra.
- For overpanel and side panel left.
- Winkeloberlichtbeschlag. Links.

NS

€ ► G.59

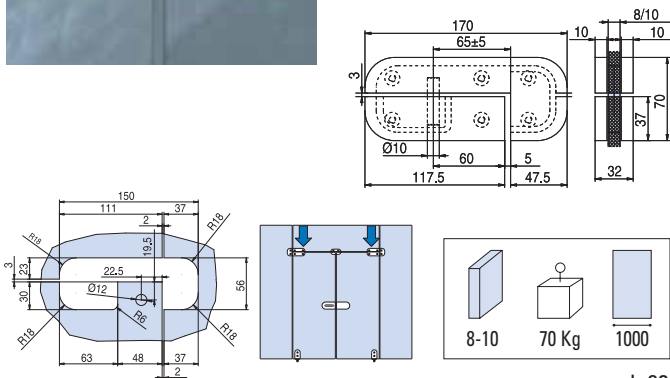

xla82



M16-R

- Cerniera regolabile con attacco a sopraluce e fisso laterale destra.
- For overpanel and side panel right.
- Winkeloberlichtbeschlag. Rechts.

NS

€ ► G.58

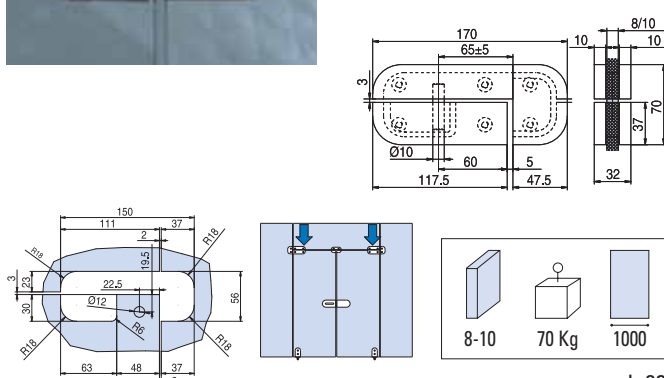

xla82



M1-SET

- Set Cerniere superiore e sopraluce con perno.
- Overpanel/top pivot set.
- Set Oberes / Oberlicht Pendeltürbänder.

NS

€ ► G.60

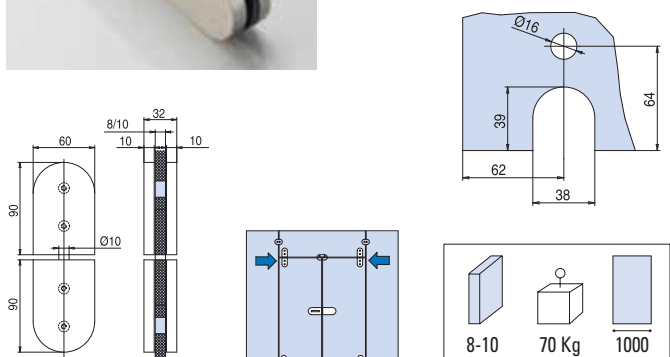

xla82-1



XT-83 B

- Perno a pavimento con quadro tedesco ovale.
- Floor pivot with German profile spindle.
- Bodenbuchse mit flachkonischer Achse.

€ ► G.50

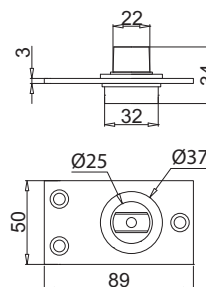

gpe012



CERNIERE SERIE X **HINGES SERIE X / BÄNDER SERIE X**

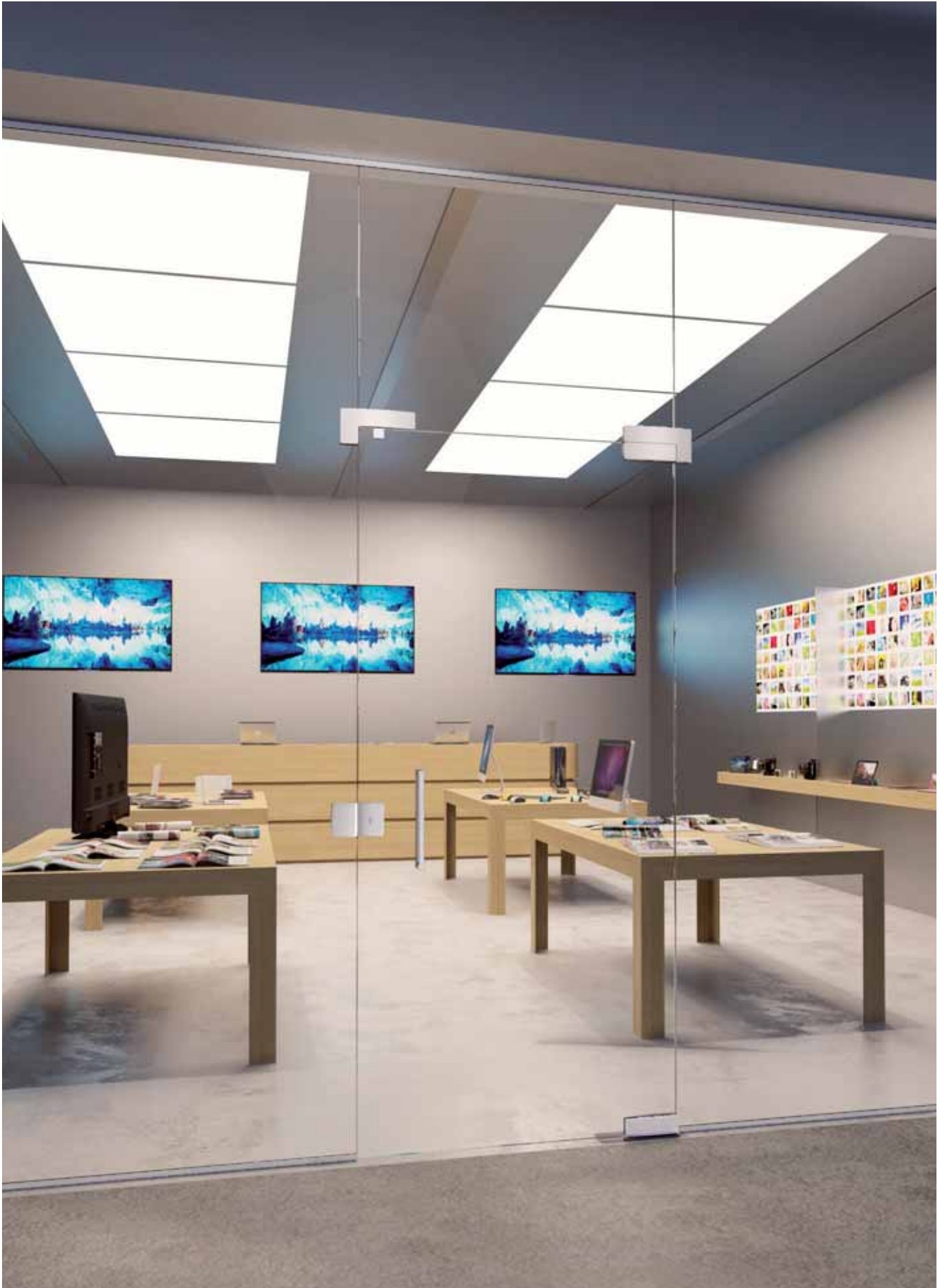

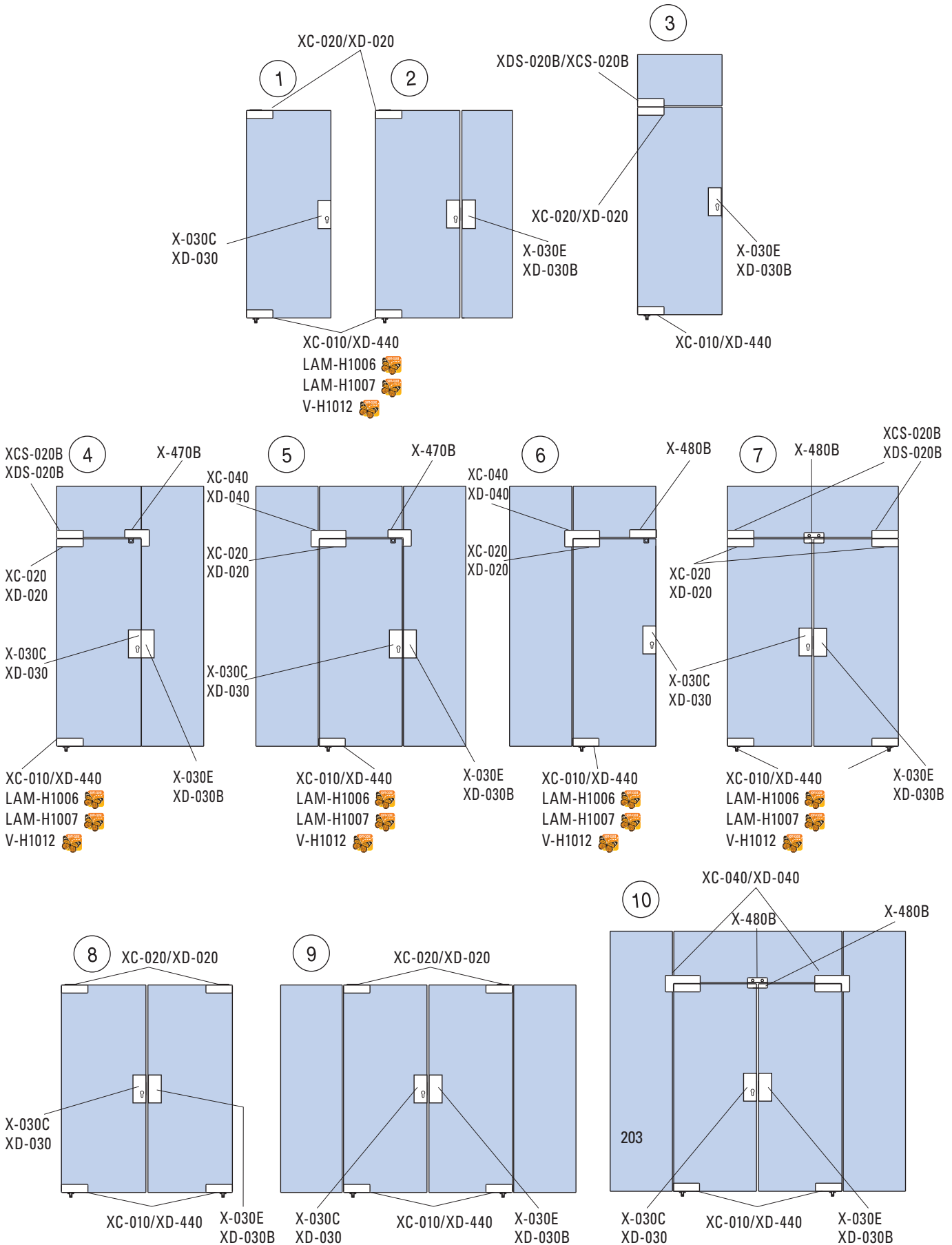
TIPOLOGIA DI APPLICAZIONE / APPLICATION TYPOLOGIES / KOMPOSITIONSMÖGLICHKEITEN DES SYSTEM



XC-010

€ G.61

- Cerniera inferiore per pompa Tedesca quadro ovale.
 - Bottom pivot hinge for german door closer.
 - Unteres Pendeltürband für Bodentürschließer mit flachkonischer Achse.
- IX - IL

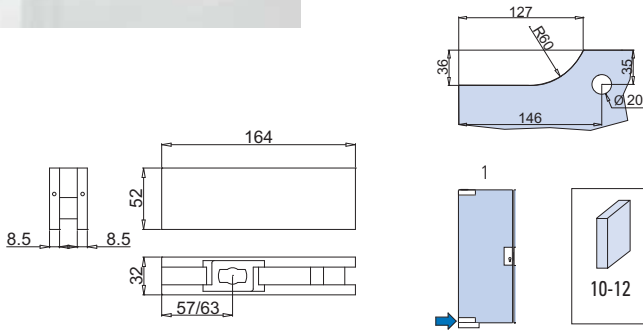

gpe001



XC-020

€ G.62

- Cerniera superiore registrabile.
 - Top patch with regulation.
 - Oberer Eckbeschlag mit verstellbarem Lager.
- IX - IL

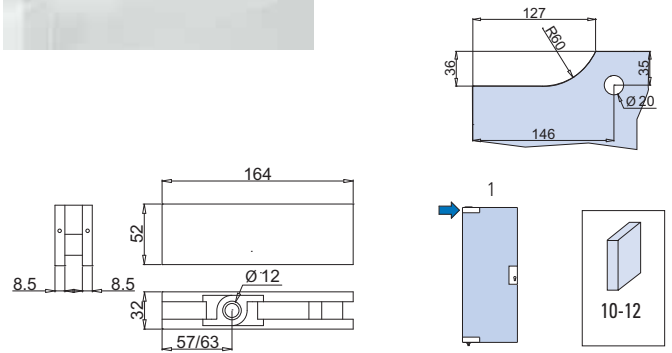

gpe001



XCS-020 B

€ G.63

- Cerniera con attacco sopraulce/muro perno mm 12.
 - Overpanel patch with pivot 12 mm and wall plate.
 - Oberlichtbeschlag mit Zapfen 12 mm und Befestigungslasche.
- IX - IL

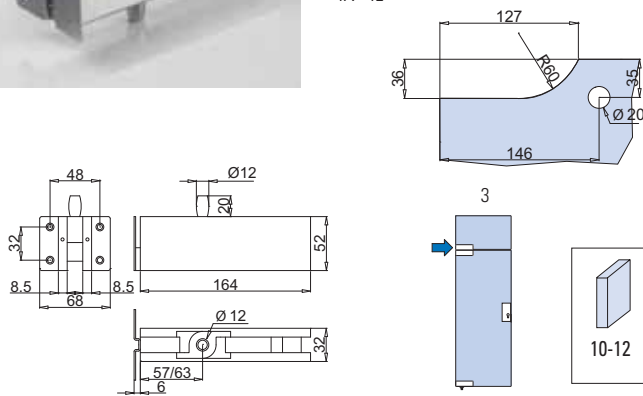

gpe001



XCS-020

€ G.64

- Cerniera con attacco sopraulce mm 12.
 - Overpanel patch 12 mm with pivot.
 - Oberlichtbeschlag 12 mm mit Zapfen.
- IX - IL

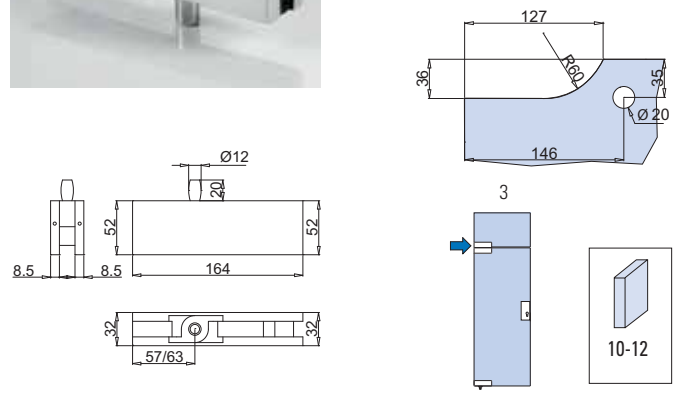

gpe002



XC-040

€ G.65

- Cerniera attacco sopraulce vetro fisso perno mm 12.
 - Patch for overpanel and side panel with pivot 12 mm.
 - Winkeloberlichtbeschlag mit Zapfen 12 mm.
- IX - IL

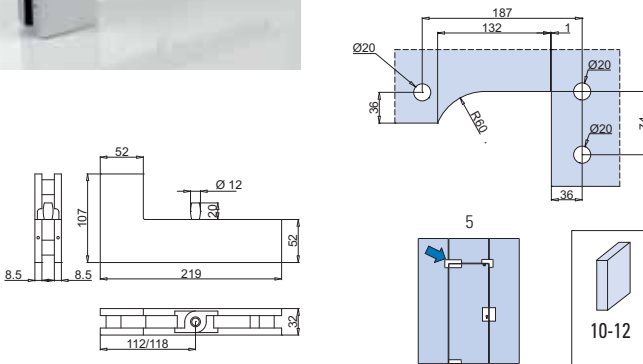

gpe002



X-060-B

€ G.66

- Morsetto singolo muro-vetro per vetrate fisse, 53x53 mm.
 - Wall connector 53x53 mm
 - Wandhalter 53x53 mm
- IX - IL

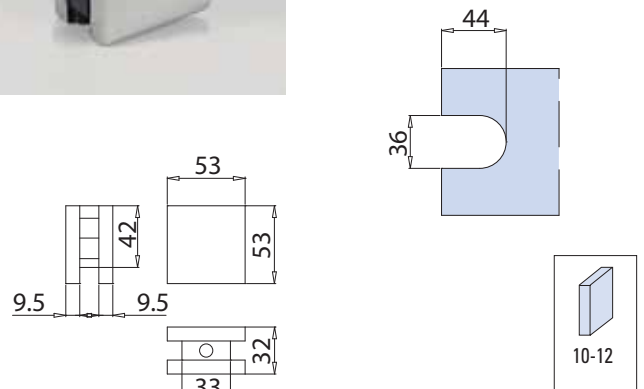

gpe002

X-080

- Morsetto singolo muro-vetro per vetrate fisse, 70x53 mm.
- Wall connector 70x53 mm.
- Wandhalter 70x53 mm.

IX - IL

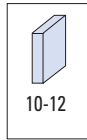
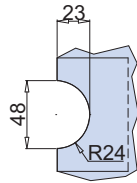
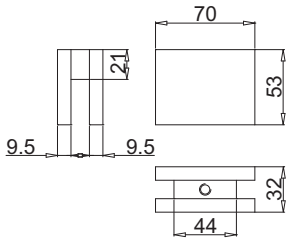

10-12

gpe003

X-440

- Morsetto per aggancio 4 vetri.
- Connector 4 glasses.
- Verbindungsbeschlag 4 Gläser.

IX - IL

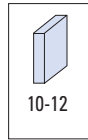
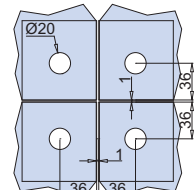
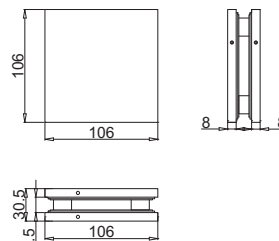

10-12

gpe003

X-470B

- Cerniera con attacco sopra-luce-vetro fisso con battuta.
- Patch for overpanel and side panel with stop.
- Winkeloberlicht Beschlag mit Anschlag.

IX - IL

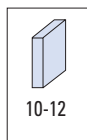
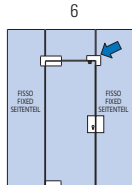
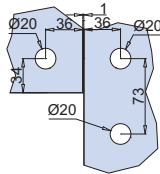
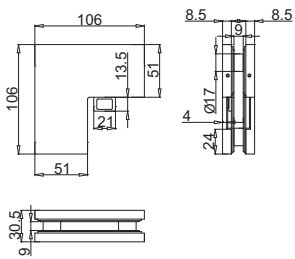

10-12

gpe003

X-480B

- Morsetto per aggancio 2 vetri sopra-porta compreso di accessorio battuta.
- Connector 2 glasses with stop.
- Verbindungsbeschlag 2 Gläser mit Anschlag.

IX - IL

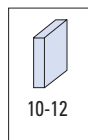
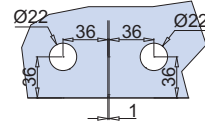
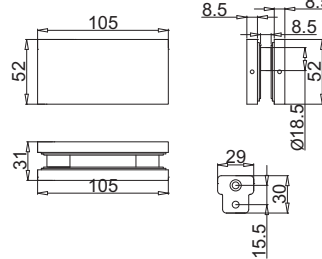

10-12

gpe004

X-400

- Cerniera superiore doppia attacco sopra-luce registrabile, perno 15 mm.
- Double patch for overpanel with pivots 15 mm.
- DoppelOberlichtbeschlag mit Zapfen 15 mm.

IX - IL

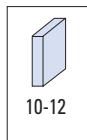
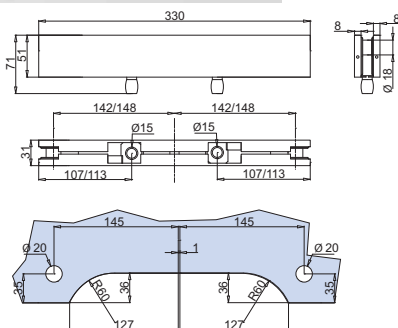

10-12

gpe004

X-400B

- Doppia contro serratura con attacco sopra-luce.
- Double overpanel strike patch fitting.
- Doppeloberlichtgegenkasten.

IX - IL

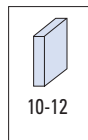
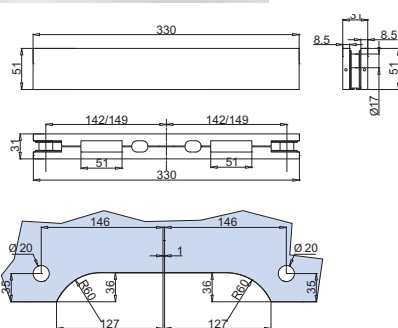

10-12

gpe004



X-420

€ G.73

- Supporto per due porte in linea con elemento per fissare vetro fisso perno 15 mm.
- Double patch for overpanel side panel with pivots 15 mm and fin fitting inside.
- Doppelter Obererlichtbeschlag mit einseitiger Aussteifunglasche. IX - IL

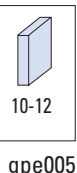
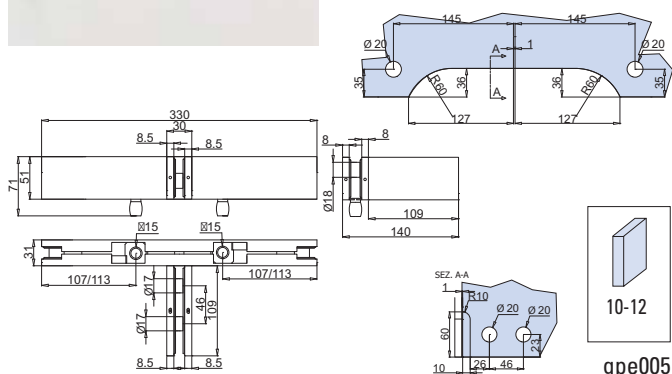

gpe005



X-460

€ G.74

- Supporto destro per una porta perno 15 mm e vetro fisso.
- Right patch for overpanel, side panel with fin fitting inside.
- Obererlichtbeschlag rechts mit einseitiger Aussteifunglasche. IX - IL

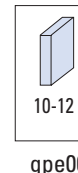
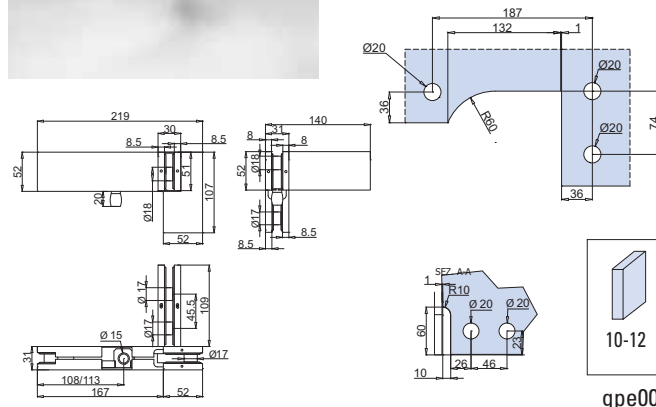

gpe005



X-450

€ G.75

- Supporto sinistro per una porta perno 15 mm e vetro fisso.
- Left patch for overpanel, side panel with fin fitting inside.
- Obererlichtbeschlag links mit einseitiger Aussteifunglasche. IX - IL

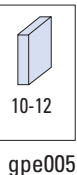
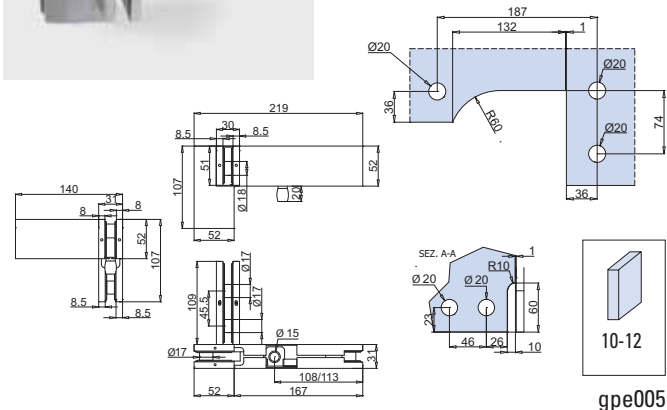

gpe005



X-020

€ G.76

- Cerniera superiore registrabile da accoppiare con X-420, X-450, X-460.
- Top patch with regulation. Matching with X-420, X-450, X-460.
- Oberer Eckbeschlag mit verstellbarem Lager. Montierbar mit X-420, X-450, X-460. IX - IL

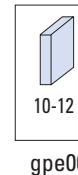
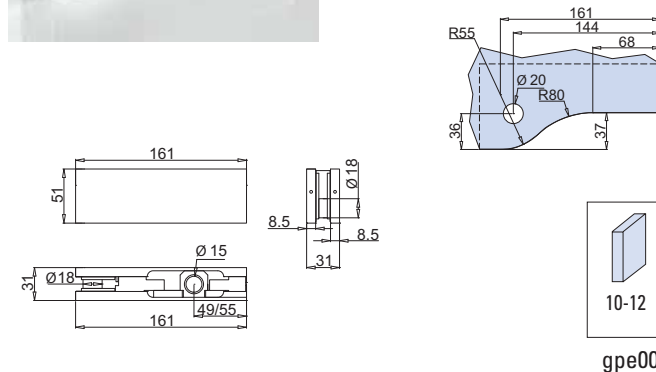

gpe006



XC-410

€ G.77

- Cerniera raccordo più vetri fissi.
- Connector with fin fitting.
- Verbindungsbeschlag mit einseitiger Aussteifunglasche. IX - IL

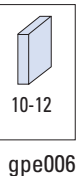
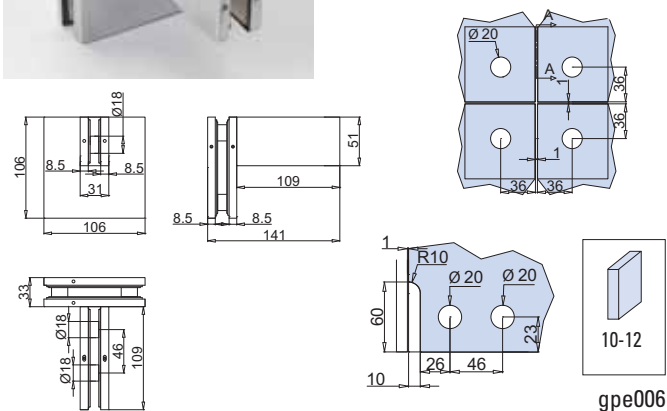

gpe006



X-030 C

€ G.78

- Serratura con scrocco rettangolare.
- Lock.
- Schloss. IX - IL

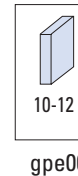
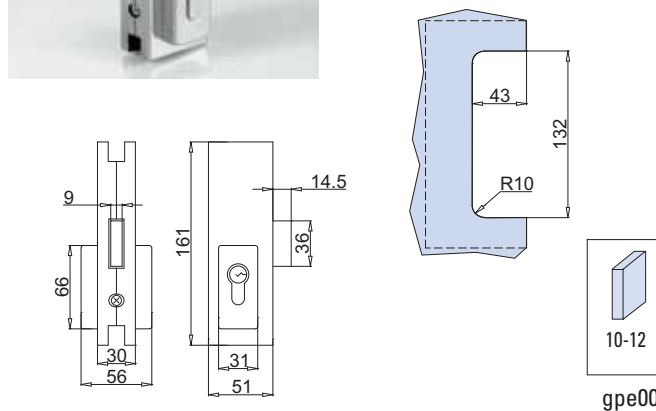

gpe006



X-030 E

€ ▶ G.79

- Controserratura per X-030C.
 - Strike box for x-030 C.
 - Gegenkasten für X-030C.
- IX - IL

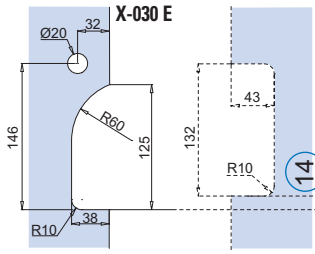
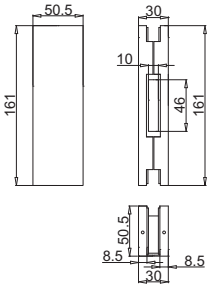

- X-030 C**
- Serratura
 - Lock
 - Schloss

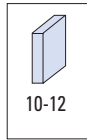

gpe007



X-040 B

€ ▶ G.80

- Controserratura con attacco sopra-ruce-vetro fisso per serratura ad angolo X-030C.
 - Corner overpanel strike box for corner lock X-030C.
 - Winkeloberlichtgegenkasten für Eckschloss X-030C.
- IX - IL

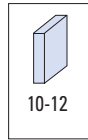
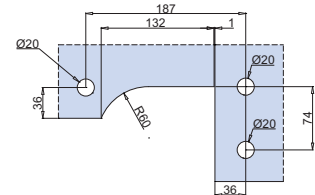
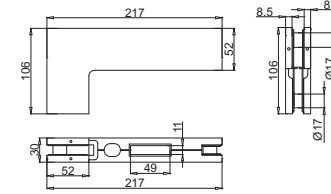

gpe007



X-133

€ ▶ G.81

- Serratura con perno compreso di pozzetto a pavimento.
 - Corner lock with floor socket.
 - Eckschloss mit Bodenbuchse.
- IX - IL

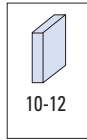
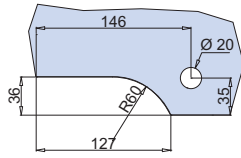
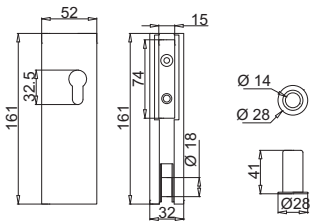

gpe007



X-134

€ ▶ G.82

- Controserratura per X-133.
 - Strike box for X-133.
 - Gegenkasten für X-133.
- IX - IL

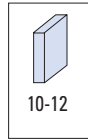
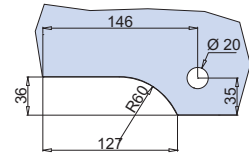
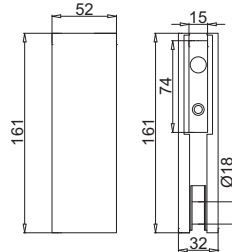

gpe008



X-090

€ ▶ G.84

- Chiavistello.
 - Locking Bolt.
 - Feststellriegel.
- IX - IL

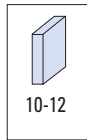
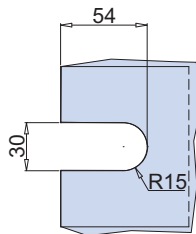
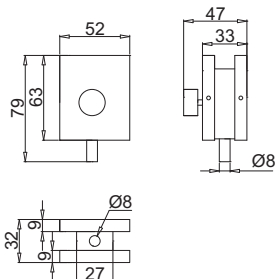

gpe008



X-090B

€ ▶ G.83

- Incontro a vetro per chiavistello X-090.
 - Strike box for locking bolt X-090.
 - Gegenkasten für Feststellriegel X-090.
- IX - IL

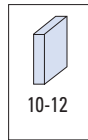
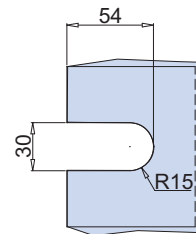
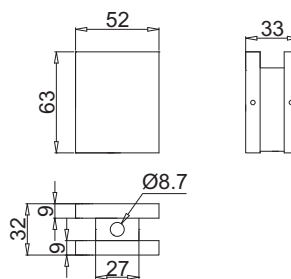

gpe008



X-317

€ ▶ G.85

- Chiavistello compreso di incontro, senza fori nel vetro.
 - Lock with rounded dead bolt and strike box without glass preparation.
 - Mittelschloss mit Gegenkasten ohne Glasbearbeitung.
- IX - IL

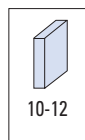
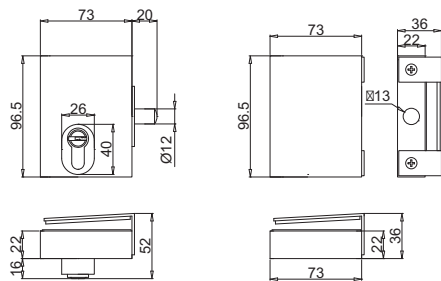

10-12

gpe009



XT-83B

€ ▶ G.86

- Perno a pavimento con quadro tedesco ovale.
- Floor pivot with German profile spindle.
- Bodenbuchse mit flachkonischer Achse.

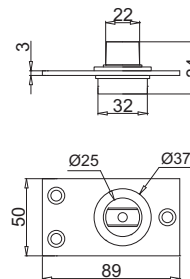

gpe009



XP-020

€ ▶ G.87

- Perno superiore 12 mm.
- Top pin 12 mm.
- Oberer Zapfen 12 mm.

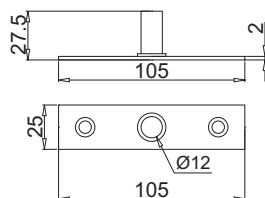

gpe009

CERNIERE SERIE X MINI

HINGES SERIE X MINI / BÄNDER SERIE X MINI



XD-020

- Cerniera superiore registrabile.
 - Top patch adjustable.
 - Oberer Eckbeschlag mit verstellbarem Lager.
- AN - IL

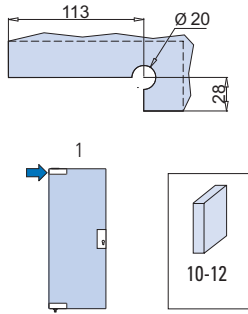
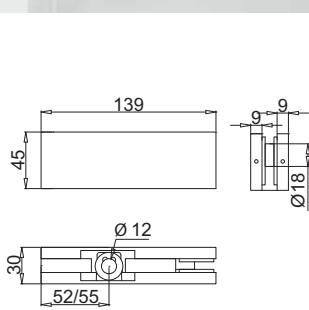

gpe010



XD-440

- Cerniera inferiore per pompa Tedesca quadro ovale.
 - Bottom pivot hinge for german door closer.
 - Unteres Pendeltürband für Bodentürschließer mit flachkonischer Achse.
- AN - IL

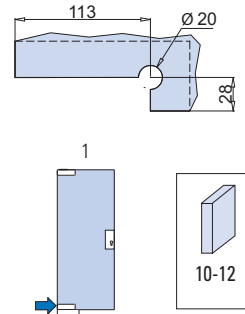
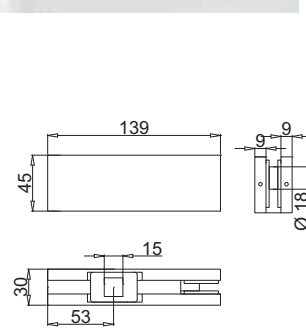

gpe010



XDS-020

- Cerniera con attacco sopra luce, perno 12 mm.
 - Overpanel patch with pivot 12 mm.
 - Oberer Lichtbeschlag mit Zapfen 12 mm.
- AN - IL

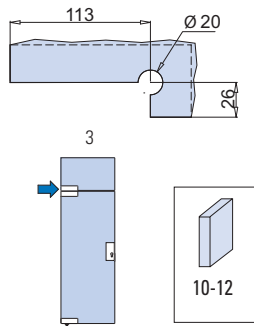
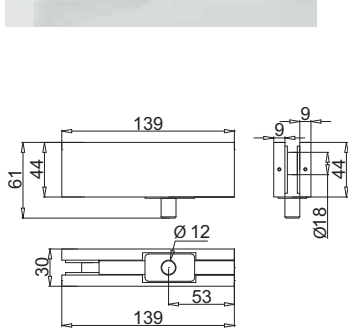

gpe010



XDS-020B

- Cerniera con attacco sopra luce-muro, perno 12 mm.
 - Overpanel patch with pivot 12mm and wallplate.
 - Oberer Lichtbeschlag mit Zapfen 12mm und Befestigungslasche.
- AN - IL

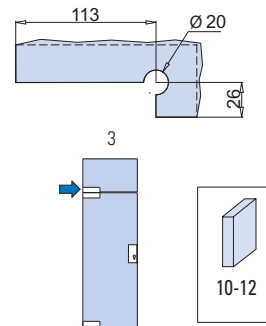
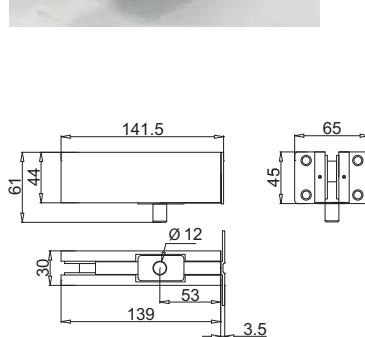

gpe011



XD-040

- Cerniera attacco per sopra luce vetro fisso perno 12 mm.
 - Patch for overpanel and side panel with pivot 12 mm.
 - Winkeloberlichtbeschlag mit Zapfen 12 mm.
- AN - IL

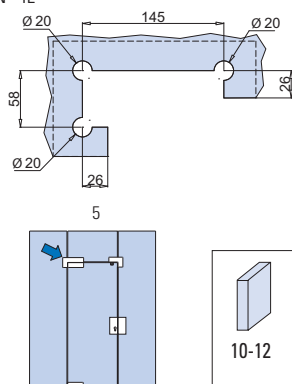
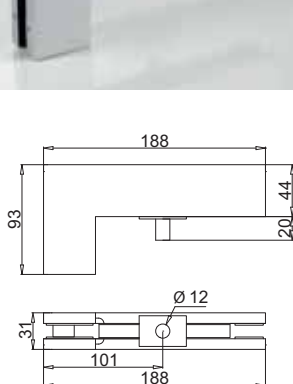

gpe011



XD-030

- Serratura con chiavistello tondo.
 - Rounded dead bolt.
 - Mittelschloss.
- AN - IL

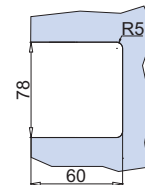
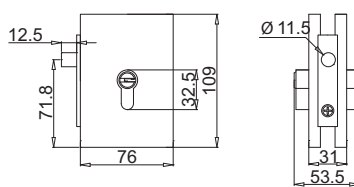

gpe011



XD-030 B

€ ▶ G.94

- Controserratura per chiavistello tondo XD-030.
- Strike box for XD-030.
- Gegenkasten für Schloss XD-03 AN - IL

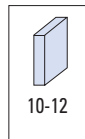
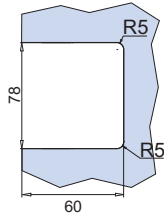
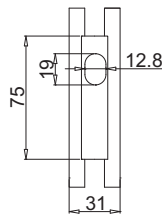
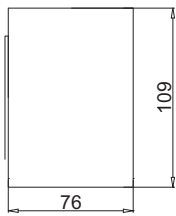

gpe012



XT-83 B

€ ▶ G.95

- Perno a pavimento con quadro tedesco ovale.
- Floor pivot with German profile spindle.
- Bodenbuchse mit flachkonischer Achse.

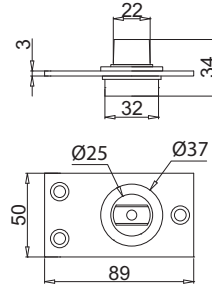

gpe012



XP-020

€ ▶ G.96

- Perno superiore 12 mm.
- Top pin 12 mm.
- Oberer Zapfen 12 mm.

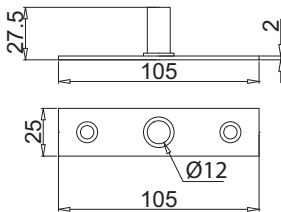

gpe012



ANTIK

MANIGLIE, MANIGLIONI E POMOLI / DOORHANDLES, PULLHANDLES AND KNOBS / TÜRGRIFFE, STOSSGRIFFE UND KNÖPFE



LIBRA V-720 ANTIK

- Serratura, maniglie, cilindri e contropiastre da ordinare a parte
- Lock, cylinders and strike plates not included, to order separately
- Schloss, Zylinder und Schließbleche nicht enthalten, separat zu bestellen

NB - AI - BT

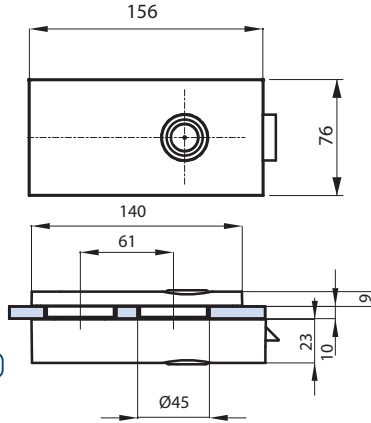
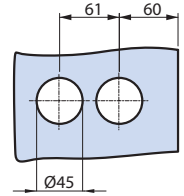
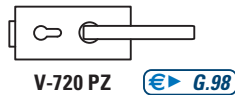
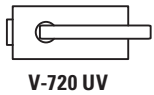
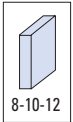
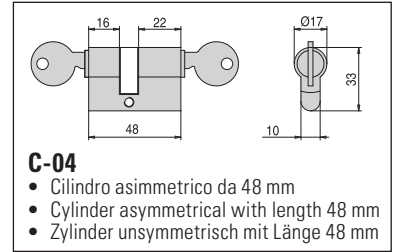



xme047

SLIM V-509 ANTIK

- Cerniere
- Hinges
- Bänder

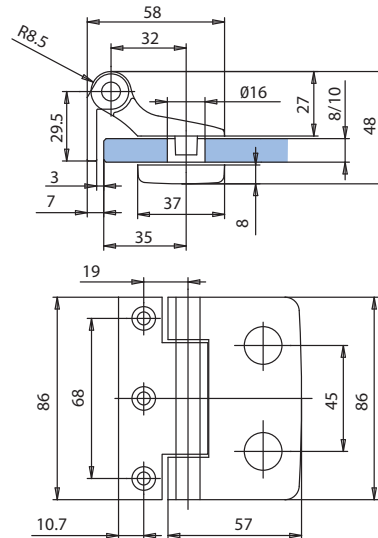
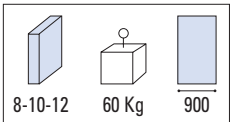
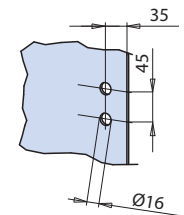
NB - AI - BT





xla46

V-402 ANTIK

- Cerniere
- Hinges
- Bänder

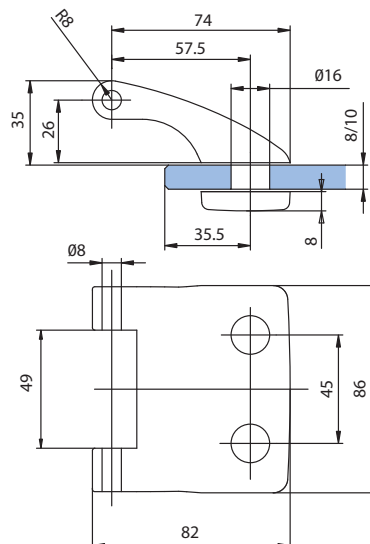
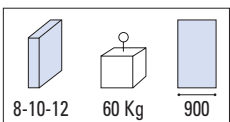
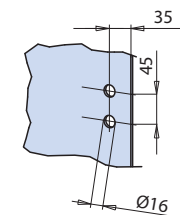
NB - AI - BT

xla34

NB
 Bronzo naturale
 Natural Bronze
 Natur Bronze

AI
 Ferro antico
 Ancient iron
 Antik-Eisen

BT
 Britannium
 Britannium
 Britannium

NB
 Essendo prodotti fusi con tecniche artigianali, le misure esterne sono indicative
 Products are fused and worked with artisan techniques, so the dimensions are approximate
 Die Produkte werden nach den Handwerkstraditionen geschmolzen und bearbeitet, somit sind die Maße ungefähr



V-110

- Coppia pomoli per porte in vetro
- Pair of knobs for glass door
- Paar Türknöpfe

NB - AI - BT

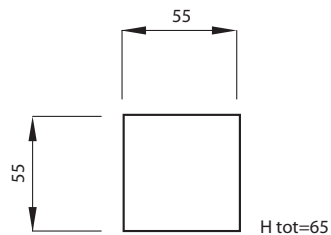

€▶G.118



V-1742

- Paio maniglie per serrature vetro (serrature e rosette escluse)
- Pair handles for glasslocks (lock and rosette not included)
- Paar Türgriffe für Glastürschlösser (Schloss und Rosette nicht enthalten)

NB - AI - BT

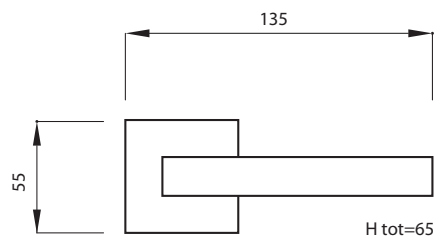

€▶G.119



16.41.03/260.315

- Maniglione
- Pullhandle
- Stossgriff

NB - AI - BT

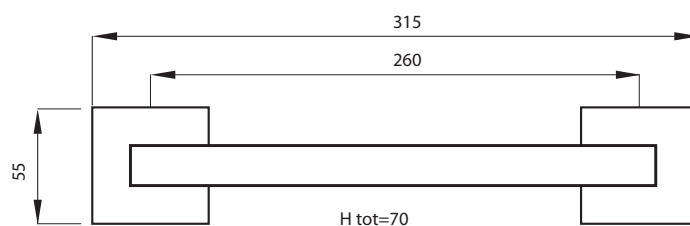

€▶G.117



ANTIK

PORTE ESTERNE, INTERNE A BILICO / PATCH FITTINGS / GANZGLASANLAGEN



TIPOLOGIA DI APPLICAZIONE / APPLICATION TYPOLOGIES / KOMPOSITIONSMÖGLICHKEITEN DES SYSTEM

- | | | | |
|----------|----------------------------|----------|--|
| D | • Porta
• Door
• Tür | F | • Parte fissa
• Fixed panel
• Seitenteil |
|----------|----------------------------|----------|--|

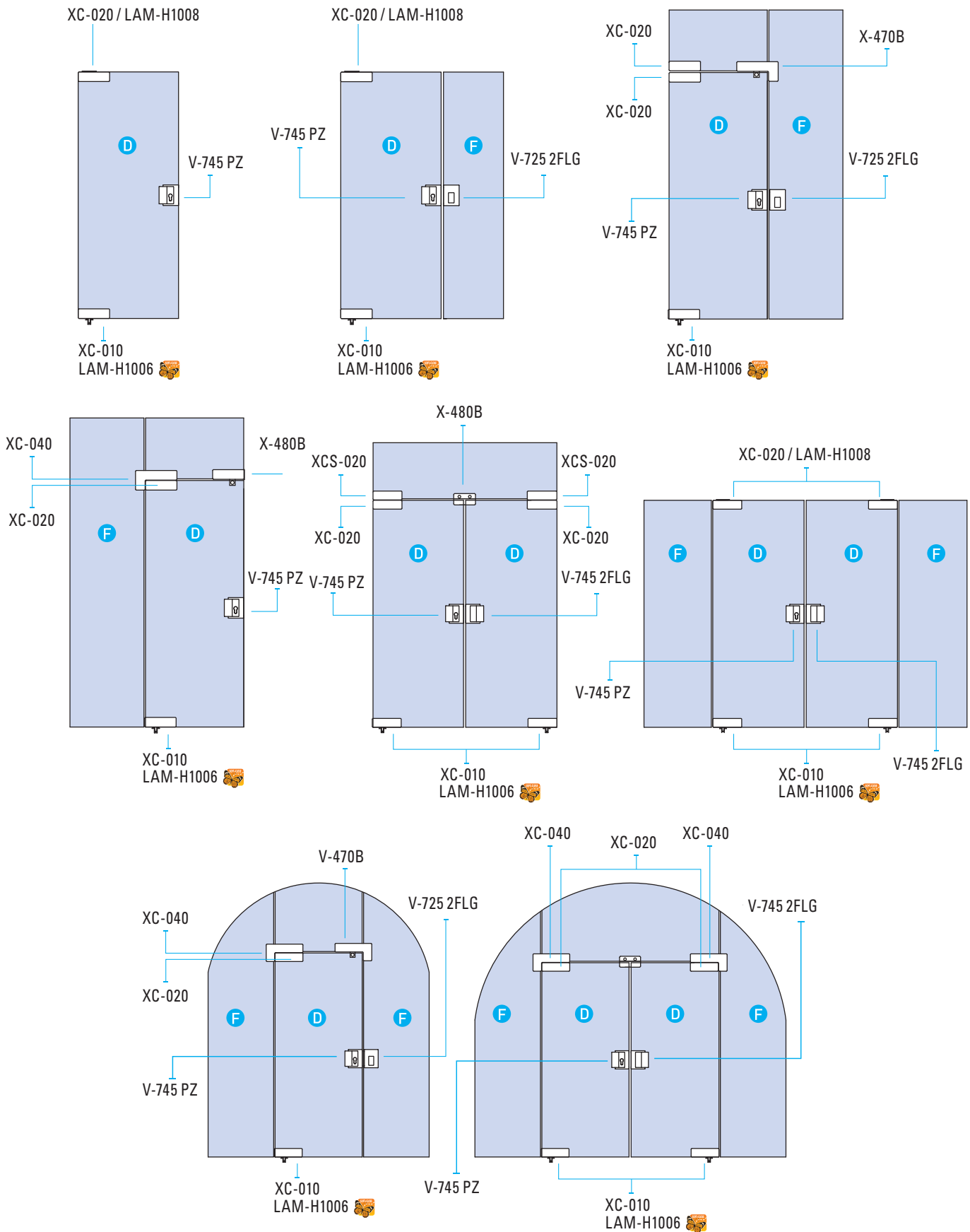

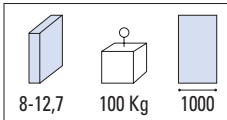

LAM-H1006 ANTIK

- Cerniera inferiore oleodinamica con chiudiporta integrato, stop a 0° +90° -90°.
- Hydraulic bottom hinge with integrated door closer stop at 0° +90° -90°.
- Unteres Hydraulikband mit Einstellung der Türschließgeschwindigkeit Stop zu 0°, +90°, -90°.

NB - AI - BT

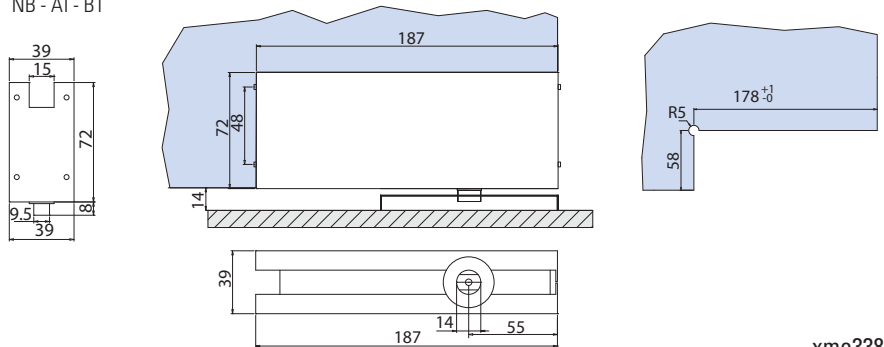

€▶G.107

xme338

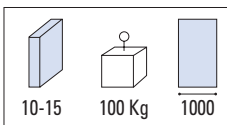

LAM-H1008 ANTIK

- Cerniera superiore registrabile con copertine di misure come LAM-H1006.
- Top patch adjustable with cover plate's size same as LAM-H1006.
- Oberer Eckbeschlag, Abdeckungen wie LAM-H1006 mit verstellbarem Lager.

NB - AI - BT

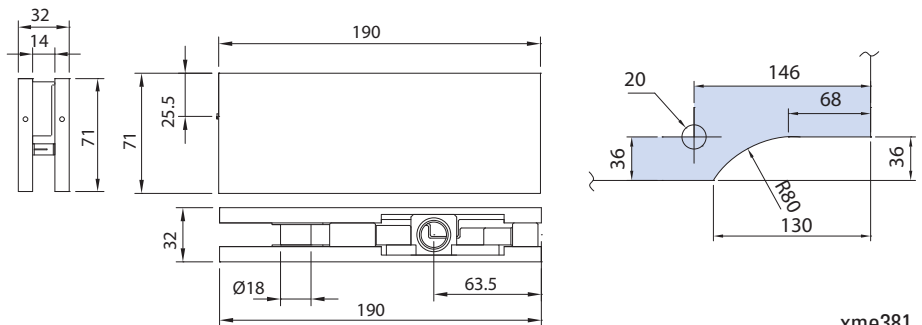

€▶G.108

xme381

REGOLA LA POSIZIONE DELLA PORTA
ADJUST THE DOOR POSITION
PASSEN SIE DIE TÜRPOSITION AN

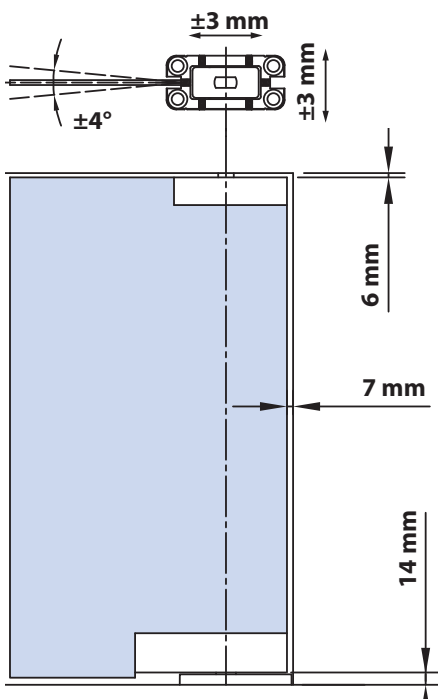

REGOLAZIONE VALVOLA VELOCITÀ
SPEED ADJUSTING VALVE
REGELVENTIL

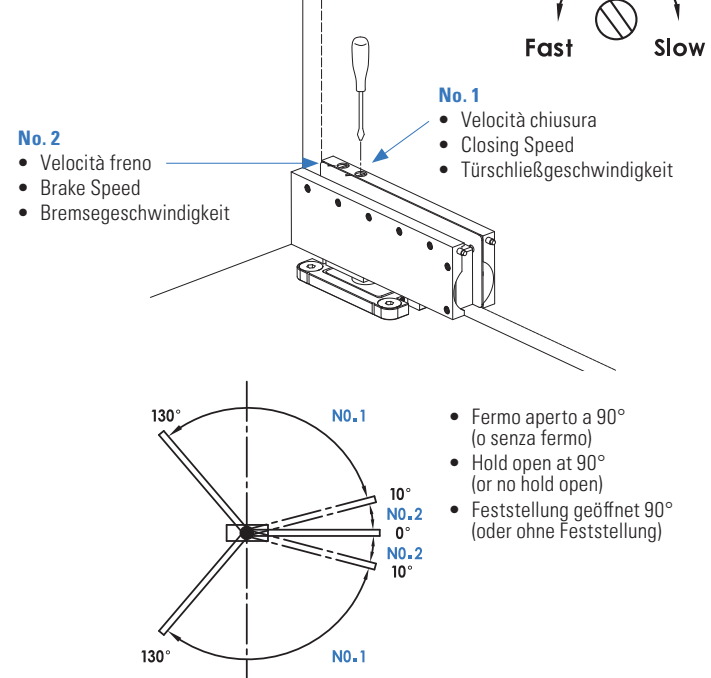

NB Bronzo naturale Natural Bronze Natur Bronze	AI Ferro antico Ancient iron Antik-Eisen	BT Britannium Britannium Britannium
--	--	---

NB
Essendo prodotti fusi con tecniche artigianali, le misure esterne sono indicative
Products are fused and worked with artisan techniques, so the dimensions are approximate
Die Produkte werden nach den Handwerkstraditionen geschmolzen und bearbeitet, somit sind die Maße ungefähr

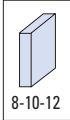

8-10-12

V-745 PZ ANTIK

- Serrature con chiavistello tondo, per vetri con spessori 13,5 - 17,5 - 21,5. Impugnatura leva incorporata. Cilindri e contropiastre da ordinare a parte.
- Locks Elegant with rounded dead bolt, for glass thickness 13,5 - 17,5 - 21,5. Lever handle incorporated. Cylinders and strike plates not included, to order separately.
- Elegant Mittelschloss mit Bolzen, für Glasdicke 13,5 - 17,5 - 21,5. Griff angebaut. Zylinder und Schließbleche nicht enthalten, separat zu bestellen.

NB - Al - BT

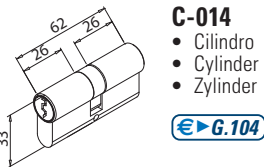
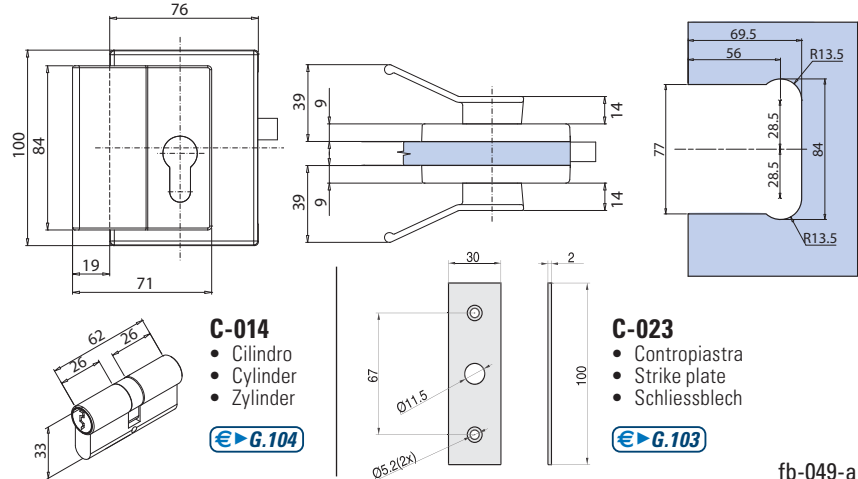

fb-049-a

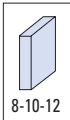

8-10-12

V-745 2FLG ANTIK

- Controserratura
- Strike box
- Gegenkasten

NB - Al - BT

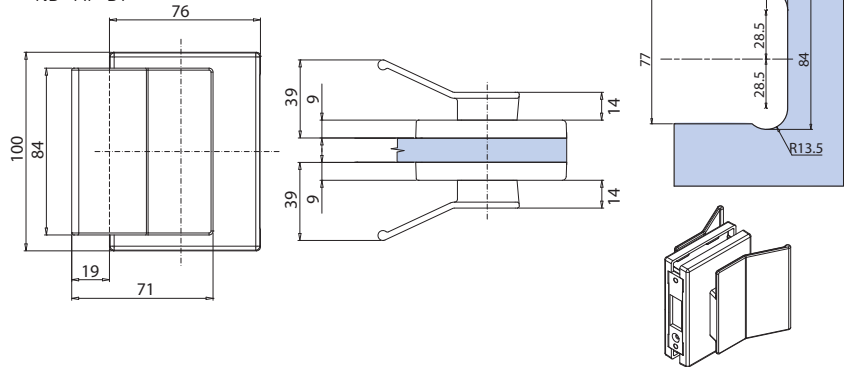

fb-049-a

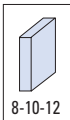

8-10-12

V-725 2FLG ANTIK

- Controserratura
- Strike box
- Gegenkasten

NB - Al - BT

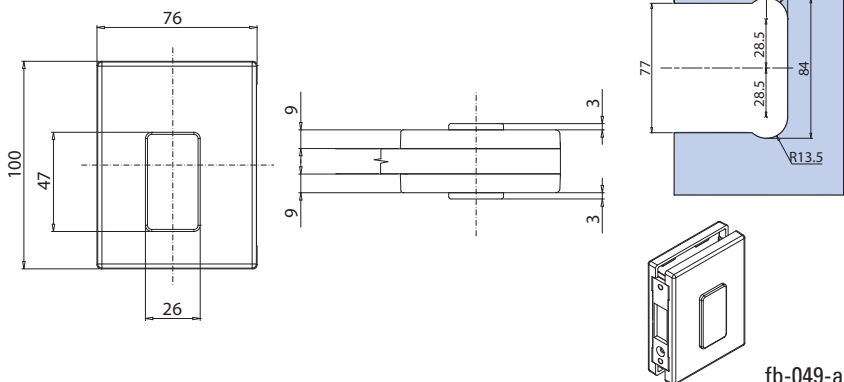

fb-049-a

NB
 Bronzo naturale
 Natural Bronze
 Natur Bronze

Al
 Ferro antico
 Ancient iron
 Antik-Eisen

BT
 Britannium
 Britannium
 Britannium

NB
 Essendo prodotti fusi con tecniche artigianali, le misure esterne sono indicative
 Products are fused and worked with artisan techniques, so the dimensions are approximate
 Die Produkte werden nach den Handwerkstraditionen geschmolzen und bearbeitet, somit sind die Maße ungefähr

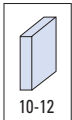

XC-020 ANTIK

- Cerniera superiore registrabile.
- Top patch with regulation.
- Oberer Eckbeschlag mit verstellbarem Lager.

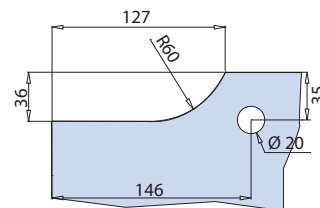
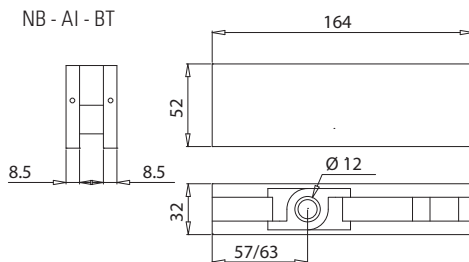

€ G.109

gpe001

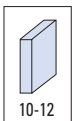

XC-010 ANTIK

- Cerniera inferiore per pompa Tedesca quadro ovale.
- Bottom pivot hinge for german door closer.
- Unteres Pendeltürband für Bodentürschließer mit flachkonischer Achse.

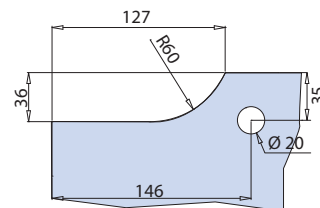
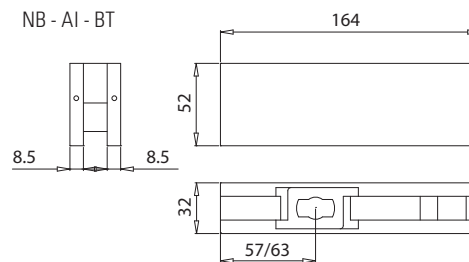

€ G.110

gpe001

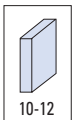

XCS-020 ANTIK

- Cerniera con attacco sopra luce mm 12.
- Overpanel patch 12 mm with pivot.
- Oberlichtbeschlag 12 mm mit Zapfen.

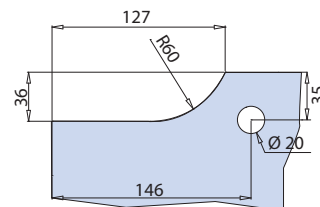
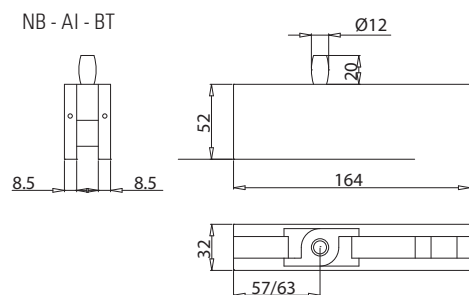

€ G.111

gpe002

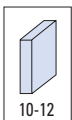

XC-040 ANTIK

- Cerniera attacco sopra luce vetro fisso perno mm 12.
- Patch for overpanel and side panel with pivot 12 mm.
- Winkeloberlichtbeschlag mit Zapfen 12 mm.

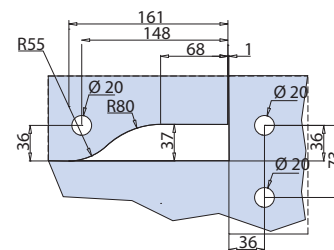
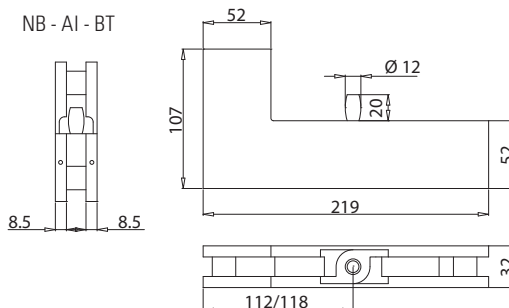

€ G.112

gpe002

NB
Bronzo naturale
Natural Bronze
Natur Bronze

AI
Ferro antico
Ancient iron
Antik-Eisen

BT
Britannium
Britannium
Britannium

NB
Essendo prodotti fusi con tecniche artigianali, le misure esterne sono indicative
Products are fused and worked with artisan techniques, so the dimensions are approximate
Die Produkte werden nach den Handwerkstraditionen geschmolzen und bearbeitet, somit sind die Maße ungefähr

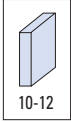

X-470B ANTIK

- Cerniera con attacco sopra-luce-vello fisso con battuta.
- Patch for overpanel and side panel with stop.
- Winkeloberlicht Beschlag mit Anschlag.

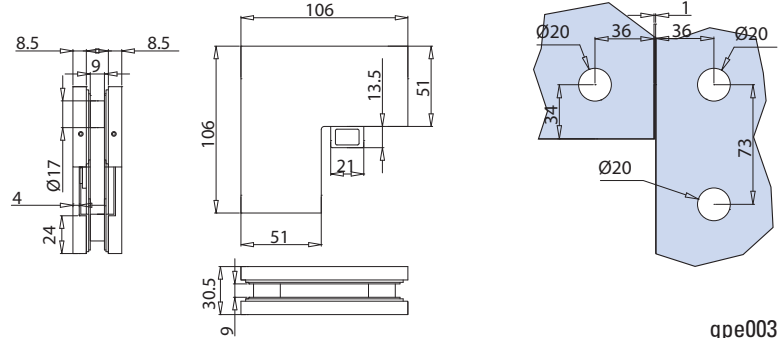
NB - AI - BT

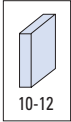

gpe003



X-480B ANTIK

- Morsetto per aggancio 2 vetri sopraporta compreso di accessorio battuta.
- Connector 2 glasses with stop.
- Verbindungsbeschlag 2 Gläser mit Anschlag.

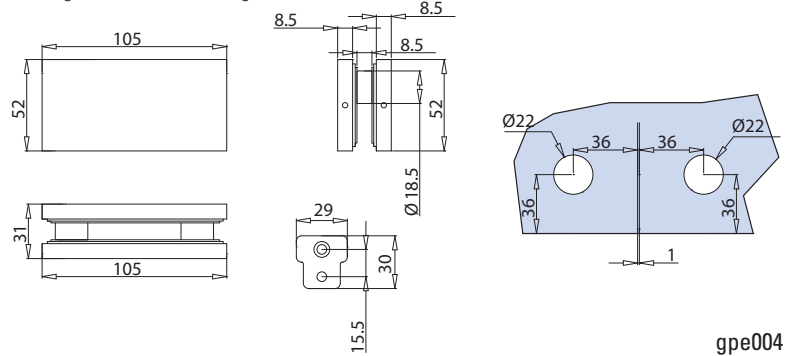
IX - IL

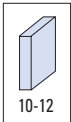

gpe004



X-060-B ANTIK

- Morsetto singolo muro-vello per vetrate fisse, 53x53 mm.
- Wall connector 53x53 mm
- Wandhalter 53x53 mm

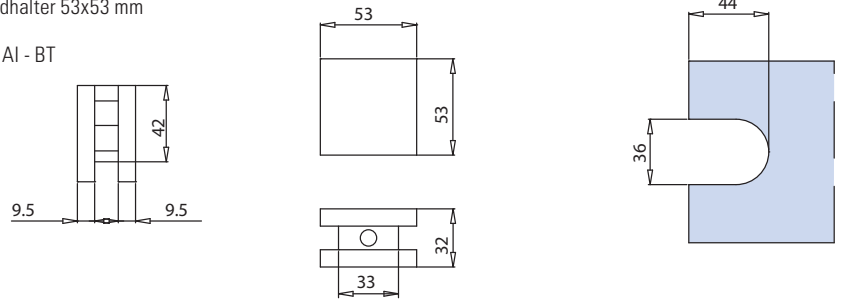
NB - AI - BT

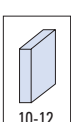

gpe002

X-080 ANTIK

- Morsetto singolo muro-vello per vetrate fisse, 70x53 mm.
- Wall connector 70x53 mm.
- Wandhalter 70x53 mm.

NB - AI - BT

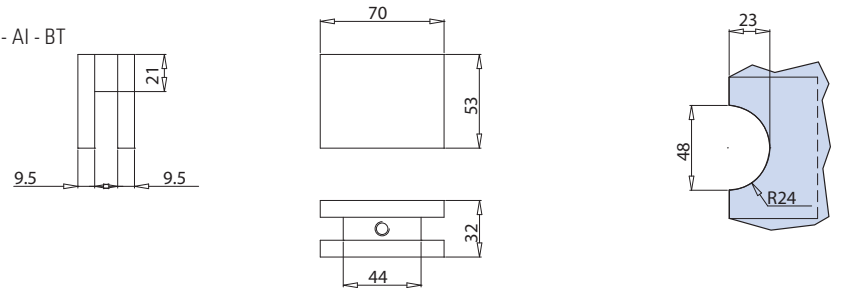

gpe003

NB
 Bronzo naturale
 Natural Bronze
 Natur Bronze

AI
 Ferro antico
 Ancient iron
 Antik-Eisen

BT
 Britannium
 Britannium
 Britannium

NB
 Essendo prodotti fusi con tecniche artigianali, le misure esterne sono indicative
 Products are fused and worked with artisan techniques, so the dimensions are approximate
 Die Produkte werden nach den Handwerkstraditionen geschmolzen und bearbeitet, somit sind die Maße ungefähr

CHIUDI PORTA A PAVIMENTO **DOOR CLOSER / BODENTÜRSCHLIESSER**



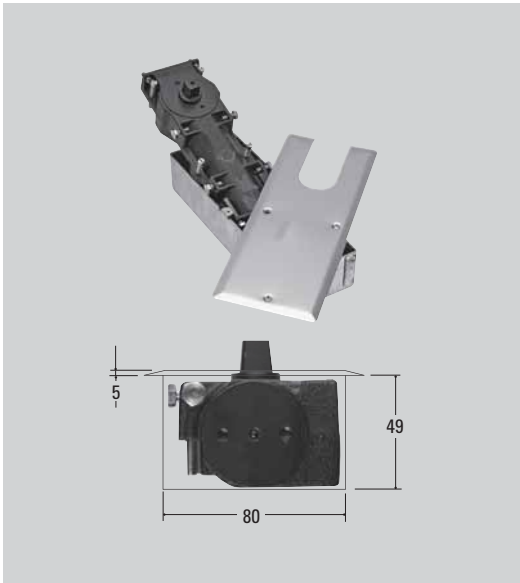

FV-S4003

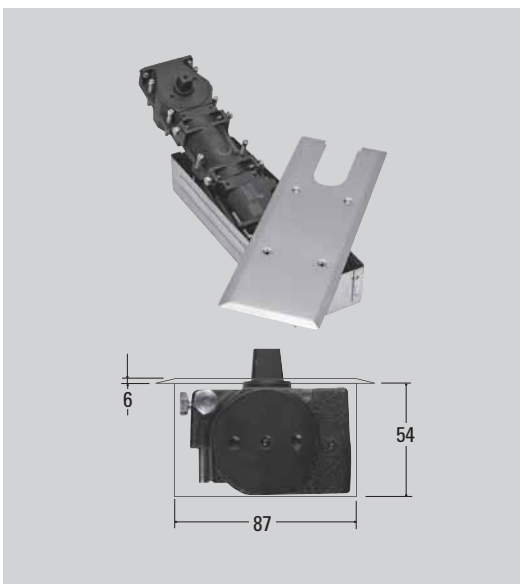
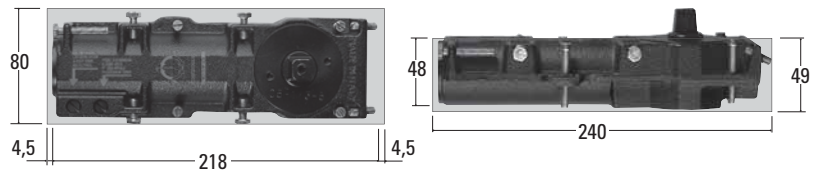
- Chiudiporta a pavimento con perno intercambiabile. Completo di perno italiano, scatola a cementare zincata e piastra in acciaio inox satinato AISI 304. Fermo a 90° - FORZA EN: 3 - Scatola 240x80x49 - Larghezza. ANTA: mm. 900 - 1050.
- Floor spring with interchangeable pivot, Standard with italian square pivot, cover plate in satin stainless steel AISI 304. Hold open at 90° - Force 3 - Cement box 240 x 80 x 49 - Door width range: mm. 900 - 1050.
- Bodentürschließer mit anstauschbaresteckachsen. Standard mit Italianischen Vierkant, einschließlich Zementkasten 240 x 80 x 49 und Deckplatte aus Edelstahl matt AISI 304 - Feststellung 90° - Türbreite mm 900 - 1050.

FV-S5003

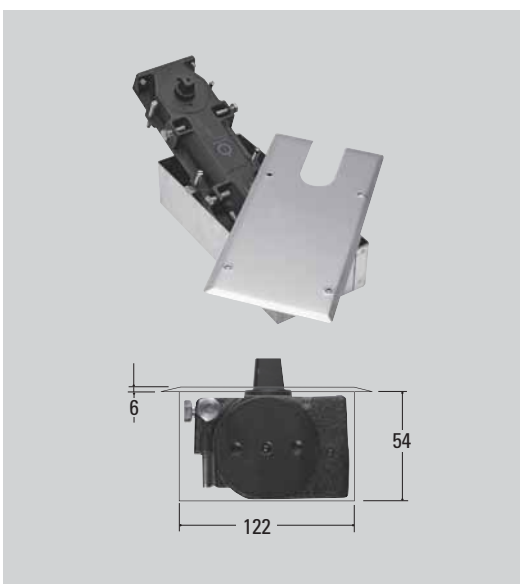
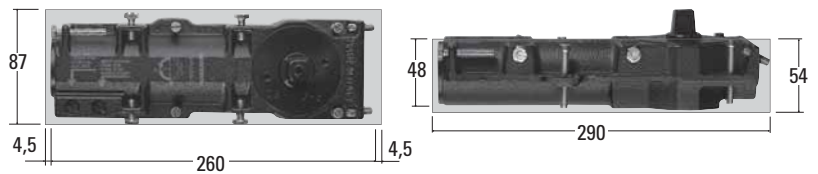
- Chiudiporta a pavimento con perno intercambiabile. Completo di perno italiano, scatola a cementare zincata e piastra in acciaio inox satinato AISI 304. Fermo a 90° - FORZA EN: 3 - Scatola 290x87x54 - Larghezza ANTA: mm. 900 - 1050.
- Floor spring with interchangeable pivot, Standard with italian square pivot, cover plate in satin stainless steel AISI 304. Hold open at 90° - Force 3. Cement box 290 x 87 x 54 - Door width range: mm. 900 - 1050.
- Bodentürschließer mit anstauschbaresteckachsen. Standard mit Italianischen Vierkant, einschließlich Zementkasten 290 x 87 x 54 und Deckplatte aus Edelstahl matt AISI 304 - Feststellung 90° - Türbreite mm 900 - 1050.

FV-S6003

- Chiudiporta a pavimento con perno intercambiabile. Completo di perno italiano, scatola a cementare zincata e piastra in acciaio inox satinato AISI 304. Fermo a 90° - FORZA EN: 3 - Scatola 273x122x65 - Larghezza. ANTA: mm. 900 - 1050.
- Floor spring with interchangeable pivot, Standard with italian square pivot, cover plate in satin stainless steel AISI 304. Hold open at 90° - Force 3 Cement box 273x122x65. Door width range: mm. 900 - 1050.
- Bodentürschließer mit anstauschbaresteckachsen. Standard mit Italianischen Vierkant, einschließlich Zementkasten 273 x 122 x 65 und Deckplatte aus Edelstahl matt AISI 304 - Feststellung 90° - Türbreite mm 900 - 1050.

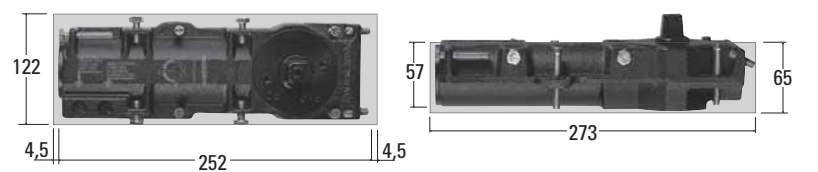

Le informazioni tecniche in questo catalogo potrebbero non sempre corrispondere con gli attuali colori, misure e dimensioni. Noi perseguiamo una politica di costante innovazione e miglioramento e ci riserviamo il diritto di modificare specifiche e disponibilità senza preavviso. Non abbiamo nessuna responsabilità per errori di stampa che possono essere occorsi nella realizzazione di questo catalogo. Essendo questo solo un catalogo grafico per la foratura del vetro bisogna fare riferimento al manuale tecnico.

Please note that the technical information included in this catalogue may not always precisely correspond with actual colours, measurements and dimensions. We pursue a policy of constant updating and improvement and reserve the right to alter specification and availability without notice. We take no responsibility for any printing errors that might be occurred in the completion of this catalogue.

Die in diesem Katalog angegebenen Maße, Abbildungen und Angaben, sind unverbindlich. Modelländerungen, Konstruktionsverbesserungen und Maßänderungen behalten wir uns vor. Erfahrungsgemäß können Druckfarben nicht immer den Farbton original getreu wiedergeben. Farbabweichungen sind daher möglich. Für Druckfehler wie auch übrige Fehler welche bei Erstellung dieses Kataloges entstanden sind, ist jede Haftung ausgeschlossen.

the 1990s, the number of people in the UK who are employed in the public sector has increased from 10.5 million to 12.5 million, and the number of people in the public sector who are employed in health care has increased from 2.5 million to 3.5 million (Department of Health 2000).

There are a number of reasons for this increase. One of the main reasons is the increasing demand for health care services. The population of the UK is ageing, and there is a growing number of people with chronic conditions such as diabetes, heart disease, and cancer. This has led to an increase in the number of people who need to be treated in hospitals and other health care settings.

Another reason for the increase is the expansion of the public sector. The government has invested heavily in health care over the past few decades, and this has led to an increase in the number of hospitals, clinics, and other health care facilities. This has created a need for more health care workers to staff these facilities.

There are also a number of other factors that have contributed to the increase in the number of health care workers. For example, there has been a growing emphasis on patient safety and quality of care, which has led to an increase in the number of health care workers who are trained in these areas. Additionally, there has been a growing emphasis on the role of health care workers in the prevention and management of chronic conditions, which has also led to an increase in the number of health care workers.

Despite the increase in the number of health care workers, there is still a significant shortage of health care workers in many areas. This is particularly true in the areas of nursing, medicine, and allied health professions. The shortage of health care workers is a major problem for the health care system, and it is one of the reasons why the government has invested so heavily in health care over the past few decades.

There are a number of reasons for the shortage of health care workers. One of the main reasons is the increasing demand for health care services. The population of the UK is ageing, and there is a growing number of people with chronic conditions. This has led to an increase in the number of people who need to be treated in hospitals and other health care settings, which has created a need for more health care workers.

Another reason for the shortage is the expansion of the public sector. The government has invested heavily in health care over the past few decades, and this has led to an increase in the number of hospitals, clinics, and other health care facilities. This has created a need for more health care workers to staff these facilities.

There are also a number of other factors that have contributed to the shortage of health care workers. For example, there has been a growing emphasis on patient safety and quality of care, which has led to an increase in the number of health care workers who are trained in these areas. Additionally, there has been a growing emphasis on the role of health care workers in the prevention and management of chronic conditions, which has also led to an increase in the number of health care workers.



METALGLAS BONOMI srl

Via Montini, 106/A - 25067 Lumezzane S.A. (Brescia) Italy

Ph. +39 030 829910 - Fax +39 030 8920970

www.metalglas.it - info@metalglas.it