

BOX DOCCIA

BOX DOCCIA
SHOWER BOX
DUSCHKABINEN

B



04/2022



BOX DOCCIA

INDICE / INDEX / INHALT



I NUOVI CATALOGHI METALGLAS BONOMI E I NUOVI LISTINI	2
<i>THE NEW CATALOGS METALGLAS BONOMI AND NEW PRICE LISTS</i>	
<i>DIE NEUEN KATALOGE METALGLAS BONOMI UND NEUE PREISLISTEN</i>	
DAL CATALOGO AL LISTINO CON UN SEMPLICE CODICE	4
<i>FROM THE CATALOG TO THE LIST WITH A SIMPLE CODE</i>	
<i>VOM KATALOG ZUR LISTE MIT EINEM EINFACHEN CODE</i>	
LEGENDA SIMBOLI	6
<i>SYMBOL LEGEND</i>	
<i>SYMBOLLEGENDE</i>	
LEGENDA ABBREVIAZIONI	7
<i>ACRONYM LEGEND</i>	
<i>ERKLÄRUNG DER ABKÜRZUNGEN</i>	
FINITURE	7
<i>FINISHES</i>	
<i>OBERFLÄCHEN</i>	
<hr/>	
B BOX DOCCIA	8
<i>SHOWER BOX</i>	
<i>DUSCHKABINE</i>	
GUIDA TECNICA PER LA SCELTA DEL VOSTRO SISTEMA	10
<i>TECHNICAL GUIDE FOR THE CHOICE OF YOUR SYSTEM</i>	
<i>AUSWAHL VON SCHIEBETÜRSYSTEMEN NACH VORHANDENEN KRITERIEN</i>	

I NUOVI CATALOGHI METALGLAS BONOMI

THE NEW CATALOGS METALGLAS BONOMI
DIE NEUEN KATALOGE METALGLAS BONOMI



SCORREVOLI

A | SISTEMI SCORREVOLI
SLIDING DOOR SYSTEMS
SCHIEBETÜRSYSTEME



BOX DOCCIA

B | BOX DOCCIA
SHOWER BOX
DUSCHKABINE

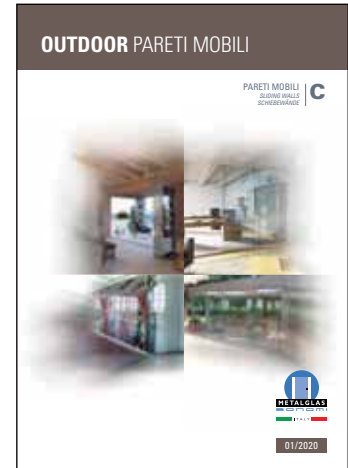

OUTDOOR PARETI MOBILI

C | PARETI MOBILI
SLIDING WALLS
SCHIEBEWÄNDE

... E I NUOVI LISTINI PREZZI

... AND NEW PRICE LISTS
... UND NEUE PREISLISTEN

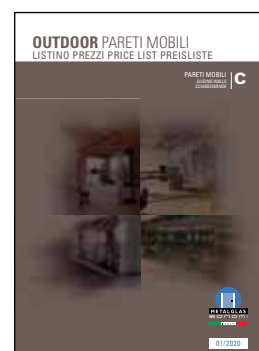
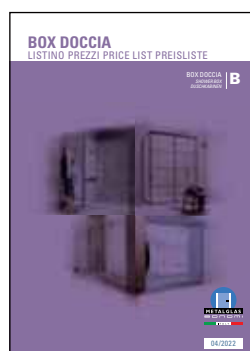



INDOOR

- D** PARETI DIVISORIE E STIPITI
PARTITION WALLS AND FRAMES
TRENNWÄNDE UND ALUMINIUMZARGEN
- E** SERRATURE E CERNIERE
LOCKS AND HINGES
SCHLÖSSER UND BÄNDER
- F** MANIGLIE MANIGLIONI POMOLI
DOORHANDLES PULLHANDLES KNOBS
TÜRGRIFFE STOSSGRIFFE KNÖPFE
- G** PORTE ESTERNE
PATCH FITTINGS
GANZGLASANLAGEN

OUTDOOR BALAUSTR E PENSILINE

- H** BALAUSTR E PENSILINE
RAILING AND CANOPY SYSTEMS
GANZGLASGÄLÄNDER UND VORDACHSYSTEME
- I** DISTANZIALI MORSETTI ACCESSORI
POINT FITTINGS CLAMPS ACCESSORIES
PUNKTHALTERUNG KLEMMBEFESTIGUNGEN ZUBEHÖRE

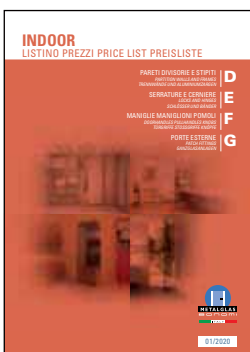

DAL CATALOGO AL LISTINO CON UN SEMPLICE CODICE

FROM THE CATALOG TO THE LIST WITH A SIMPLE CODE
VOM KATALOG ZUR LISTE MIT EINEM EINFACHEN CODE

SEARCH FOR THE CODE
OF EVERY PRODUCT IN
CATALOG...

*(ERCA IL CODICE
DI OGNI PRODOTTO NEL
CATALOGO...)*

SUCHE NACH DEM CODE
VON JEDEM PRODUKT IN
KATALOG ...



COMPONENTI / COMPONENTS / EINZELTEILE ▶ 12

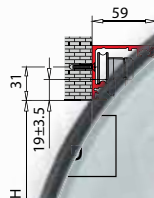

SET 1 € ▶ A.01 € ▶ A.03

V-5500
• Saggio a parete/soffitto
• Installation
• Sliding
• Schieb-
• Deckenmontage

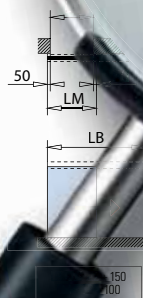

$LB = LP \times 2 + 100$
 $LM = (LP + 100) / 2$

	Fin. Fin. Oberf.	V-5500 V-5510 SET 1 FIX	V-5500 V-5510 SET 1 MIS	V-5500 V-5510 SET 2 FIX	V-5500 V-5510 SET 2 MIS
L=2000 L=3000 L=4000 L=6000	AN / IXE	1	1	1	1
MIS L=1500 → 6000	AN / IXE	1	1	1	1
L=2000	AN / IXE	1	1	2	2
V-5506-70 (V-5500)-70 Kg V-5506-50 (V-5510)-50 Kg	AN / IXE	1	1	2	2
V-5501	AN / IXE	1	1	1	1
V-012	AN / NS	1	1	2	2

V-5500 **70 Kg**

A. 01

SLIDING 14/15

FIN.	EURO	FIN.	EURO	FIN.	EURO
AN	361,00 /set	IXE	416,70 /set		
AN	422,30 /set	IXE	502,70 /set		
AN	482,30 /set	IXE	588,50 /set		
AN	473,30 /set	IXE	563,30 /set		
AN	682,30 /set	IXE	858,70 /set		
AN	628,00 /set	IXE	712,30 /set		
AN	688,50 /set	IXE	798,00 /set		
AN	816,00 /set	IXE	976,00 /set		
AN	678,30 /set	IXE	769,00 /set		
AN	881,00 /set	IXE	1054,00 /set		

SLIDING 14/15

mm	1 set	AN	IXE	EURO
2000 mm	1 set	AN 361,00 /set	IXE 416,70 /set	
3000 mm	1 set	AN 422,30 /set	IXE 502,70 /set	
4000 mm	1 set	AN 482,30 /set	IXE 588,50 /set	
1500 → 3000 mm	1 set	AN 473,30 /set	IXE 563,30 /set	
3000 → 6000 mm	1 set	AN 682,30 /set	IXE 858,70 /set	
3000 mm	1 set	AN 628,00 /set	IXE 712,30 /set	
4000 mm	1 set	AN 688,50 /set	IXE 798,00 /set	
6000 mm	1 set	AN 816,00 /set	IXE 976,00 /set	
1500 → 3000 mm	1 set	AN 678,30 /set	IXE 769,00 /set	
3000 → 6000 mm	1 set	AN 881,00 /set	IXE 1054,00 /set	

V-5503 **70 Kg** **50 Kg**

SLIDING 14/15

mm	1 set	AN	IXE	EURO
2000 mm	1 set	AN 377,30 /set	IXE 432,00 /set	
3000 mm	1 set	AN 477,00 /set	IXE 526,50 /set	
4000 mm	1 set	AN 516,70 /set	IXE 621,00 /set	
6000 mm	1 set	AN 659,50 /set	IXE 813,30 /set	
1500 → 3000 mm	1 set	AN 500,70 /set	IXE 589,70 /set	
3000 → 6000 mm	1 set	AN 738,70 /set	IXE 912,00 /set	
3000 mm	1 set	AN 653,50 /set	IXE 769,00 /set	
4000 mm	1 set	AN 723,30 /set	IXE 858,70 /set	
6000 mm	1 set	AN 866,00 /set	IXE 1014,00 /set	
1500 → 3000 mm	1 set	AN 706,00 /set	IXE 813,30 /set	
3000 → 6000 mm	1 set	AN 935,30 /set	IXE 1094,00 /set	

6

- FIX**
 - Confezioni industriali
 - Industrial packaging
 - Industrieverpackungen
- MIS**
 - Tagliato a misura del cliente
 - Custom length
 - Nach Mass geschnitten
- SLIDING 14/15**
 - Tagliato dal cliente
 - Cut by installer
 - Schnitt bausteilig
- 70 Kg**
 - Trasporto fuori stanza
 - Non-standard transport
 - Sondertransport

V-5513 **70 Kg** **50 Kg**

COMPONENTI / COMPONENTS / EINZELTEILE

POS.	PROD.	ART.	MIS.
A. 07	V-5513 SET 1 FIX		2000 mm 3000 mm 4000 mm 6000 mm
A. 08	V-5513 SET 2 FIX		1500 → 3000 mm 3000 → 6000 mm
A. 09	V-5500		2000 mm 3000 mm 4000 mm 6000 mm
A. 10	V-5503		1500 → 3000 mm 3000 → 6000 mm
A. 11	V-5502		1500 → 3000 mm 3000 → 6000 mm
A. 12	V-5506-70		1500 → 3000 mm 3000 → 6000 mm

... **RITROVERAI VELOCEMENTE**
LO STESSO CODICE NEL
LISTINO

YOU'LL FIND QUICKLY
 THE SAME CODE
 IN THE PRICE LIST

... SIE FINDEN SCHNELL
 DEN GLEICHEN CODE
 IN DER PREISLISTE

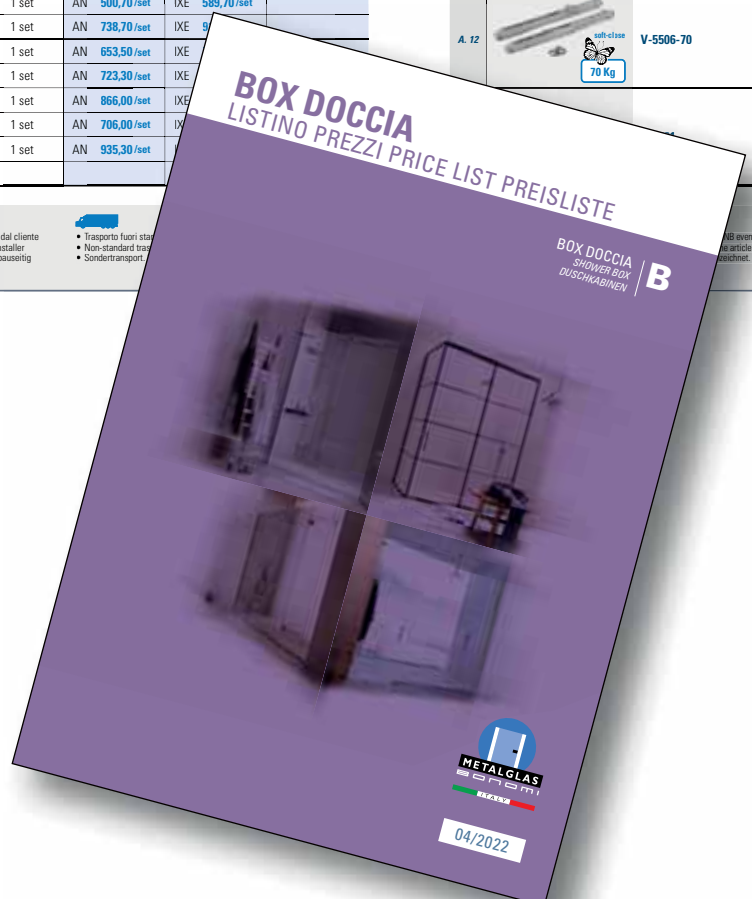

LEGENDA SIMBOLI

SYMBOL LEGEND

SYMBOLLEGENDE



8-10

SPESSORE VETRO
GLASS THICKNESS
GLASDICKE



1000

MISURE ANTA
PANEL MEASURES
TÜRGRÖSSE



70 Kg

PORTATA
LOAD CAPACITY
TRAGKRAFT



SISTEMA SOFT-CLOSE
SOFT-CLOSE SYSTEM
SOFT-CLOSE SYSTEM



70 Kg

PORTATA DEL SISTEMA SOFT-CLOSE
LOAD CAPACITY OF THE SOFT-CLOSE SYSTEM
TRAGKRAFT DES SOFT-CLOSE SYSTEMS

FIXED

ANTA FISSA
FIXED PANEL
SEITENTEIL



ANTA SCORREVOLE
SLIDING DOOR
SCHIEBETÜR

FIX

LUNGHEZZA FISSA
FIXED LENGTH
FESTE LÄNGE

MIS 

TAGLIATO A MISURA DEL CLIENTE
CUSTOM LENGTH
NACH MASS GESCHNITTEN

MY METALGLAS

**CONFIGURATORE ESCLUSIVO
METALGLAS PER SEMPLIFICARE
LA REALIZZAZIONE DI SISTEMI
IN VETRO TEMPERATO**

*EXCLUSIVE CONFIGURATOR METALGLAS
TO SIMPLIFY THE CREATION OF SYSTEMS
IN TEMPERED GLASS*

*EXKLUSIVER KONFIGURATOR METALGLAS
ZU VEREINFACHEN DIE ERSTELLUNG
VON SYSTEMEN AUS GEHÄRTETEM GLAS*

LEGENDA ABBREVIAZIONI

ACRONYM LEGEND

ERKLÄRUNG DER ABKÜRZUNGEN

L	PIATTO SHOWER TRAY DUSCHTASSE	HB	ALTEZZA FISSAGGIO BINARIO RAIL INSTALLATION HEIGHT LAUFSCIENENMONTAGE HÖHE
LP	PASSAGGIO LUCE CLEAR OPENING WIDTH LICHTE DURCHGANGSBREITE	LM/LV	LARGHEZZA VETRO GLASS WIDTH GLAS BREITE
H	ALTEZZA DOCCIA SHOWER HEIGHT DUSCHKABINE HÖHE	HV	ALTEZZA VETRO GLASS HEIGHT GLAS HÖHE
LA	LARGHEZZA ANTA MOBILE SLIDING DOOR WIDTH SCHIEBEFLÜGEL BREITE	LAF	LARGHEZZA ANTA FISSA FIXED GLASS WIDTH SEITENTEIL BREITE
HM	ALTEZZA ANTA MOBILE SLIDING GLASS HEIGHT SCHIEBEFLÜGEL HÖHE	HS	ALTEZZA STIPITE FRAME HEIGHT ZARGE HÖHE
HF	ALTEZZA VETRO FISSO SIDE FIXED GLASS HEIGHT SEITENTEIL HÖHE	LS	LARGHEZZA STIPITE FRAME WIDTH ZARGE BREITE
LF	LARGHEZZA VETRO FISSO FIXED GLASS WIDTH FESTGLASBREITE	HFA	ALTEZZA PROFILO VERTICALE ANTA FISSA VERTICAL PROFILE HEIGHT FIXED PANEL VERTIKALPROFIL HÖHE SEITENTEIL
HFL	ALTEZZA VETRO FISSO LATERALE SIDE FIXED GLASS HEIGHT GLASHÖHE SEITLICHE FESTVERGLASUNG	HA	ALTEZZA PROFILO VERTICALE ANTA SCORREVOLE VERTICAL PROFILE HEIGHT SLIDING PANEL VERTIKALPROFIL HÖHE SCHIEBEFLÜGEL
LB	LUNGHEZZA BINARIO RAIL LENGTH LAUFSCIENENLÄNGE		

FINITURE

FINISHES

OBERFLÄCHEN

	CP	CROMO PERLA CHROME PERLA SIMILAR ALU CHROM PERLA ÄHNLICH ALU		IX	ACCIAIO INOX SATINATO SATIN STAINLESS STEEL EDELSTAHL MATT
	CS	CROMO SATINATO SATIN CHROME CHROM MATT		IXE/ IXO	EFFETTO INOX SATINATO INOX EFFECT INOX EFFEKT
	NS	NICKEL SATINATO SATIN NICKEL ÄHNLICH EDELSTAHL MATT		IL	ACCIAIO INOX LUCIDO POLISHED STAINLESS STEEL EDELSTAHL POLIERT
	CR	CROMO LUCIDO POLISHED CHROME CHROM GLÄNZEND		NO	NERO OPACO MATT BLACK SCHWARZ MATT
	OL	OTTONE LUCIDO POLISHED BRASS MESSING POLIERT		OR	ORO OPACO MATT GOLD GOLD MATT
	AN	ALLUMINIO ANODIZZATO ALUMINIUM ANODIZED ALUMINIUM SILBERFARBIG		BI	BIANCO OPACO MATT WHITE WEISS MATT

BOX DOCCIA
SHOWER BOX
DUSCHKABINE

B

GUIDA TECNICA PER LA SCELTA DEL VOSTRO SISTEMA

TECHNICAL GUIDE FOR THE CHOICE OF YOUR SYSTEM

AUSWAHL VON SCHIEBETÜRSYSTEMEN NACH VORHANDENEN KRITERIEN

BOX DOCCIA CON SISTEMA SCORREVOLE
SHOWER BOX WITH SLIDING SYSTEM
DUSCHKABINE MIT SCHIEBETÜRSYSTEM

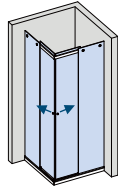

BX-DIV5000
SOFT-CLOSE

▶ 18

NEW

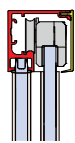

BX-5000 TINY
SOFT-CLOSE

▶ 48

NEW

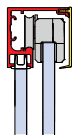

BX-4000 LINEA 30

▶ 60

NEW

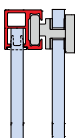

BX-6050 PURA

▶ 72

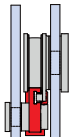

BX-6000 ETEREA
BX-6020 ETEREA
SOFT-CLOSE

▶ 82

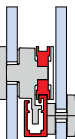

BX-1501

▶ 98

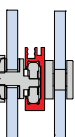

BOX DOCCIA SCORREVOLE A SOFFIETTO
SHOWER BOX WITH FOLDING DOOR
DUSCHKABINE MIT SYSTEM FÜR FALTÜREN

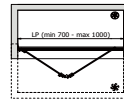
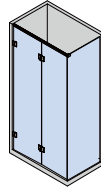

BX-2700

▶ 112

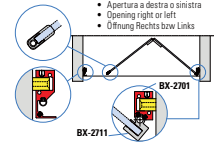

BX-2600

▶ 118

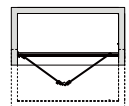

BOX DOCCIA CON ANTA A BATTENTE
(CERNIERA A SCATTO)

SHOWER BOX WITH SWING DOOR
(DOUBLE ACTION CLICKING HINGES)

DUSCHKABINE MIT DREH-TÜR
(SELBSTSCHLIESSENDE PENDELTÜRBÄNDER)

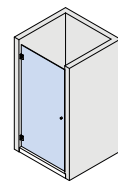

B-751 / B-752

▶ 125

NEW



B-753 / B-754

▶ 127

NEW



B-701

▶ 129



B-702

▶ 129



B-301

▶ 131



B-306

▶ 131



B-100 / B-101

B-102 / B-103

▶ 132 - 133



B-150

▶ 133



B-400 / B-401

B-402 / B-405

▶ 134 - 135



L-220

▶ 131



CERNIERE A SCATTO IN BATTUTA
SINGLE ACTION CLICKING HINGES
FOR CONTINUOUS SEALS
ANSCHLAGTÜRBÄNDER
FÜR DURCHGEHENDE DICHTUNG
(SELBSTSCHLIESSENDE BÄNDER)

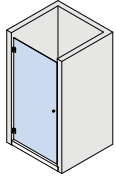

B-201
 ▶ 137



B-202
 ▶ 137



CERNIERE CON ALZATA IN APERTURA
HINGES WITH LIFT-LOWER FUNCTION
BÄNDER MIT HEBE-SENK-FUNKTION

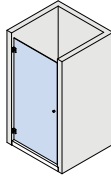

B-551 / B-553
 ▶ 138

NEW



B-552 / B-554
 ▶ 141

NEW



B-501 DX-SX
 ▶ 143

NEW



B-502 DX-SX
 ▶ 143

NEW



CERNIERE IN BATTUTA
(GUARNIZIONE CONTINUA)
HINGES FOR CONTINUOUS SEALS
ANSCHLAGTÜRBÄNDER
(DURCHGEHENDER DICHTUNG)

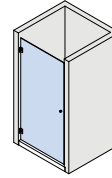

B-711
 ▶ 145



B-712
 ▶ 145



B-621
 ▶ 147

NEW



B-622
 ▶ 147

NEW



B-105
 ▶ 148



B-104
 ▶ 148



GUIDA TECNICA PER LA SCELTA DEL VOSTRO SISTEMA

TECHNICAL GUIDE FOR THE CHOICE OF YOUR SYSTEM

AUSWAHL VON SCHIEBETÜRSYSTEMEN NACH VORHANDENEN KRITERIEN

**PIVOT ALTO-BASSO (BILICO)
PORTA BATTENTE**
TOP/BOTTOM PIVOT HINGES
OBERE/UNTERE PIVOT BÄNDER

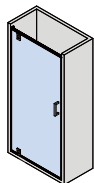

BX-2100 BILICO

▶ 150



B-304

▶ 154



BX-305

▶ 156



BX-303 BILICA

▶ 158



**PROFILI
PROFILES
PROFILE**

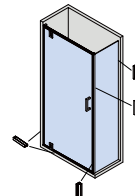

- PROFILI DI BATTUTA
 - DOOR STOP PROFILES
 - TÜRANSCHLAGSPROFILE
- ▶ 162



- PROFILI GOCCIOLATOIO
 - SPLASH GUARD PROFILES
 - SCHWALLSCHUTZ PROFILE
- ▶ 164



- PROFILI BORDO VETRO
 - CLOSURE PROFILE
 - VERTIKALE RAHMENPROFILE
- ▶ 165



- GUIDE A PAVIMENTO
 - FLOOR GUIDES
 - BODENFÜHRUNGEN
- ▶ 169



- CANALINE "U" IN ALLUMINIO
 - U PROFILES IN ALUMINIUM
 - U-PROFILE AUS ALUMINIUM
- ▶ 170

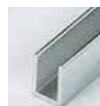

- CANALINE IN ACCIAIO
 - "U" PROFILES IN INOX
 - "U" PROFILE AUS INOX
- ▶ 170

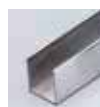

- CANALINE "U" CON BORDO RIPIEGATO
 - U PROFILES WITH FOLDED EDGE U-PROFILE
 - "U" PROFILE MIT ABGERUNDETER KANTE
- ▶ 172



- ANGOLARI
 - L PROFILES
 - L PROFILE
- ▶ 173



- CANALINE "U" CON ALETTA
 - U PROFILES WITH PLATE
 - U-PROFILE MIT PLATTE
- ▶ 173

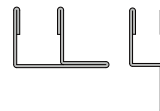
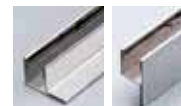

SEPARÉ
SEPARÉ
SEPARÉ

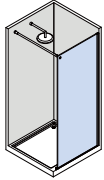

- BARRE DI SUPPORTO QUADRE REGOLABILI
- ADJUSTABLE SQUARE SUPPORT BARS
- VERSTELLBARE ECKIGE STABILISATIONSSTANGEN



► 180

- BARRE DI SUPPORTO QUADRE
- SQUARE SUPPORT BARS
- ECKIGE STABILISATIONSSTANGEN



► 184

- BARRE DI SUPPORTO TONDE
- ROUND SUPPORT BARS
- RUNDE STABILISATIONSSTANGEN



► 185

ACCESSORI
ACCESSORIES
ZUBEHÖRE

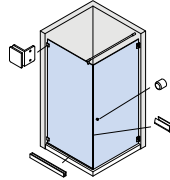

- MORSETTI
- CLAMPS
- KLEMMBESCHLÄGE



► 190

- RAGNETTI
- CONNECTORD
- VERBINDER



► 194

- GUARNIZIONI
- GASKETS
- DICHTUNGEN



► 196

- POMOLI
- KNOBS
- KNÖPFE



► 202

- NICCHIE
- KNOBS
- KNÖPFE



► 206

- MANIGLIONI
- PULLHANDLES
- STOSSGRIFFE



► 208

BOX DOCCIA CON SISTEMA SCORREVOLE

SHOWER BOX WITH SLIDING SYSTEM / DUSCHKABINE MIT SCHIEBETÜRSYSTEM

NEW

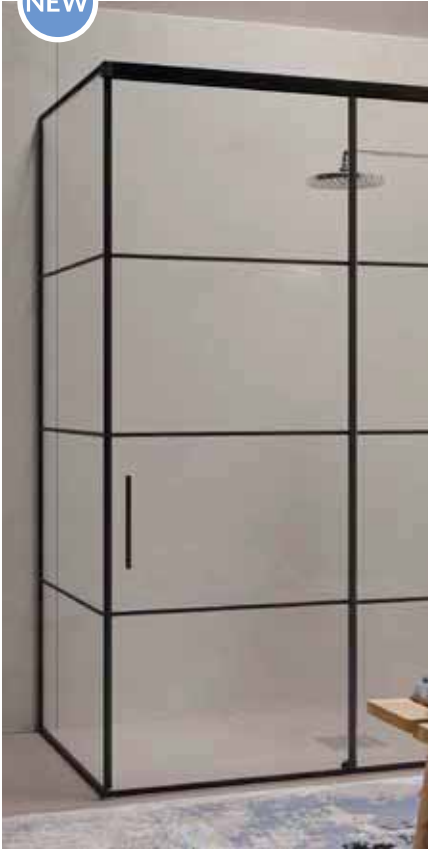

BX-DIV5000
(OPTIONAL SOFT-CLOSE)



► 18

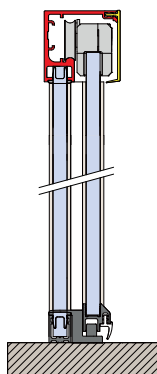

NEW



BX-5000 TINY
(OPTIONAL SOFT-CLOSE)



► 48

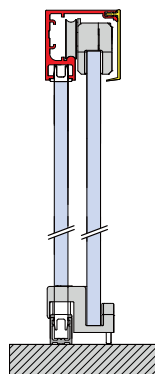

BX-4000 LINEA 30

► 60

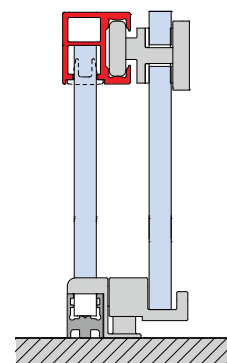

NEW



**BX-6050
PURA**

► 72

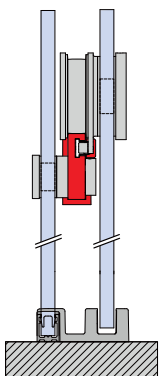

BX-6000

**BX-6020
SOFT-CLOSE**



► 82

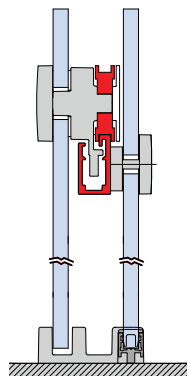

BX-1501

► 98

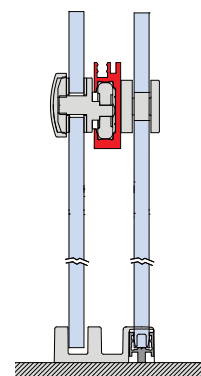

SCORREVOLI

GUIDA TECNICA PER LA SCELTA DEL TUO "PROFILO A TERRA" SECONDO TIPOLOGIE

TECHNICAL GUIDE FOR THE CHOICE OF YOUR "FLOOR PROFILE" BY TYPOLOGIES

AUSWAHL VON "BODENPROFIL" NACH VORHANDENEN KRITERIEN

Per i modelli: / For models: / Für Modelle:
BX-1501, BX-4000, BX-6000, BX-6020,
BX-5000, BX-6050, BX-DIV5000

SET 1

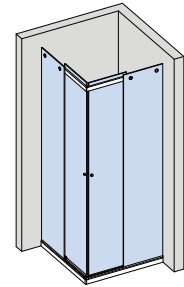

SCORREVOLI



BX-PT-01 STANDARD

- Vetro fisso nel profilo continuo H 16 mm.
- Fixed glass in shower entry floor profile H 16 mm.
- Festverglasung im Duscheinstieg Bodenprofil H 16 mm.

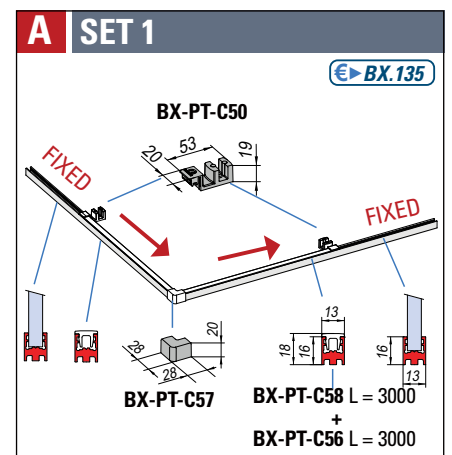
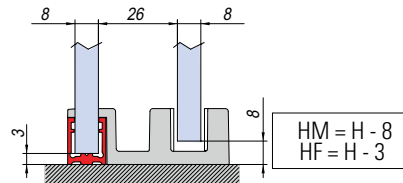

BX-PT-02 SOLO PORTA OPTIONAL

- Vetro fisso su piatto doccia, solo profilo entrata H 16 mm.
- Fixed glass on shower tray, only shower entry floor profile H 16 mm.
- Festverglasung auf Duschtasse, Duscheinstieg Bodenprofil H 16 mm.

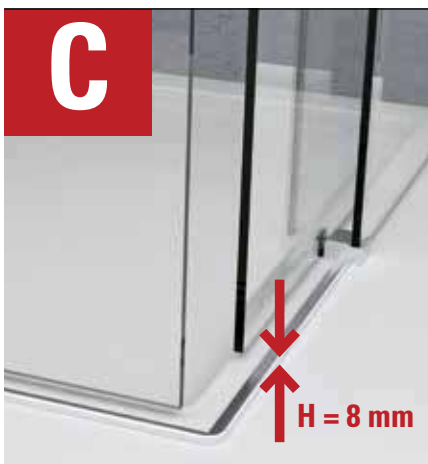
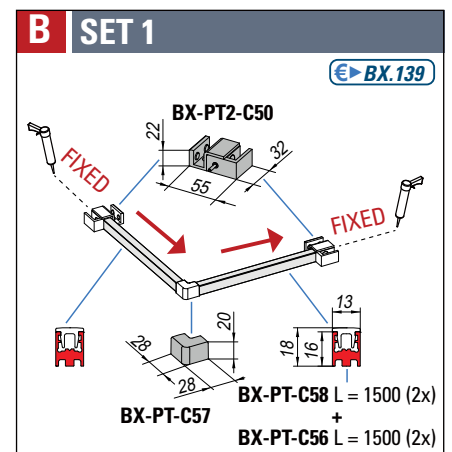
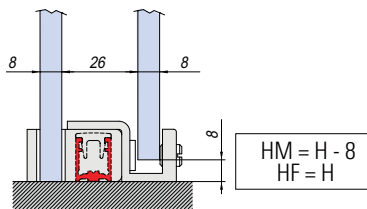

BX-PT-03 RASO DOCCIA OPTIONAL

- Vetro fisso su piatto doccia, profilo entrata H 8 mm.
- Fixed glass on shower tray, shower entry floor profile H 8 mm.
- Festverglasung auf Duschtasse, Duscheinstieg Bodenprofil H 8 mm.

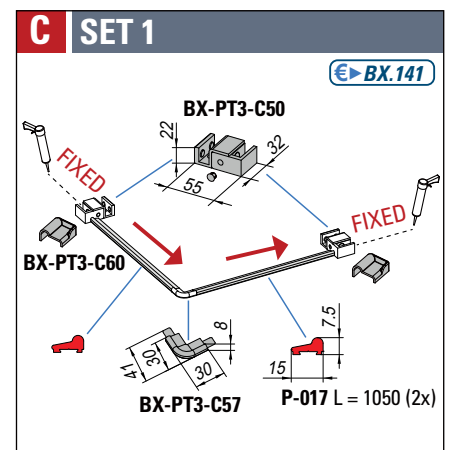
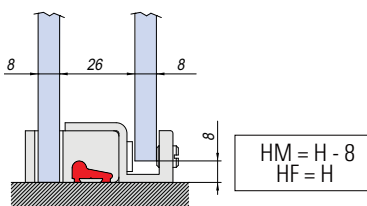

SCEGLIERE FONDO PREFERITO

CHOOSE FAVORITE FLOOR PROFILES / WÄHLEN SIE IHR GEWÜNSCHTES BODENPROFIL

SET 2

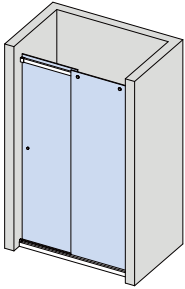

SET 3

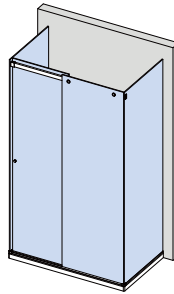

SET 4

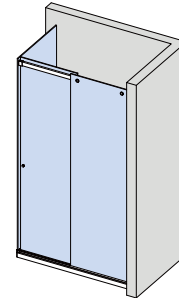

SCORREVOLI

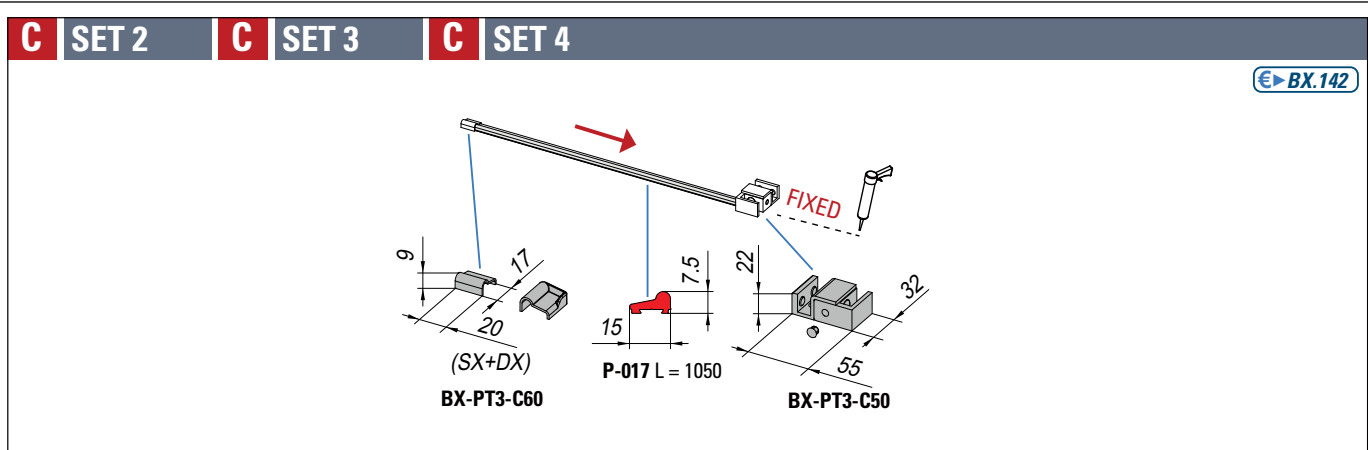
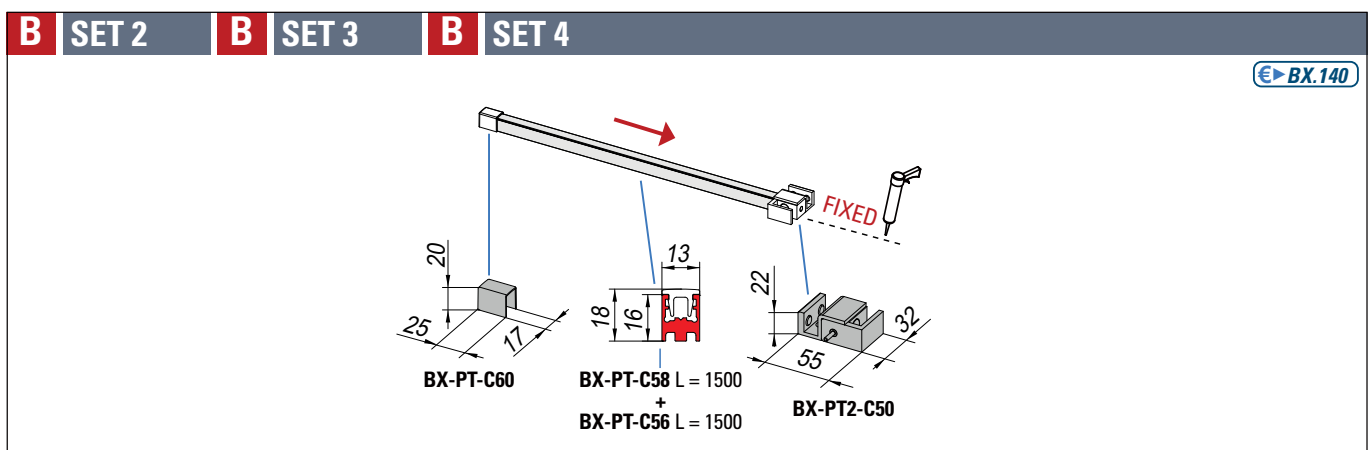
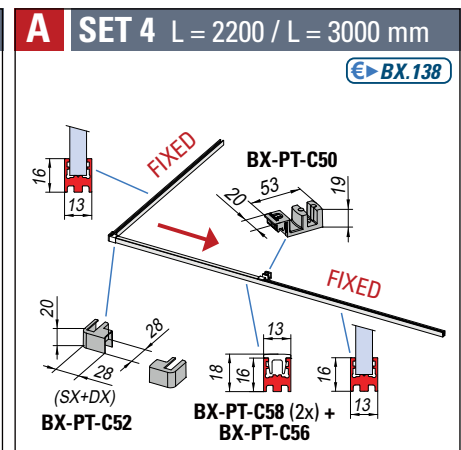
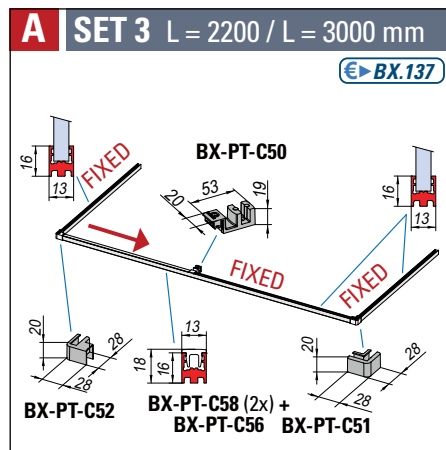
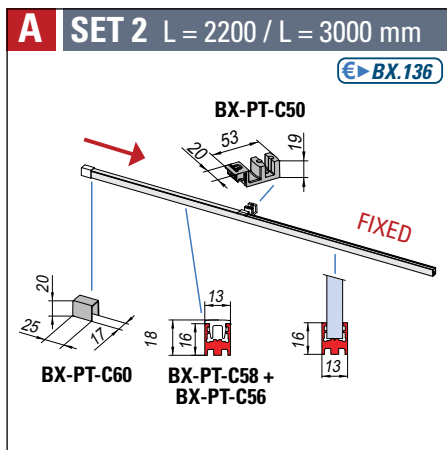

HM
Altezza vetro mobile
Sliding glass height
Schiebeflügel Höhe

HF
Altezza vetro fisso
Side fixed glass height
Seitenteil Höhe



SCORREVOLI



BX-DIV5000

Linee che si inseguono e si incrociano separando lo spazio, ma rendendolo, allo stesso tempo qualcosa di unico...questa è la nuova doccia intelaiata DIVINA.

FUNZIONALITÀ PERFETTA E GRANDE IMPATTO ESTETICO.

- Lines that chase each other and intersect, separating the space while making it something unique...this is the new framed shower enclosure DIVINA.
- Linien, die einander folgen und sich kreuzen, die den Raum trennen, ihn aber gleichzeitig zu etwas Einzigartigem machen... das ist die neue Rahmen-Dusche DIVINA.
- FUNCTIONALITY MEETS DESIGN.
- FUNKTIONALITÄT TRIFFT AUF DESIGN.

NEW

PLUS

- BINARIO ALTO SOLO 40 MM
- PROFILI ANTA MINIMALI
- PINZE REGOLABILI IN ALTEZZA +/- 2,5 MM
- VETRO FISSO INGLOBATO NEL BINARIO
- POSSIBILITÀ DI SOFT-CLOSE SIA IN APERTURA CHE IN CHIUSURA
- GUARNIZIONI INTEGRATE NEI PROFILI ANTA
- POSSIBILITÀ DI SGANCIARE LA GUIDA INFERIORE PER UNA PERFETTA PULIZIA
- AMPIA GAMMA DI COLORI

- Rail only 40 mm high
- Perimetral minimal size profiles
- Adjustable clamp height +/- 2,5 mm
- Fixed glass enclosed in the rail
- Possible soft-close in both opening and closure
- Panel profiles with integrated gaskets
- Quick release door function for easy cleaning
- Large choice of finishing colours

- Schienenhöhe nur 40 mm
- Rahmenprofile mit minimaler Grösse
- Höhenverstellbare Laufwagen +/- 2,5 mm
- Festes Glas in die Schiene eingebaut
- Soft-close beidseitig beim öffnen und schließen möglich
- Flügelprofile mit integrierten Dichtungen
- Die auslösbare Bodenführung erleichtert das Reinigen
- Grosse Auswahl an farbigen Oberflächen

BX-DIV5000 (OPTIONAL SOFT-CLOSE)



Un sistema di profili perimetrali e listelli intermedi per creare un'infinità di ante sempre diverse tra loro.

A system of frames and intermediate profiles to create an endless number of panels, all different from each other.

Ein System von Rahmenprofilen und Querleisten, um eine Vielzahl von Türen zu schaffen, die sich stets voneinander unterscheiden.



SCORREVOLI



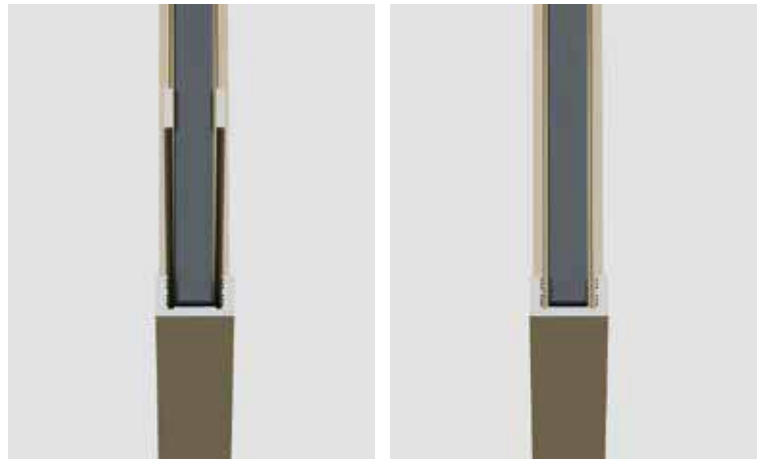

SCORREVOLI



BX-DIV5000 SET 2

SISTEMA
SYSTEM
SYSTEM

FIL-203
TRAVERSO
CROSS PROFILE
QUERPROFIL

OR
FINITURA
FINISHING
OBERFLÄCHE

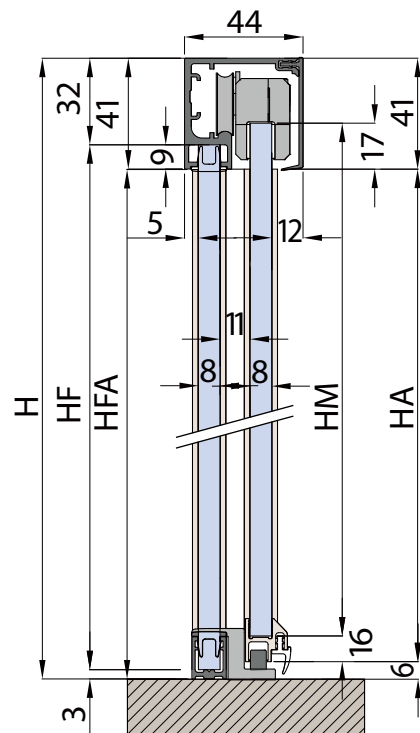

ESCLUSIVE DEL PROGETTO

EXCLUSIVE FEATURES OF THE PROJECT - EXKLUSIV FÜR DAS PROJEKT



SCORREVOLI

- Utilizzo dell'esclusivo programma MyMetalglas per lo sviluppo delle porte. **Misure vetri, profili e lavorazioni con un solo click.**
- Use of the exclusive MyMetalglas program for door design. **Glass measurements, profiles and processes with a single click.**
- Nutzung des exklusiven Programms MyMetalglas für die Türplanung. **Glasabmessungen, Profile und Verarbeitungen mit einem Klick.**

GAMMA FINITURE

FINISHING RANGE - OBERFLÄCHEN-SORTIMENT

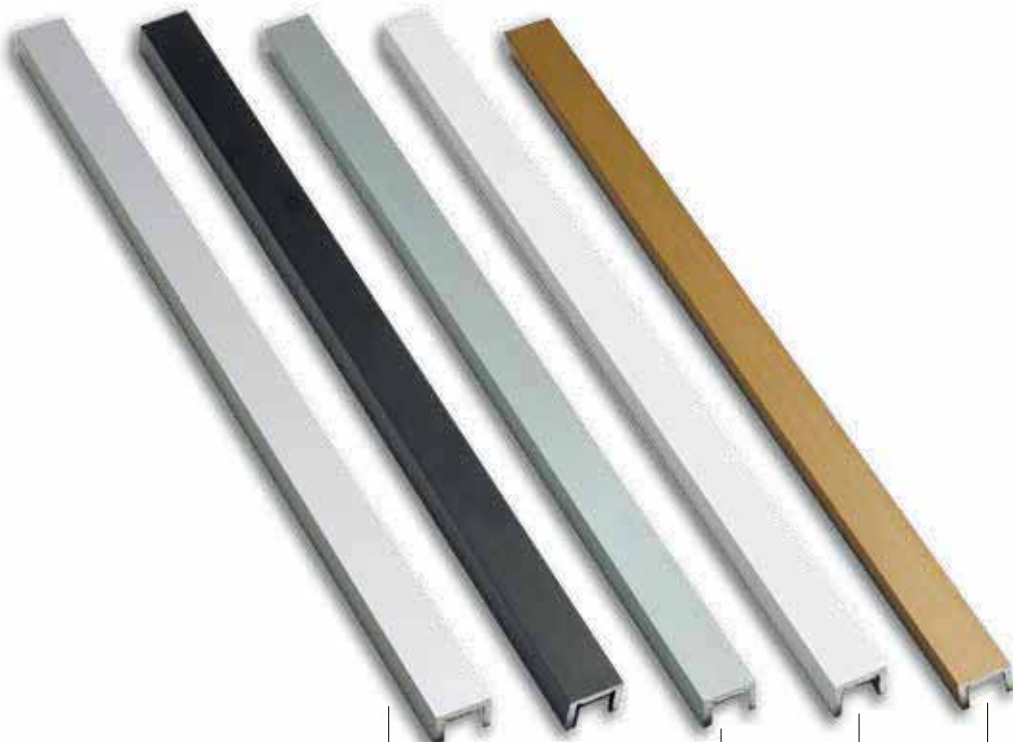

CROMO
LUCIDO

POLISHED CHROME
CHROM GLÄNZEND

CR

NERO
OPACO

MATT BLACK
SCHWARZ MATT

NO

EFFETTO
SATINATO
INOX

INOX EFFECT
INOX EFFEKT

IXE

BIANCO
OPACO

MATT WHITE
WEISS MATT

BI

ORO
OPACO

MATT GOLD
GOLD MATT

OR





SCOREVOLI

SET BOX DOCCIA SCORREVOLI

SHOWER BOX SET WITH SLIDING SYSTEM - SET DUSCHKABINE MIT SCHIEBETÜRSYSTEM

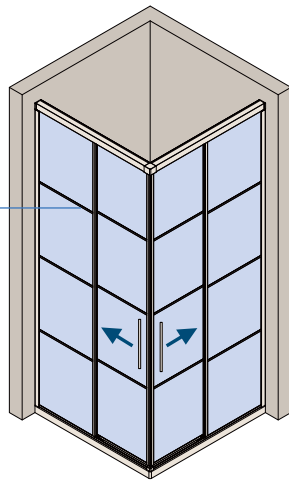

FIL-203
OPTIONAL

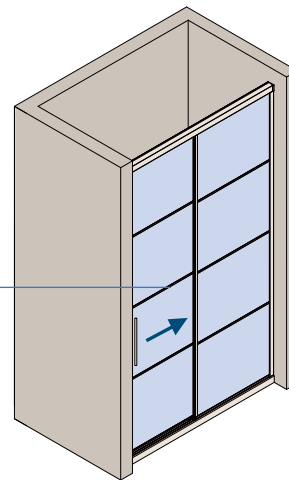

FIL-203
OPTIONAL

BX-DIV5000 SET 1 
SET DOCCIA AD ANGOLO
CON ANTE INTELAIATE, PROFILI A TERRA INCLUSI
SET FOR CORNER SHOWER WITH FRAMED PANELS, FLOOR PROFILES INCLUDED
SET ECKDUSCHE MIT GERAHMTEN FLÜGELN, BODENPROFILE ENTHALTEN

BX-DIV5000 SET 2 
SET DOCCIA IN NICCHIA
CON ANTE INTELAIATE, PROFILI A TERRA INCLUSI
SET FOR NICHE SHOWER WITH FRAMED PANELS, FLOOR PROFILES INCLUDED
SET NISCHENDUSCHE MIT GERAHMTEN FLÜGELN, BODENPROFILE ENTHALTEN

FIL-203 OPTIONAL 
TRAVERSO
CROSS PROFILE
QUERPROFIL

FIL-203 OPTIONAL 
TRAVERSO
CROSS PROFILE
QUERPROFIL

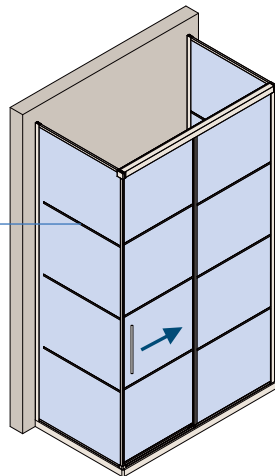

FIL-203
OPTIONAL

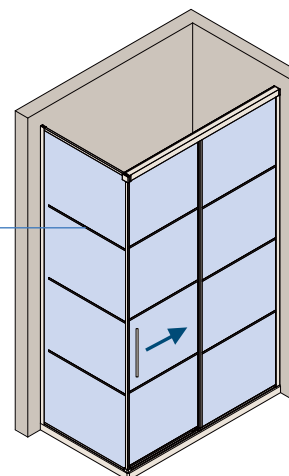

FIL-203
OPTIONAL

BX-DIV5000 SET 3 
SET DOCCIA A "U"
CON ANTE INTELAIATE, PROFILI A TERRA INCLUSI
SET FOR "U" SHOWER WITH FRAMED PANELS, FLOOR PROFILES INCLUDED
SET "U" DUSCHE MIT GERAHMTEN FLÜGELN, BODENPROFILE ENTHALTEN

BX-DIV5000 SET 4 
SET DOCCIA AD ANGOLO
CON 1 ANTA SCORREVOLE INTELAIATA, PROFILI A TERRA INCLUSI
SET FOR CORNER SHOWER WITH FRAMED PANELS FRONTAL ENTRY, FLOOR PROFILES INCLUDED
SET ECKDUSCHE FRONTEINSTIEG, MIT GERAHMTEN FLÜGELN BODENPROFILE ENTHALTEN

FIL-203 OPTIONAL 
TRAVERSO
CROSS PROFILE
QUERPROFIL

FIL-203 OPTIONAL 
TRAVERSO
CROSS PROFILE
QUERPROFIL



PROFILI (GUARNIZIONI INCLUSE)

PROFILES (GASKETS INCLUDED) - PROFILE (DICHTUNGEN ENTHALTEN)

BX-DIV-502

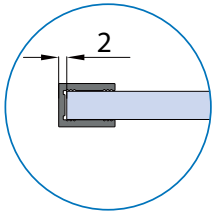
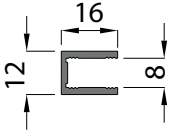

BX-DIV-526

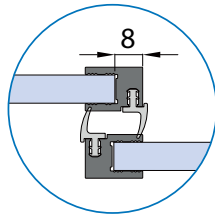
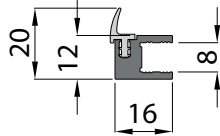

BX-DIV-527

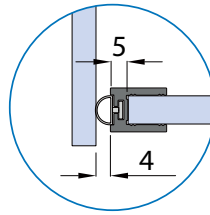
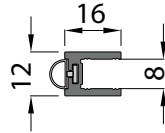

BX-DIV-543

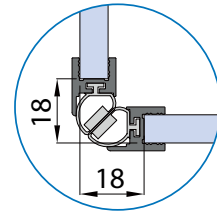
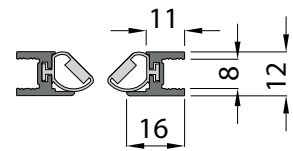

BX-DIV-519

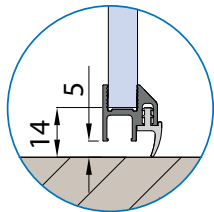
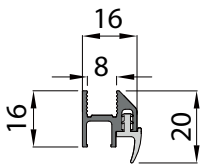

BX-PT-C58

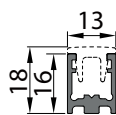

FIL-203

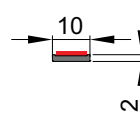

 Biadesivo preinstallato
 Pre-installed
 double-sided adhesive
 Selbstklebend

SCORREVOLI

COMPOSIZIONE ANTE E PROFILI A TERRA

PANELS' LAYOUT AND FLOOR PROFILES - FLÜGEL LAYOUT UND BODENPROFILE

MY METALGLAS

Componi la tua ante per quantificare i traversini da ordinare
Configure your panel to calculate the cross profiles
Konfigurieren Sie Ihre Tür und berechnen Sie automatisch die Querprofile

SET 1

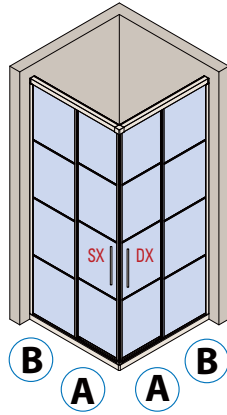

BX-PT-01 set 1

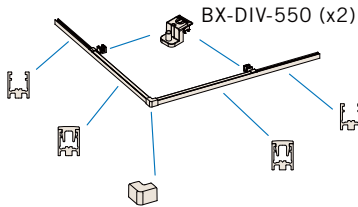

SET 2

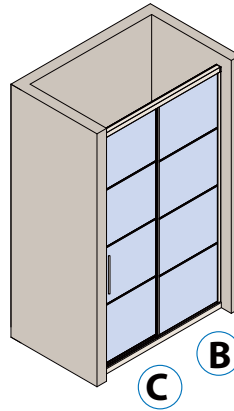

BX-PT-01 set 2

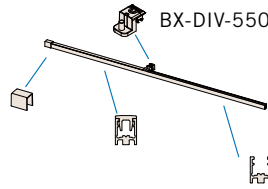

SET 3

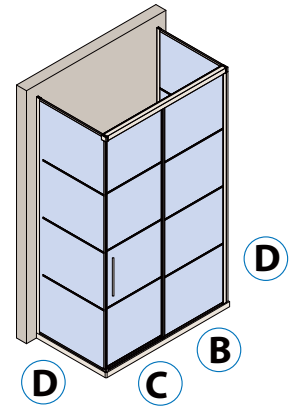

BX-PT-01 set 3

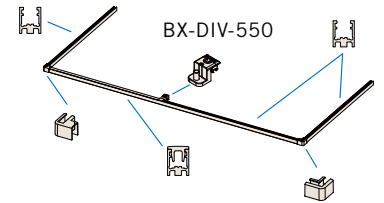

SET 4

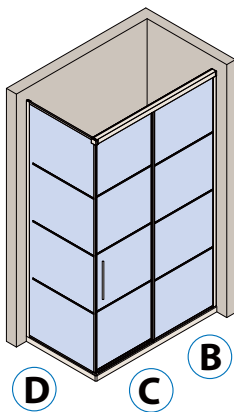

BX-PT-01 set 4

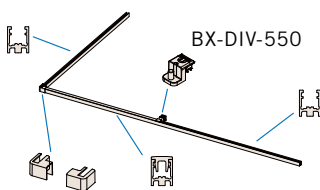

SET 5

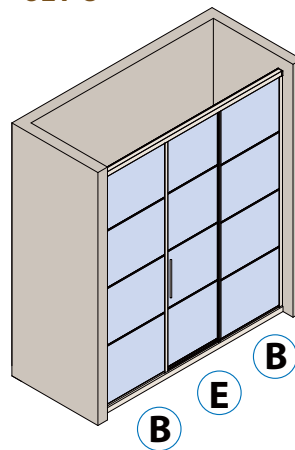

BX-PT-01 set 5

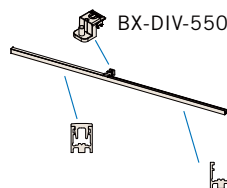

SET 6

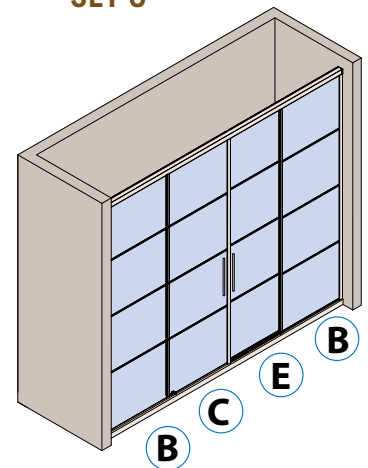

BX-PT-01 set 6

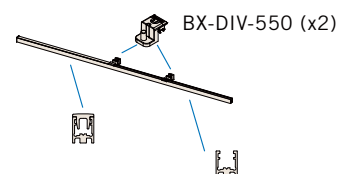

SCORREVOLI

BX-DIV-ANT-A-DX
BX-DIV-ANT-A-SX
ANTA SCORREVOLE A
SLIDING PANEL A
SCHIEBETÜR A

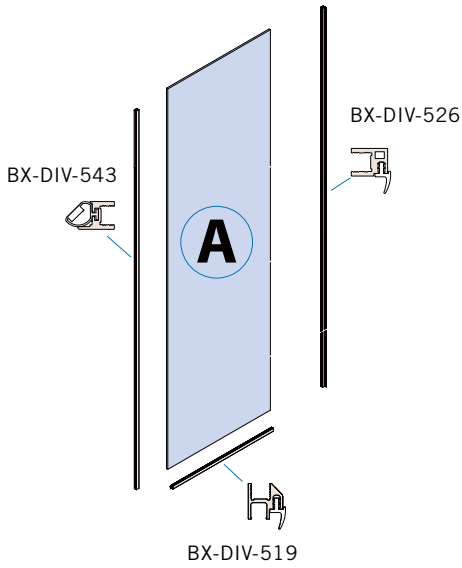

BX-DIV-ANT-B
ANTA FISSA B
FIXED PANEL B
SEITENTEIL B

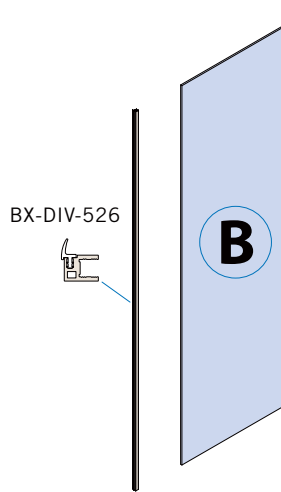

BX-DIV-ANT-C
ANTA SCORREVOLE C
SLIDING PANEL C
SCHIEBETÜR C

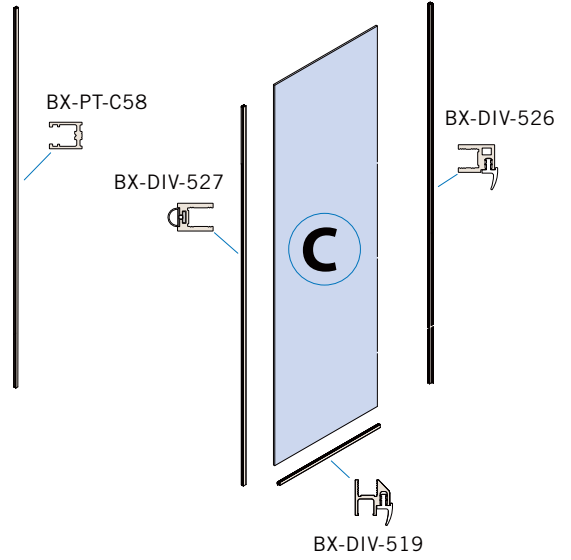

SCORREVOLI

BX-DIV-ANT-D
ANTA FISSA LATERALE D
FLATERAL FIXED PANEL D
SEITENTEIL D

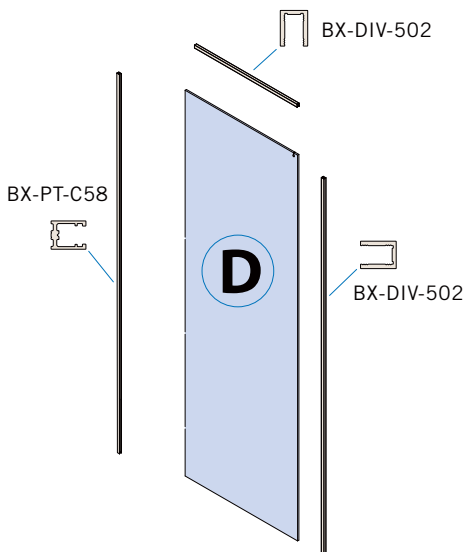

BX-DIV-ANT-E
ANTA SCORREVOLE E
SLIDING PANEL E
SCHIEBETÜR E

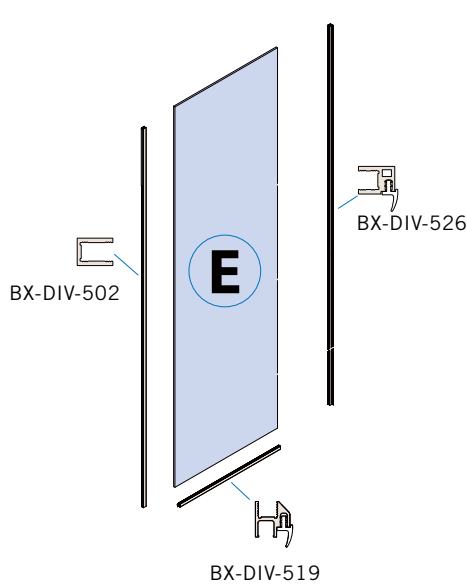

FIL-203 OPTIONAL
TRAVERSO
CROSS PROFILE
QUERPROFIL

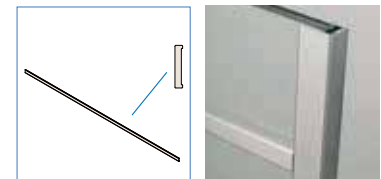

MANIGLIE

HANDLES - GRIFFE

DIV-007



DIV-008



V-526

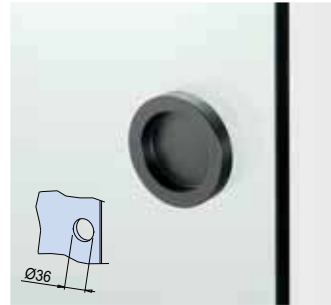

POR-0408



B-196

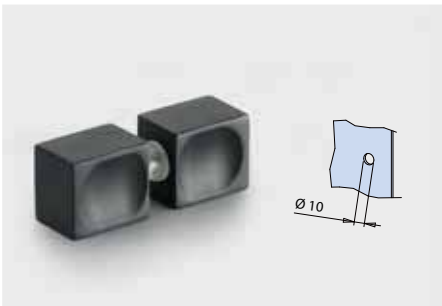

SCORREVOLI

FINITURE

FINISHES - OBERFLÄCHEN

CR



NO

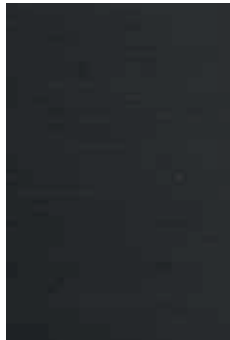

IXE/NS



BI



OR





BX-DIV5000 SET 1 L = 1000 X 1000 MM

DOCCIA IN ANGOLO - CORNER SHOWER - ECKDUSCHE **€ BX.1**

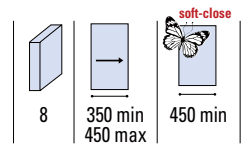

MY METALGLAS

FINITURE - FINISHING - OBERFLÄCHEN: CR - NO - IXE - BI - OR ▶ 22

COMPONENTI - COMPONENTS - EINZELTEILE

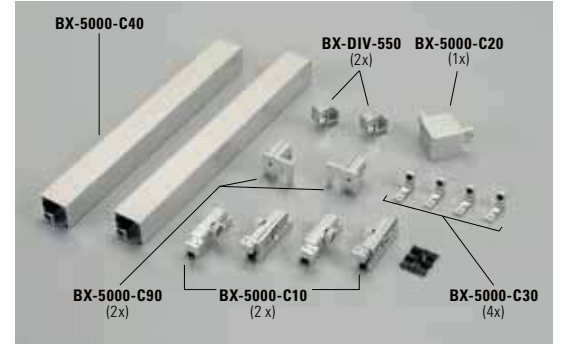
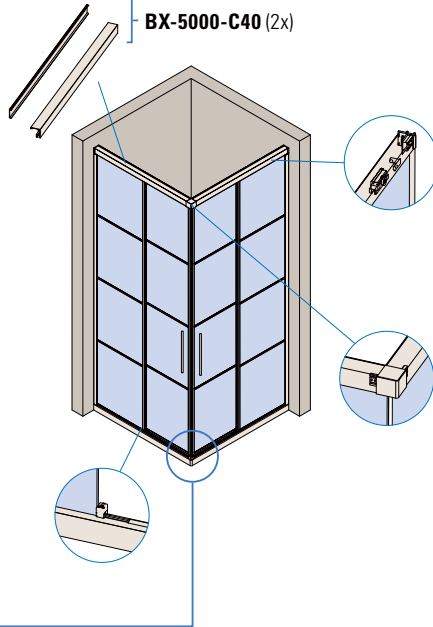
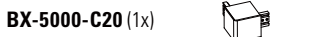
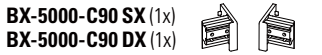
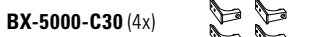
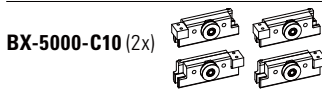

CARATTERISTICHE COMPONENTI
FEATURES COMPONENTS - EIGENSCHAFTEN EINZELTEILE
▶ 42

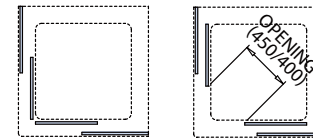
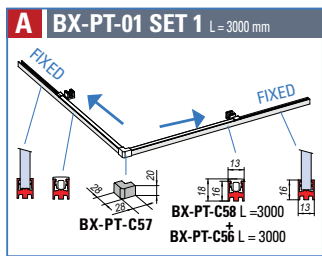

PROFILI A TERRA
FLOOR PROFILES - BODENPROFILE
▶ 106

xme632e

LAVORAZIONE PROFILI ANTA - PANEL PROFILES PREPARATION - FLÜGELPROFILE BEARBEITUNG

BX-DIV-ANT-A-DX BX-DIV-ANT-A-SX

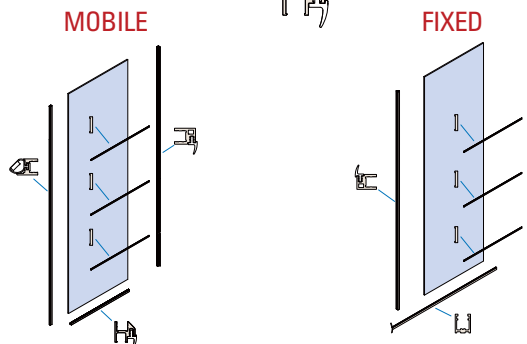
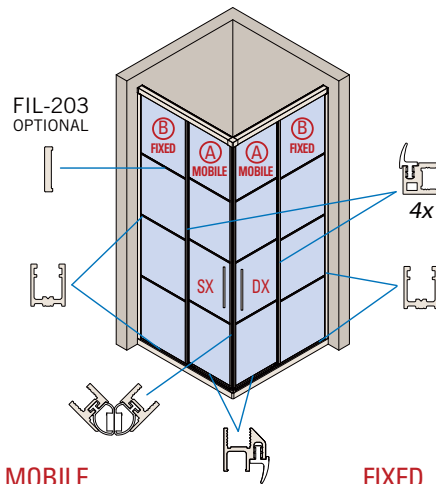
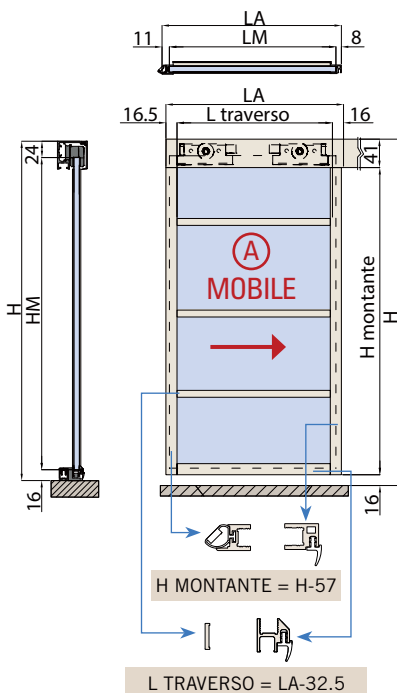

BX-DIV-ANT-B

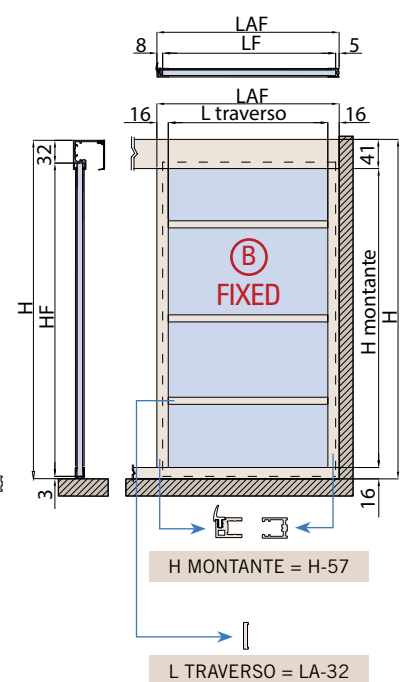

xme632a/xme632d

L Piatto Shower tray Duschtaße	LM Larghezza vetro mobile Sliding glass width Glasbreite-Schiebefügel	LF Larghezza vetro fisso Side fixed glass width Festglasbreite	HM Altezza vetro mobile Sliding glass height Schiebefügel Höhe	HF Altezza vetro fisso Side fixed glass height Glashöhe Festverglasung
--	---	--	--	--

SCORREVOLI

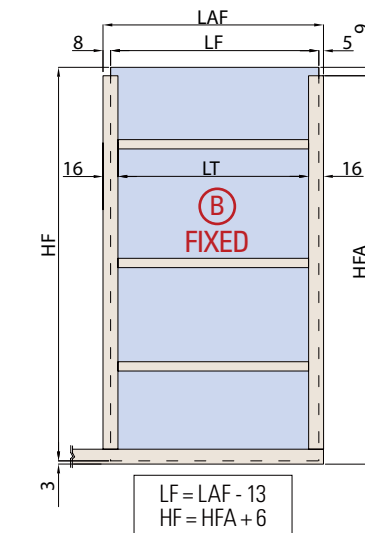
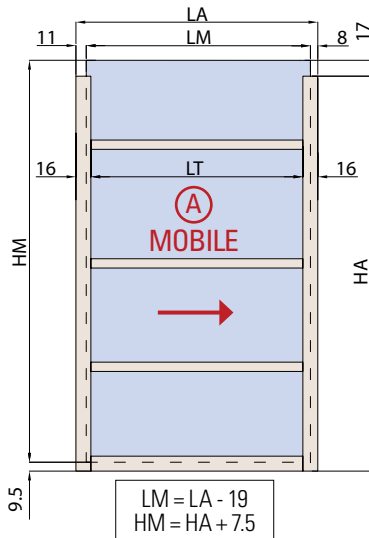
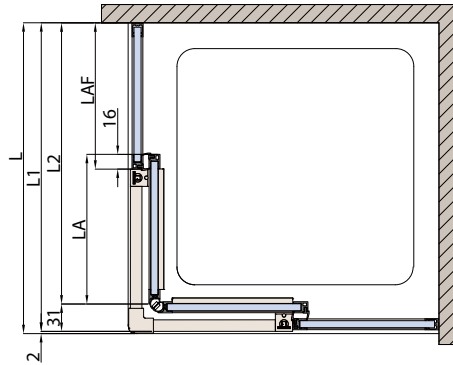
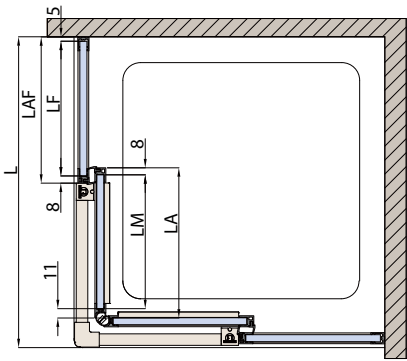
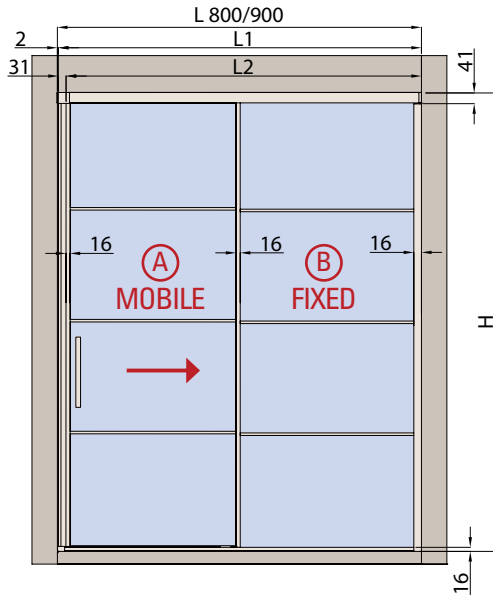
LAVORAZIONE VETRO - GLASS PREPARATION - GLASBEARBEITUNG

CALCOLO VETRO - CALCULATION GLASS - GLASBERECHNUNG

PIATTO - SHOWER TRAY - DUSCHTASSE (L) = 800 - 900 mm

 $L1 = L - 2$ $HA = H - 47$
 $L2 = L1 - 31$ $HFA = H - 41$
 $LA = LAF = (L2 + 16) / 2$
PROFILI A TERRA - FLOOR PROFILES - BODENPROFILE ▶ 106
A BX-PT-01 STANDARD HF = H - 35

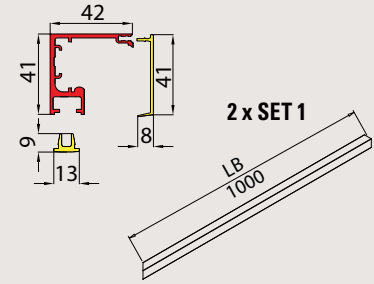
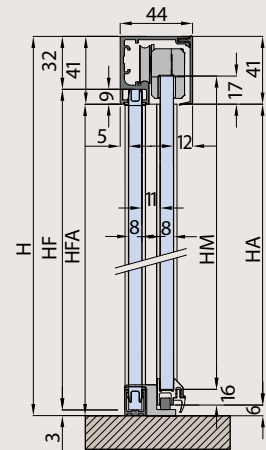
SET 1

 DA TAGLIARE ✂
 ADJUST THE LENGTH
 BELIEBIG KÜRZBAR

 REGOLAZIONE RUOTA ± 2 MM.
 ADJUSTMENT ± 2 MM.
 VERSTELLUNG ± 2 MM.

 $HM = H - 40$ $HA = H - 47$
 $HF = H - 35$ $HFA = H - 41$
OPTIONAL



xme632m

H Altezza doccia Shower height Duschkabine Höhe	LA Larghezza anta mobile Sliding door width Schiebeflügel Breite	HA Altezza profilo verticale anta scorrevole Vertical profile height sliding panel Vertikalprofil Höhe Schiebeflügel	LAF Larghezza anta fissa Fixed panel width Seitenteil Breite	HFA Altezza profilo verticale anta fissa Vertical profile height fixed panel Vertikalprofil Höhe Seitenteil
---	--	--	--	---

SCORREVOLI

BX-DIV5000 SET 2 L = 1500 MM / L = 3000 MM

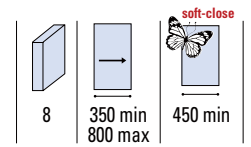
DOCCIA IN NICCHIA - NICHE SHOWER - NISCHENDUSCHE **► BX.2**



FINITURE - FINISHING - OBERFLÄCHEN: CR - NO - IXE - BI - OR ► 22

MY METALGLAS

COMPONENTI - COMPONENTS - EINZELTEILE

- BX-5000-C10** (1x)
- BX-5000-C30** (2x)
- BX-5000-C90 SX** (1x)
BX-5000-C90 DX (1x)
- BX-DIV-550** (1x)
- BX-5006** (1x) **OPTIONAL SOFT-CLOSE**
- OPTIONAL** (1x)

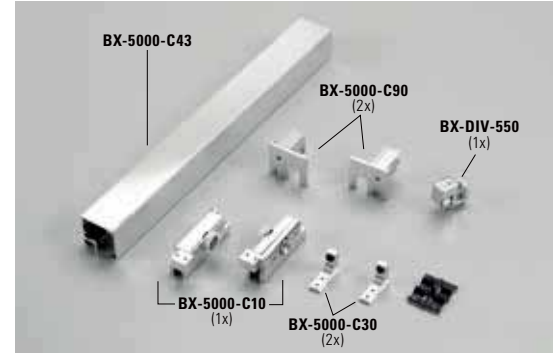
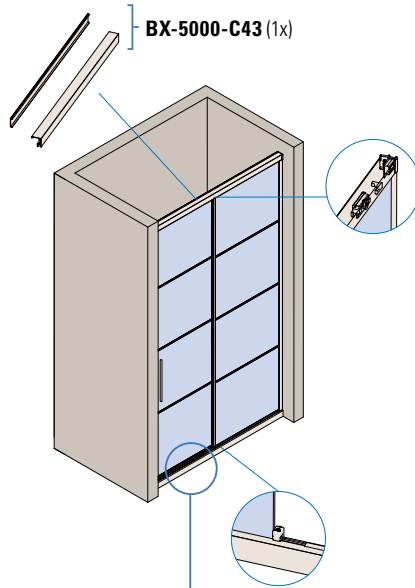

CARATTERISTICHE COMPONENTI
FEATURES COMPONENTS - EIGENSCHAFTEN EINZELTEILE
► 42

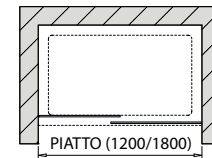
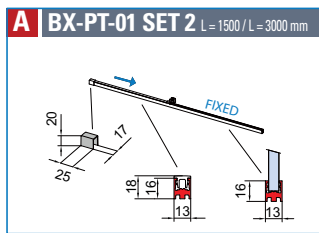

PROFILI A TERRA
FLOOR PROFILES - BODENPROFILE
► 106

xme632e

LAVORAZIONE PROFILI ANTA - PANEL PROFILES PREPARATION - FLÜGELPROFILE BEARBEITUNG

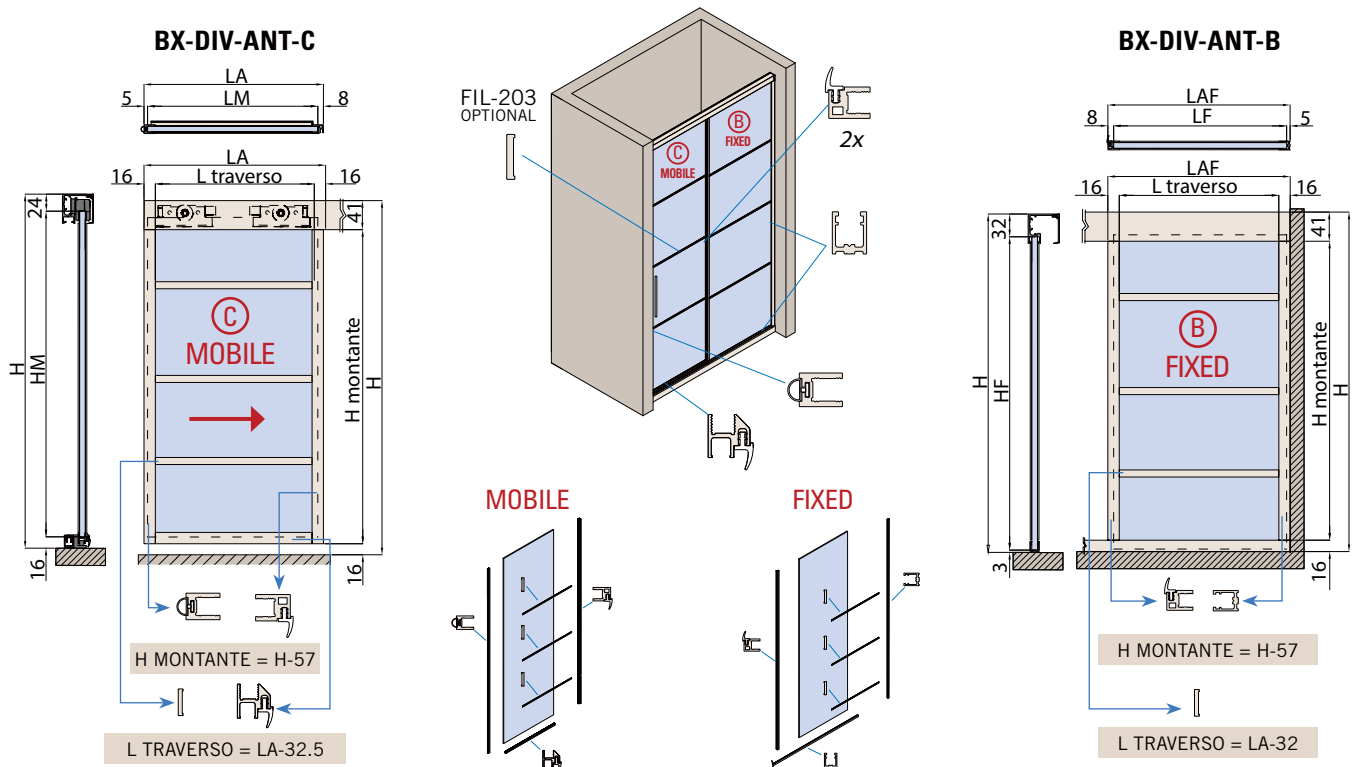

xme632a/xme632b

- | | | | | |
|--|---|--|--|--|
| L
Piatto
Shower tray
Duschtaße | LM
Larghezza vetro mobile
Sliding glass width
Glasbreite-Schiebefügel | LF
Larghezza vetro fisso
Side fixed glass width
Festglasbreite | HM
Altezza vetro mobile
Sliding glass height
Schiebefügel Höhe | HF
Altezza vetro fisso
Side fixed glass height
Glashöhe Festverglasung |
|--|---|--|--|--|

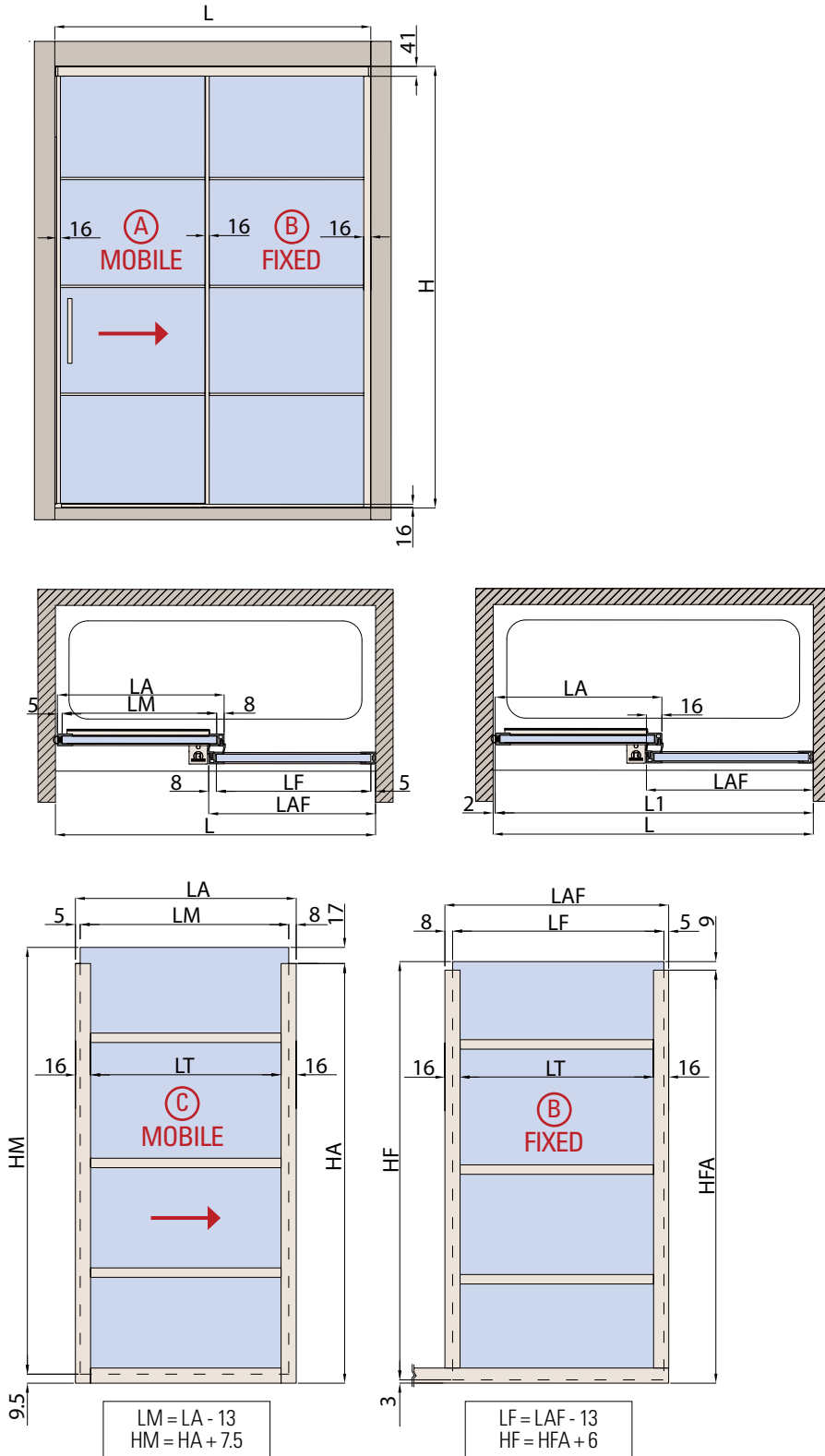
LAVORAZIONE VETRO - GLASS PREPARATION - GLASBEARBEITUNG

CALCOLO VETRO - CALCULATION GLASS - GLASBERECHNUNG

L = PIATTO - SHOWER TRAY - DUSCHTASSE (L)

 $LA = LAF = (L1 + 16) / 2$
 $HA = H - 47$
 $HFA = H - 41$
PROFILI A TERRA - FLOOR PROFILES - BODENPROFILE ▶ 106
A BX-PT-01 STANDARD HF = H - 35 = 1965 mm

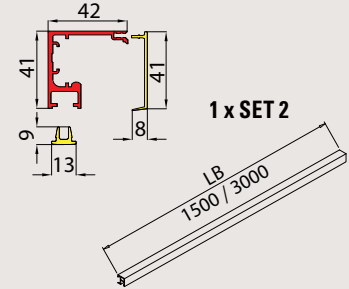
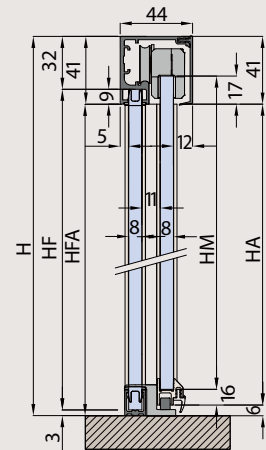
SET 2

 DA TAGLIARE ✂
 ADJUST THE LENGTH
 BELIEBIG KÜRZBAR

 REGOLAZIONE RUOTA ± 2 MM.
 ADJUSTMENT ± 2 MM.
 VERSTELLUNG ± 2 MM.

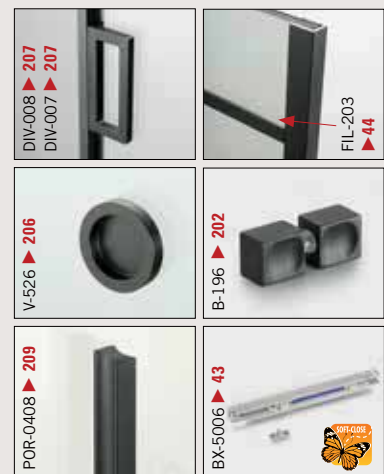
HM = H - 40	HA = H - 47
HF = H - 35	HFA = H - 41

 HF = H - 35
 solo per / only for / nur für
A BX-PT-01
OPTIONAL

xme632i

H
 Altezza doccia
 Shower height
 Duschkabine Höhe

LA
 Larghezza anta mobile
 Sliding door width
 Schiebeflügel Breite

HA
 Altezza profilo verticale anta scorrevole
 Vertical profile height sliding panel
 Vertikalprofil Höhe Schiebeflügel

LAF
 Larghezza anta fissa
 Fixed panel width
 Seitenteil Breite

HFA
 Altezza profilo verticale anta fissa
 Vertical profile height fixed panel
 Vertikalprofil Höhe Seitenteil

BX-DIV5000 SET 3 L = 1500 MM / L = 3000 MM

DOCCIA A U - U SHOWER - U DUSCHE **€ BX.3**

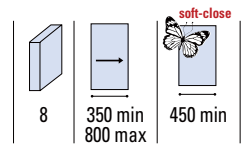

FINITURE - FINISHING - OBERFLÄCHEN: CR - NO - IXE - BI - OR ▶ 22

MY METALGLAS

COMPONENTI - COMPONENTS - EINZELTEILE

- BX-5000-C10** (1x)
- BX-5000-C30** (2x)
- BX-5000-C90 SX** (1x)
BX-5000-C90 DX (1x)
- BX-5000-C81 SX** (1x)
BX-5000-C81 DX (1x)
- BX-DIV-550** (1x)
- BX-5006** (1x) **OPTIONAL SOFT-CLOSE**
- OPTIONAL** (1x)

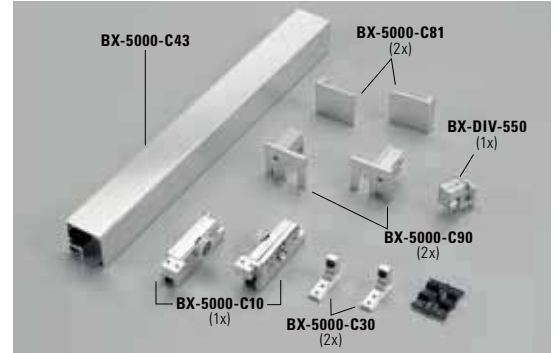
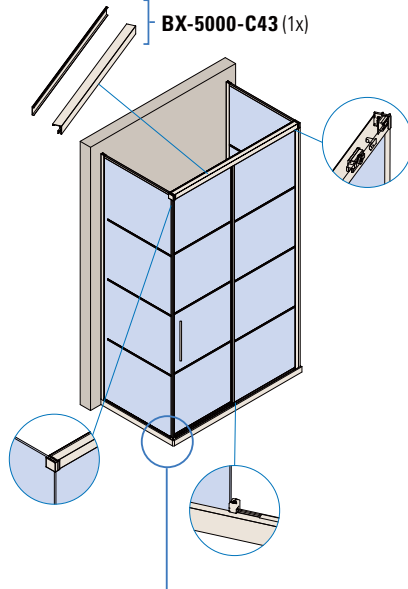

CARATTERISTICHE COMPONENTI
FEATURES COMPONENTS - EIGENSCHAFTEN EINZELTEILE
▶ 42

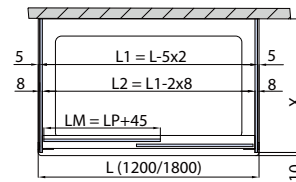
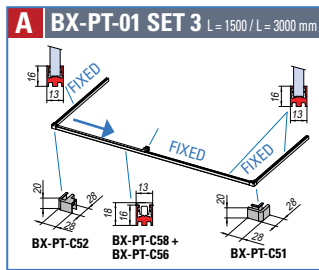

PROFILI A TERRA
FLOOR PROFILES - BODENPROFILE ▶ 106 xme632f

LAVORAZIONE PROFILI ANTA - PANEL PROFILES PREPARATION - FLÜGELPROFILE BEARBEITUNG

BX-DIV-ANT-C

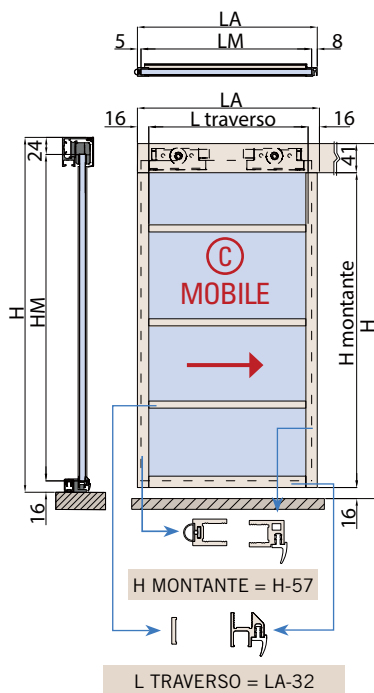

BX-DIV-ANT-B

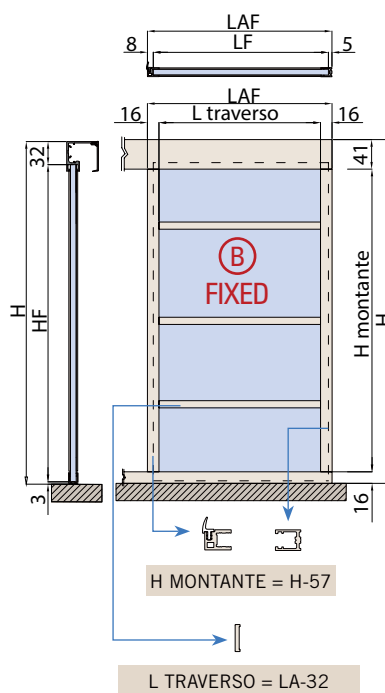

BX-DIV-ANT-D

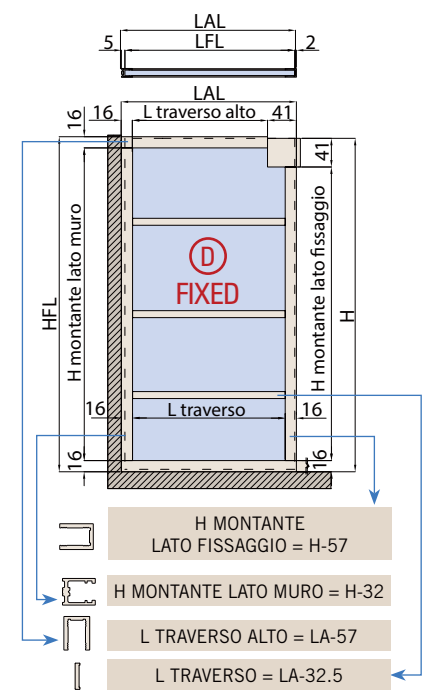

xme632a/xme632b/xme632c

- L**
Piatto
Shower tray
Duschtaße
- LM**
Larghezza vetro mobile
Sliding glass width
Glasbreite-Schiebefügel
- LF / LFL**
Larghezza vetro fisso
Side fixed glass width
Festglasbreite
- HM**
Altezza vetro mobile
Sliding glass height
Schiebefügel Höhe
- HF / HFL**
Altezza vetro fisso
Side fixed glass height
Glashöhe Festverglasung

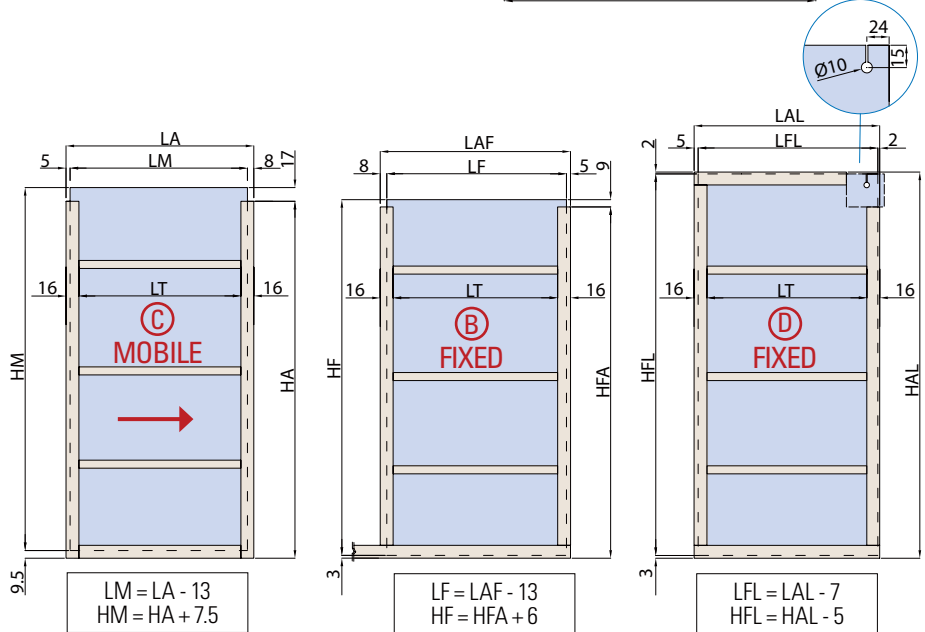
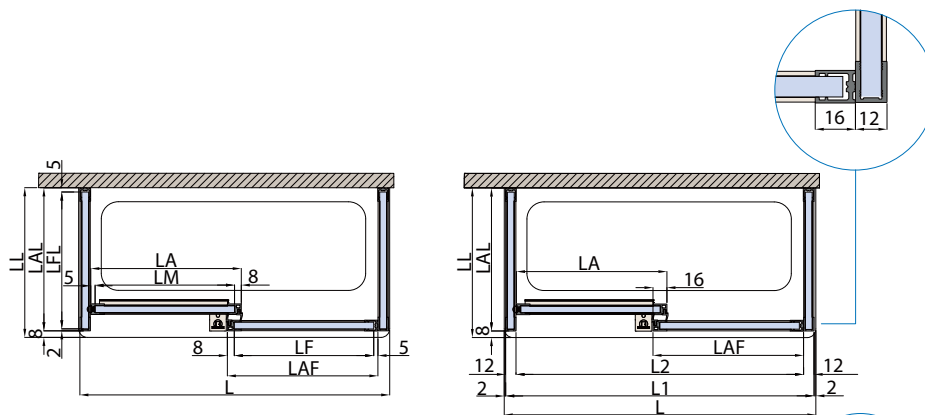
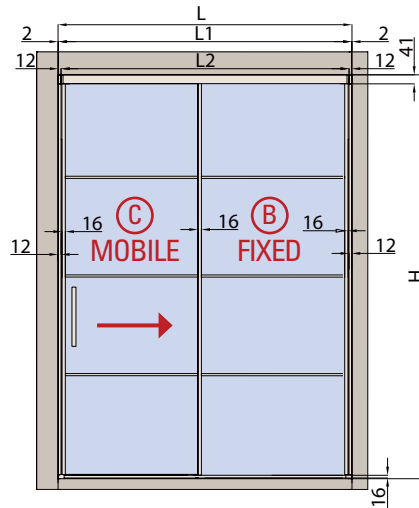
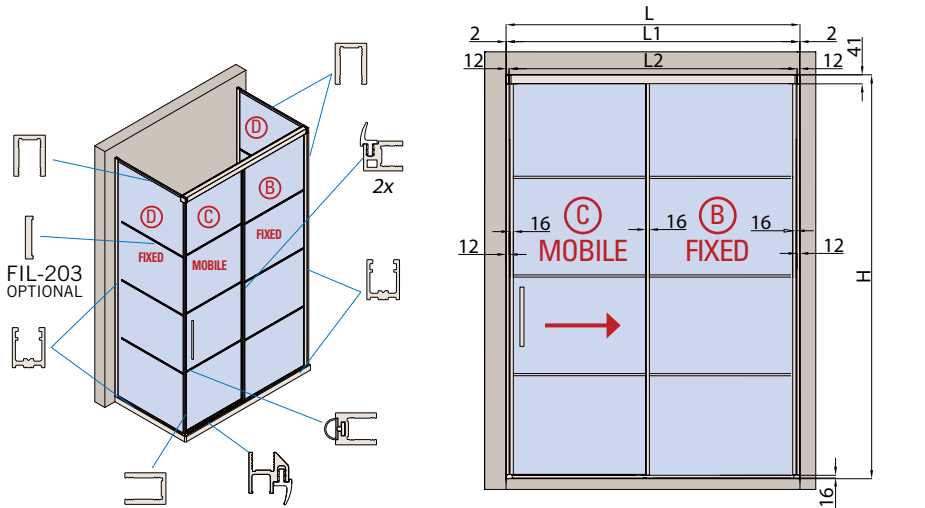
LAVORAZIONE VETRO - GLASS PREPARATION - GLASBEARBEITUNG

CALCOLO VETRO - CALCULATION GLASS - GLASBERECHNUNG

L = PIATTO - SHOWER TRAY - DUSCHTASSE
 $L1 = L - 4$ $HA = H - 47$
 $L2 = L1 - 24$ $HFA = H - 41$
 $LA = LAF = (L2 + 16) / 2$ $HAL = H$
 $LAL = LL - 8$

PROFILI A TERRA - FLOOR PROFILES - BODENPROFILE ▶ 106

A BX-PT-01 STANDARD $HF = H - 35 = 1965$ mm

xme632l

H
Altezza doccia
Shower height
Duschkabine Höhe

LA
Larghezza anta mobile
Sliding door width
Schiebeflügel Breite

HA
Altezza profilo verticale anta scorrevole
Vertical profile height sliding panel
Vertikalprofil Höhe Schiebeflügel

LAF / LAL
Larghezza anta fissa
Fixed panel width
Seitenteil Breite

HFA / HAL
Altezza profilo verticale anta fissa
Vertical profile height fixed panel
Vertikalprofil Höhe Seitenteil

SET 3

DA TAGLIARE ✂
ADJUST THE LENGTH
BELIEBIG KÜRZBAR

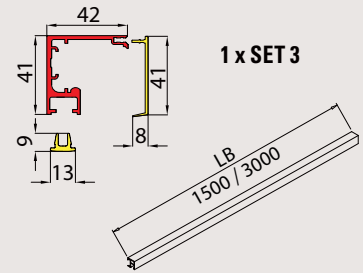

REGOLAZIONE RUOTA ± 2 MM.
ADJUSTMENT ± 2 MM.
VERSTELLUNG ± 2 MM.

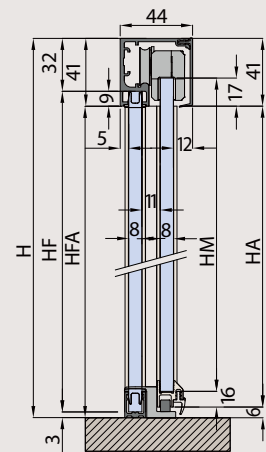

$HM = H - 40$ $HA = H - 47$
 $HF = H - 35$ $HFA = H - 41$

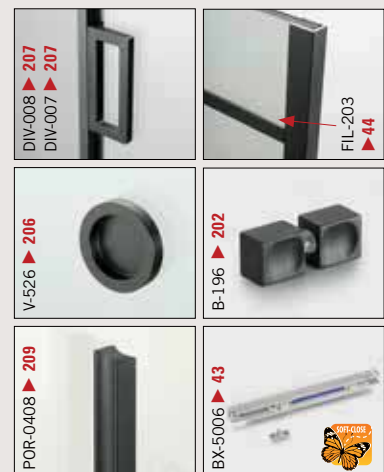
OPTIONAL

SCORREVOLI

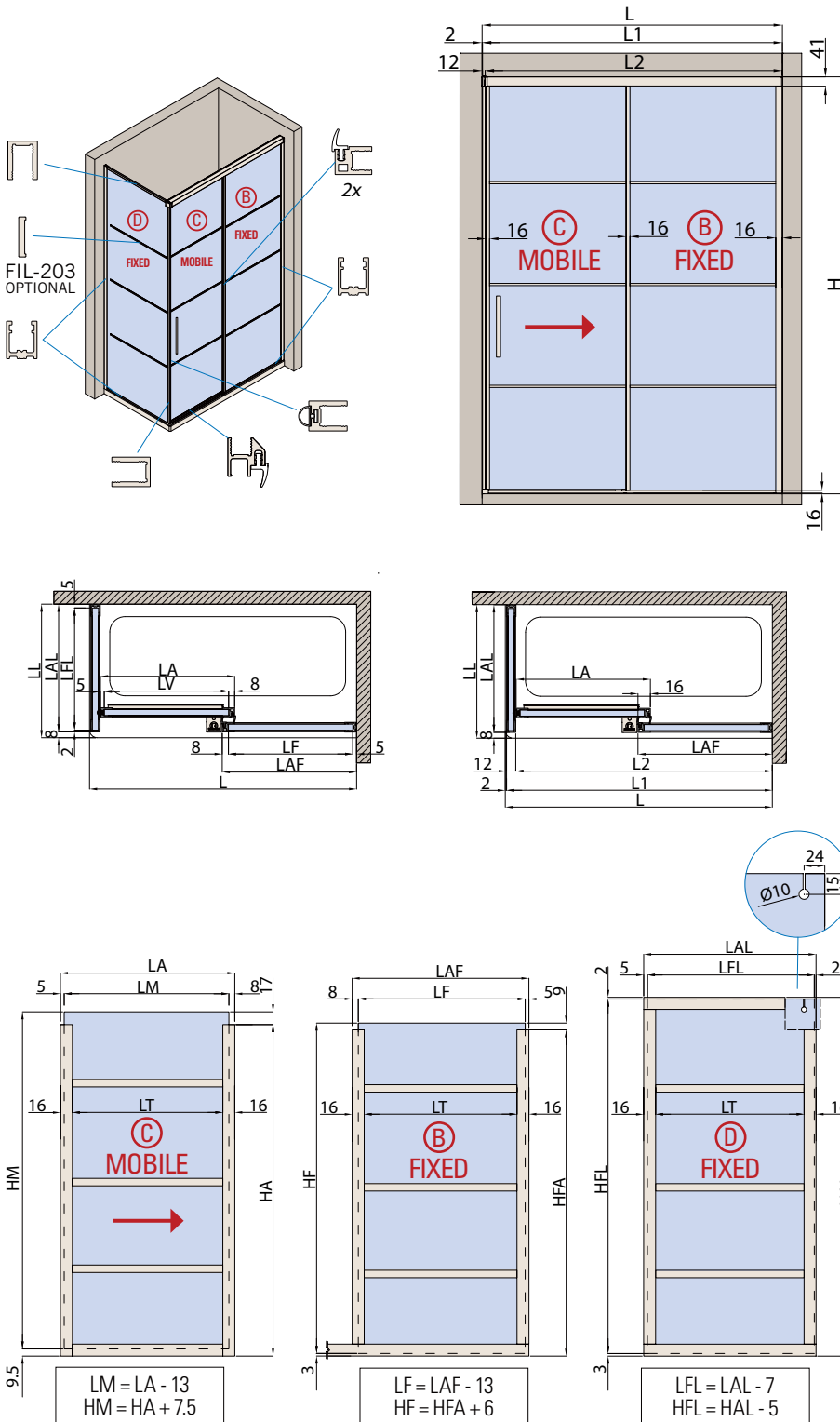
LAVORAZIONE VETRO - GLASS PREPARATION - GLASBEARBEITUNG

CALCOLO VETRO - CALCULATION GLASS - GLASBERECHNUNG

L = PIATTO - SHOWER TRAY - DUSCHTASSE
 L1 = L - 2 HA = H - 47
 L2 = L1 - 12 HFA = H - 41
 LA = LAF = (L2 + 16) / 2 HAL = H
 LAL = LL - 8

PROFILI A TERRA - FLOOR PROFILES - BODENPROFILE ▶ 106

A BX-PT-01 STANDARD HF = H - 35 = 1965 mm

xme632h

H
 Altezza doccia
 Shower height
 Duschkabine Höhe

LA
 Larghezza anta mobile
 Sliding door width
 Schiebeflügel Breite

HA
 Altezza profilo verticale anta scorrevole
 Vertical profile height sliding panel
 Vertikalprofil Höhe Schiebeflügel

LAF
 Larghezza anta fissa
 Fixed panel width
 Seitenteil Breite

HFA
 Altezza profilo verticale anta fissa
 Vertical profile height fixed panel
 Vertikalprofil Höhe Seitenteil

SET 4

DA TAGLIARE ✂
 ADJUST THE LENGTH
 BELIEBIG KÜRZBAR

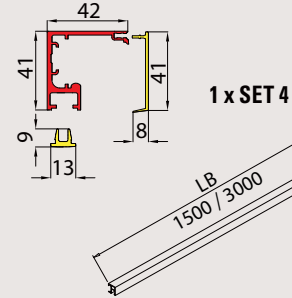

REGOLAZIONE RUOTA ± 2 MM.
 ADJUSTMENT ± 2 MM.
 VERSTELLUNG ± 2 MM.

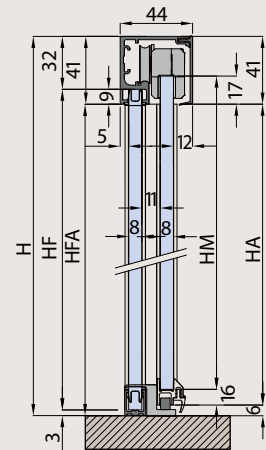

HM = H - 40 HA = H - 47
 HF = H - 35 HFA = H - 41

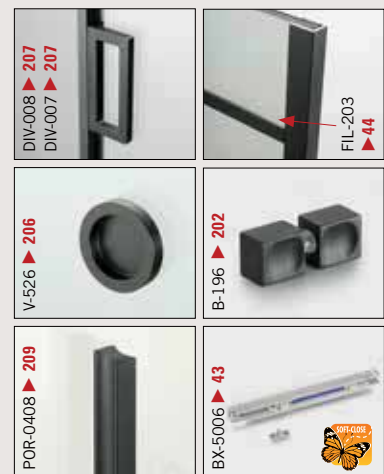
OPTIONAL

SCORREVOLI

BX-DIV5000 SET 5 L = 3000 MM

€ BX.5

DOCCIA CON 2 VETRI FISSI E UNO MOBILE - SHOWER WITH 2 FIXED PANELS AND 1 SLIDING PANEL - DUSCHKABIN MIT 2 SEITENTEILEN UND 1 SCHIEBETÜR

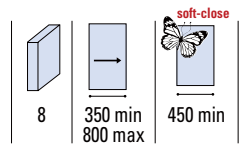

FINITURE - FINISHING - OBERFLÄCHEN: CR - NO - IXE - BI - OR ▶ 22

MY METALGLAS

COMPONENTI - COMPONENTS - EINZELTEILE

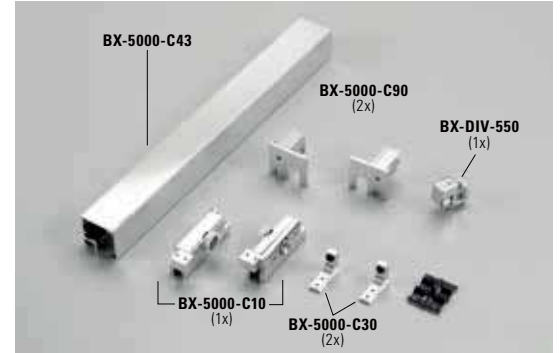
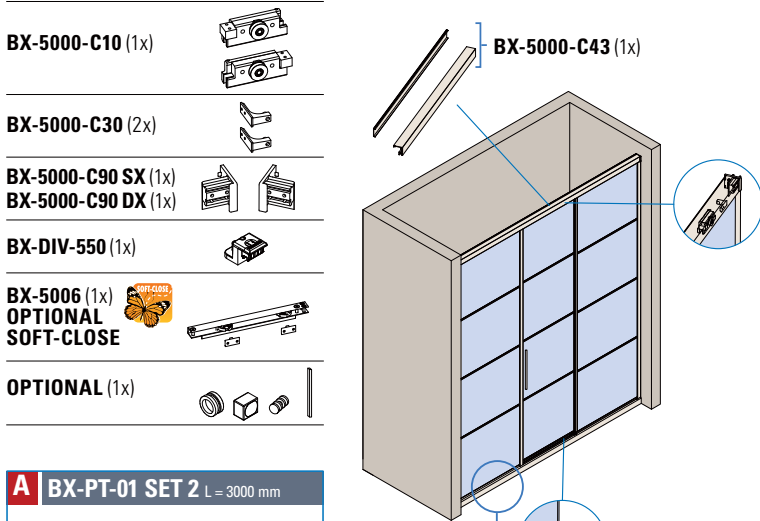

CARATTERISTICHE COMPONENTI
FEATURES COMPONENTS - EIGENSCHAFTEN EINZELTEILE

▶ 42

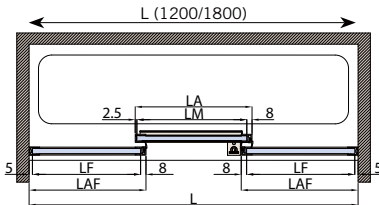
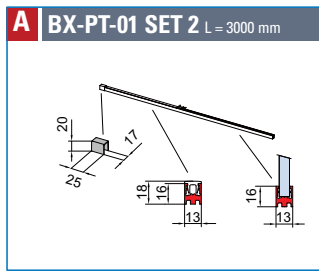

PROFILI A TERRA
FLOOR PROFILES - BODENPROFILE

▶ 106

xme632r

LAVORAZIONE PROFILI ANTA - PANEL PROFILES PREPARATION - FLÜGELPROFILE BEARBEITUNG

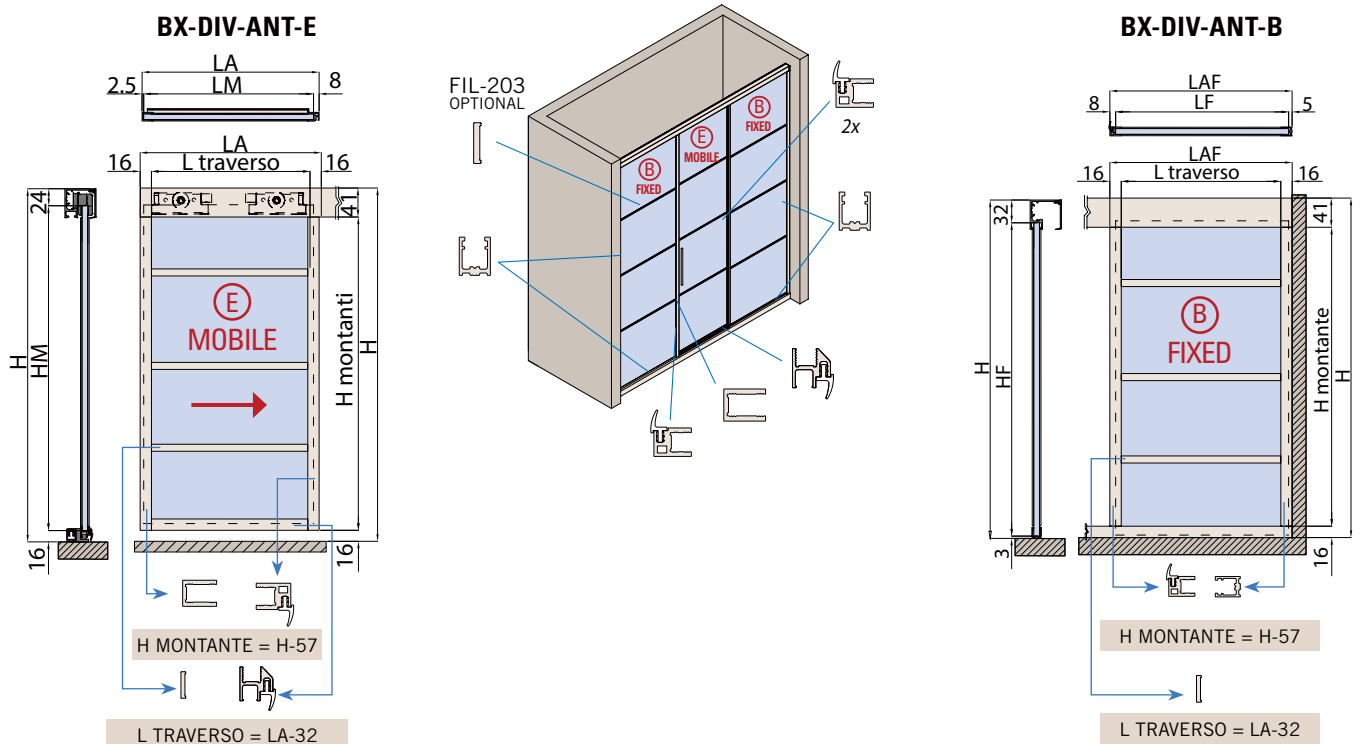

xme632a/xme632r

L Piatto Shower tray Duschtaße	LM Larghezza vetro mobile Sliding glass width Glasbreite-Schiebeflügel	LF Larghezza vetro fisso Side fixed glass width Festglasbreite	HM Altezza vetro mobile Sliding glass height Schiebeflügel Höhe	HF Altezza vetro fisso Side fixed glass height Glashöhe Festverglasung
--	--	--	---	--

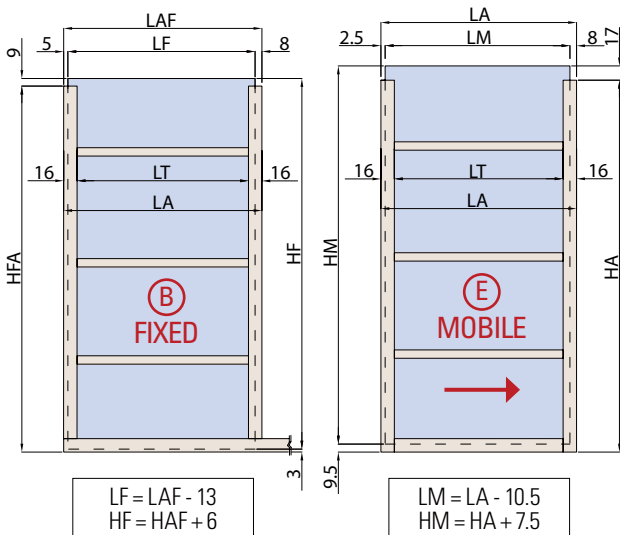
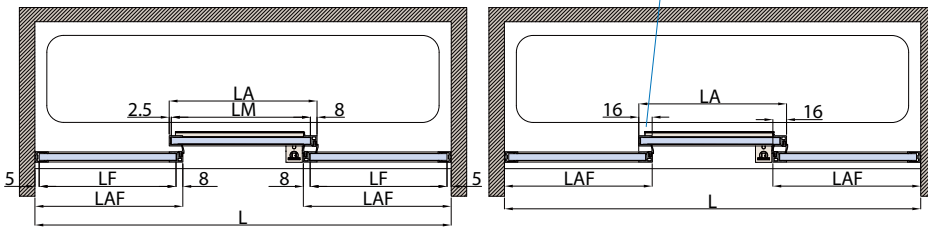
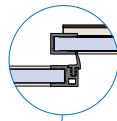
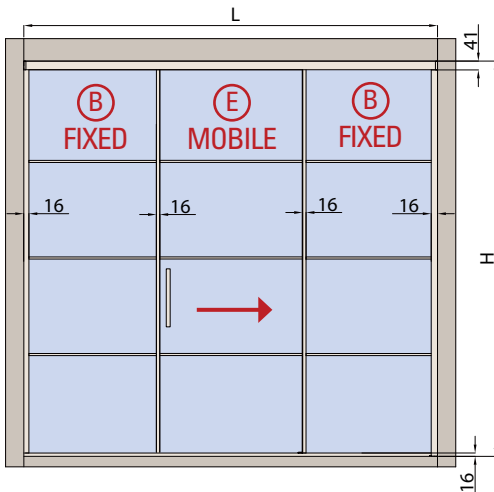
LAVORAZIONE VETRO - GLASS PREPARATION - GLASBEARBEITUNG

CALCOLO VETRO - CALCULATION GLASS - GLASBERECHNUNG

L = PIATTO - SHOWER TRAY - DUSCHTASSE

 $LA = LAF = (L + 32) / 3$
 $HA = H - 47$
 $HFA = H - 41$
PROFILI A TERRA - FLOOR PROFILES - BODENPROFILE ▶ 106
A BX-PT-01 STANDARD HF = H - 35 = 1965 mm

H
 Altezza doccia
 Shower height
 Duschkabine Höhe

LA
 Larghezza anta mobile
 Sliding door width
 Schiebeflügel Breite

HA
 Altezza profilo verticale anta scorrevole
 Vertical profile height sliding panel
 Vertikalprofil Höhe Schiebeflügel

LAF
 Larghezza anta fissa
 Fixed panel width
 Seitenteil Breite

HFA
 Altezza profilo verticale anta fissa
 Vertical profile height fixed panel
 Vertikalprofil Höhe Seitenteil

SET 5

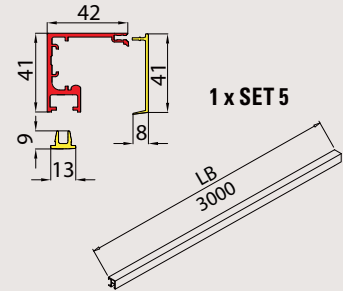
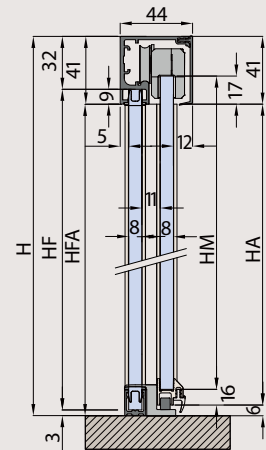
 DA TAGLIARE ✂
 ADJUST THE LENGTH
 BELIEBIG KÜRZBAR

 REGOLAZIONE RUOTA ± 2 MM.
 ADJUSTMENT ± 2 MM.
 VERSTELLUNG ± 2 MM.

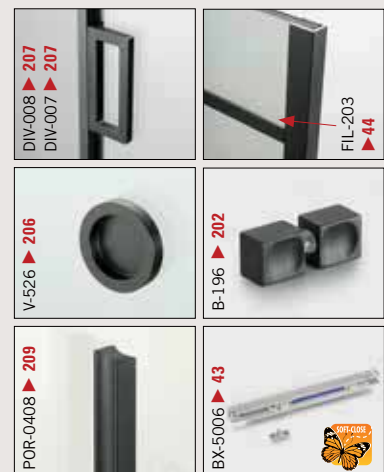
HM = H - 40	HA = H - 47
HF = H - 35	HFA = H - 41

OPTIONAL

xme632q

SCORREVOLI

BX-DIV5000 SET 6 L = 3000 MM

€ BX.6

DOCCIA CON 2 VETRI FISSI E 2 MOBILI - SHOWER WITH 2 FIXED PANELS AND 2 SLIDING PANELS - DUSCHKABIN MIT 2 SEITENTEILEN UND 2 SCHIEBETÜREN

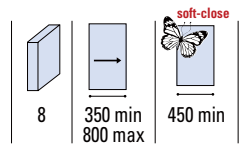

FINITURE - FINISHING - OBERFLÄCHEN: CR - NO - IXE - BI - OR ▶ 22

MY METALGLAS

COMPONENTI - COMPONENTS - EINZELTEILE

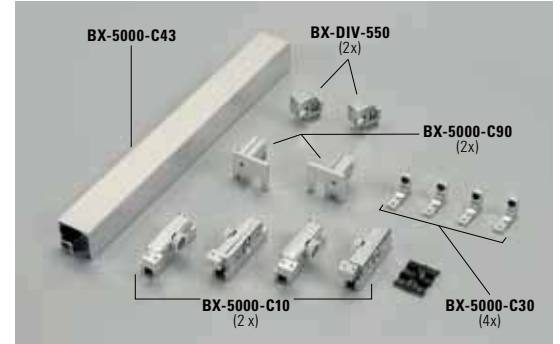
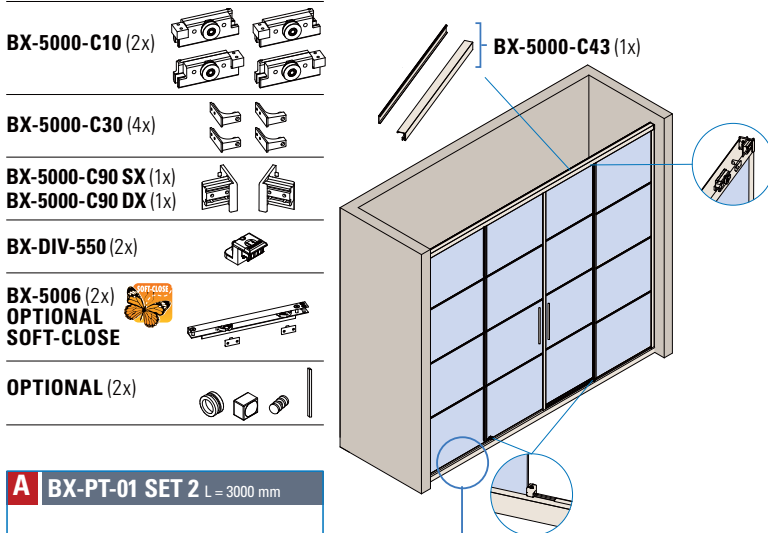

CARATTERISTICHE COMPONENTI
FEATURES COMPONENTS - EIGENSCHAFTEN EINZELTEILE
▶ 42

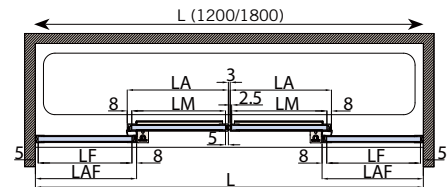
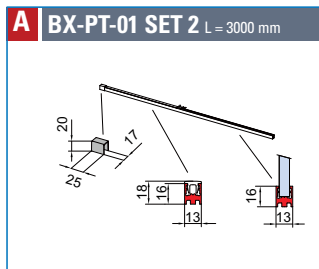

PROFILI A TERRA
FLOOR PROFILES - BODENPROFILE
▶ 106

xme632t

LAVORAZIONE PROFILI ANTA - PANEL PROFILES PREPARATION - FLÜGELPROFILE BEARBEITUNG

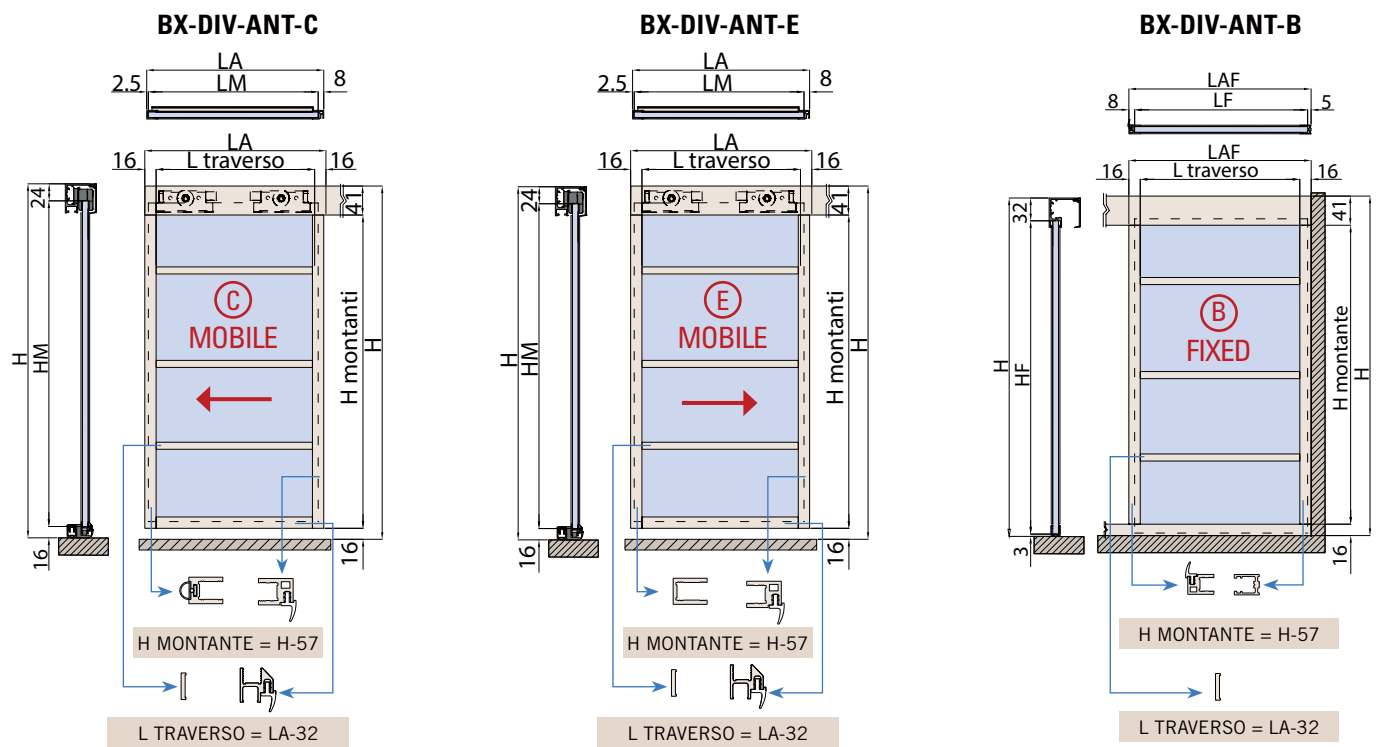

xme632a/xme632t

L Piatto Shower tray Duschtaße	LM Larghezza vetro mobile Sliding glass width Glasbreite-Schiebeflügel	LF Larghezza vetro fisso Side fixed glass width Festglasbreite	HM Altezza vetro mobile Sliding glass height Schiebeflügel Höhe	HF Altezza vetro fisso Side fixed glass height Glashöhe Festverglasung
--	--	--	---	--

BX-DIV5000

COMPONENTI - COMPONENTS - EINZELTEILE

SCORREVOLI

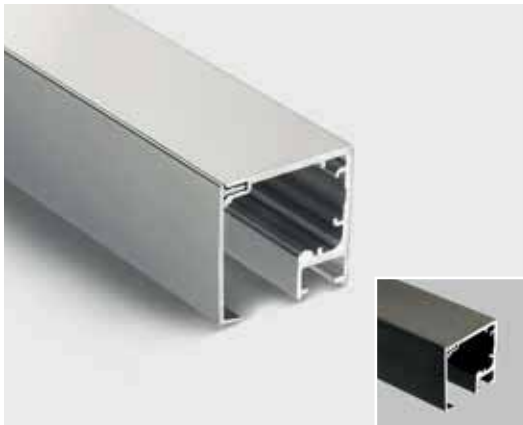

BX-5000-C40/C43

- Binario con veletta, profilo di chiusura per sede vetro fisso BX-4001 incluso
- Track profile with cover, profile for fixed glass section BX-4001 included
- Laufschiene mit Profilabdeckung, Sichtschutzprofil für Seitenteil Sektor BX-4001 enthalten

CR - NO - IXE - BI - OR

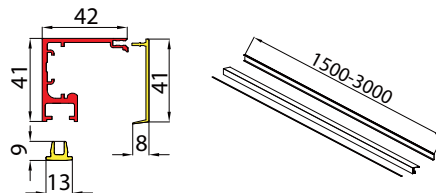

Cod.	Fin. / Fin. / Oberf.
BX-5000-C43-1500 mm	CR / NO / IXE / BI / OR
BX-5000-C43-3000 mm	CR / NO / IXE / BI / OR
BX-5000-C40-1000 x 1000 mm (2 pcs)	CR / NO / IXE / BI / OR

€► BX.7

xme632n



BX-5000-C10

- Set composto da 2 carrelli (1 pc DX + 1 pc SX)
- Set consisting of 2 roller carriers (1 pc right + 1 pc left)
- Set bestehend aus 2 Klemm-Laufwagen (1 Stk Rechts + 1 Stk Links)

CR - NO

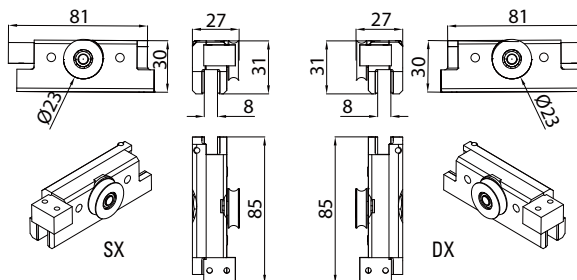

€► BX.8

xme632n



BX-5000-C30

- Stopper

CR - NO

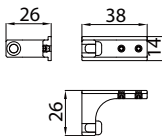

€► BX.8.1

xme632n



BX-5000-C90 DX

- Attacco a parete destro per binario
- Right wall connector for track profile
- Wandhalter rechts für Laufschiene

CR - NO - NS - BI - OR

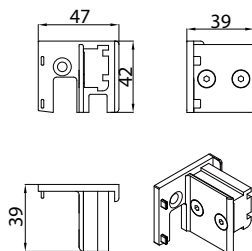

€► BX.9

xme632n



BX-5000-C90 SX

- Attacco a parete sinistro per binario
- Left wall connector for track profile
- Wandhalter links für Laufschiene

CR - NO - NS - BI - OR

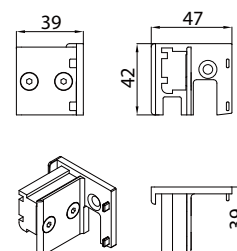

€► BX.10

xme632n

BX-5000-C81 DX

- Piastrina destra attacco a vetro per BX-5000-C90
 - Right plate glass connector for BX-5000-C90
 - Platte Glashalter rechts für BX-5000-C90
- CR - NO - NS - BI - OR

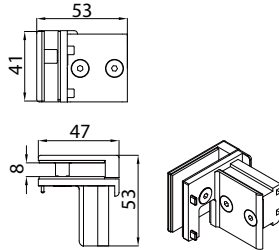
BX.11

xme632n

BX-5000-C81 SX

- Piastrina sinistra attacco a vetro per BX-5000-C90
 - Left plate glass connector for BX-5000-C90
 - Platte Glashalter links für BX-5000-C90
- CR - NO - NS - BI - OR

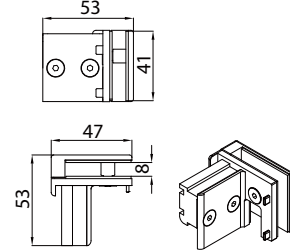
BX.12

xme632n

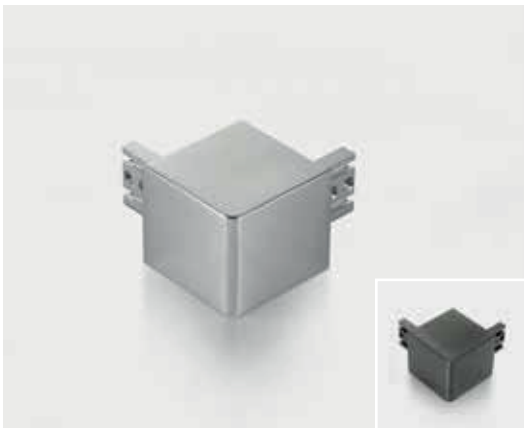
BX-5000-C20

- Connettore ad angolo per binario per set 1
 - Corner connector for track profile set 1
 - Winkelverbinder Laufschiene set 1
- CR - NO - NS - BI - OR

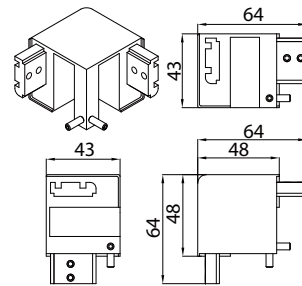
BX.13

xme632n

BX-DIV-550

- Guida per anta intelaiata per applicazione con profilo a terra BX-PT-C58 sistema di sgancio della porta per facilitare la pulizia
 - Floor guide for framed panel for installation with floor profile BX-PT-C58 with quick release door function for easy cleaning
 - Gerahmte Tür Bodenführung für Montage mit Bodenprofil BX-PT-C58 mit auslosbarem System um das Reinigen zu erleichtern
- CR - NO - NS - BI - OR

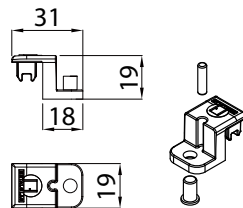
BX.14

xme632n

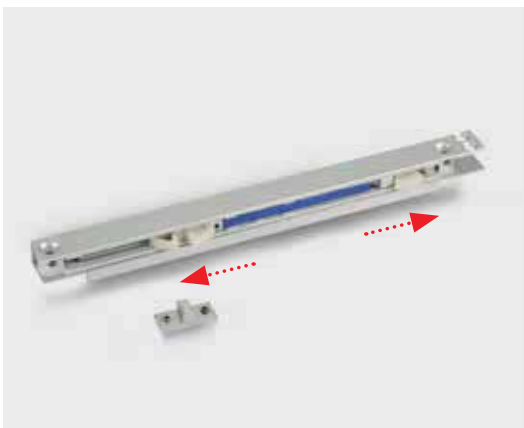
BX-5006 Optional SOFT-CLOSE

- Soft-close in apertura e chiusura
- Double acting Soft-close
- Soft-close doppelt Winkende

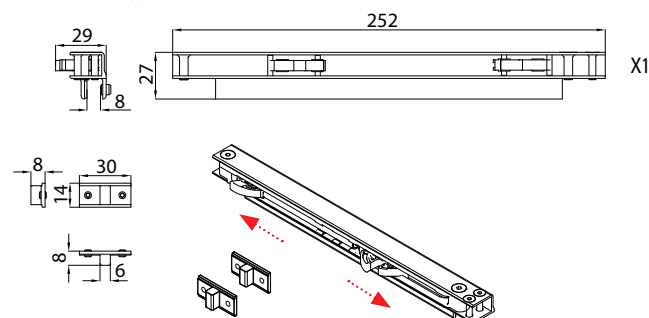
BX.15

xme632n

BX-DIV5000

PROFILI ANTE - PANEL PROFILES - FLÜGELPROFILE

SCORREVOLI



BX-DIV-502

- Profilo bordo vetro (componente anta D - E)
- Frame profile (component panel D - E)
- Rahmenprofil (Einzelteil Flügel D - E)

L = 3000 mm / L = 1000 mm
CR - NO - IXE - BI - OR

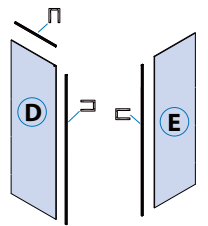
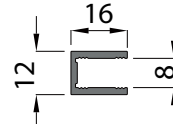
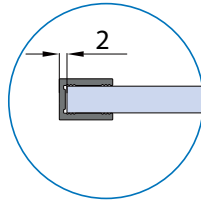

€► BX.16

xme632o

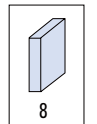

BX-DIV-526

- Profilo bordo vetro con guarnizione aletta laterale (componente anta A - B - C - E)
- Frame profile, gasket with side fin included (component panel A - B - C - E)
- Rahmenprofil mit Schiebetürdichtprofil (Einzelteil Flügel A - B - C - E)

L = 3000 mm
CR - NO - IXE - BI - OR

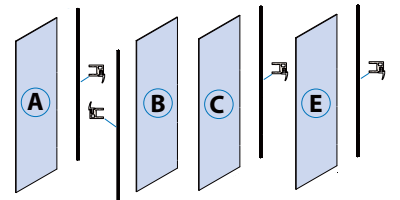
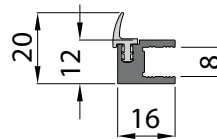
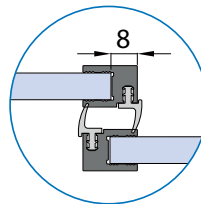

€► BX.17

xme632o

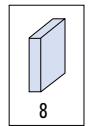

BX-DIV-527

- Profilo bordo vetro con guarnizione a palloncino (componente anta C)
- Frame profile with balloon gasket (component panel C)
- Rahmenprofil mit Dichtung (Einzelteil Flügel C)

L = 3000 mm
CR - NO - IXE - BI - OR

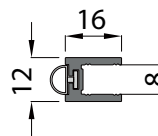
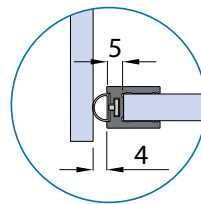

€► BX.18

xme632o

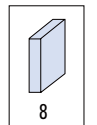
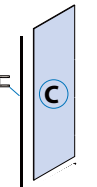

BX-DIV-543

- Paio profili bordo vetro con guarnizione magnetica per chiusura 90° (componente anta A)
- Pair frame profiles with 90° magnetic gaskets (component panel A)
- Paar Rahmenprofile mit 90° Magnetsdichtungen (Einzelteil Flügel D - E)

L = 3000 mm
CR - NO - IXE - BI - OR

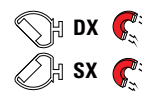
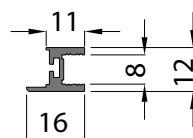
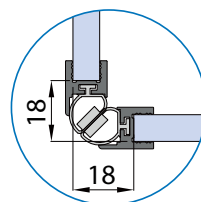

€► BX.19

xme632o

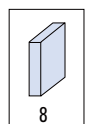
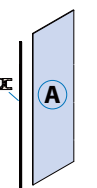



BX-DIV-519

- Profilo inferiore con guarnizione gocciolatoio (componente anta A - C - E)
- Bottom profile with drip flap seal gasket (component panel A - C - E)
- Rahmenprofil mit Lippe für den unteren Wannenanschluss (Einzelteil Flügel A - C - E)

L = 3000 mm / L = 1000 mm

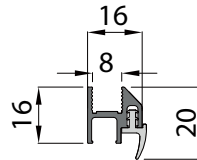
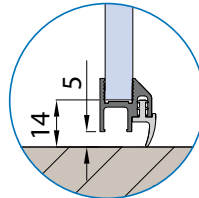
CR - NO - IXE - BI - OR



€► BX.20

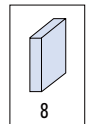
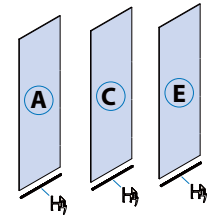

xme632o

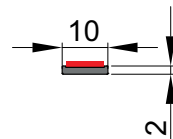

FIL-203

- Optional traverso
- Cross profile
- Querprofil

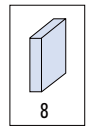

■ Biadesivo preinstallato
 Pre-installed
 double-sided adhesive
 Selbstklebend

€► BX.21



xme595m

BX-PT-C58

- Profilo per fissaggio a terra o laterale
- Profile for floor and side installation
- Profil Boden- Wandmontage

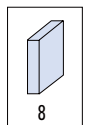
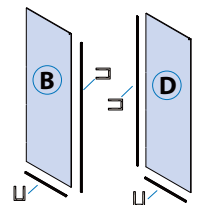
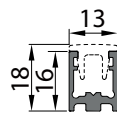

€► BX.144

Cod.	Fin./Fin./Fin.
BX-PT-C58-1500 mm	CR - NO - IXE - BI - OR
BX-PT-C58-3000 mm	CR - NO - IXE - BI - OR

BX-PT-C56

- Coperchio per profilo a terra per tratto entrata doccia
- Cover profile for floor profile, shower entry.
- Profilabdeckung Bodenprofil Duscheinstieg

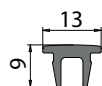

€► BX.145

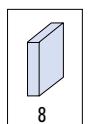

Cod.	Fin./Fin./Fin.
BX-PT-C56-1500 mm	CR - NO - IXE - BI - OR
BX-PT-C56-3000 mm	CR - NO - IXE - BI - OR

Con i profili bordatura e listelli Filo diventa molto semplice trasformare vetri fissi in séparé di carattere e design.

Thanks to Filo edging and cross profiles, transforming fixed glass into design partitions with character becomes effortless.

Mit den Filo-Einfassprofilen und -Leisten wird es sehr einfach, Festverglasungen in ein Séparée mit Charakter und Design zu verwandeln.



SCORREVOLI

BX-DIV-502



FIL-203



BX-PF-02



B-328





BX-PF-02
PROFILO A PARETE
WALL PROFILE
WANDANSCHLUSSPROFIL

B-328-F
BARRA DI SUPPORTO
SUPPORT BAR
STABILISATIONSSTANGE

BOX DOCCIA - SHOWER BOX - DUSCHKABINE
SEPARÉ
WALK-IN SYSTEM
WALK-IN SYSTEM

BX-DIV-502
PROFILO PERIMETRALE
FRAME PROFILE
RAHMENPROFIL

FIL-203
LISTELLO
CROSS PROFILE
QUERPROFIL

NO
FINITURA
FINISHING
OBERFLÄCHE



BX-5000 TINY

LA DOCCIA INVISIBILE

BX-5000 è il sistema per box doccia semplice e veloce.
 Semplice e veloce nel montaggio grazie all'assenza di lavorazioni nel vetro.
 Semplice e veloce da pulire con la possibilità di sgancio nella guida inferiore.

FUNZIONALITÀ PERFETTA E GRANDE IMPATTO ESTETICO.

- THE INVISIBLE SHOWER ENCLOSURE
- BX-5000 is a sliding shower enclosure without glass preparation and with optional soft-close closing system, easy and quickly to install. Release door function for easy cleaning.
- FUNCTIONALITY MEETS DESIGN.
- Unsichtbare Duschkabine
- Bx-5000, die Duschkabine ohne Glasbearbeitung, mit optionalem Dämpfung System, einfache und schnelle Montage. Die auslösbare Bodenführung erleichtert das Reinigen.
- Funktionalität trifft auf Design.



PLUS

- BINARIO ALTO SOLO 40 MM
- MINIMAL E SEMPLICE DA MONTARE
- PINZE REGOLABILI IN ALTEZZA +/- 2,5 MM
- VETRO FISSO INGLOBATO NEL BINARIO
- POSSIBILITÀ DI SOFT-CLOSE SIA IN APERTURA CHE IN CHIUSURA
- DISTANZA TRA VETRO FISSO E MOBILE DI 11 MM
- POSSIBILITÀ DI SGANCIARE LA GUIDA INFERIORE PER UNA PERFETTA PULIZIA

- Rail only 40 mm high
- Minimal and easy to assemble
- Adjustable clamp height +/- 2,5 mm
- Fixed glass enclosed in the rail
- Possible soft-close in both opening and closure
- Only 11mm gap between panels
- Quick release door function for easy cleaning

- Schienenhöhe nur 40 mm
- Einfach und leicht zu montieren
- Höhenverstellbare Laufwagen +/- 2,5 mm
- Festes Glas in die Schiene eingebaut
- Soft-close beidseitig beim öffnen und schließen möglich
- Nur 11 mm Abstand zwischen den Glasscheiben
- Die auslösbare Bodenführung erleichtert das Reinigen

BX-5000 TINY (OPTIONAL SOFT-CLOSE)

NEW



SCORREVOLI



- Sistema scorrevole per box doccia disponibile per versioni in angolo, lineare e in nicchia.
Possibilità di regolazione tramite ruota $\pm 2,5$ mm. Optional soft-close
- Sliding system for shower box, available for corners, single doors or for niche installations. Adjustment of carrying wheels $\pm 2,5$ mm. Optional soft-close
- Schiebetürsystem für Duschkabine, lieferbar für Eck-, Linear und Nischenduschen. Höheneinstellung der Räder $\pm 2,5$ mm. Optional soft-close



SCORREVOLI

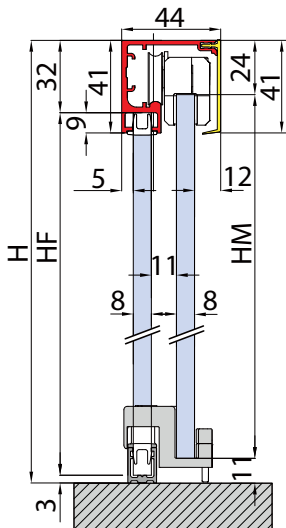

 SET 1 €►BX.28
 €KIT►BX.2

 SET 2 €►BX.29
 €KIT►BX.23

 SET 3 €►BX.30
 €KIT►BX.24

 SET 4 €►BX.31
 €KIT►BX.25

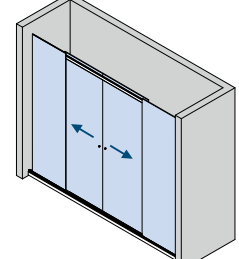
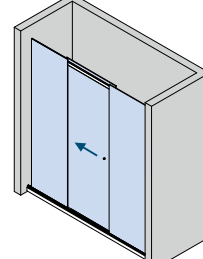
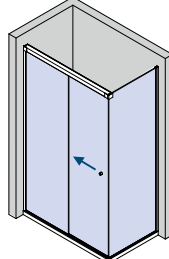
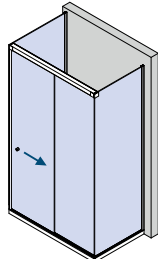
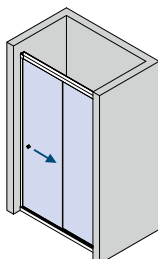
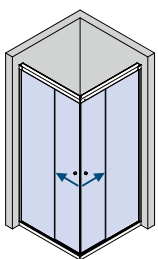
 SET 5 €►BX.32
 €KIT►BX.26

 SET 6 €►BX.33
 €KIT►BX.27

BX-5000 SET 1

L = 1000 x 1000 mm

DOCCIA IN ANGOLO / CORNER SHOWER / ECKDUSCHE

MY METALGLAS

€ ▶ BX.28

€ KIT ▶ BX.22

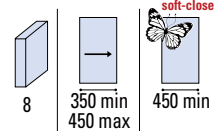

FINITURE
FINISHING - OBERFLÄCHEN:
CR - NO - IXE - BI - OR ▶ 22

COMPONENTI / COMPONENTS / EINZELTEILE

- BX-5000-C10** (2x)
- BX-5000-C30** (4x)
- BX-5000-C90 SX** (1x)
BX-5000-C90 DX (1x)
- BX-5000-C20** (1x)
- BX-3150** (2x)
- BX-5006** (2x) **OPTIONAL SOFT-CLOSE**
- OPTIONAL** (1x)

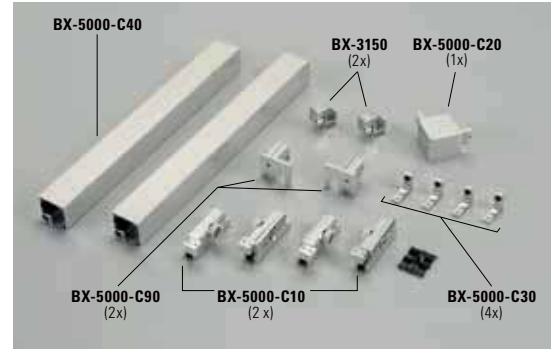
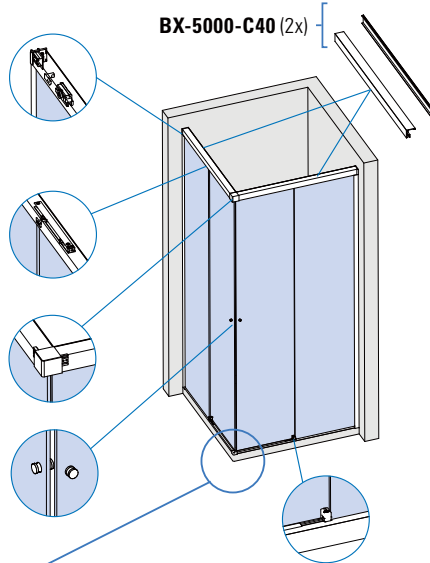

CARATTERISTICHE COMPONENTI /
FEATURES COMPONENTS /
EIGENSCHAFTEN EINZELTEILE ▶ 58

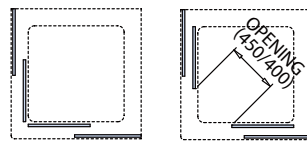
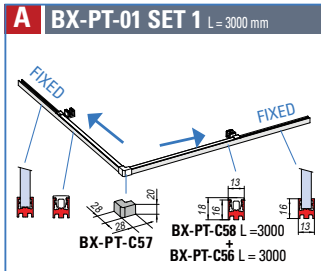

PROFILI A TERRA / FLOOR PROFILES / BODENPROFILE ▶ 106

xme628a

BX-5000 SET 2

L = 1500 mm / L = 3000 mm

DOCCIA IN NICCHIA / NICHE SHOWER / NISCHENDUSCHE

MY METALGLAS

€ ▶ BX.29

€ KIT ▶ BX.23

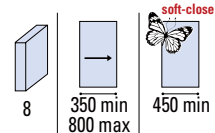

FINITURE
FINISHING - OBERFLÄCHEN:
CR - NO - IXE - BI - OR ▶ 22

COMPONENTI / COMPONENTS / EINZELTEILE

- BX-5000-C10** (1x)
- BX-5000-C30** (2x)
- BX-5000-C90 SX** (1x)
BX-5000-C90 DX (1x)
- BX-3150** (1x)
- BX-5006** (1x) **OPTIONAL SOFT-CLOSE**
- OPTIONAL** (1x)

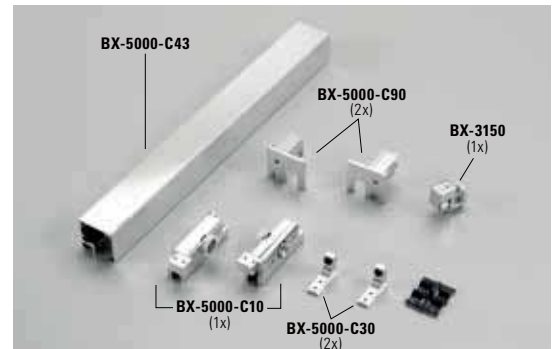
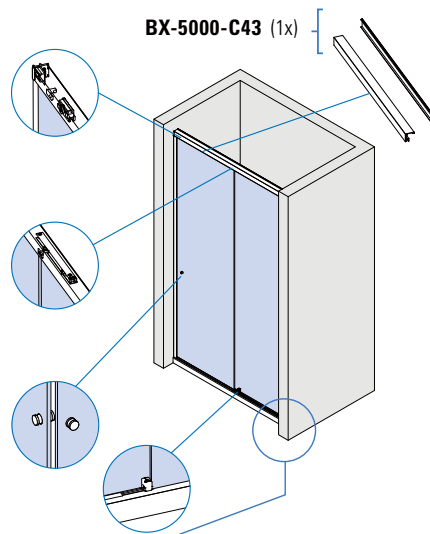

CARATTERISTICHE COMPONENTI /
FEATURES COMPONENTS /
EIGENSCHAFTEN EINZELTEILE ▶ 58

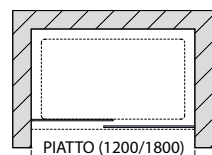
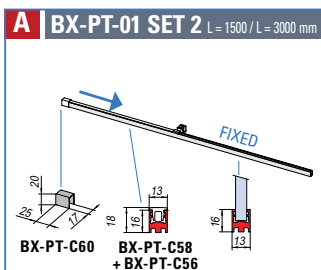

PROFILI A TERRA / FLOOR PROFILES / BODENPROFILE ▶ 106

xme628a

LAVORAZIONE VETRO / GLASS PREPARATION / GLASBEARBEITUNG

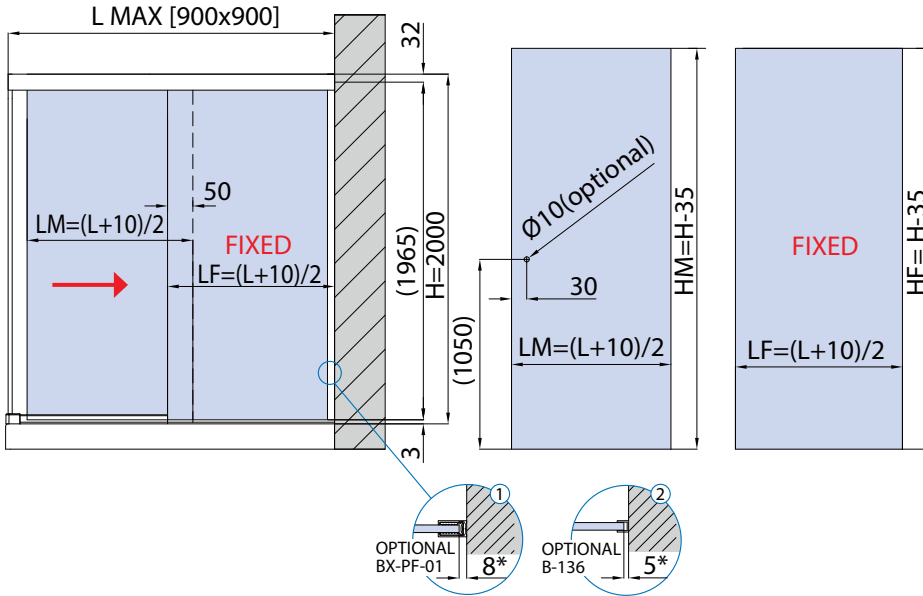

CALCOLO VETRO / CALCULATION GLASS / GLASBERECHNUNG

PIATTO - SHOWER TRAY - DUSCHTASSE (L max) = 900 x 900 mm

$$LM = (L+10) / 2$$

$$LF = (L+10) / 2 - * \textcircled{1} / * \textcircled{2} \text{ (aria variabile / clearance / Spaltmaß)}$$

$$HM = H - 35 \text{ (1965)}$$

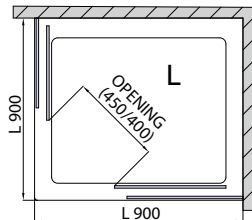

xme628b

PROFILI A TERRA / FLOOR PROFILES / BODENPROFILE ▶ 106

A BX-PT-01 STANDARD HF = H - 35 = 1965 mm

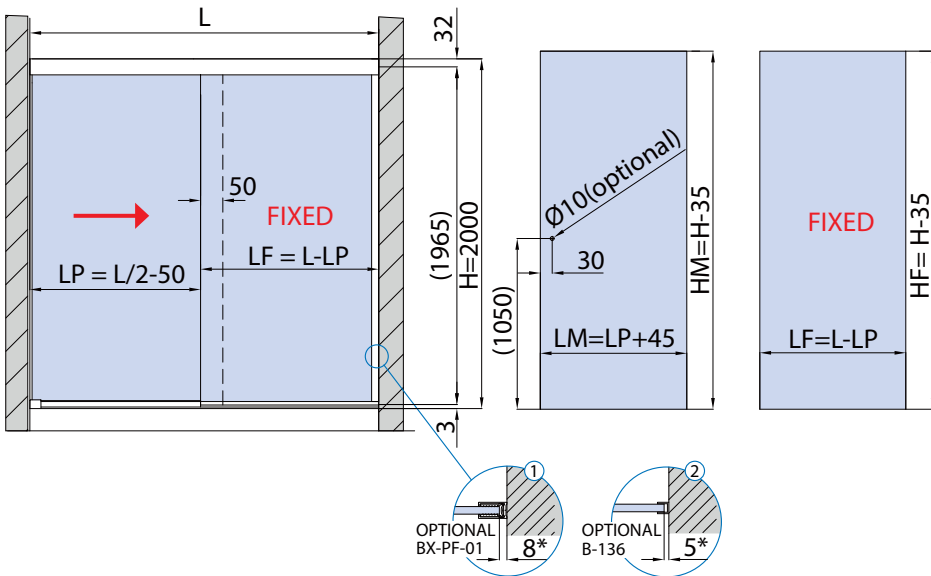

CALCOLO VETRO / CALCULATION GLASS / GLASBERECHNUNG

L = PIATTO - SHOWER TRAY - DUSCHTASSE

$$LP = L / 2 - 50$$

$$LM = LP + 45$$

$$LF = L - LP - * \textcircled{1} / * \textcircled{2} \text{ (aria variabile / clearance / Spaltmaß)}$$

$$HM = H - 35 \text{ (1965)}$$

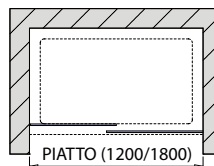

xme628b

L
Piatto
Shower tray
Duschtaße

LP
Passaggio luce
Clear opening width
Lichte Durchgangsbreite

LM
Larghezza vetro mobile
Sliding glass width
Schiebeflügel Breite

LF
Larghezza vetro fisso
Side fixed glass width
Seitenteil Breite

HM
Altezza vetro mobile
Sliding glass height
Schiebeflügel Höhe

HF
Altezza vetro fisso
Side fixed glass height
Seitenteil Höhe

H
Altezza doccia
Shower height
Duschkabine Höhe

SET 1 / SET 2

DA TAGLIARE / ADJUST THE LENGTH / BELIEBIG KÜRZBAR ✂

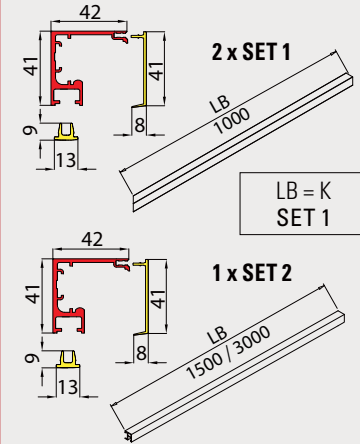

- Regolazione ruota ± 2,5 mm.
- Adjustment ± 2,5 mm.
- Verstellung ± 2,5 mm.

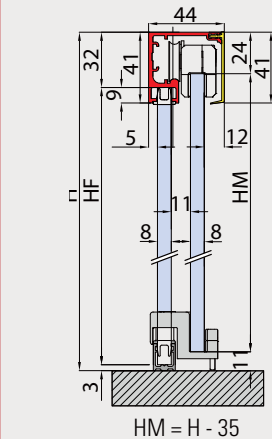

HF = H - 35
solo per / only for / nur für
A BX-PT-01

OPTIONAL



SCORREVOLI

BX-5000 SET 3

L = 1500 mm / L = 3000 mm
DOCCIA A U / U SHOWER / U DUSCHE

MY METALGLAS

€> BX.30

€KIT > BX.24

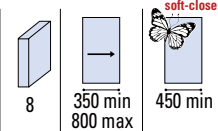

FINITURE
FINISHING - OBERFLÄCHEN:
CR - NO - IXE - BI - OR ▶ 22

COMPONENTI / COMPONENTS / EINZELTEILE

BX-5000-C10 (1x)

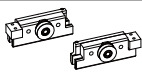

BX-5000-C30 (2x)



BX-5000-C90 SX (1x)



BX-5000-C90 DX (1x)



BX-5000-C81 SX (1x)



BX-5000-C81 DX (1x)



BX-3150 (1x)



BX-5006 (1x)



OPTIONAL
SOFT-CLOSE

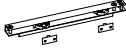

OPTIONAL (1x)

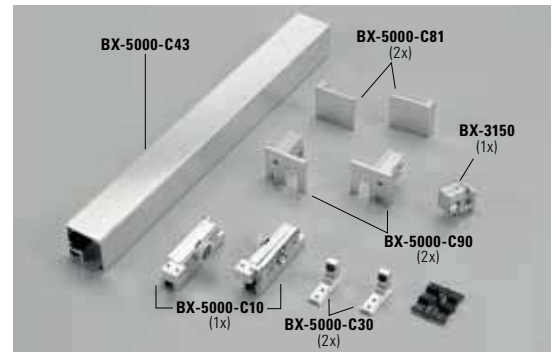
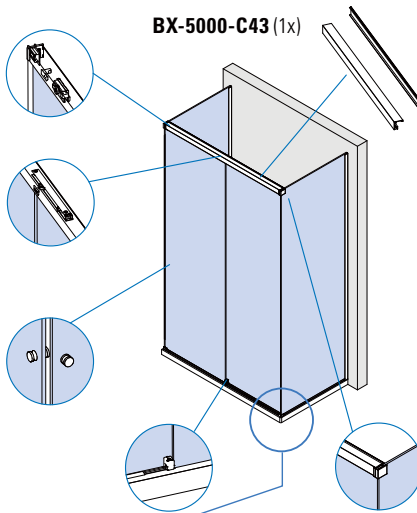

CARATTERISTICHE COMPONENTI /
FEATURES COMPONENTS /
EIGENSCHAFTEN EINZELTEILE ▶ 58

A BX-PT-01 SET 3 L = 1500 / L = 3000 mm

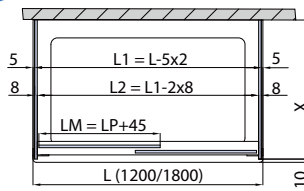
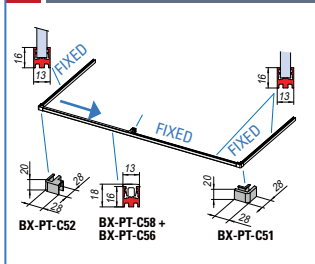

PROFILI A TERRA / FLOOR PROFILES / BODENPROFILE ▶ 106

xme628a

BX-5000 SET 4

L = 1500 mm / L = 3000 mm
DOCCIA CON SPALLA IN VETRO / CORNER SHOWER WITH 2 FIXED PANEL
ECKDUSCHE MIT 2 FESTSTEHENDEN GLASTAFELN

€> BX.31 €KIT > BX.25

MY METALGLAS

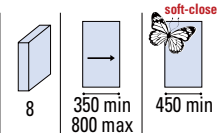

FINITURE
FINISHING - OBERFLÄCHEN:
CR - NO - IXE - BI - OR ▶ 22

COMPONENTI / COMPONENTS / EINZELTEILE

BX-5000-C10 (1x)

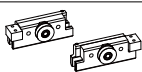

BX-5000-C30 (2x)



BX-5000-C90 SX (1x)



BX-5000-C90 DX (1x)



BX-5000-C81 SX/DX (1x)



BX-3150 (1x)



BX-5006 (1x)



OPTIONAL
SOFT-CLOSE

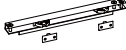

OPTIONAL (1x)

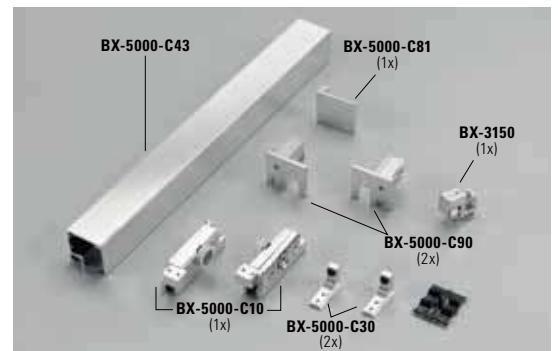
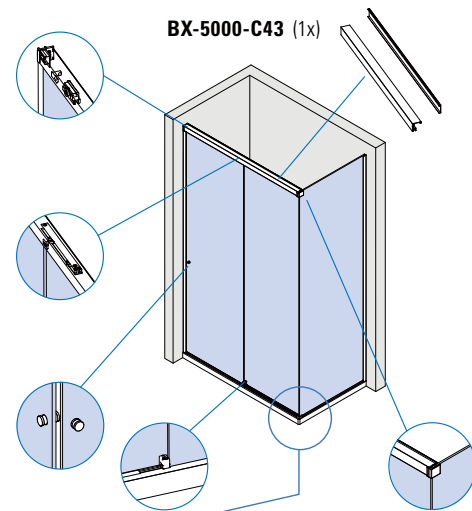

CARATTERISTICHE COMPONENTI /
FEATURES COMPONENTS /
EIGENSCHAFTEN EINZELTEILE ▶ 58

A BX-PT-01 SET 4 L = 1500 / L = 3000 mm

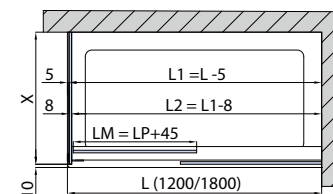
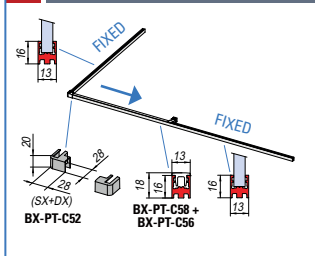

PROFILI A TERRA / FLOOR PROFILES / BODENPROFILE ▶ 106

xme628a

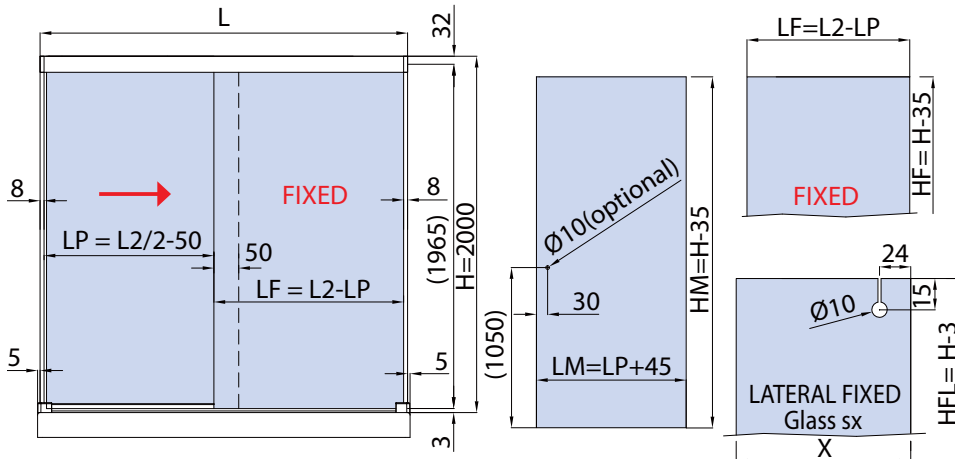
LAVORAZIONE VETRO / GLASS PREPARATION / GLASBEARBEITUNG

CALCOLO VETRO / CALCULATION GLASS / GLASBERECHNUNG

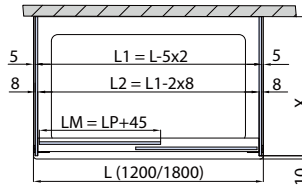
L = PIATTO - SHOWER TRAY - DUSCHTASSE
 L1 = (L) - 5 x 2
 L2 = L1 - 2 x 8
 LP = L2 / 2 - 50
 LM = LP + 45
 LF = (L2 - LP) - * ① / * ② (aria variabile / clearance / Spaltmaß)
 X = CALCOLARE / CALCULATE / BERECHNEN
 HM = H - 35 (1965)

PROFILI A TERRA / FLOOR PROFILES / BODENPROFILE ▶ 106

A BX-PT-01 STANDARD HF = H - 35 = 1965 mm HFL = H - 3

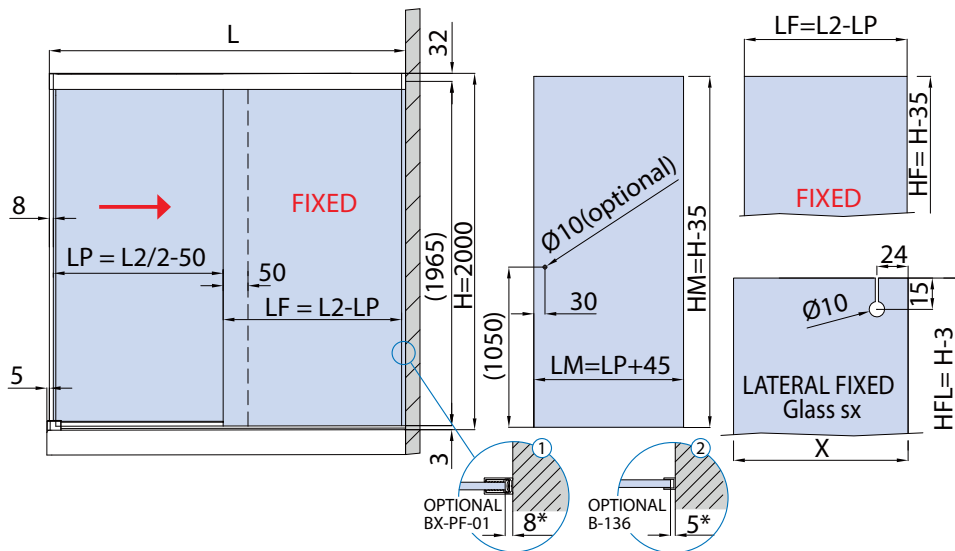
xme628c

CALCOLO VETRO / CALCULATION GLASS / GLASBERECHNUNG

L = PIATTO - SHOWER TRAY - DUSCHTASSE
 L1 = (L) - 5
 L2 = L1 - 8
 LP = L2 / 2 - 50
 LM = LP + 45
 LF = (L2 - LP) - * ① / * ② (aria variabile / clearance / Spaltmaß)
 X = CALCOLARE / CALCULATE / BERECHNEN
 HM = H - 35 (1965)

PROFILI A TERRA / FLOOR PROFILES / BODENPROFILE ▶ 106

A BX-PT-01 STANDARD HF = H - 35 = 1965 mm HFL = H - 3

xme628c

SET 3 / SET 4

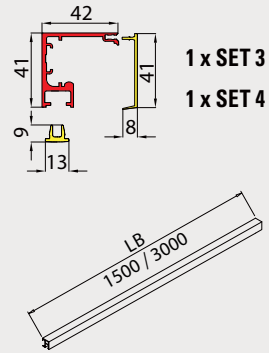
 DA TAGLIARE / ADJUST THE LENGTH /
 BELIEBIG KÜRZBAR ✂

 1 x SET 3
 1 x SET 4

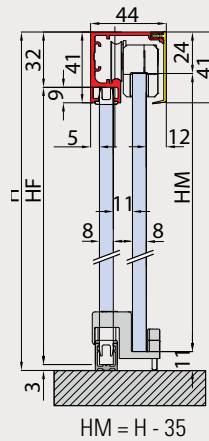
- Regolazione ruota ± 2,5 mm.
- Adjustment ± 2,5 mm.
- Verstellung ± 2,5 mm.

 HF = H - 35
 solo per / only for / nur für
A BX-PT-01
OPTIONAL

L	LP	LM	LF	HM	HF	H	HFL
Piatto Shower tray Duschtaße	Passaggio luce Clear opening width Lichte Durchgangsbreite	Larghezza vetro mobile Sliding glass width Schiebefügel Breite	Larghezza vetro fisso Side fixed glass width Seitenteil Breite	Altezza vetro mobile Sliding glass height Schiebefügel Höhe	Altezza vetro fisso Side fixed glass height Seitenteil Höhe	Altezza doccia Shower height Duschkabine Höhe	Altezza vetro fisso laterale Side fixed glass height Seitenteil (seitlich) Höhe

BX-5000 SET 5

L = 3000 mm

DOCCIA A U / U SHOWER / U DUSCHE

MY METALGLAS

€>BX.32

€KIT>BX.26

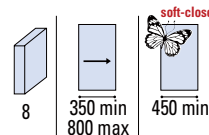

FINITURE
FINISHING - OBERFLÄCHEN:
CR - NO - IXE - BI - OR ▶ 22

COMPONENTI / COMPONENTS / EINZELTEILE

BX-5000-C10 (1x)



BX-5000-C30 (2x)



BX-5000-C90 SX (1x)

BX-5000-C90 DX (1x)



BX-3150 (1x)



BX-5006 (1x)
OPTIONAL
SOFT-CLOSE



OPTIONAL (1x)

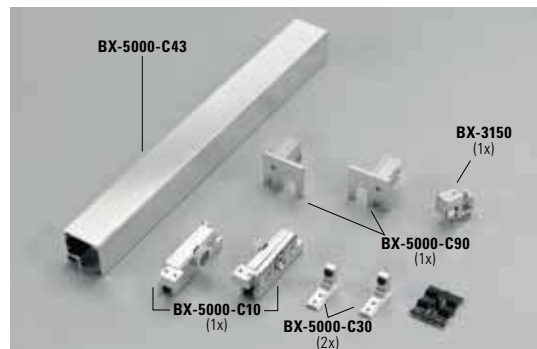
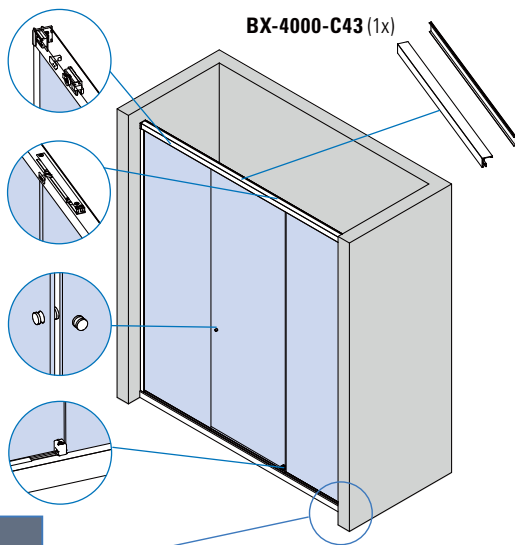

CARATTERISTICHE COMPONENTI /
FEATURES COMPONENTS /
EIGENSCHAFTEN EINZELTEILE ▶ 58

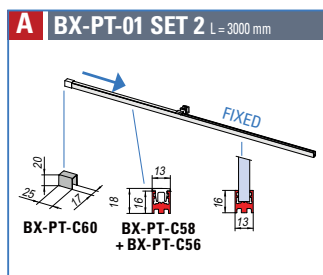

PROFILI A TERRA / FLOOR PROFILES / BODENPROFILE ▶ 106

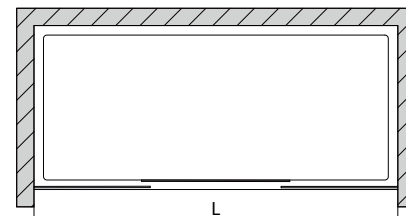

xme628e

BX-5000 SET 6

L = 3000 mm

DOCCIA CON SPALLA IN VETRO / CORNER SHOWER WITH 2 FIXED PANEL
ECKDUSCHE MIT 2 FESTSTEHENDEN GLASTAFELN

€>BX.33 €KIT>BX.27

MY METALGLAS

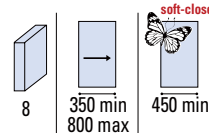

FINITURE
FINISHING - OBERFLÄCHEN:
CR - NO - IXE - BI - OR ▶ 22

COMPONENTI / COMPONENTS / EINZELTEILE

BX-5000-C10
(2x)

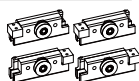

BX-5000-C30 (4x)



BX-5000-C90 SX (1x)

BX-5000-C90 DX (1x)



BX-3150 (2x)



BX-5006 (2x)
OPTIONAL
SOFT-CLOSE



OPTIONAL (2x)

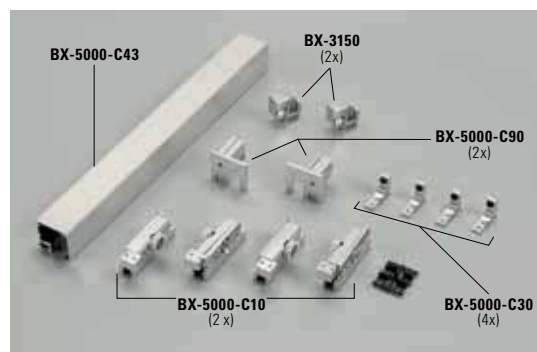
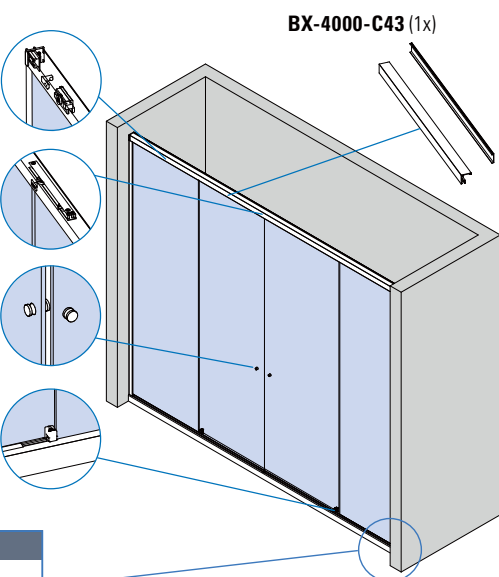

CARATTERISTICHE COMPONENTI /
FEATURES COMPONENTS /
EIGENSCHAFTEN EINZELTEILE ▶ 58

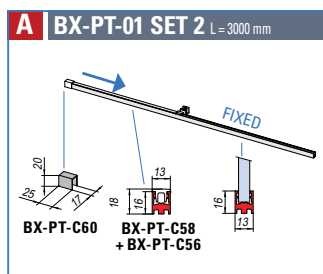

PROFILI A TERRA / FLOOR PROFILES / BODENPROFILE ▶ 106

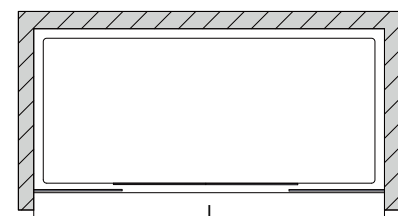

xme628f

SCORREVOLI

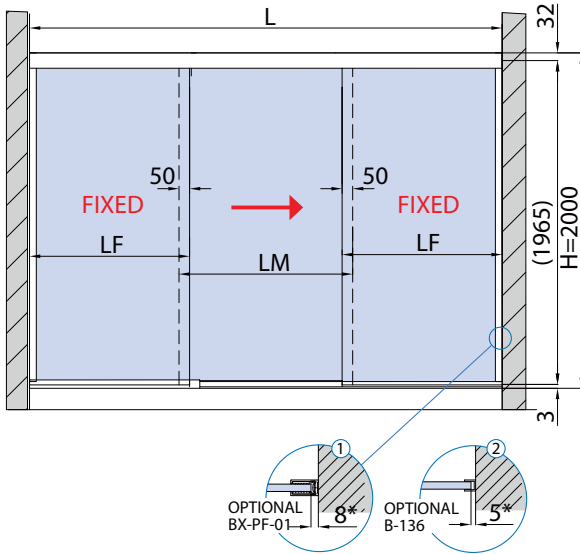
LAVORAZIONE VETRO / GLASS PREPARATION / GLASBEARBEITUNG

CALCOLO VETRO / CALCULATION GLASS / GLASBERECHNUNG

L = PIATTO - SHOWER TRAY - DUSCHTASSE
 $LM = LF = (L + 100) / 3$
 $LF = LF - * (1) / * (2)$
 (aria variabile / clearance / Spaltmaß)
 $HM = H - 35 = 1965 \text{ mm}$

PROFILI A TERRA / FLOOR PROFILES / BODENPROFILE ▶ 106

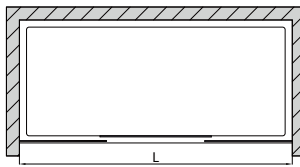
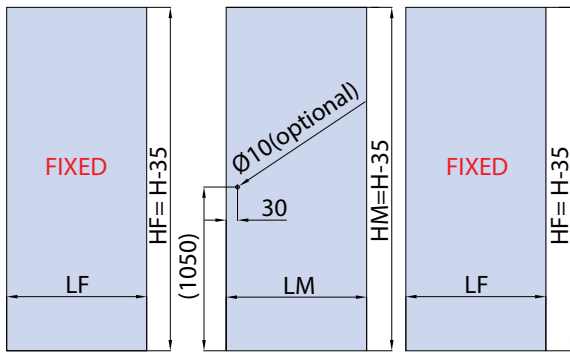
▲ BX-PT-C58
 STANDARD $HF = H - 35 = 1965 \text{ mm}$

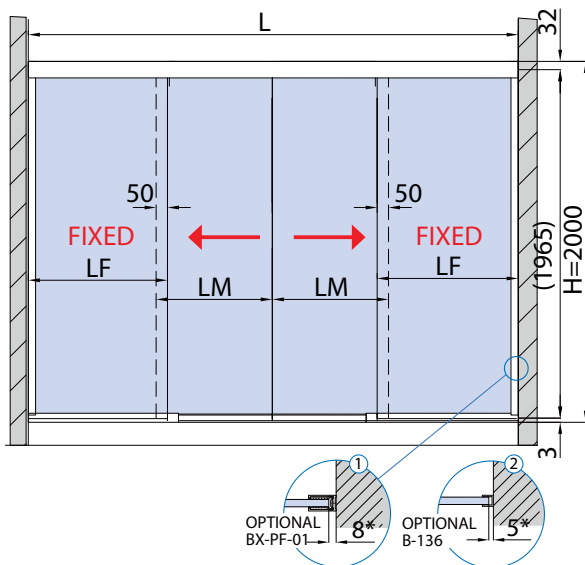

xme628e

CALCOLO VETRO / CALCULATION GLASS / GLASBERECHNUNG

L = PIATTO - SHOWER TRAY - DUSCHTASSE
 $LM = LF = (L + 100) / 4$
 $LF = LF - * (1) / * (2)$
 (aria variabile / clearance / Spaltmaß)
 $HM = H - 35 = 1965 \text{ mm}$

PROFILI A TERRA / FLOOR PROFILES / BODENPROFILE ▶ 106

▲ BX-PT-C58
 STANDARD $HF = H - 35 = 1965 \text{ mm}$

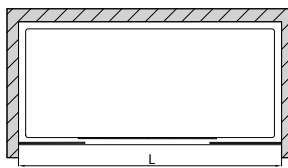
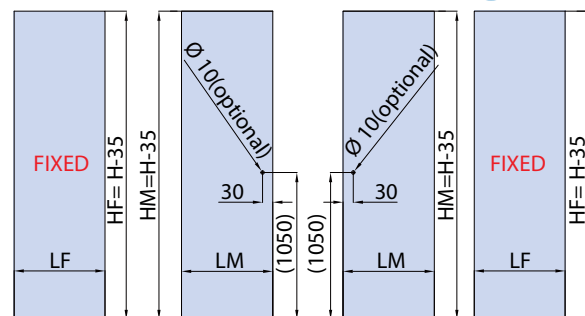

xme628f

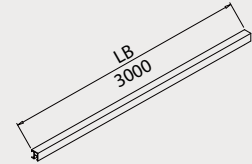
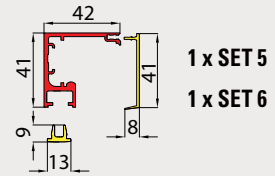
SET 5 / SET 6
DA TAGLIARE / ADJUST THE LENGTH / BELIEBIG KÜRZBAR ✂

- Regolazione ruota ± 2,5 mm.
- Adjustment ± 2,5 mm.
- Verstellung ± 2,5 mm.

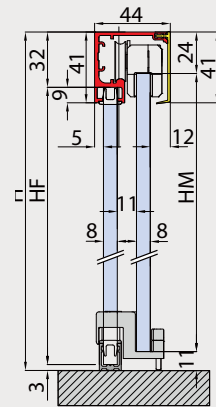
 $HM = H - 35$

$HF = H - 35$
 solo per / only for / nur für
▲ BX-PT-01

OPTIONAL

L	LP	LM	LF	HM	HF	H	HFL
Piatto	Passaggio luce	Larghezza vetro mobile	Larghezza vetro fisso	Altezza vetro mobile	Altezza vetro fisso	Altezza doccia	Altezza vetro fisso laterale
Shower tray	Clear opening width	Sliding glass width	Side fixed glass width	Sliding glass height	Side fixed glass height	Shower height	Side fixed glass height
Duschtasse	Lichte Durchgangsbreite	Schiebeflügel Breite	Seitenteil Breite	Schiebeflügel Höhe	Seitenteil Höhe	Duschkabine Höhe	Seitenteil (seitlich) Höhe

BX-5000

COMPONENTI / COMPONENTS / EINZELTEILE

SCORREVOLI



BX-5000-C40/C43

- Binario con veletta, profilo di chiusura per sede vetro fisso BX-4001 incluso
- Track profile with cover, profile for fixed glass section BX-4001 included
- Laufschiene mit Profilabdeckung, Sichtschutzprofil für Seitenteil Sektor BX-4001 enthalten

CR - NO - IXE - BI - OR

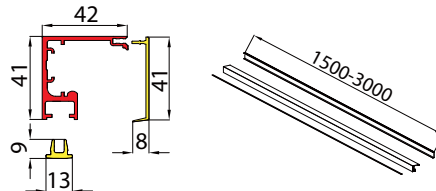

Cod.	Fin. / Fin. / Oberf.
BX-5000-C43-1500 mm	CR / NO / IXE / BI / OR
BX-5000-C43-3000 mm	CR / NO / IXE / BI / OR
BX-5000-C40-1000 x 1000 mm (2 pcs)	CR / NO / IXE / BI / OR

€ BX.35

xme628d



BX-5000-C10

- Set composto da 2 carrelli (1 pc DX + 1 pc SX)
- Set consisting of 2 roller carriers (1 pc right + 1 pc left)
- Set bestehend aus 2 Klemm-Laufwagen (1 Stk Rechts + 1 Stk Links)

CR - NO

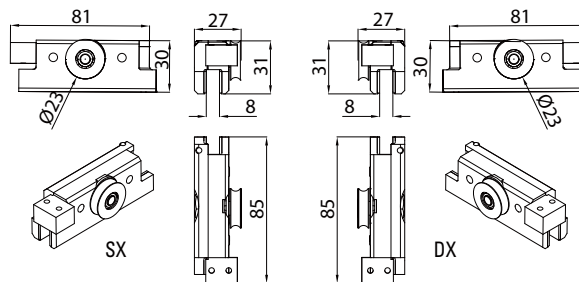

€ BX.36

xme628d



BX-5000-C30

- Stopper

CR - NO

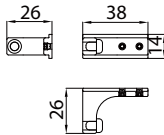

xme628d



BX-5000-C20

- Connettore ad angolo per binario per set 1
- Corner connector for track profile set 1
- Winkelverbinder Laufschiene set 1

CR - NO - NS - BI - OR

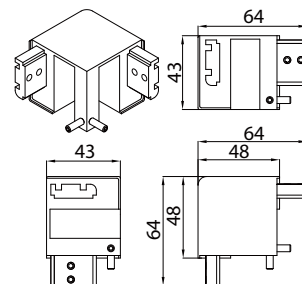

xme628d



BX-5000-C90 DX

- Attacco a parete destro per binario
- Right wall connector for track profile
- Wandhalter rechts für Laufschiene

CR - NO - NS - BI - OR

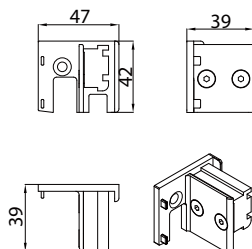

xme628d



BX-5000-C90 SX

- Attacco a parete sinistro per binario
- Left wall connector for track profile
- Wandhalter links für Laufschiene

CR - NO - NS - BI - OR

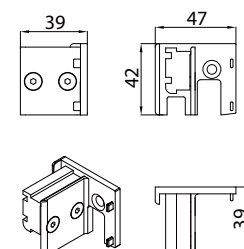

xme628d



BX-5000-C81 DX €►BX.40

- Piastrina destra attacco a vetro per BX-5000-C90
- Right plate glass connector for BX-5000-C90
- Platte Glashalter rechts für BX-5000-C90

CR - NO - NS - BI - OR

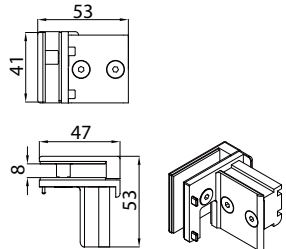

xme628d



BX-5000-C81 SX €►BX.41

- Piastrina sinistra attacco a vetro per BX-5000-C90
- Left plate glass connector for BX-5000-C90
- Platte Glashalter links für BX-5000-C90

CR - NO - NS - BI - OR

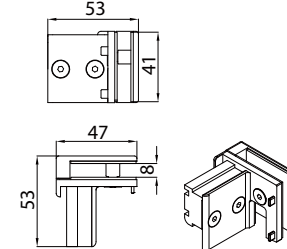

xme628d



BX-3150 €►BX.43

- Guida vetro scorrevole BX-3150 per applicazione con profilo a terra BX-PT-C58 sistema di sgancio della porta per facilitare la pulizia.
- Floor guide sliding panel BX-3150 for installation with floor profile BX-PT-C58 with quick release door function for easy cleaning.
- Schiebetür Bodenführung BX-3150 für Montage mit Bodenprofil BX-PT-C58 mit auslosbarem System um das Reinigen zu erleichtern.

CR - NO - NS - BI - OR



xme628d

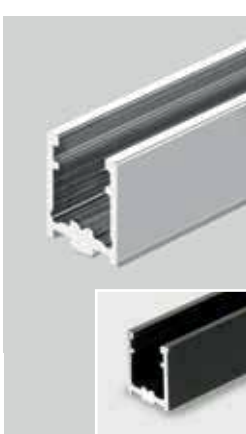

BX PT-C58 €►BX.144

- Profilo per fissaggio a terra o laterale
- Profile for floor and side installation
- Profil Boden Wand-Montage

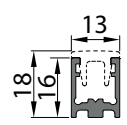

Cod.	Fin./Fin./Fin.
BX-PT-C58-1500 mm	CR - NO - IXE - BI - OR
BX-PT-C58-3000 mm	CR - NO - IXE - BI - OR

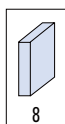

8



BX PT-C56 €►BX.145

- Coperchio per profilo a terra per tratto entrata doccia
- Cover profile for floor profile, shower entry.
- Profilabdeckung Bodenprofil Duscheinstieg

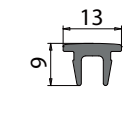

Cod.	Fin./Fin./Fin.
BX-PT-C56-1500 mm	CR - NO - IXE - BI - OR
BX-PT-C56-3000 mm	CR - NO - IXE - BI - OR

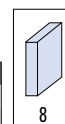

8

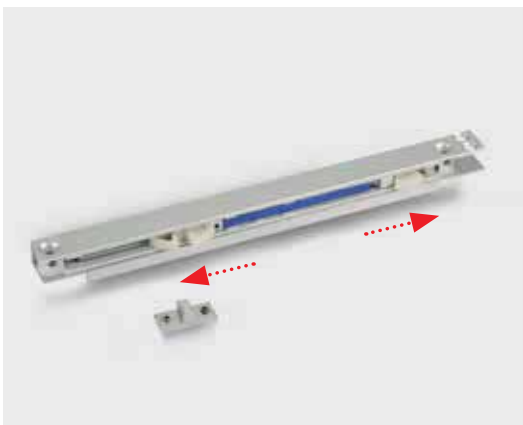

BX-5006 Optional SOFT-CLOSE €►BX.44

- Soft-close in apertura e chiusura
- Double acting Soft-close
- Soft-close doppelt Winkende

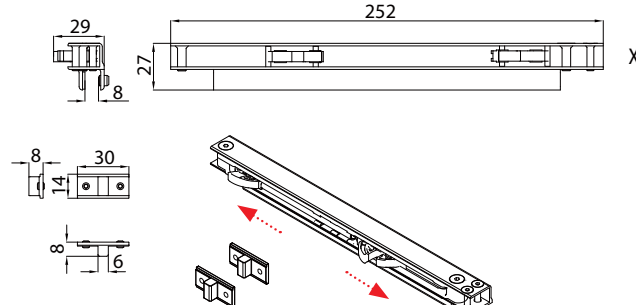

xme628d



SCORREVOLI

LINEA BX-4000

IL BOX DOCCIA MINIMAL E SEMPLICE DA MONTARE

BX-4000 LINEA è il sistema scorrevole per box doccia disponibile nelle versioni ad angolo, lineare e a nicchia. Eleganza e perfezione estetica e funzionale caratterizzano uno tra i brevetti di maggior successo dell'azienda Metalglas.

DESIGN E INNOVAZIONE SENZA PRECEDENTI.

MINIMAL AND EASY TO ASSEMBLE

A sliding system for shower enclosure, available for corner, niche or U-shower installations. Elegance, functionality and essentiality for an exclusive patented concept.

UNIQUE DESIGN AND INNOVATION

EINFACH UND LEICHT ZU MONTIEREN

Schiebetürsysteme für Duschkabine, lieferbar für Eck- Nische- und U-Dusche. Funktionalität und minimale Eleganz für ein exklusives und patentiertes Konzept.

EINZIGARTIGES DESIGN UND INNOVATION.



PLUS

- CONCEPT E BREVETTO ESCLUSIVO
- BINARIO ALTO SOLO 26 MM
- ELEGANTE FUNZIONALE ESSENZIALE
- FACILE DA MONTARE
- POSSIBILITÀ DI SGANCIARE LA GUIDA INFERIORE PER UNA PERFETTA PULIZIA
- PINZE REGOLABILI IN ALTEZZA +/- 2,5MM

- Exclusive patented concept
- Rail only 26 mm high
- Elegant, functional, essential
- Easy to assemble
- Quick release door function for easy cleaning
- +/- 2,5 mm clamps adjustment

- Exclusives und patentiertes Konzept
- Schienenhöhe nur 26 mm
- Qualität, Optik, Funktionalität
- Einfache Montage
- Die auslösbare Bodenführung erleichtert das Reinigen
- Höhenverstellbare Laufwagen +/- 2,5 mm

BX-4000 LINEA 30

- Sistema scorrevole per box doccia, altezza binario solo 26 mm, disponibile per versioni in angolo, lineare e in nicchia. Materiale: alluminio. Finitura: cromo lucido, nero opaco e oro opaco.
- Sliding system for shower box, track profile's height only 26 mm, available for corners, single doors or for niche installations. Material: aluminium. Finish: polished chrome, matt black and matt gold.
- Schiebetüresystem für Duschkabine, Laufschiene Höhe nur 26 mm, lieferbar für Eck-, Linear und Nischenduschen. Material: Aluminium. Oberfläche: chrom poliert, matt schwarz and matt gold.



SCORREVOLI

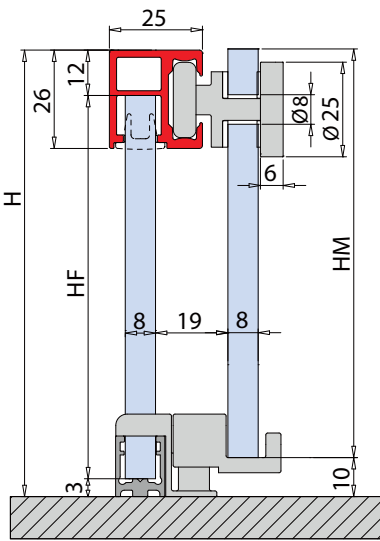

SET 1 € ▶ BX.52
€ KIT ▶ BX.46

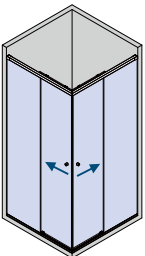

SET 2 € ▶ BX.53
€ KIT ▶ BX.47

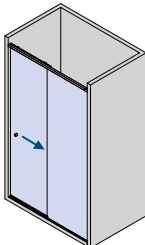

SET 3 € ▶ BX.54
€ KIT ▶ BX.48

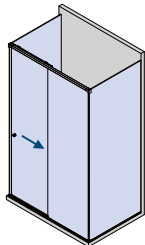

SET 4 € ▶ BX.55
€ KIT ▶ BX.49

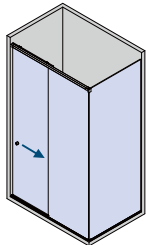

SET 5 € ▶ BX.56
€ KIT ▶ BX.50

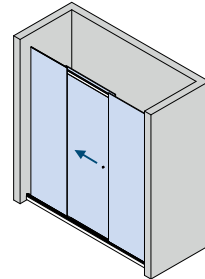

SET 6 € ▶ BX.57
€ KIT ▶ BX.51

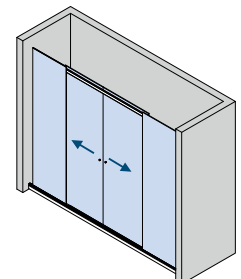

BX-4000 LINEA 30 SET 1

L = 1000 x 1000 mm

DOCCIA IN ANGOLO / CORNER SHOWER / ECKDUSCHE

MY METALGLAS

€>BX.52

€KIT>BX.46



350 min
390 max

Fin. / Fin. / Oberf.

CR	NO
Cromo lucido	Nero opaco
Polished chrome	Matt black
Chrom glänzend	Matt schwarz

COMPONENTI / COMPONENTS / EINZELTEILE

BX-4000-C30 (2x)

BX-4000-C10 (4x)

BX-4000-C90 (2x)

BX-4000-C20 (1x)

OPTIONAL

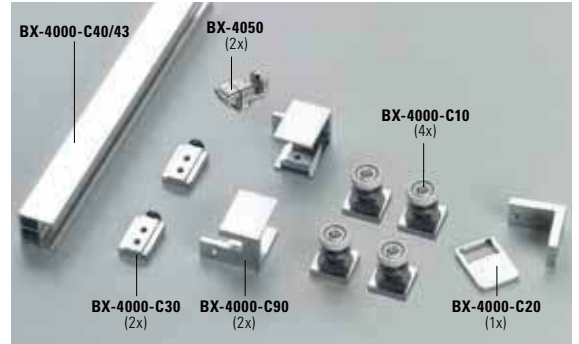
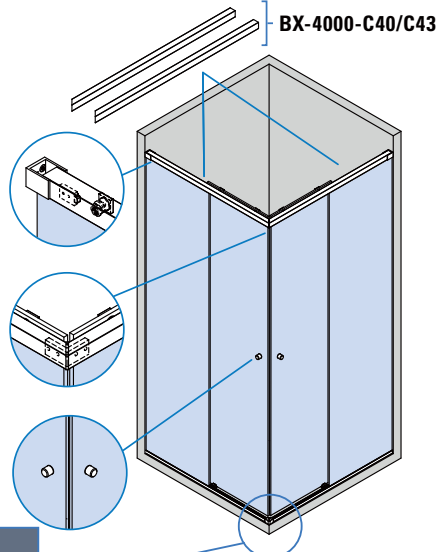

CARATTERISTICHE COMPONENTI /
FEATURES COMPONENTS /
EIGENSCHAFTEN EINZELTEILE ▶ 70

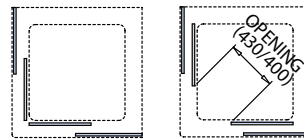
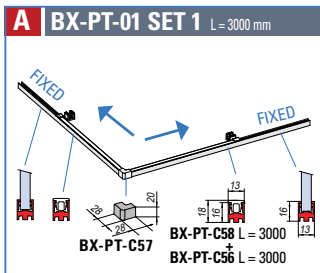

PROFILI A TERRA / FLOOR PROFILES / BODENPROFILE ▶ 106

xme512a

BX-4000 LINEA 30 SET 2

L = 1500 mm / L = 3000 mm

DOCCIA IN NICCHIA / NICHE SHOWER / NISCHENDUSCHE

MY METALGLAS

€>BX.53

€KIT>BX.47



550 min
750 max

Fin. / Fin. / Oberf.

CR	NO
Cromo lucido	Nero opaco
Polished chrome	Matt black
Chrom glänzend	Matt schwarz

COMPONENTI / COMPONENTS / EINZELTEILE

BX-4000-C30 (1x)

BX-4000-C10 (2x)

BX-4000-C90 (2x)

OPTIONAL

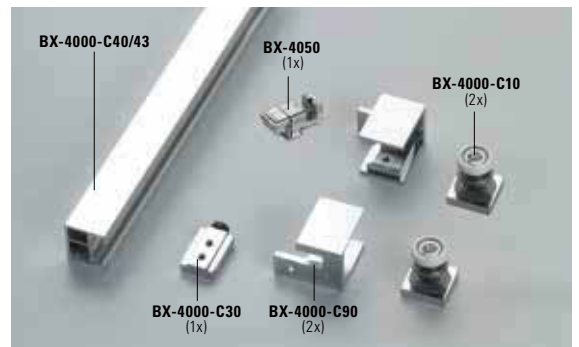
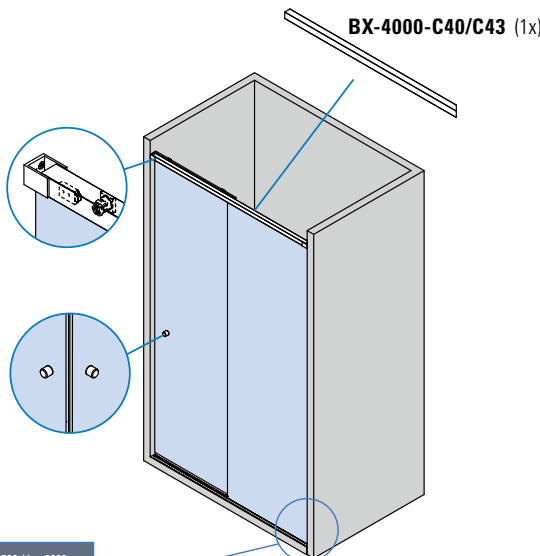

CARATTERISTICHE COMPONENTI /
FEATURES COMPONENTS /
EIGENSCHAFTEN EINZELTEILE ▶ 70

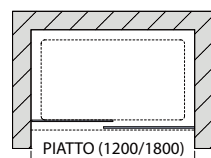
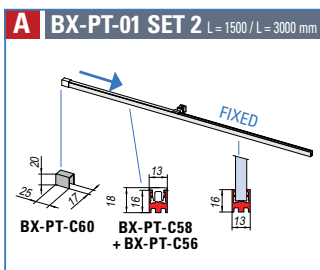

PROFILI A TERRA / FLOOR PROFILES / BODENPROFILE ▶ 106

xme512a

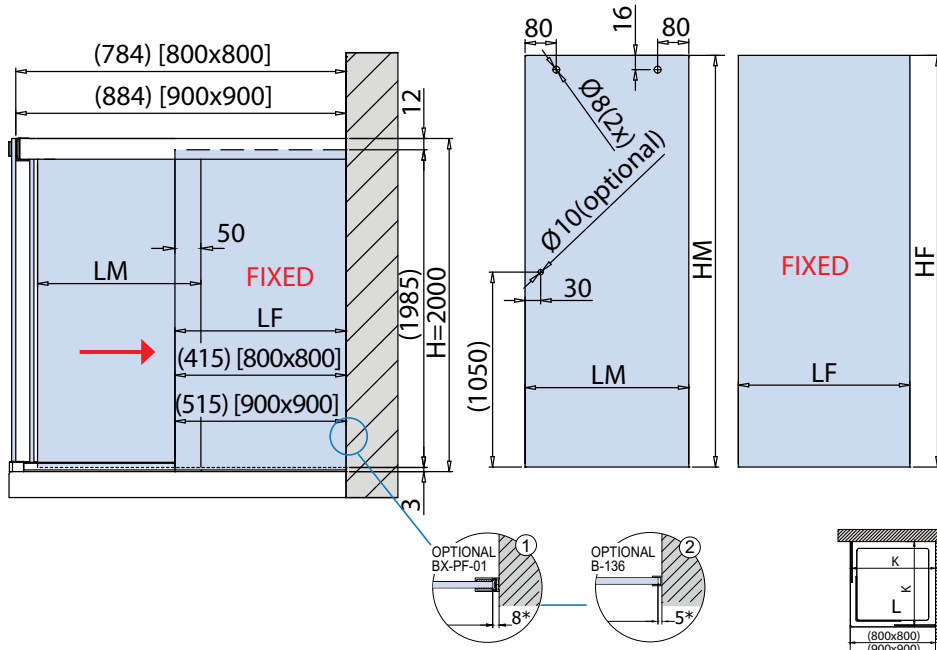
LAVORAZIONE VETRO / GLASS PREPARATION / GLASBEARBEITUNG

CALCOLO VETRO / CALCULATION GLASS / GLASBERECHNUNG

L = 800 x 800 mm (900 x 900) mm

LM = L / 2

LF = [(L / 2)] - (aria variabile / clearance / Spaltmaß)

HM = H - 10 = 1990 mm

PROFILI A TERRA / FLOOR PROFILES / BODENPROFILE ▶ 106

A BX-PT-01 STANDARD HF = H - 15 = 1985 mm

xme512b

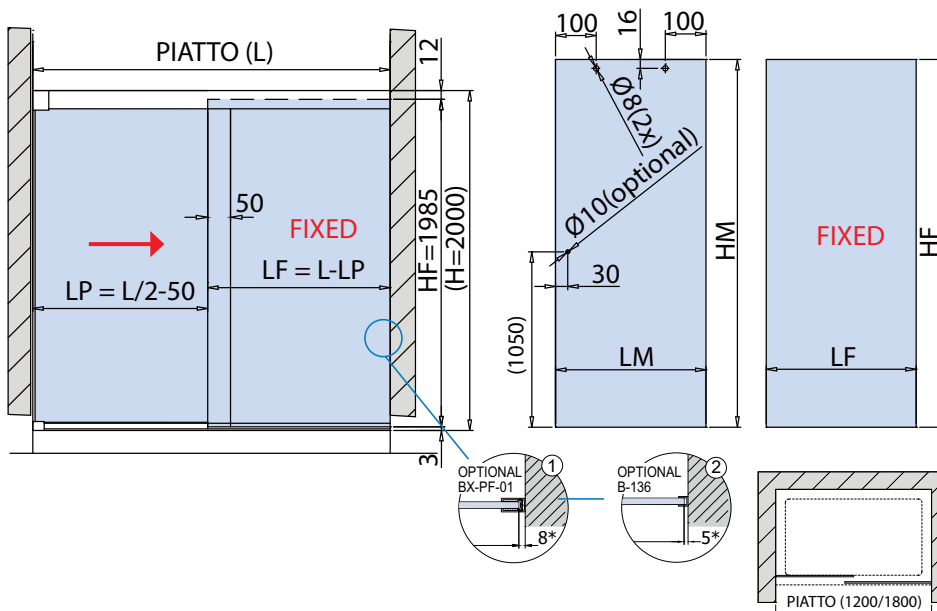
CALCOLO VETRO / CALCULATION GLASS / GLASBERECHNUNG

L = PIATTO DOCCIA - SHOWER TRAY - DUSCHTASSE

LP = L / 2 - 50

LM = LP + 45

LF = L - LP - (aria variabile / clearance / Spaltmaß)

HM = H - 10 = 1990 mm

PROFILI A TERRA / FLOOR PROFILES / BODENPROFILE ▶ 106

A BX-PT-01 STANDARD HF = H - 15 = 1985 mm

xme512b

SET 1 / SET 2

DA TAGLIARE / ADJUST THE LENGTH / BELIEBIG KÜRZBAR ✂

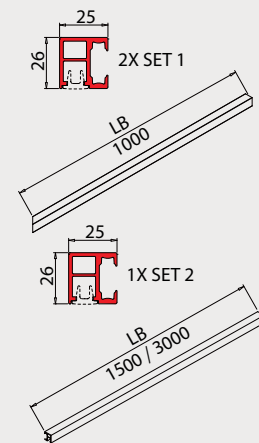

- Regolazione ruota ± 2,5 mm.
- Adjustment ± 2,5 mm.
- Verstellung ± 2,5 mm.

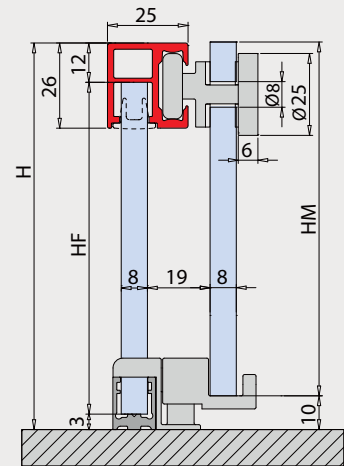

HM = H - 10
HF = H - 15
solo per / only for / nur für **A BX-PT-01**

OPTIONAL

L	LP	LM	LF	HM	HF	H
Piatto Shower tray Duschtasse	Passaggio luce Clear opening width Lichte Durchgangsbreite	Larghezza vetro mobile Sliding glass width Schiebeflügel Breite	Larghezza vetro fisso Side fixed glass width Seitenteil Breite	Altezza vetro mobile Sliding glass height Schiebeflügel Höhe	Altezza vetro fisso Side fixed glass height Seitenteil Höhe	Altezza doccia Shower height Duschkabine Höhe

SCORREVOLI

BX-4000 LINEA 30 SET 3

L = 1500 mm / L = 3000 mm
DOCCIA A U / U SHOWER / U DUSCHE

MY METALGLAS

€ BX.54
€ KIT BX.48

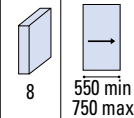

Fin. / Fin. / Oberf.

CR	NO
Cromo lucido	Nero opaco
Polished chrome	Matt black
Chrom glänzend	Matt schwarz

COMPONENTI / COMPONENTS / EINZELTEILE

- BX-4000-C30 (1x)
- BX-4000-C10 (2x)
- BX-4000-C90 (2x)
- BX-4000-C81 (2x)
- OPTIONAL

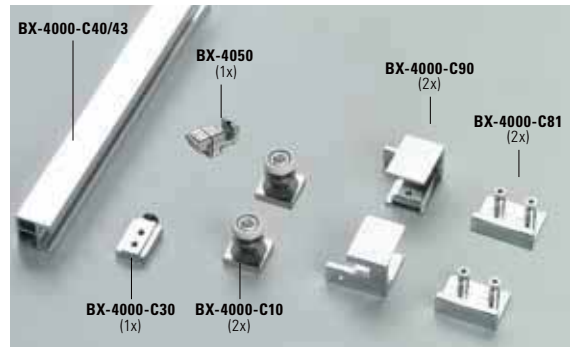
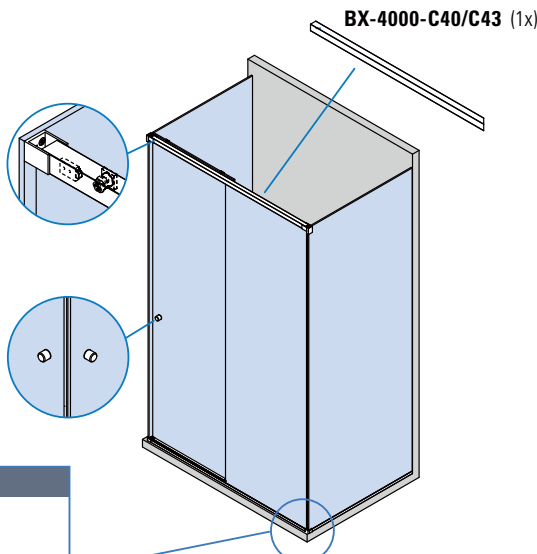

CARATTERISTICHE COMPONENTI /
FEATURES COMPONENTS /
EIGENSCHAFTEN EINZELTEILE ▶ 70

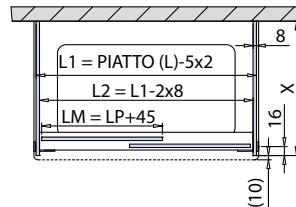
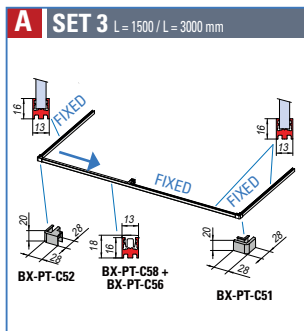

PROFILI A TERRA / FLOOR PROFILES / BODENPROFILE ▶ 106

xme512a

BX-4000 LINEA 30 SET 4

L = 1500 mm / L = 3000 mm
DOCCIA CON SPALLA IN VETRO / CORNER SHOWER WITH 2 FIXED PANEL
ECKDUSCHE MIT 2 FESTSTEHENDEN GLASTAFELN

€ BX.55 MY METALGLAS
€ KIT BX.49

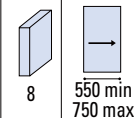

Fin. / Fin. / Oberf.

CR	NO
Cromo lucido	Nero opaco
Polished chrome	Matt black
Chrom glänzend	Matt schwarz

COMPONENTI / COMPONENTS / EINZELTEILE

- BX-4000-C30 (1x)
- BX-4000-C10 (1x)
- BX-4000-C90 SX (1x)
- BX-4000-C90 DX (1x)
- BX-4000-C81 (1x)
- OPTIONAL

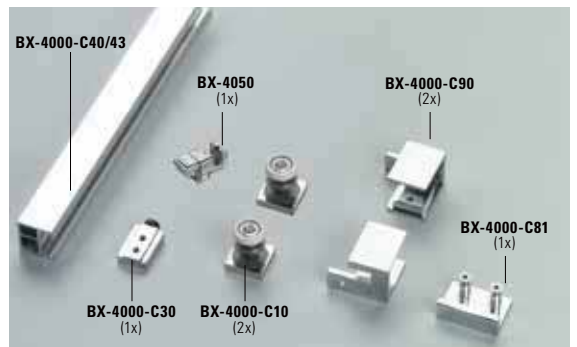
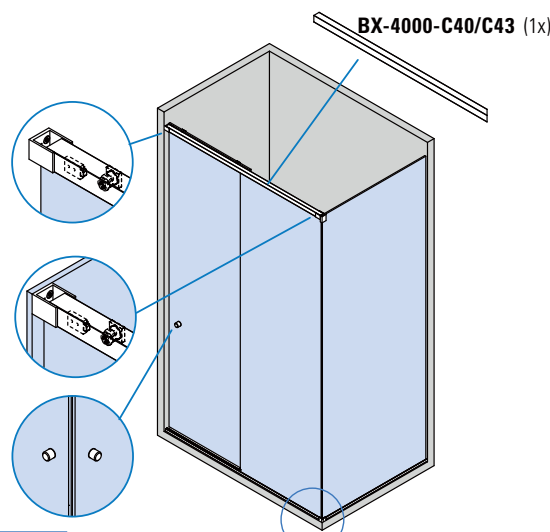

CARATTERISTICHE COMPONENTI /
FEATURES COMPONENTS /
EIGENSCHAFTEN EINZELTEILE ▶ 70

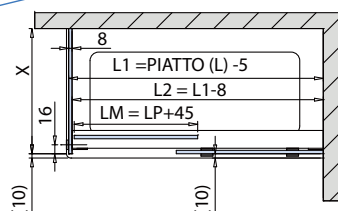
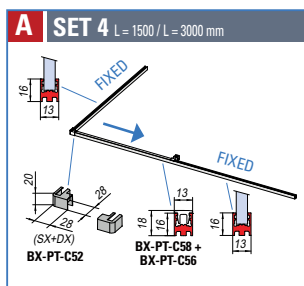

PROFILI A TERRA / FLOOR PROFILES / BODENPROFILE ▶ 106

xme512a

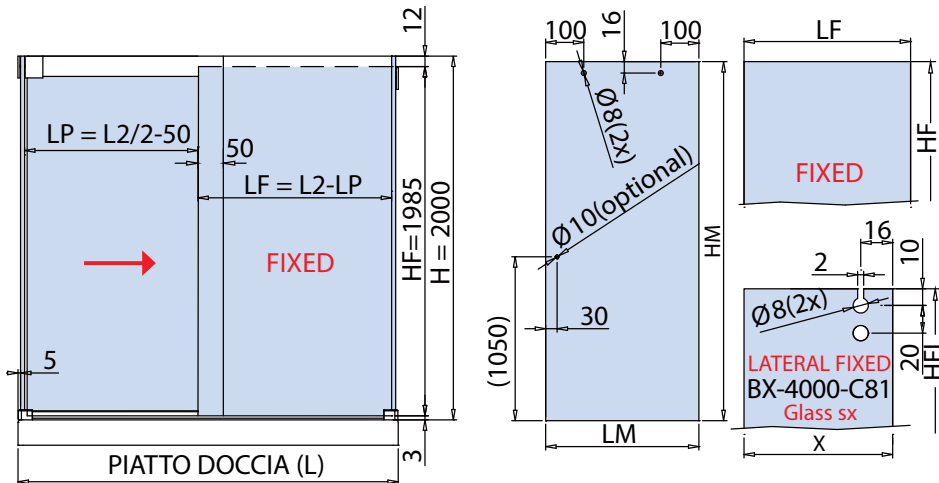
LAVORAZIONE VETRO / GLASS PREPARATION / GLASBEARBEITUNG

CALCOLO VETRO / CALCULATION GLASS / GLASBERECHNUNG

L = 1200 - 1800 mm
 L1 = L - 5 x 2
 L2 = L1 - 2 x 8
 LP = L2 / 2 - 50
 LM = LP + 45
 LF = L2 - LP
 X = calcolare / calculate / berechnen
 HM = H - 10 = 1990 mm

PROFILI A TERRA / FLOOR PROFILES / BODENPROFILE ▶ 106

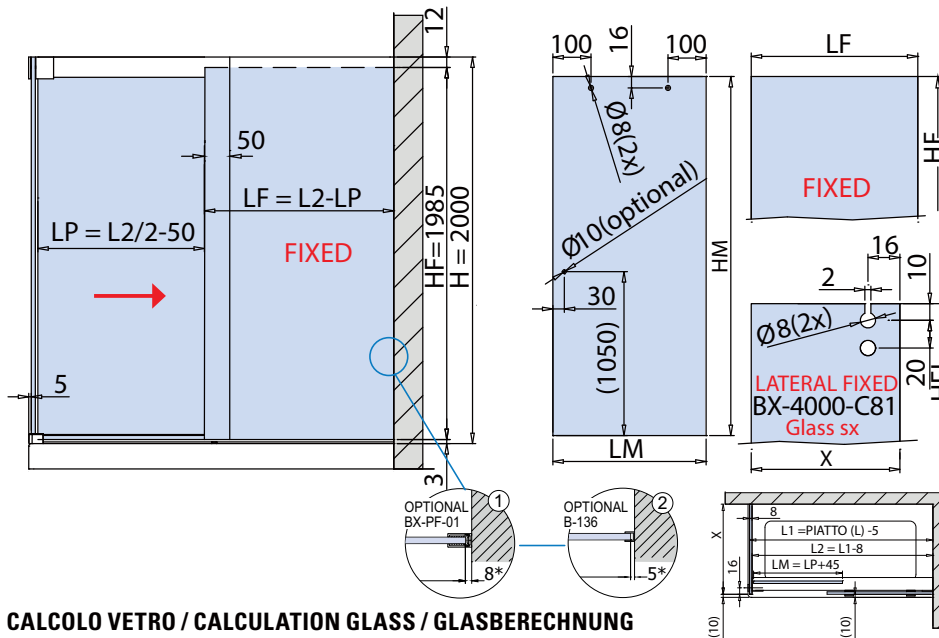
A BX-PT-01 STANDARD HF = H - 15 = 1985 mm HFL = H - 3 xme512b



CALCOLO VETRO / CALCULATION GLASS / GLASBERECHNUNG

L = PIATTO DOCCIA - SHOWER TRAY - DUSCHTASSE
 L1 = L - 5
 L2 = L1 - 8
 LP = L2 / 2 - 50
 LM = LP + 45
 LF = L2 - LP - *① / *② (aria variabile / clearance / Spaltmaß)
 X = calcolare / calculate / berechnen
 HM = H - 10 = 1990 mm

PROFILI A TERRA / FLOOR PROFILES / BODENPROFILE ▶ 106

A BX-PT-01 STANDARD HF = H - 15 = 1985 mm HFL = H - 3 xme512b

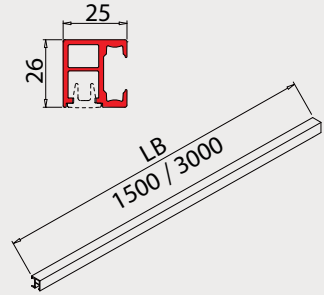
L	LP	LM	LF	HM	HF	H	HFL
Piatto Shower tray Duschtaße	Passaggio luce Clear opening width Lichte Durchgangsbreite	Larghezza vetro mobile Sliding glass width Schiebefügel Breite	Larghezza vetro fisso Side fixed glass width Seitenteil Breite	Altezza vetro mobile Sliding glass height Schiebefügel Höhe	Altezza vetro fisso Side fixed glass height Seitenteil Höhe	Altezza doccia Shower height Duschkabine Höhe	Altezza vetro fisso laterale Side fixed glass height Seitenteil (seitlich) Höhe

SET 3 / SET 4
DA TAGLIARE / ADJUST THE LENGTH / BELIEBIG KÜRZBAR ✂

- Regolazione ruota ± 2,5 mm.
- Adjustment ± 2,5 mm.
- Verstellung ± 2,5 mm.

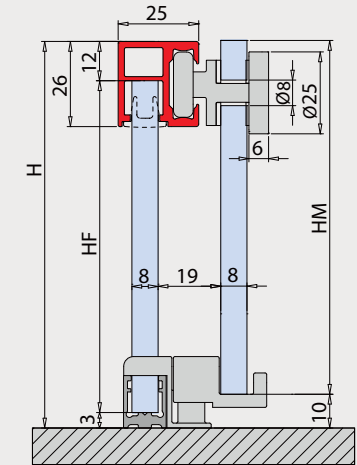

HM = H - 10
 HF = H - 15
 solo per / only for / nur für
A BX-PT-01

OPTIONAL

SCORREVOLI

BX-4000 LINEA 30 SET 5

L = 3000 mm

DOCCIA A U / U SHOWER / U DUSCHE

MY METALGLAS

€>BX.56

€KIT>BX.50



Fin. / Fin. / Oberf.

CR	NO
Cromo lucido	Nero opaco
Polished chrome	Matt black
Chrom glänzend	Matt schwarz

COMPONENTI / COMPONENTS / EINZELTEILE

BX-4000-C30 (2x)

BX-4000-C10 (2x)

BX-4000-C90 (2x)

OPTIONAL

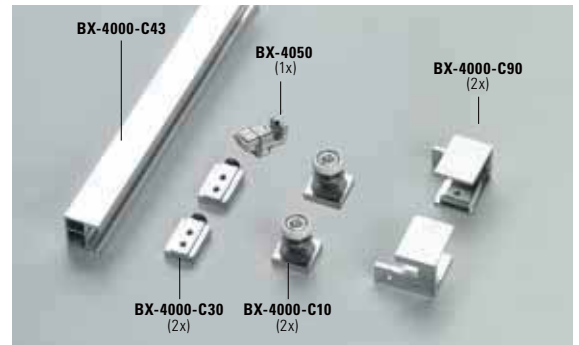
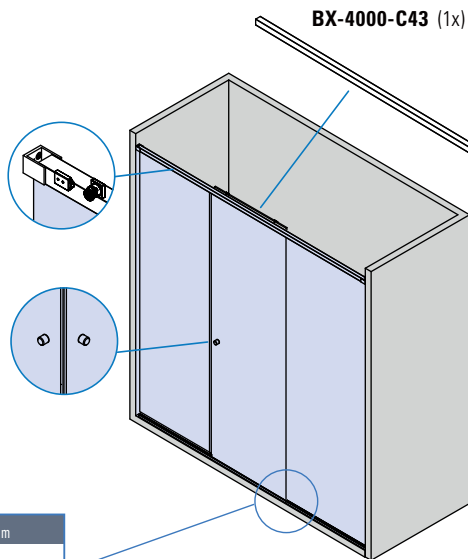

CARATTERISTICHE COMPONENTI /
FEATURES COMPONENTS /
EIGENSCHAFTEN EINZELTEILE ▶ 70

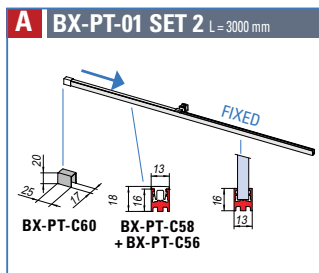

PROFILI A TERRA INCLUSI / FLOOR PROFILES INCLUDED / BODENPROFILE INKL. ▶ 106

xme512d

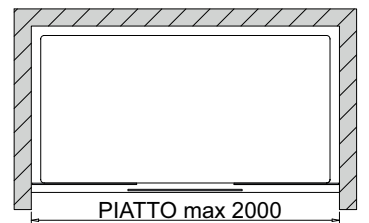

BX-4000 LINEA 30 SET 6

L = 3000 mm

DOCCIA CON SPALLA IN VETRO / CORNER SHOWER WITH 2 FIXED PANEL
ECKDUSCHE MIT 2 FESTSTEHENDEN GLASTAFELN

€>BX.57
€KIT>BX.51

MY METALGLAS

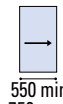

Fin. / Fin. / Oberf.

CR	NO
Cromo lucido	Nero opaco
Polished chrome	Matt black
Chrom glänzend	Matt schwarz

COMPONENTI / COMPONENTS / EINZELTEILE

BX-4000-C30 (4x)

BX-4000-C10 (4x)

BX-4000-C90 (2x)

OPTIONAL

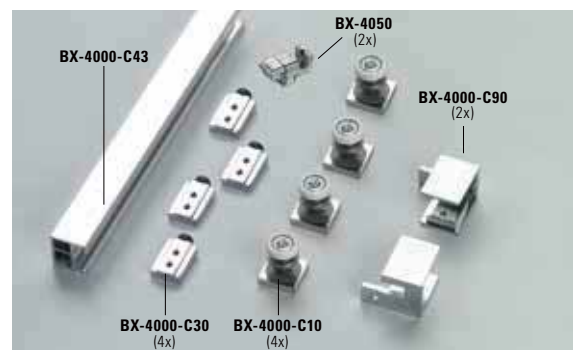
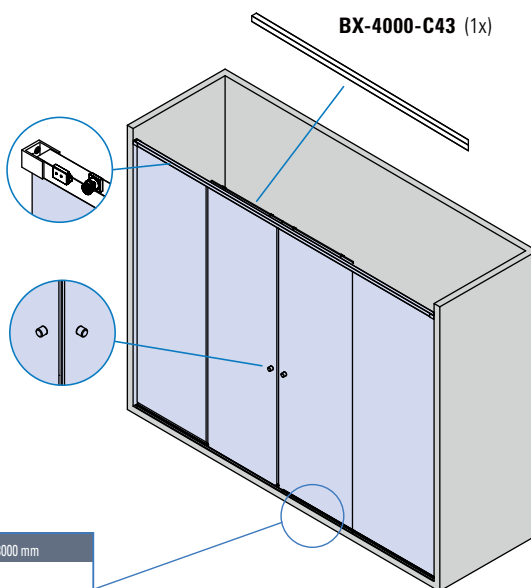

CARATTERISTICHE COMPONENTI /
FEATURES COMPONENTS /
EIGENSCHAFTEN EINZELTEILE ▶ 70

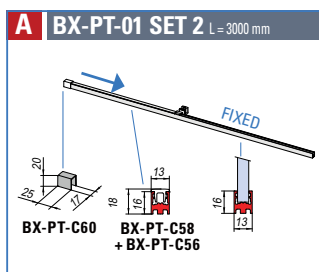

PROFILI A TERRA INCLUSI / FLOOR PROFILES INCLUDED / BODENPROFILE INKL. ▶ 106

xme512e

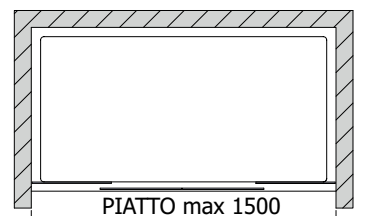

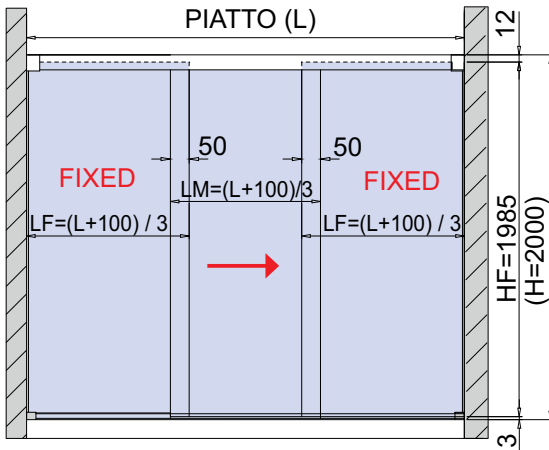
LAVORAZIONE VETRO / GLASS PREPARATION / GLASBEARBEITUNG

CALCOLO VETRO / CALCULATION GLASS / GLASBERECHNUNG

$L = \max 2000 \text{ mm}$
 $LM = (L + 100) / 3$
 $LF = (L + 100) / 3$
 LF = (aria variabile / clearance / Spaltmaß)
 $HM = H - 10 = 1990 \text{ mm}$

PROFILI A TERRA / FLOOR PROFILES / BODENPROFILE ▶ 106

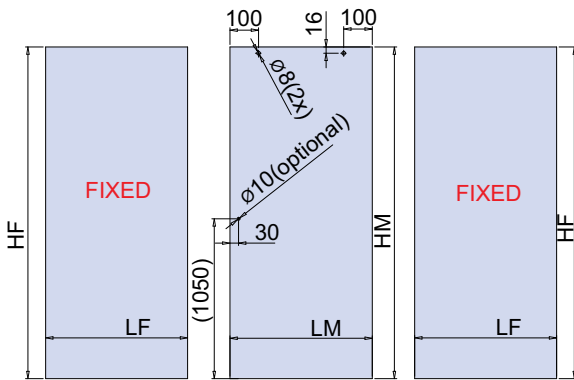
▲ BX-PT-C58
 STANDARD $HF = H - 15 = 1985 \text{ mm}$

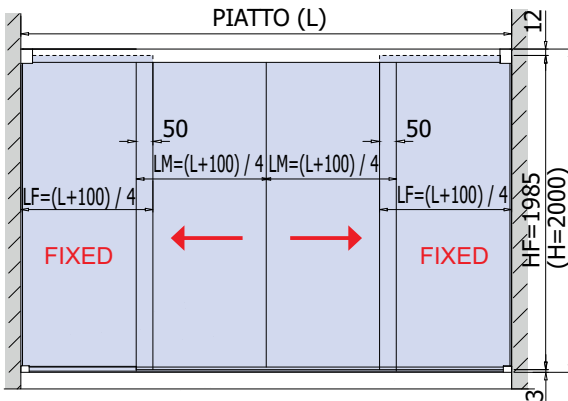

xme512d

CALCOLO VETRO / CALCULATION GLASS / GLASBERECHNUNG

$L = \max 1500 \text{ mm}$
 $LM = (L + 100) / 4$
 $LF = (L + 100) / 4$
 LF = (aria variabile / clearance / Spaltmaß)
 $HM = H - 10 = 1990 \text{ mm}$

PROFILI A TERRA / FLOOR PROFILES / BODENPROFILE ▶ 106

▲ BX-PT-C58
 STANDARD $HF = H - 15 = 1985 \text{ mm}$

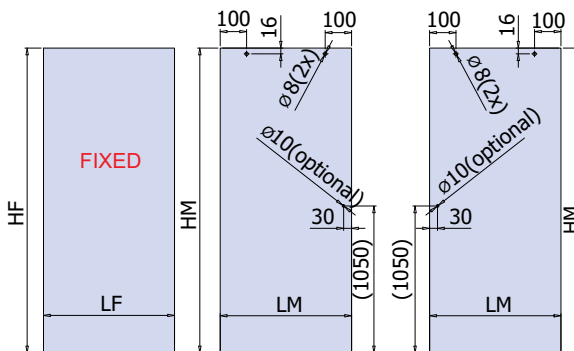

xme512e

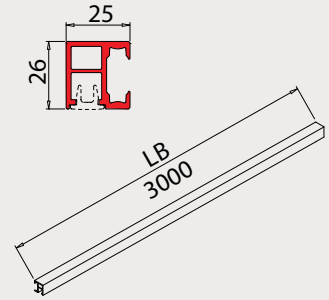
SET 5 / SET 6
DA TAGLIARE / ADJUST THE LENGTH / BELIEBIG KÜRZBAR ✂

SCORREVOLI

- Regolazione ruota ± 2,5 mm.
- Adjustment ± 2,5 mm.
- Verstellung ± 2,5 mm.

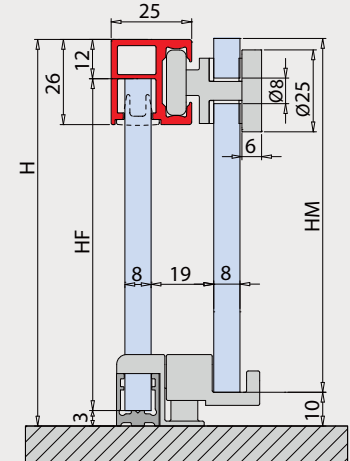

$HM = H - 10$
 $HF = H - 15$
 solo per / only for / nur für
▲ BX-PT-01

OPTIONAL

L	LP	LM	LF	HM	HF	H	HFL
Piatto	Passaggio luce	Larghezza vetro mobile	Larghezza vetro fisso	Altezza vetro mobile	Altezza vetro fisso	Altezza doccia	Altezza vetro fisso laterale
Duschtasse	Lichte Durchgangsbreite	Schiebeflügel Breite	Seitenteil Breite	Schiebeflügel Höhe	Seitenteil Höhe	Duschkabine Höhe	Seitenteil (seitlich) Höhe

BX-4000 LINEA 30

COMPONENTI / COMPONENTS / EINZELTEILE

SCORREVOLI

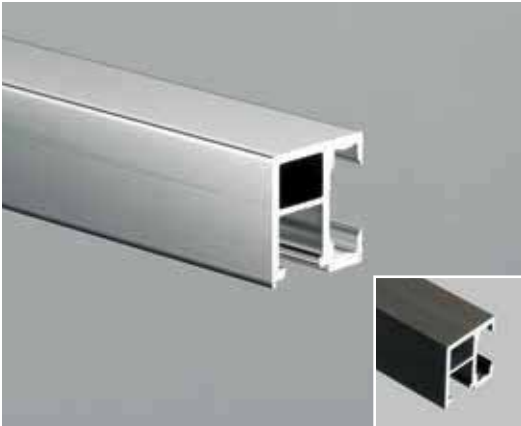

BX-4000-C43/BX-4000-C40

- Binario con veletta BX-4001 inclusa
- Track profile with cover profile BX-4001 included
- Laufschiene mit Sichtschutzprofil BX-4001 enthalten

CR - NO - OR

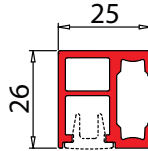

Cod.	Fin. / Fin. / Oberf.
BX-4000-C43-1500 mm	CR / NO / OR
BX-4000-C43-3000 mm	CR / NO / OR
BX-4000-C40-1000 x 1000 mm (2 pcs 45°)	CR / NO / OR

€ ▶ BX.59
€ ▶ BX.60



xme216



BX-4000-C10

- Ruota
- Roller
- Laufrolle

CR - NO - OR

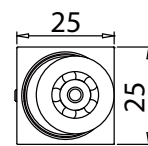
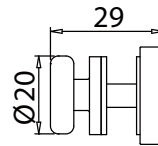
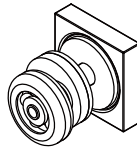

xme512c

€ ▶ BX.61



BX-4000-C90 DX

- Attacco a parete destro per binario
- Right wall connector for track profile
- Wandhalter rechts für Laufschiene

CR - NO - OR

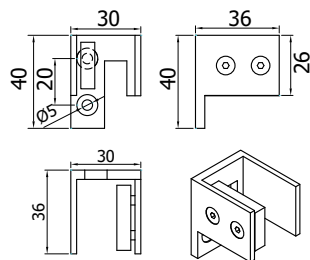

xme512c

€ ▶ BX.62



BX-4000-C90 SX

- Attacco a parete sinistro per binario
- Left wall connector for track profile
- Wandhalter links für Laufschiene

CR - NO - OR

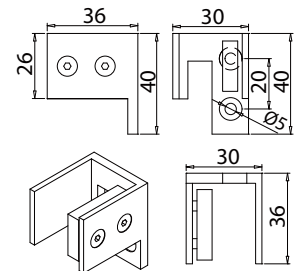

xme512c

€ ▶ BX.63

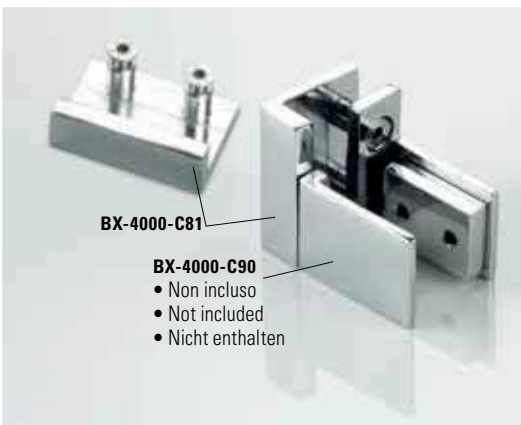

BX-4000-C81

- Piastrina attacco a vetro binario
- Plate glass connector rail
- Platte Glashalter Laufschiene

CR - NO - OR

BX-4000-C81

BX-4000-C90

- Non incluso
- Not included
- Nicht enthalten

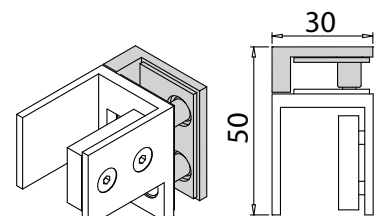
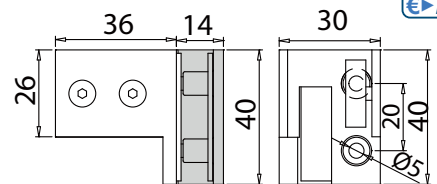

xfb-065

€ ▶ BX.64

BX-4000-C30

- Stopper
- CR - NO - OR

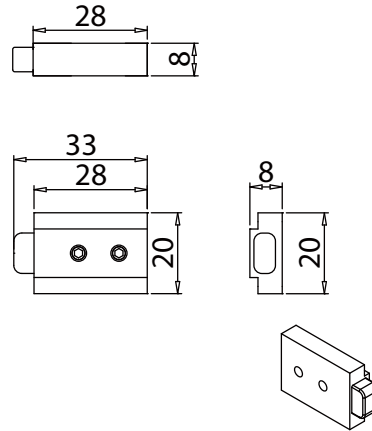

xme512c

BX-4000-C20

- Connettore ad angolo per binario set 1
- Corner connector for track profile set 1
- Winkelverbinder Laufschiene set 1
- CR - NO - OR

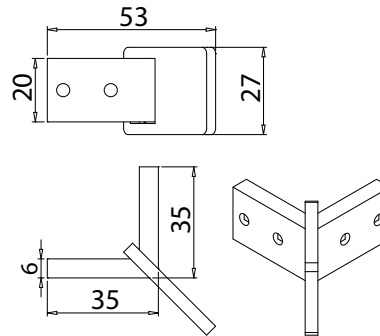

xme512c

BX-4050

- Guida vetro scorrevole BX-4050 per applicazione con profilo a terra BX-PT-C58 con sistema di sgancio della porta per facilitare la pulizia.
- Floor guide sliding panel BX-4050 for installation with floor profile BX-PT-C58 with quick release door function for easy cleaning.
- Schiebetür Bodenführung BX-4050 für Montage mit Bodenprofil BX-PT-C58 mit auslosbarem System um das Reinigen zu erleichtern.

CR - NO - OR

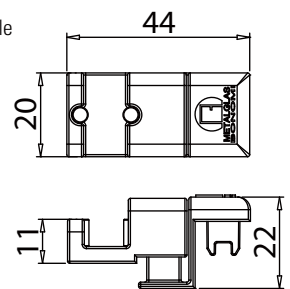

xme512c

BX-PT-C58

- Profilo per fissaggio a terra o laterale
- Profile for floor and side installation
- Profil Boden- Wandmontage

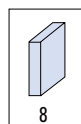
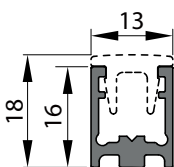

Cod.	Fin. / Fin. / Oberf.
BX-PT-C58-1500 mm	CR / NO / OR
BX-PT-C58-3000 mm	CR / NO / OR

BX-PT-C56

- Coperchio per profilo a terra per tratto entrata doccia
- Cover profile for floor profile, shower entry.
- Profilabdeckung Bodenprofil Duscheinstieg

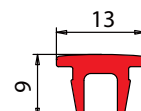

Cod.	Fin. / Fin. / Oberf.
BX-PT-C56-1500 mm	CR / NO / OR
BX-PT-C56-3000 mm	CR / NO / OR



SCORREVOLI



BX-6050 PURA

VEDRAI L'USUALE CON OCCHI DIVERSI

Con Eterea ci siamo accorti che per noi innovare è consuetudine. Volevamo semplificare un prodotto classico per renderlo il più possibile minimale, bello ed accattivante, ed alla fine abbiamo fatto "scompare tutto".

PER IL SUO DESIGN E PER L'INNOVAZIONE CHE LA CONTRADDISTINGUE ETEREA SI CANDIDA AD ESSERE LA MIGLIORE SUL MERCATO.

YOU WILL SEE THE USUAL WITH DIFFERENT EYES

With Eterea we realised that it is customary for us to innovate. We set out to simplify a classic product to make it as minimal, beautiful and as alluring as possible, and ultimately we made "everything disappear". Due to its design and the innovation that distinguishes it, Eterea boasts it is the best on the market.

SIE WERDEN DAS NORMALE MIT ANDEREN AUGEN BETRACHTEN

Mit Eterea haben wir bemerkt, dass Innovation für uns üblich ist. Wir wollten ein klassisches Produkt vereinfachen, um es möglichst minimal zu gestalten, schön und attraktiv, und schließlich haben wir „alles verschwinden lassen“. Aufgrund des herausragenden Designs und der Innovation konkurriert Eterea, um die Beste auf dem Markt zu werden.

BOX DOCCIA MODELLO TRADIZIONALE

TRADITIONAL SHOWER ENCLOSURE MODEL
TRADITIONELLES DUSCHKABINEMODELL

INVISIBILE IN
PURA
BX-6050

INVISIBILE IN PURA BX-6050
UNSICHTBAR PURA BX-6050

SCORREVOLI

NEW

PLUS

- DESIGN "TECNICO" CON RUOTE A VISTA
- NESSUNO STOPPER A VISTA
- SISTEMA ANTISOLLEVAMENTO DI SICUREZZA INVISIBILE

- "Technical" design, visible wheels
- No visible stopper
- Invisible safety anti-lift system

- "Technisches" Design mit sichtbaren Räder
- Kein sichtbarer Stopper
- Unsichtbare Sicherung gegen das Hochschieben

BX-6050 PURA

- Profilo completamente libero e semplificazione della pulizia, quindi eliminazione totale di depositi e residui dovuti al normale utilizzo. Costruita in alluminio è disponibile nelle finiture cromo lucido e effetto inox.
- A completely free profile also means simplification of cleaning, therefore complete elimination of deposits and residues due to normal use. Made of aluminium, it is available in polished chrome and inox effect.
- Ein vollständig freies Profil bedeutet auch vereinfachte Reinigung, daher werden Ablagerungen und Rückstände durch normalen Gebrauch komplett beseitigt. Hergestellt aus Aluminium und ist mit Oberflächen in Chrom glänzend und Edelstahl ähnlich.



SCORREVOLI





SET 1 €►BX.75
€KIT►BX.69

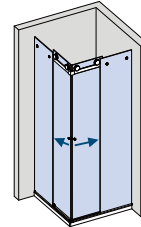

SET 2 €►BX.76
€KIT►BX.70

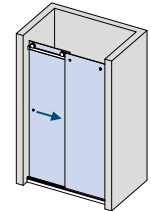

SET 3 €►BX.77
€KIT►BX.71

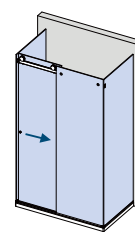

SET 4 €►BX.78
€KIT►BX.72

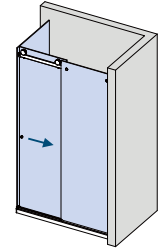

SET 5 €►BX.79
€KIT►BX.73

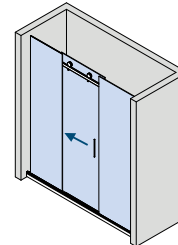

SCORREVOLI

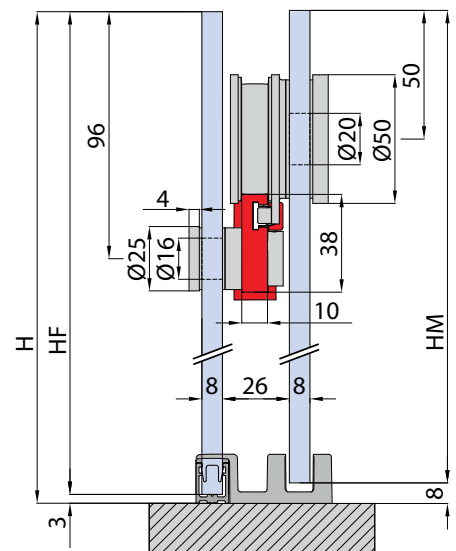

BX-6050 SET 1

L = 1000 x 1000mm

DOCCIA IN ANGOLO / CORNER SHOWER / ECKDUSCHE

MY METALGLAS

€> BX.75

€KIT > BX.69

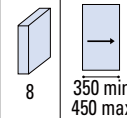

Fin. / Fin. / Oberf.

CR	IXE
Cromo lucido	Effetto inox satinato
Polished chrome	Inox effect
Chrom glänzend	Inox effekt

COMPONENTI / COMPONENTS / EINZELTEILE

- BX-6050-C90 (2x)
- BX-6050-C70 (4x)
- BX-6050-C30 (2x)
- BX-6050-C10 (4x)
- BX-6050-C20 (1x)
- OPTIONAL

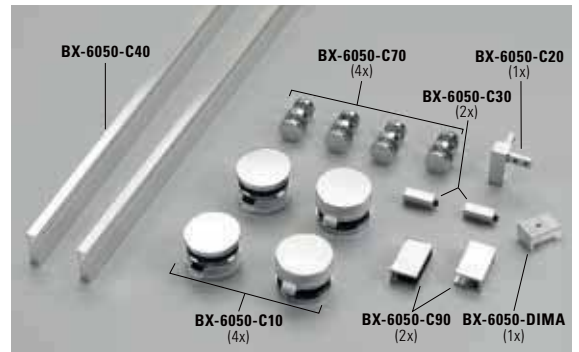
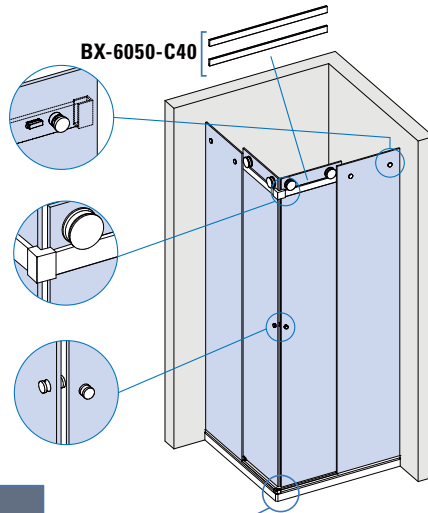

CARATTERISTICHE COMPONENTI /
FEATURES COMPONENTS /
EIGENSCHAFTEN EINZELTEILE ▶ 80

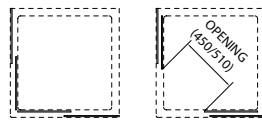
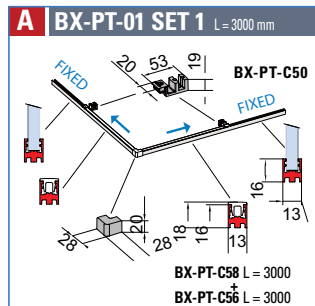

PROFILI A TERRA / FLOOR PROFILES / BODENPROFILE ▶ 106

xme627a

BX-6050 SET 2

L = 1500mm / L = 3000mm

DOCCIA IN NICCHIA / NICHE SHOWER / NISCHENDUSCHE

MY METALGLAS

€> BX.76

€KIT > BX.70

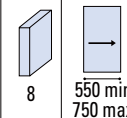

Fin. / Fin. / Oberf.

CR	IXE
Cromo lucido	Effetto inox satinato
Polished chrome	Inox effect
Chrom glänzend	Inox effekt

COMPONENTI / COMPONENTS / EINZELTEILE

- BX-6050-C10 (2x)
- BX-6050-C90 (2x)
- BX-6050-C70 (2x)
- BX-6050-C30 (1x)
- OPTIONAL

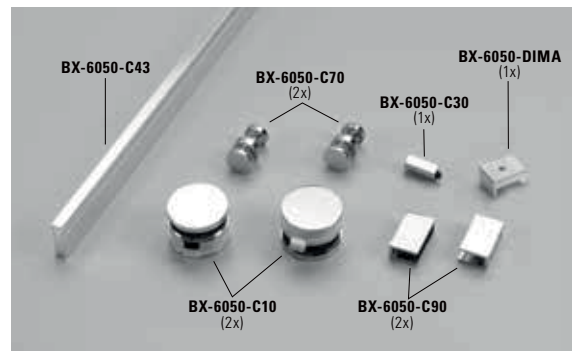
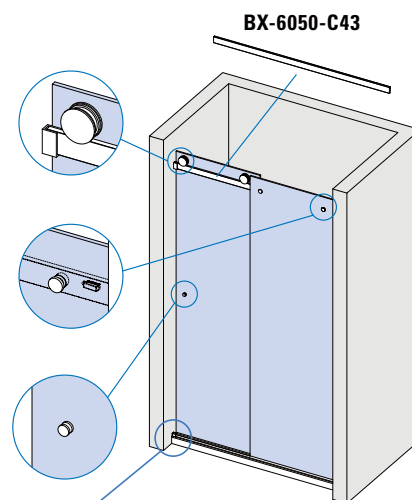

CARATTERISTICHE COMPONENTI /
FEATURES COMPONENTS /
EIGENSCHAFTEN EINZELTEILE ▶ 80

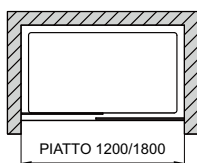
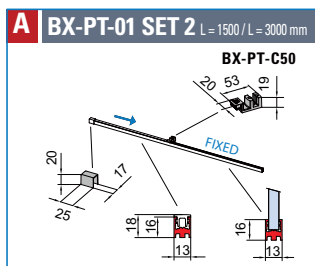

PROFILI A TERRA / FLOOR PROFILES / BODENPROFILE ▶ 106

xme627a

LAVORAZIONE VETRO / GLASS PREPARATION / GLASBEARBEITUNG

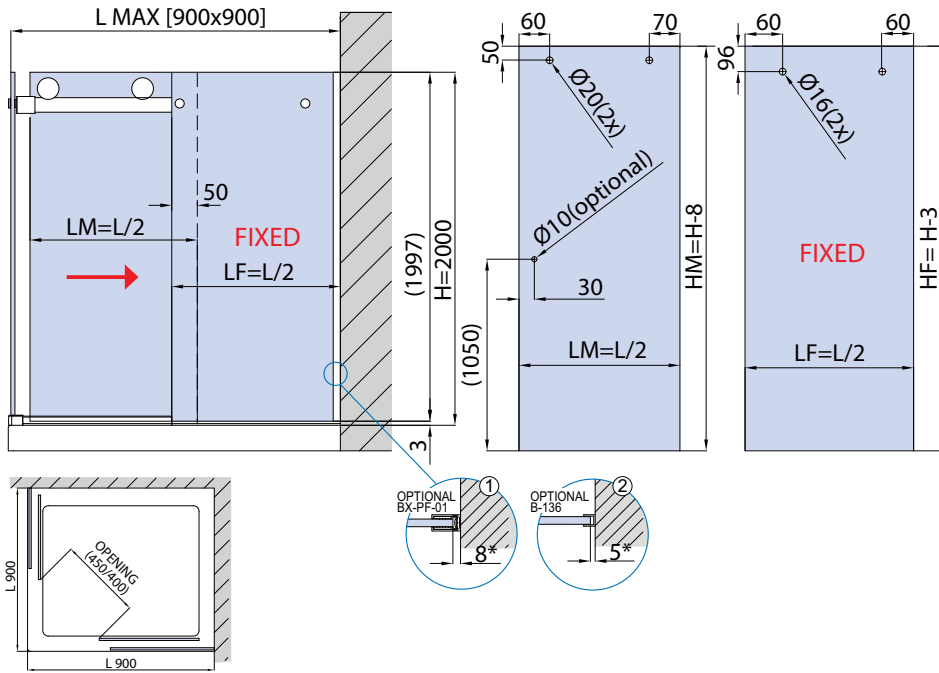

CALCOLO VETRO / CALCULATION GLASS / GLASBERECHNUNG

PIATTO - SHOWER TRAY - DUSCHTASSE (L) = (900x900) mm

Vetro Mobile Larghezza (LM) = L / 2

Vetro Fisso Larghezza (LF) = [(L / 2)] - * ① / * ② (aria variabile / clearance / Spaltmaß)

Vetro Mobile Altezza (HM) = H - 8 = 1992 mm

PROFILI A TERRA / FLOOR PROFILES / BODENPROFILE ▶ 106

BX-PT-01 STANDARD HF = H - 3 = 1997 mm

xme627b

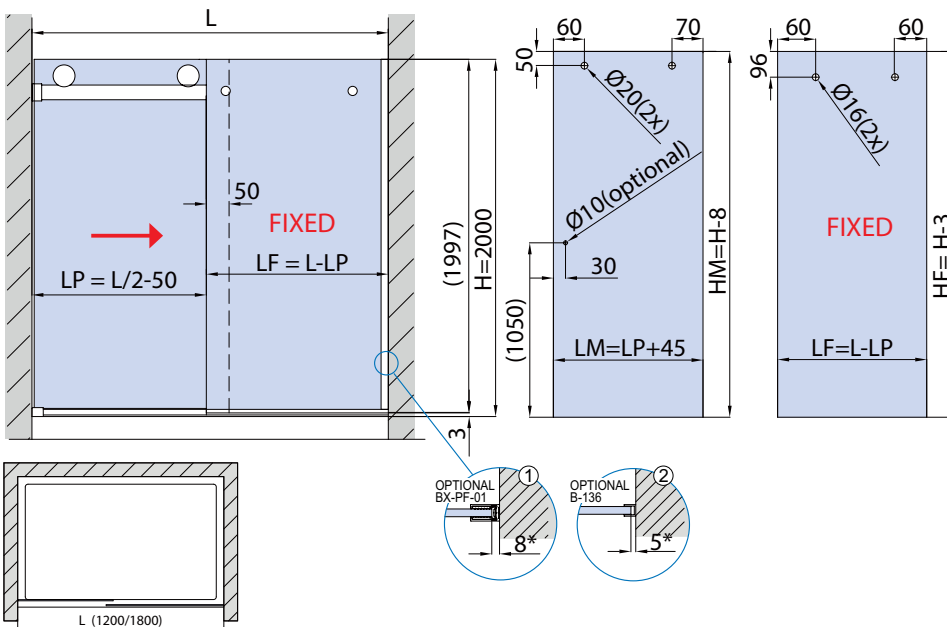

CALCOLO VETRO / CALCULATION GLASS / GLASBERECHNUNG

L = PIATTO - SHOWER TRAY - DUSCHTASSE

Passaggio (LP) = L / 2 - 50

Vetro Mobile Larghezza (LM) = LP + 45

Vetro Fisso Larghezza (LF) = L - LP - * ① / * ② (aria variabile / clearance / Spaltmaß)

Vetro Mobile Altezza (HM) = H - 8 = 1992 mm

PROFILI A TERRA / FLOOR PROFILES / BODENPROFILE ▶ 106

BX-PT-01 STANDARD HF = H - 3 = 1997 mm

xme627b

SET 1 / SET 2

DA TAGLIARE / ADJUST THE LENGTH / BELIEBIG KÜRZBAR ✂

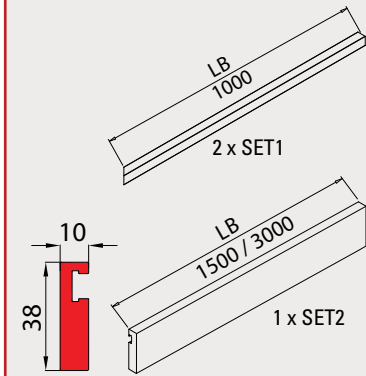

- Regolazione ± 3 mm.
- Adjustment ± 3 mm.
- Verstellung ± 3 mm.

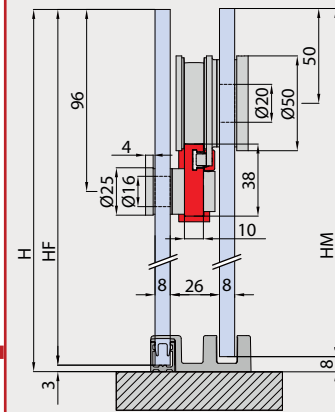

HM = H - 8
HF = H - 3
solo per / only for / nur für
BX-PT-01

OPTIONAL



L	LP	LM	LF	HM	HF	H
Piatto Shower tray Duschtasse	Passaggio luce Clear opening width Lichte Durchgangsbreite	Larghezza vetro mobile Sliding glass width Schiebeflügel Breite	Larghezza vetro fisso Side fixed glass width Seitenteil Breite	Altezza vetro mobile Sliding glass height Schiebeflügel Höhe	Altezza vetro fisso Side fixed glass height Seitenteil Höhe	Altezza doccia Shower height Duschkabine Höhe

BX-6050 SET 3

L = 1500mm / L = 3000mm

DOCCIA A U / U SHOWER / U DUSCHE

MY METALGLAS

€>BX.77

€KIT>BX.71

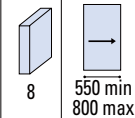

Fin. / Fin. / Oberf.

CR	IXE
Cromo lucido	Effetto inox satinato
Polished chrome	Inox effect
Chrom glänzend	Inox effekt

COMPONENTI / COMPONENTS / EINZELTEILE

BX-6050-C10 (2x)



BX-6050-C90(2x)
BX-6050-C81 (2x)



BX-6050-C70 (2x)



BX-6050-C30 (1x)



OPTIONAL

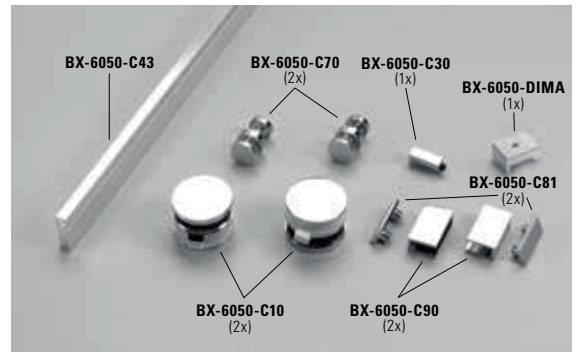
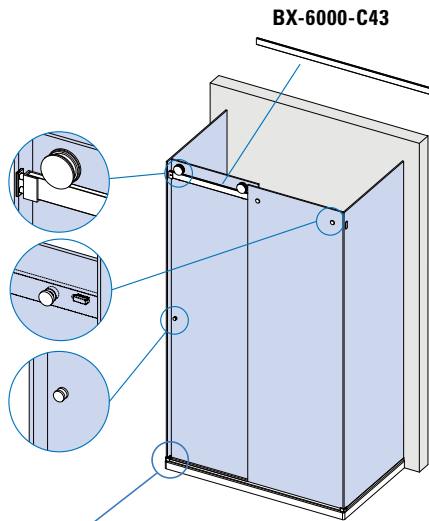

CARATTERISTICHE COMPONENTI /
FEATURES COMPONENTS /
EIGENSCHAFTEN EINZELTEILE ▶ 80

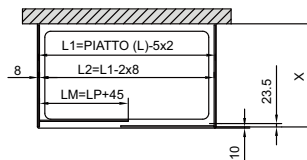
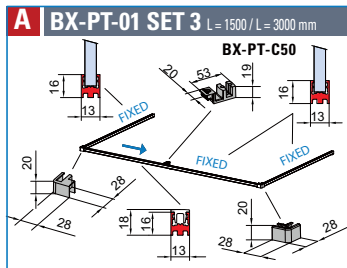

PROFILI A TERRA / FLOOR PROFILES / BODENPROFILE ▶ 106

xme627a

BX-6050 SET 4

L = 1500mm / L = 3000mm

DOCCIA CON SPALLA IN VETRO / CORNER SHOWER WITH 2 FIXED PANELS
ECKDUSCHE MIT 2 FESTSTEHENDEN GLASTAFELN

MY METALGLAS

€>BX.78

€KIT>BX.72

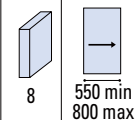

Fin. / Fin. / Oberf.

CR	IXE
Cromo lucido	Effetto inox satinato
Polished chrome	Inox effect
Chrom glänzend	Inox effekt

COMPONENTI / COMPONENTS / EINZELTEILE

BX-6050-C10 (2x)



BX-6050-C90(2x)
BX-6050-C81 (1x)



BX-6050-C70 (2x)



BX-6050-C30 (1x)



OPTIONAL

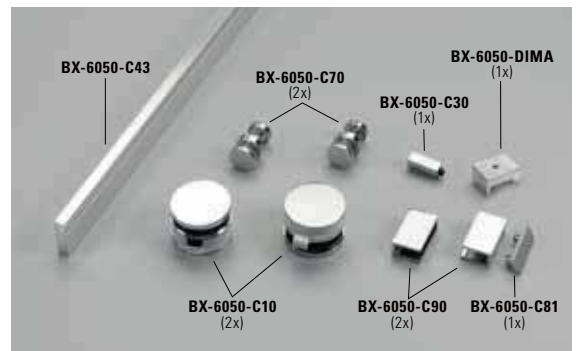
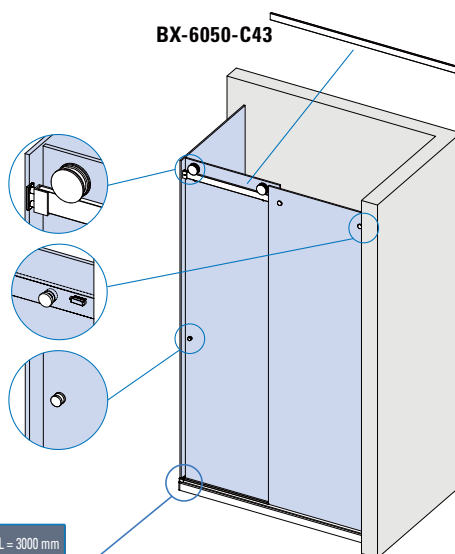

CARATTERISTICHE COMPONENTI /
FEATURES COMPONENTS /
EIGENSCHAFTEN EINZELTEILE ▶ 80

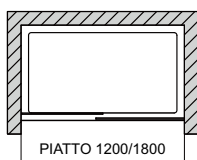
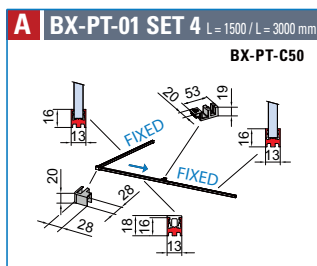

PROFILI A TERRA / FLOOR PROFILES / BODENPROFILE ▶ 106

xme627a

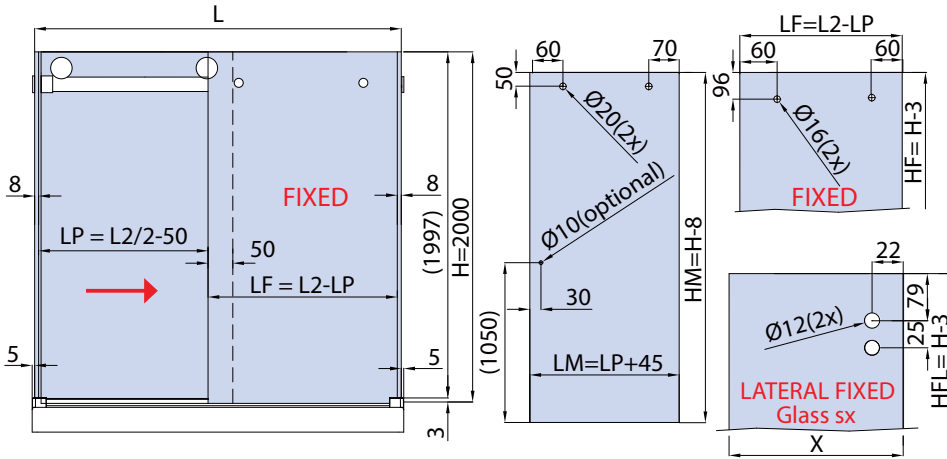
LAVORAZIONE VETRO / GLASS PREPARATION / GLASBEARBEITUNG

CALCOLO VETRO / CALCULATION GLASS / GLASBERECHNUNG

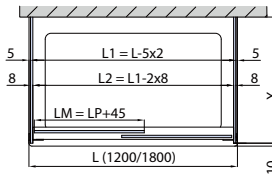
L = PIATTO - SHOWER TRAY - DUSCHTASSE
 L1=PIATTO (L)-5x2
 L2=L1-2x8
 Passaggio (LP) = L2 / 2 - 50
 Vetro Mobile Larghezza (LM) = LP + 45
 Vetro Fisso Larghezza (LF) = L2 - LP
 X = CALCOLARE / CALCULATE / BERECHNEN
 Vetro Mobile Altezza (HM) = H - 8 = 1992 mm

PROFILI A TERRA / FLOOR PROFILES / BODENPROFILE ▶ 106

BX-PT-01 STANDARD HF = H - 8 = 1992 mm HFL = H - 3

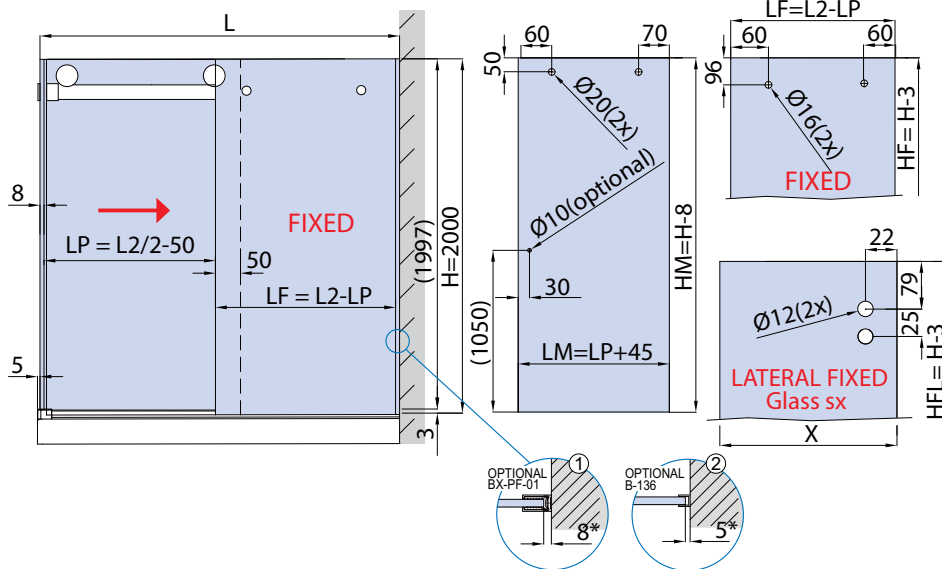
xme627c

CALCOLO VETRO / CALCULATION GLASS / GLASBERECHNUNG

L = PIATTO - SHOWER TRAY - DUSCHTASSE
 L1=PIATTO (L) - 5
 L2=L1 - 8
 Passaggio (LP) = L2 / 2 - 50
 Vetro Mobile Larghezza (LM) = LP + 45
 Vetro Fisso Larghezza (LF) = L2 - LP - * ① / * ② (aria variabile / clearance / Spaltmaß)
 X = CALCOLARE / CALCULATE / BERECHNEN
 Vetro Mobile Altezza (HM) = H - 8 = 1992mm

PROFILI A TERRA / FLOOR PROFILES / BODENPROFILE ▶ 106

BX-PT-01 STANDARD HF = H - 3 = 1997 mm

xme627c

SET 3 / SET 4

DA TAGLIARE / ADJUST THE LENGTH / BELIEBIG KÜRZBAR ✂

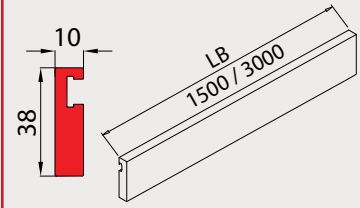

- Regolazione ± 3 mm.
- Adjustment ± 3 mm.
- Verstellung ± 3 mm.

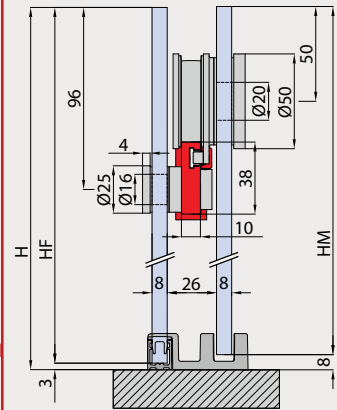

HM = H - 8
 HF = H - 3
 solo per / only for / nur für
BX-PT-01

OPTIONAL

L	LP	LM	LF	HM	HF	H
Piatto Shower tray Duschtaße	Passaggio luce Clear opening width Lichte Durchgangsbreite	Larghezza vetro mobile Sliding glass width Schiebeflügel Breite	Larghezza vetro fisso Side fixed glass width Seitenteil Breite	Altezza vetro mobile Sliding glass height Schiebeflügel Höhe	Altezza vetro fisso Side fixed glass height Seitenteil Höhe	Altezza doccia Shower height Duschkabine Höhe

BX-6050

COMPONENTI / COMPONENTS / EINZELTEILE

SCORREVOLI



BX-6050-C43/ BX-6050-C40

€ BX.82

- Binario
- Track profile
- Laufschiene

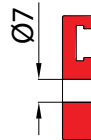
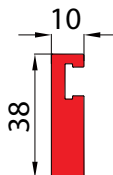

- Forature per fissaggio vetro fisso (ad opera dell'installatore con dima di foratura)
- Drilling for fixed glass by the installer (template included in Set)
- Bohrungen für Festverglasung bauseitig (Schablone im device Set enthalten)

Cod.	Fin. / Fin. / Oberf.
BX-6050-C43-1500 mm	CR / IXE
BX-6050-C43-3000 mm	CR / IXE
BX-6050-C40-1000 x 1000 mm (2 pcs)	CR / IXE

xme556i



BX-6050-C10

€ BX.83

- Ruota con antigancio
- Roller with antijump
- Laufrolle und Aushebeschutz

CR - NS

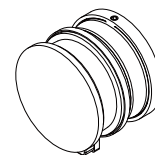
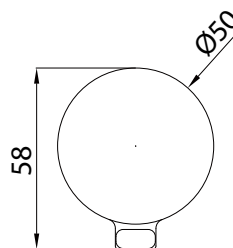
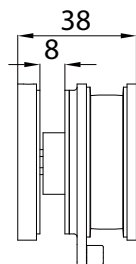

xme627d



BX-6050-C70

€ BX.84

- Punto di fissaggio vetro fisso al binario
- Fixing point for fixed glass and track profile
- Punkthalter für Fixierung des Festteils auf Laufschiene

CR - NS

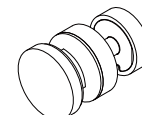
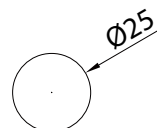
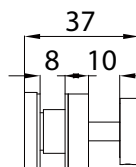

xme627d



BX-6050-C90 DX

€ BX.85

- Attacco a parete destro per binario
- Right wall connector for track profile
- Wandhalter rechts für Laufschiene

CR - NS

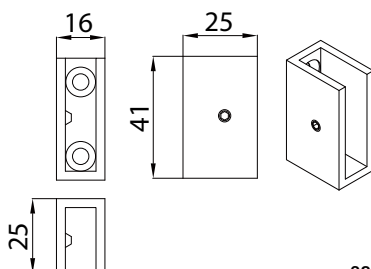

xme627d



BX-6050-C90 SX

€ BX.86

- Attacco a parete sinistro per binario
- Left wall connector for track profile
- Wandhalter links für Laufschiene

CR - NS

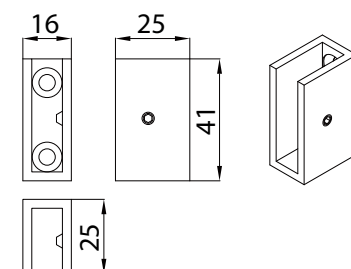

xme627d

BX-6050-C30 € BX.87

- Stopper
- CR - NS

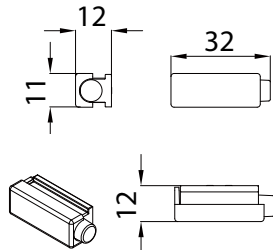

xme627d

BX-6050-C20 € BX.89

- Connettore ad angolo per binari set 1
- Corner connector for track profiles set 1
- Winkelverbinder Laufschiene set 1
- CR - NS

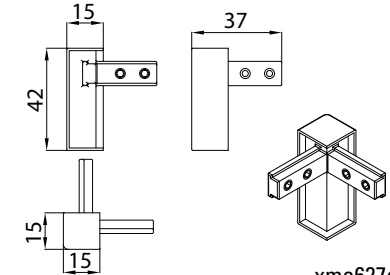

xme627d

BX-6050-C81 € BX.88

- Piastrina attacco a vetro per BX-6050-C90
- Plate glass connector for BX-6050-C90
- Platte Glashalter für BX-6050-C90
- CR - NS

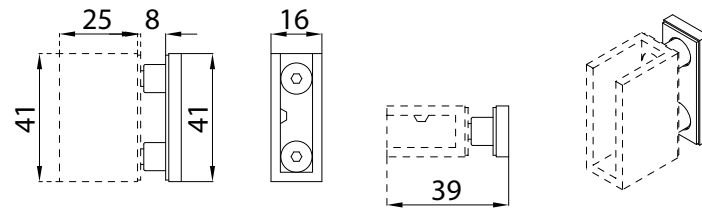

xme627d

BX-PT-C50 € BX.91

- Guida vetro scorrevole per applicazione con profilo a terra.
- Floor guide sliding panel for installation with floor profile.
- Schiebetür Bodenführung für Montage mit Bodenprofile.
- CR - NS

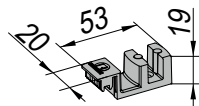
BX-6050-DIMA € BX.90

- Dima per foratura per morsetto vetro fisso
- Template for drilling the track profile with the clamp
- Schablone für das Bohren der Laufschiene mit der Klemme

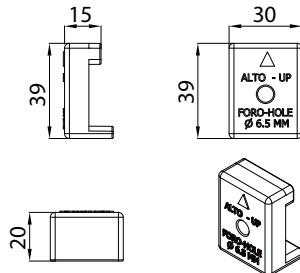

xme627d

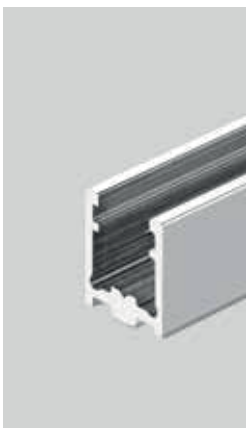
BX-PT-C58 € BX.144

- Profilo per fissaggio a terra o laterale
- Profile for floor and side installation
- Profil Boden- Wandmontage

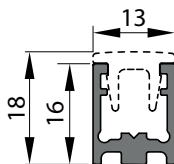

Cod.	Fin./Fin./Fin.
BX-PT-C58-1500 mm	CR / IXE
BX-PT-C58-3000 mm	CR / IXE

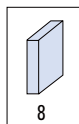
BX-PT-C56 € BX.145

- Coperchio per profilo a terra per tratto entrata doccia
- Cover profile for floor profile, shower entry.
- Profilabdeckung Bodenprofil Duscheinstieg

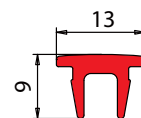

Cod.	Fin./Fin./Fin.
BX-PT-C56-1500 mm	CR / IXE
BX-PT-C56-3000 mm	CR / IXE

VISTA ESTERNA
EXTERNAL VIEW



SCORREVOLI

VISTA INTERNA
INTERNAL VIEW



BX-6000 ETEREA

VEDRAI L'USUALE CON OCCHI DIVERSI

Con Eterea ci siamo accorti che per noi innovare è consuetudine. Volevamo semplificare un prodotto classico per renderlo il più possibile minimale, bello ed accattivante, ed alla fine abbiamo fatto "scompare tutto".

PER IL SUO DESIGN E PER L'INNOVAZIONE CHE LA CONTRADDISTINGUE ETEREA SI CANDIDA AD ESSERE LA MIGLIORE SUL MERCATO.

YOU WILL SEE THE USUAL WITH DIFFERENT EYES

With Eterea we realised that it is customary for us to innovate. We set out to simplify a classic product to make it as minimal, beautiful and as alluring as possible, and ultimately we made "everything disappear". Due to its design and the innovation that distinguishes it, Eterea boasts it is the best on the market.

SIE WERDEN DAS NORMALE MIT ANDEREN AUGEN BETRACHTEN

Mit Eterea haben wir bemerkt, dass Innovation für uns üblich ist. Wir wollten ein klassisches Produkt vereinfachen, um es möglichst minimal zu gestalten, schön und attraktiv, und schließlich haben wir „alles verschwinden lassen“. Aufgrund des herausragenden Designs und der Innovation konkurriert Eterea, um die Beste auf dem Markt zu werden.

BOX DOCCIA MODELLO TRADIZIONALE

TRADITIONAL SHOWER ENCLOSURE MODEL
TRADITIONELLES DUSCHKABINEMODELL

INVISIBILE IN
ETEREA
BX-6000

INVISIBILE IN ETEREA BX-6000
UNSICHTBAR ETEREA BX-6000



SCORREVOLI

PLUS

- NESSUNO STOPPER A VISTA
- NESSUNA BORCHIA PER L'AGGANCIAMENTO DEL VETRO FISSO A VISTA
- SISTEMA ANTISOLLEVAMENTO DI SICUREZZA INVISIBILE
- SISTEMA OPZIONALE DI CHIUSURA "SOFT-CLOSE"
- SISTEMA STANDARD DI CHIUSURA AMMORTIZZATA
- PROFILO INTERNO DOCCIA PRIVO DI ACCESSORI A VISTA

- No visible stopper
- No visible fixing point on the fixed glass panel
- Invisible safety anti-lift system
- Optional soft-close closing system.
- Standard cushioned closing system
- Shower internal profile without visible accessories

- Kein sichtbarer Stopper
- Keine sichtbare Befestigungspunkte zum fixieren des Glases
- Unsichtbares Aushebeschutzsystem
- Ein optionales Schließsystem soft-close.
- Ein gedämpftes Standard-Schließsystem
- Innenprofil der Dusche ohne sichtbares Zubehör

BX-6000 / BX-6020 SOFT-CLOSE



- Profilo completamente libero e semplificazione della pulizia, quindi eliminazione totale di depositi e residui dovuti al normale utilizzo. Costruita in alluminio è disponibile nelle finiture cromo lucido e nero opaco.
- A completely free profile also means simplification of cleaning, therefore complete elimination of deposits and residues due to normal use. Made of aluminium, it is available in polished chrome and matt black finishes.
- Ein vollständig freies Profil bedeutet auch vereinfachte Reinigung, daher werden Ablagerungen und Rückstände durch normalen Gebrauch komplett beseitigt. Hergestellt aus Aluminium und ist mit Oberflächen in Chrom glänzend und matt schwarz erhältlich.



SCOREVOLI



SET 1 €► BX.92
€► BX.98

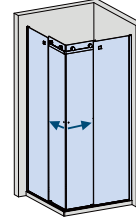

SET 2 €► BX.93
€► BX.99

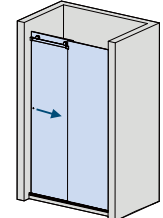

SET 3 €► BX.94
€► BX.100

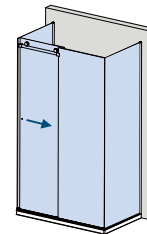

SET 4 €► BX.95
€► BX.101

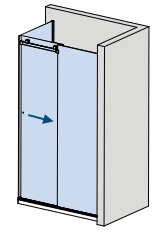

SET 5 €► BX.96
€► BX.102

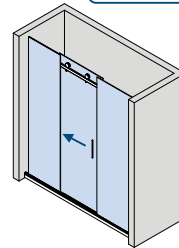

SCORREVOLI

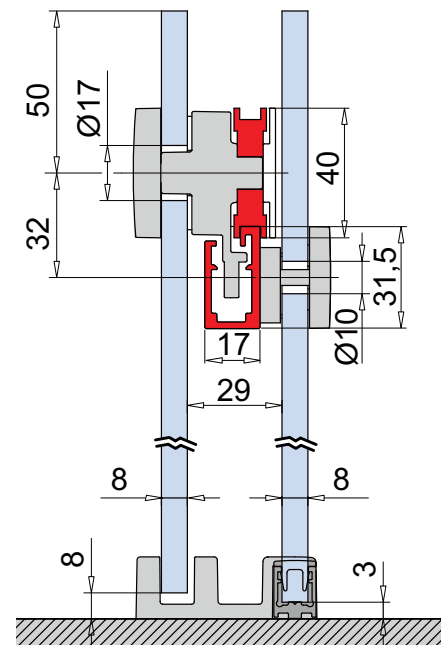

BX-6000 SET 1

L = 1000 x 1000mm

DOCCIA IN ANGOLO / CORNER SHOWER / ECKDUSCHE

MY METALGLAS

€ ▶ BX.92

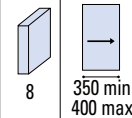

Fin. / Fin. / Oberf.

CR	NO
Cromo lucido	Nero opaco
Polished chrome	Matt black
Chrom glänzend	Matt schwarz

COMPONENTI / COMPONENTS / EINZELTEILE

- BX-6000-C30 (2x)
- BX-6000-C10 (4x)
- BX-6000-C90 (2x)
- BX-6000-C70-2 (2x)
- BX-6000-C20 (1x)
- OPTIONAL B-136/BX-PF-01 (1x)
- OPTIONAL

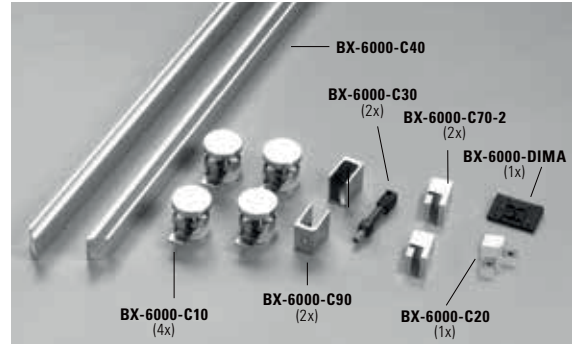
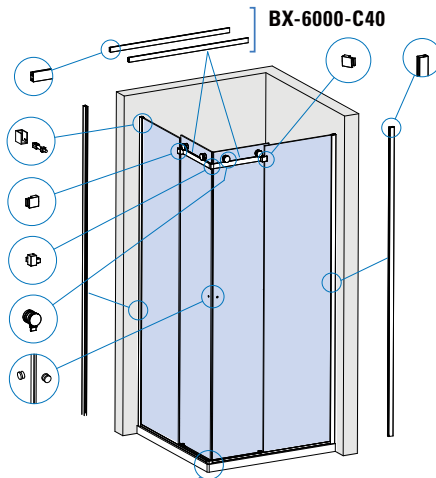

CARATTERISTICHE COMPONENTI / FEATURES COMPONENTS / EIGENSCHAFTEN EINZELTEILE ▶ 94

- Obbligatorio fissaggio a parete tramite profili a "U" o morsetti (non inclusi)
- Necessary wall-mounting with "U" profiles or clamps (not included)
- Verbindliche Befestigung an der Wand mit „U“-Profilen oder Wandhaltern (nicht inbegriffen)

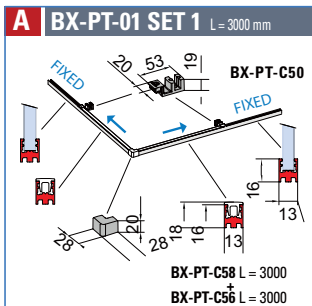
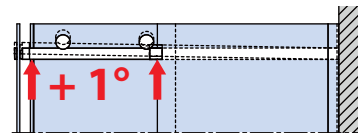

PROFILI A TERRA / FLOOR PROFILES / BODENPROFILE ▶ 106

BX-6020 SOFT-CLOSE SET 1

L = 1000 x 1000mm

DOCCIA IN ANGOLO / CORNER SHOWER / ECKDUSCHE

MY METALGLAS

€ ▶ BX.98

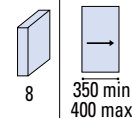

Fin. / Fin. / Oberf.

CR	NO
Cromo lucido	Nero opaco
Polished chrome	Matt black
Chrom glänzend	Matt schwarz

COMPONENTI / COMPONENTS / EINZELTEILE

- BX-6000-SOFT-CLOSE (2x)
- BX-6000-C10 (2x)
- BX-6000-C12 (2x)
- BX-6000-C90 (2x)
- BX-6000-C70-1 (2x)
- BX-6000-C20 (1x)
- OPTIONAL B-136/BX-PF-01 (1x)
- OPTIONAL

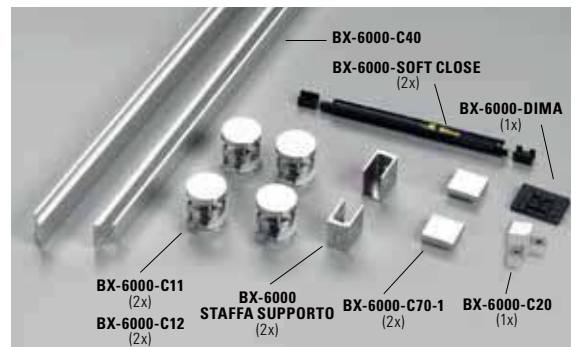
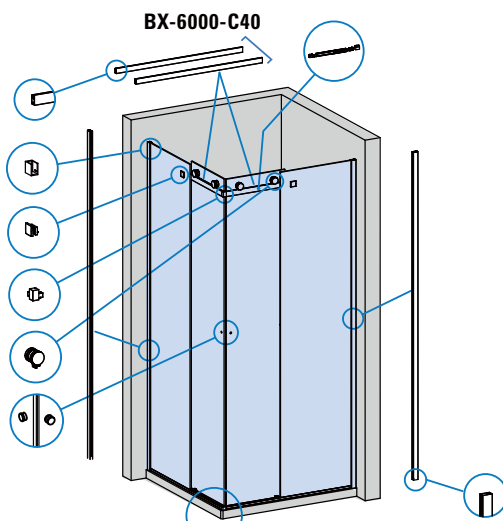

CARATTERISTICHE COMPONENTI / FEATURES COMPONENTS / EIGENSCHAFTEN EINZELTEILE ▶ 94

- Obbligatorio fissaggio a parete tramite profili a "U" o morsetti (non inclusi)
- Necessary wall-mounting with "U" profiles or clamps (not included)
- Verbindliche Befestigung an der Wand mit „U“-Profilen oder Wandhaltern (nicht inbegriffen)

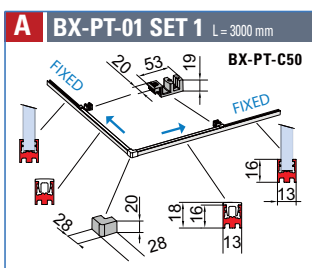
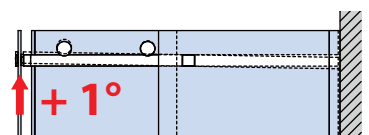

PROFILI A TERRA / FLOOR PROFILES / BODENPROFILE ▶ 106

SCORREVOLI

LAVORAZIONE VETRO / GLASS PREPARATION / GLASBEARBEITUNG

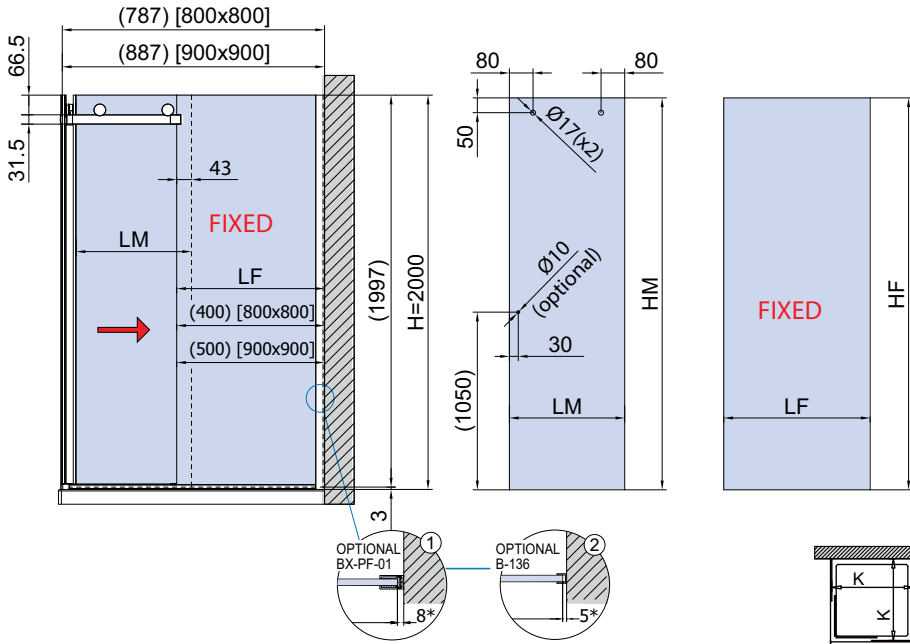

CALCOLO VETRO / CALCULATION GLASS / GLASBERECHNUNG

PIATTO - SHOWER TRAY - DUSCHASSE (L) = 800x800 (900x900) mm

Vetro Mobile Larghezza (LM) = L / 2

Vetro Fisso Larghezza (LF) = [(L / 2)] - * ① / * ② (aria variabile / clearance / Spaltmaß)

Vetro Mobile Altezza (HM) = H - 8 = 1992 mm

PROFILI A TERRA / FLOOR PROFILES / BODENPROFILE ▶ 106

A BX-PT-01 STANDARD HF = H - 3 = 1997 mm

xme556a

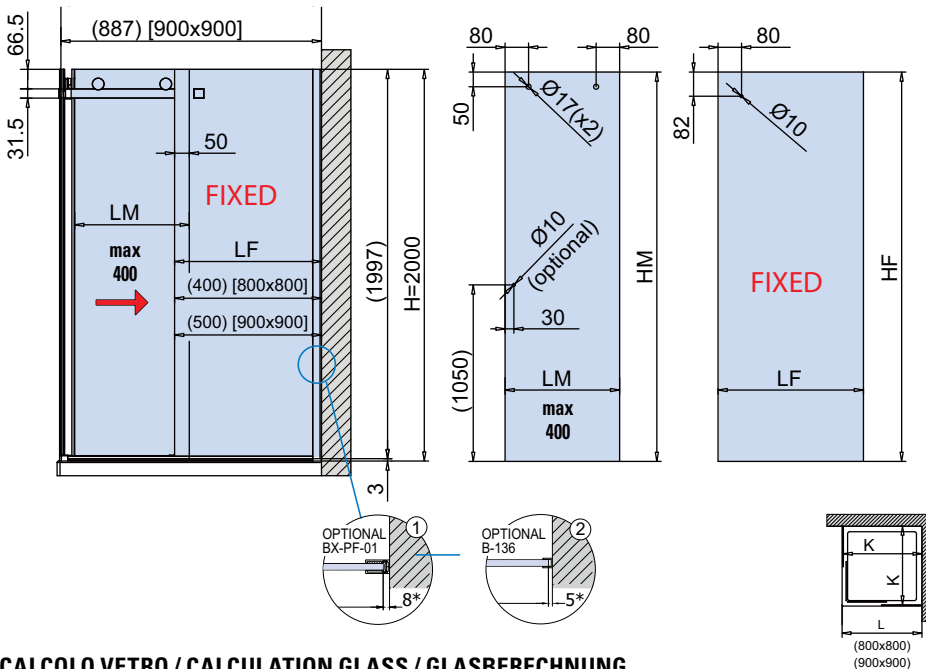

CALCOLO VETRO / CALCULATION GLASS / GLASBERECHNUNG

PIATTO - SHOWER TRAY - DUSCHASSE (L) = 800x800 (900x900) mm

Vetro Mobile Larghezza (LM) = L / 2

Vetro Fisso Larghezza (LF) = [(L / 2)] - * ① / * ② (aria variabile / clearance / Spaltmaß)

Vetro Mobile Altezza (HM) = H - 8 = 1992 mm

PROFILI A TERRA / FLOOR PROFILES / BODENPROFILE ▶ 106

A BX-PT-01 STANDARD HF = H - 3 = 1997 mm

xme556b

SET 1

DA TAGLIARE / ADJUST THE LENGTH /
BELIEBIG KÜRZBAR ✂

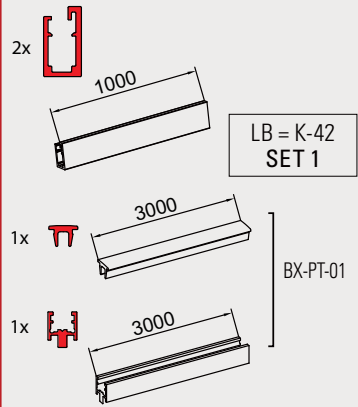

- Regolazione ± 2 mm.
- Adjustment ± 2 mm.
- Verstellung ± 2 mm.

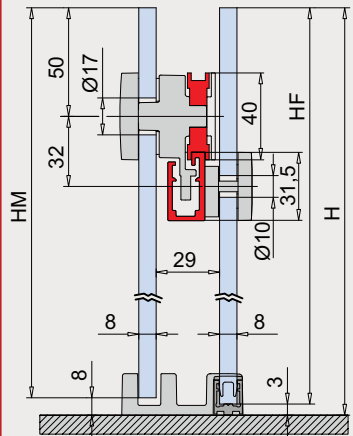

HM = H - 8
 HF = H - 3
 solo per / only for / nur für
A BX-PT-01

OPTIONAL



L	LP	LM	LF	HM	HF	H
Piatto Shower tray Duschasse	Passaggio luce Clear opening width Lichte Durchgangsbreite	Larghezza vetro mobile Sliding glass width Schiebeflügel Breite	Larghezza vetro fisso Side fixed glass width Seitenteil Breite	Altezza vetro mobile Sliding glass height Schiebeflügel Höhe	Altezza vetro fisso Side fixed glass height Seitenteil Höhe	Altezza doccia Shower height Duschkabine Höhe

BX-6000 SET 2 DX / BX-6000 SET 2 SX

L = 1500mm / L = 3000mm
DOCCIA IN NICCHIA / NICHE SHOWER / NISCHENDUSCHE

MY METALGLAS

€ BX.93

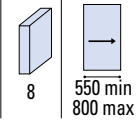

Fin. / Fin. / Oberf.	
CR	NO
Cromo lucido	Nero opaco
Polished chrome	Matt black
Chrom glänzend	Matt schwarz

COMPONENTI / COMPONENTS / EINZELTEILE

- BX-6000-C30** (1x)
- BX-6000-C10** (2x)
- BX-6000-C90** (2x)
- BX-6000-C70-2** (1x)
- OPTIONAL**
B-136/BX-PF-01 (1x)
- OPTIONAL**

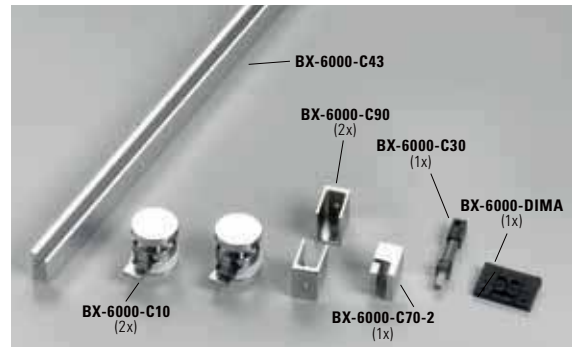
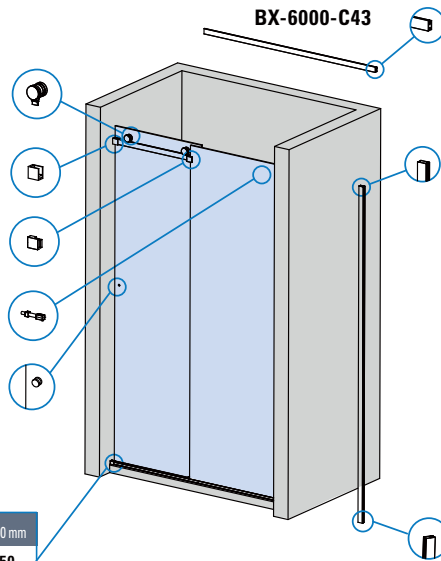

CARATTERISTICHE COMPONENTI / FEATURES COMPONENTS / EIGENSCHAFTEN EINZELTEILE ▶ 94



- Obbligatorio fissaggio a parete tramite profili a "U" o morsetti (non inclusi)
- Necessary wall-mounting with "U" profiles or clamps (not included)
- Verbindliche Befestigung an der Wand mit „U“-Profilen oder Wandhaltern (nicht inbegriffen)

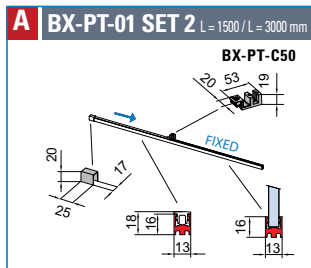

PROFILI A TERRA / FLOOR PROFILES / BODENPROFILE ▶ 106

xme556c

BX-6020 SOFT-CLOSE SET 2

L = 1500mm / L = 3000mm
DOCCIA IN NICCHIA / NICHE SHOWER / NISCHENDUSCHE

MY METALGLAS

€ BX.99

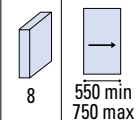

Fin. / Fin. / Oberf.	
CR	NO
Cromo lucido	Nero opaco
Polished chrome	Matt black
Chrom glänzend	Matt schwarz

COMPONENTI / COMPONENTS / EINZELTEILE

- BX-6000-SOFT-CLOSE** (1x)
- BX-6000-C11** (1x)
- BX-6000-C12** (1x)
- BX-6000-C90** (2x)
- BX-6000-C70-1** (1x)
- OPTIONAL**
B-136/BX-PF-01 (1x)
- OPTIONAL**

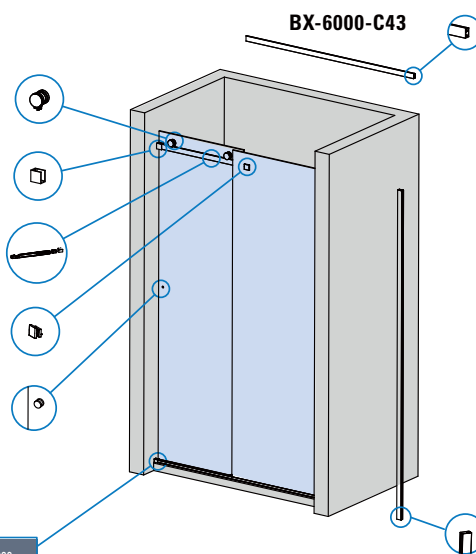

CARATTERISTICHE COMPONENTI / FEATURES COMPONENTS / EIGENSCHAFTEN EINZELTEILE ▶ 94

- Obbligatorio fissaggio a parete tramite profili a "U" o morsetti (non inclusi)
- Necessary wall-mounting with "U" profiles or clamps (not included)
- Verbindliche Befestigung an der Wand mit „U“-Profilen oder Wandhaltern (nicht inbegriffen)

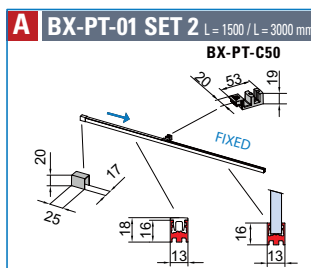

PROFILI A TERRA / FLOOR PROFILES / BODENPROFILE ▶ 106

xme556d

SCORREVOLI

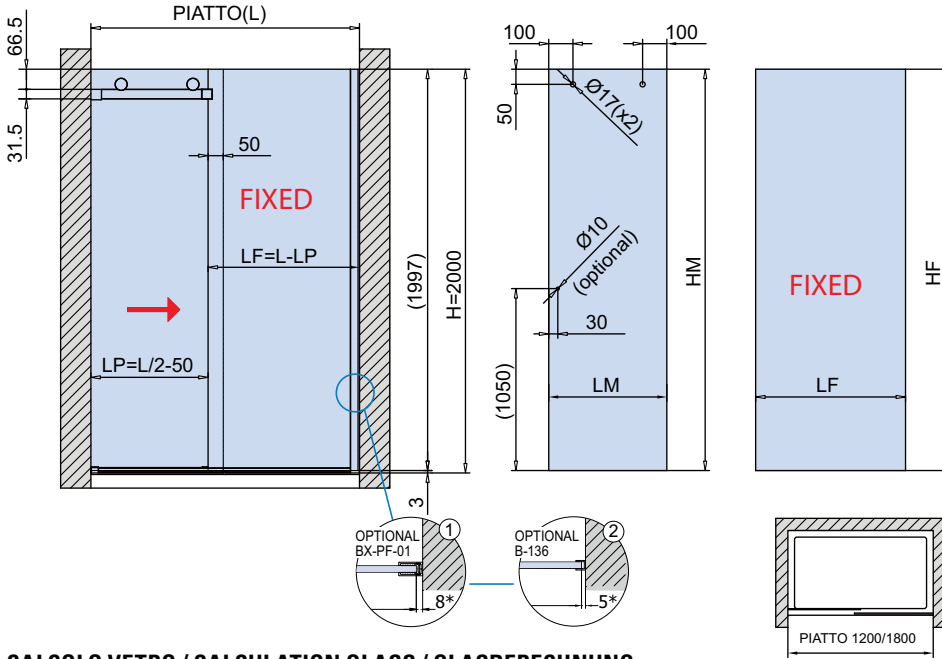
LAVORAZIONE VETRO / GLASS PREPARATION / GLASBEARBEITUNG

CALCOLO VETRO / CALCULATION GLASS / GLASBERECHNUNG

L = PIATTO - SHOWER TRAY - DUSCHTASSE

Passaggio (LP) = L / 2 - 50

Vetro Mobile Larghezza (LM) = LP + 45

Vetro Fisso Larghezza (LF) = L - LP - * (1) / * (2) (aria variabile / clearance / Spaltmaß)

Vetro Mobile Altezza (HM) = H - 8 = 1992 mm

PROFILI A TERRA / FLOOR PROFILES / BODENPROFILE ▶ 106
BX-PT-01 STANDARD HF = H - 3 = 1997 mm

xme556c

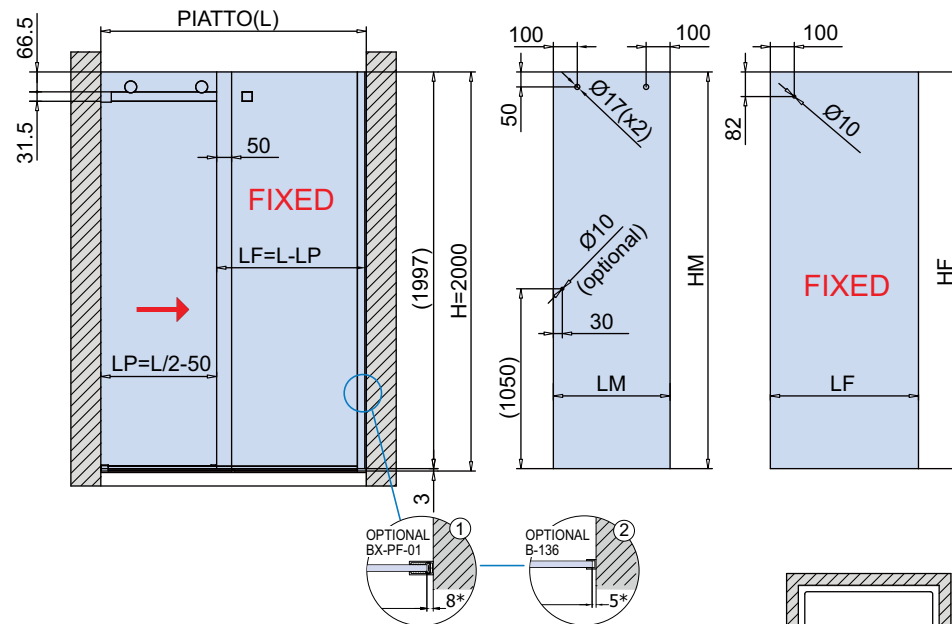
CALCOLO VETRO / CALCULATION GLASS / GLASBERECHNUNG

L = PIATTO - SHOWER TRAY - DUSCHTASSE

Passaggio (LP) = L / 2 - 50

Vetro Mobile Larghezza (LM) = LP + 45

Vetro Fisso Larghezza (LF) = L - LP - * (1) / * (2) (aria variabile / clearance / Spaltmaß)

Vetro Mobile Altezza (HM) = H - 8 = 1992 mm

PROFILI A TERRA / FLOOR PROFILES / BODENPROFILE ▶ 106
BX-PT-01 STANDARD HF = H - 3 = 1997 mm

xme556d

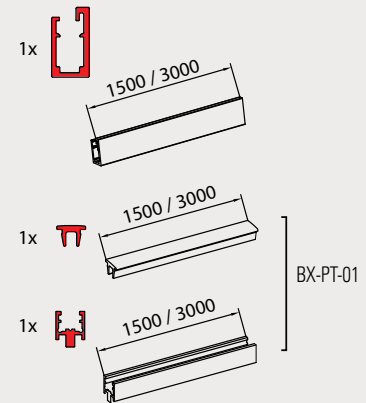
SET 2
DA TAGLIARE / ADJUST THE LENGTH / BELIEBIG KÜRZBAR ✂

- Regolazione ± 2 mm.
- Adjustment ± 2 mm.
- Verstellung ± 2 mm.

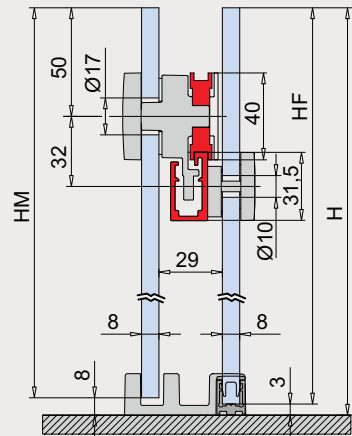
OPTIONAL

L	LP	LM	LF	HM	HF	H	HFL
PIATTO Shower tray Duschtaße	Passaggio luce Clear opening width Lichte Durchgangsbreite	Larghezza vetro mobile Sliding glass width Schiebefügel Breite	Larghezza vetro fisso Side fixed glass width Seitenteil Breite	Altezza vetro mobile Sliding glass height Schiebefügel Höhe	Altezza vetro fisso Side fixed glass height Seitenteil Höhe	Altezza doccia Shower height Duschkabine Höhe	Altezza vetro fisso laterale Side fixed glass height Seitenteil (seitlich) Höhe

BX-6000 SET 3 DX / BX-6000 SET 3 SX

MY METALGLAS

L = 1500mm / L = 3000mm

DOCCIA A U / U SHOWER / U DUSCHE

€ ▶ BX.94

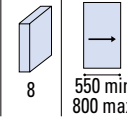

Fin. / Fin. / Oberf.

CR	NO
Cromo lucido	Nero opaco
Polished chrome	Matt black
Chrom glänzend	Matt schwarz

COMPONENTI / COMPONENTS / EINZELTEILE

- BX-6000-C30** (1x)
- BX-6000-C10** (2x)
- BX-6000-C90** (2x)
- BX-6000-C81** (2x)
- BX-6000-C70-2** (1x)
- BX-6000-C70-1** (1x)
- OPTIONAL**
B-136/BX-PF-01 (1x)
- OPTIONAL**

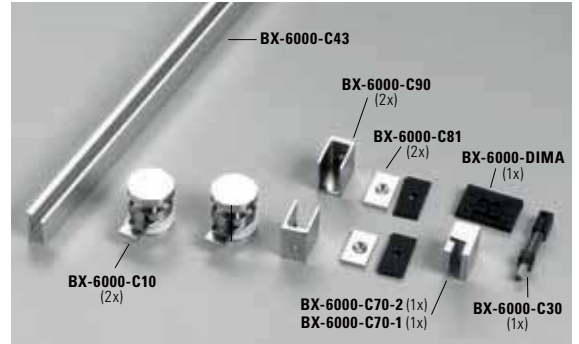
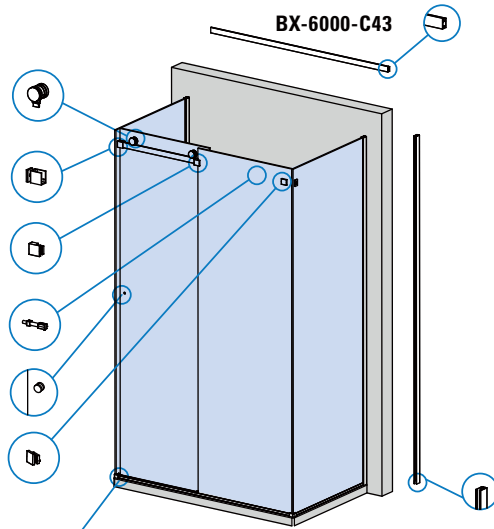

CARATTERISTICHE COMPONENTI /
FEATURES COMPONENTS /
EIGENSCHAFTEN EINZELTEILE ▶ 94

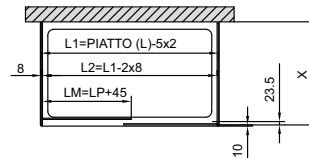
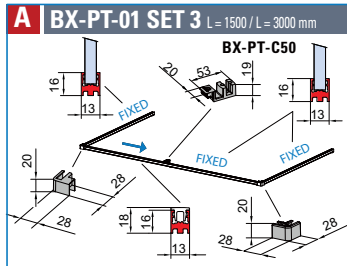

PROFILI A TERRA / FLOOR PROFILES / BODENPROFILE ▶ 106

xme556e

- Obbligatorio fissaggio a parete tramite profili a "U" o morsetti (non inclusi)
- Necessary wall-mounting with "U" profiles or clamps (not included)
- Verbindliche Befestigung an der Wand mit „U“-Profilen oder Wandhaltern (nicht inbegriffen)

BX-6020 SOFT-CLOSE SET 3



MY METALGLAS

L = 1500mm / L = 3000mm

DOCCIA A U / U SHOWER / U DUSCHE

€ ▶ BX.100

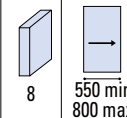

Fin. / Fin. / Oberf.

CR	NO
Cromo lucido	Nero opaco
Polished chrome	Matt black
Chrom glänzend	Matt schwarz

COMPONENTI / COMPONENTS / EINZELTEILE

- BX-6000-SOFT-CLOSE** (1x)
- BX-6000-C11** (1x)
- BX-6000-C12** (1x)
- BX-6000-C90** (2x)
- BX-6000-C81** (2x)
- BX-6000-C70-1** (2x)
- OPTIONAL**
B-136/BX-PF-01 (2x)
- OPTIONAL**

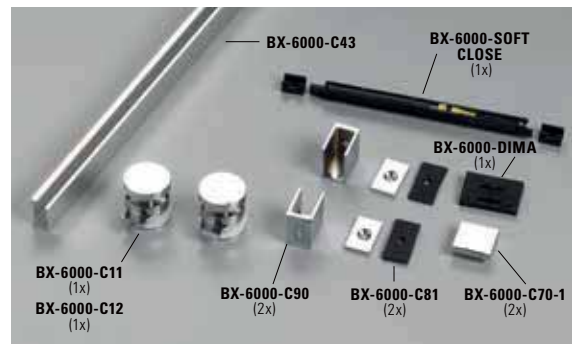
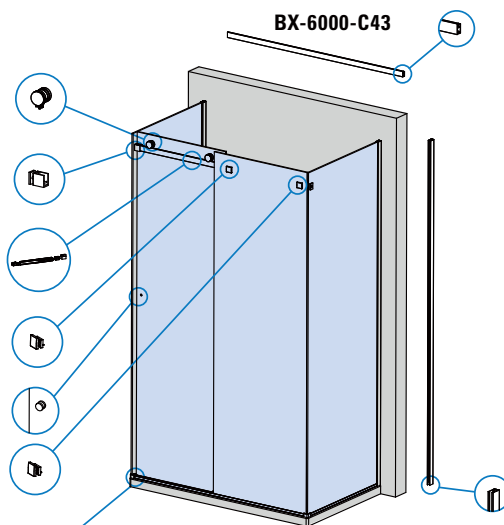

CARATTERISTICHE COMPONENTI /
FEATURES COMPONENTS /
EIGENSCHAFTEN EINZELTEILE ▶ 94

- Obbligatorio fissaggio a parete tramite profili a "U" o morsetti (non inclusi)
- Necessary wall-mounting with "U" profiles or clamps (not included)
- Verbindliche Befestigung an der Wand mit „U“-Profilen oder Wandhaltern (nicht inbegriffen)

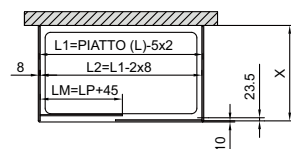
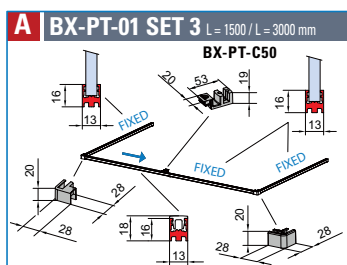

PROFILI A TERRA / FLOOR PROFILES / BODENPROFILE ▶ 106

xme556f

LAVORAZIONE VETRO / GLASS PREPARATION / GLASBEARBEITUNG

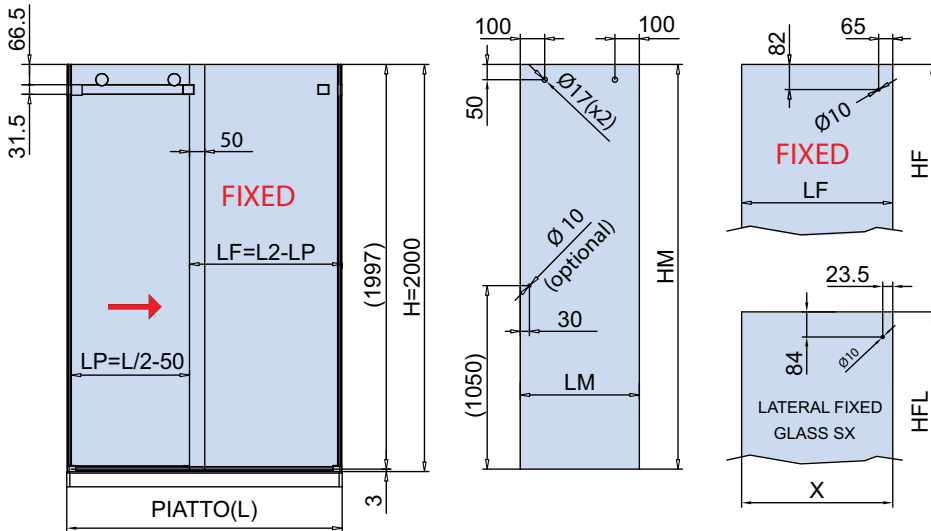

CALCOLO VETRO / CALCULATION GLASS / GLASBERECHNUNG

L = PIATTO - SHOWER TRAY - DUSCHTASSE

L1=PIATTO (L)-5x2

L2=L1-2x8

Passaggio (LP) = L2 / 2 - 50

Vetro Mobile Larghezza (LM) = LP + 45

Vetro Fisso Larghezza (LF) = L2 - LP

X = CALCOLARE / CALCULATE / BERECHNEN

Vetro Mobile Altezza (HM) = H - 8 = 1992 mm

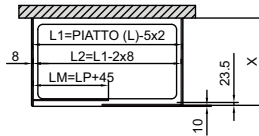

PROFILI A TERRA / FLOOR PROFILES / BODENPROFILE ▶ 106

A BX-PT-01 STANDARD HF = H - 3 = 1997 mm HFL = H - 3

xme556e

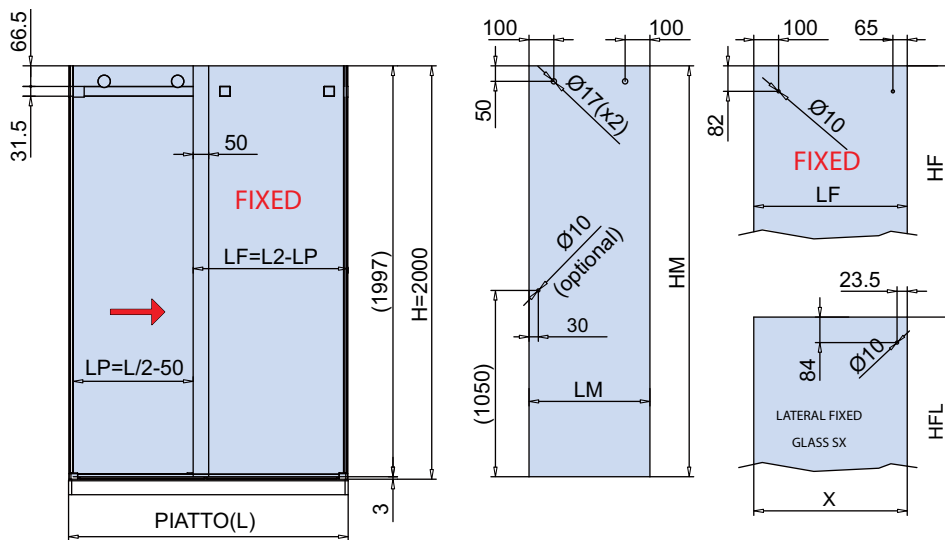

CALCOLO VETRO / CALCULATION GLASS / GLASBERECHNUNG

L = PIATTO - SHOWER TRAY - DUSCHTASSE

L1 = PIATTO (L)-5x2

L2 = L1-2x8

Passaggio (LP) = L2 / 2 - 50

Vetro Mobile Larghezza (LM) = LP + 45

Vetro Fisso Larghezza (LF) = L2 - LP

X = CALCOLARE / CALCULATE / BERECHNEN

Vetro Mobile Altezza (HM) = H - 8 = 1992 mm

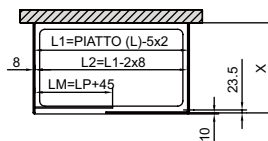

PROFILI A TERRA / FLOOR PROFILES / BODENPROFILE ▶ 106

A BX-PT-01 STANDARD HF = H - 3 = 1997 mm HFL = H - 3

xme556f

SET 3

DA TAGLIARE / ADJUST THE LENGTH / BELIEBIG KÜRZBAR ✂

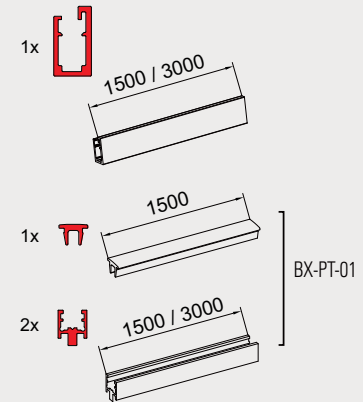

- Regolazione ± 2 mm.
- Adjustment ± 2 mm.
- Verstellung ± 2 mm.

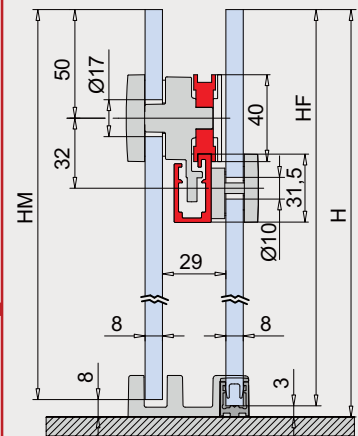

HM = H - 8
HF = H - 3
solo per / only for / nur für
A BX-PT-01

OPTIONAL



L	LP	LM	LF	HM	HF	H	HFL
Piatto Shower tray Duschtaße	Passaggio luce Clear opening width Lichte Durchgangsbreite	Larghezza vetro mobile Sliding glass width Schiebeflügel Breite	Larghezza vetro fisso Side fixed glass width Seitenteil Breite	Altezza vetro mobile Sliding glass height Schiebeflügel Höhe	Altezza vetro fisso Side fixed glass height Seitenteil Höhe	Altezza doccia Shower height Duschkabine Höhe	Altezza vetro fisso laterale Side fixed glass height Seitenteil (seitlich) Höhe

SCORREVOLI

BX-6000 SET 4 DX / BX-6000 SET 4 SX

MY METALGLAS

L = 1500mm / L = 3000mm

DOCCIA CON SPALLA IN VETRO / CORNER SHOWER WITH 2 FIXED PANELS
ECKDUSCHE MIT 2 FESTSTEHENDEN GLASTAFELN

€ ▶ BX.95

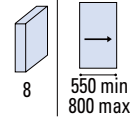

Fin. / Fin. / Oberf.

CR	NO
Cromo lucido	Nero opaco
Polished chrome	Matt black
Chrom glänzend	Matt schwarz

COMPONENTI / COMPONENTS / EINZELTEILE

- BX-6000-C30 (1x)
- BX-6000-C10 (2x)
- BX-6000-C90 (1x)
BX-6000-C81 (1x)
- BX-6000-C70-2 (1x)
- BX-6000-C70-1 (1x)
- OPTIONAL
B-136/BX-PF-01 (2x)
- OPTIONAL

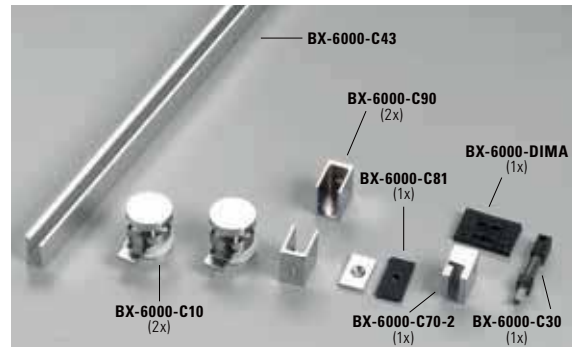
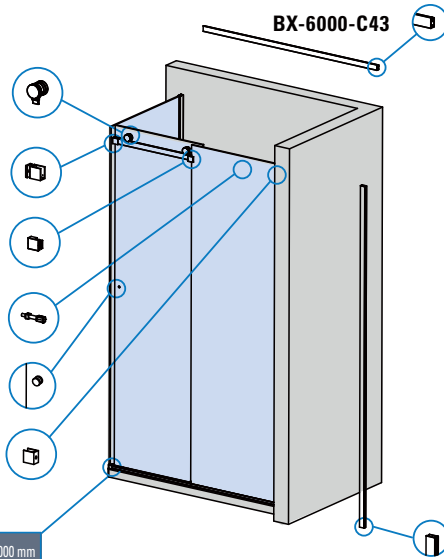

CARATTERISTICHE COMPONENTI /
FEATURES COMPONENTS /
EIGENSCHAFTEN EINZELTEILE ▶ 94



- Obbligatorio fissaggio a parete tramite profili a "U" o morsetti (non inclusi)
- Necessary wall-mounting with "U" profiles or clamps (not included)
- Verbindliche Befestigung an der Wand mit „U“-Profilen oder Wandhaltern (nicht inbegriffen)

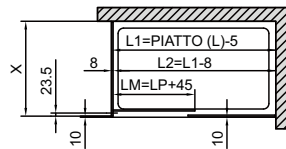
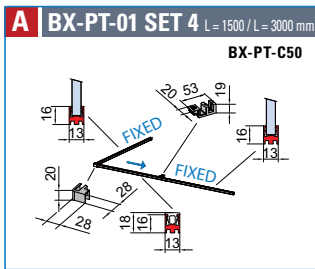

PROFILI A TERRA / FLOOR PROFILES / BODENPROFILE ▶ 106

xme556g

BX-6020 SOFT-CLOSE SET 4



MY METALGLAS

L = 1500mm / L = 3000mm

DOCCIA CON SPALLA IN VETRO / CORNER SHOWER WITH 2 FIXED PANELS
ECKDUSCHE MIT 2 FESTSTEHENDEN GLASTAFELN

€ ▶ BX.101

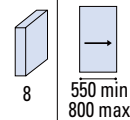

Fin. / Fin. / Oberf.

CR	NO
Cromo lucido	Nero opaco
Polished chrome	Matt black
Chrom glänzend	Matt schwarz

COMPONENTI / COMPONENTS / EINZELTEILE

- BX-6000-SOFT-CLOSE (1x)
- BX-6000-C11 (1x)
BX-6000-C12 (1x)
- BX-6000-C90 (1x)
BX-6000-C81 (1x)
- BX-6000-C90 (1x)
- BX-6000-C70-1 (1x)
- OPTIONAL
B-136/BX-PF-01 (2x)
- OPTIONAL

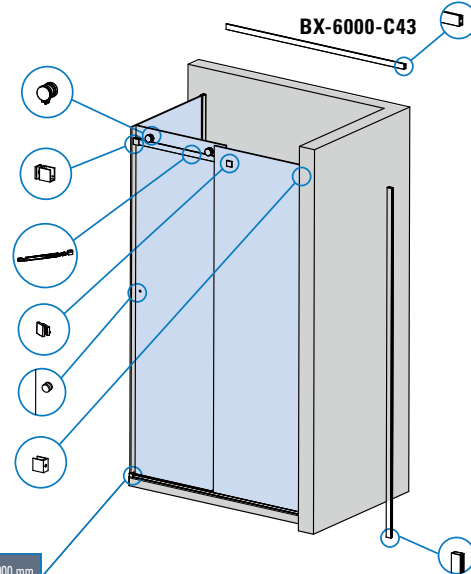

CARATTERISTICHE COMPONENTI /
FEATURES COMPONENTS /
EIGENSCHAFTEN EINZELTEILE ▶ 94

- Obbligatorio fissaggio a parete tramite profili a "U" o morsetti (non inclusi)
- Necessary wall-mounting with "U" profiles or clamps (not included)
- Verbindliche Befestigung an der Wand mit „U“-Profilen oder Wandhaltern (nicht inbegriffen)

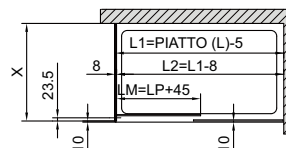
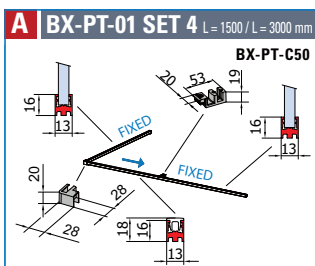

PROFILI A TERRA / FLOOR PROFILES / BODENPROFILE ▶ 106

xme556h

BX-6000 / BX-6020 SOFT-CLOSE

COMPONENTI / COMPONENTS / EINZELTEILE

SCORREVOLI



BX-6000-C43/ BX-6000-C40

- Binario
- Track profile
- Laufschiene

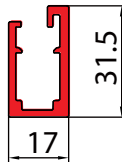

Cod.	Fin. / Fin. / Oberf.
BX-6000-C43-1500 mm	CR / NO
BX-6000-C43-3000 mm	CR / NO
BX-6000-C40-1000 x 1000 mm (2 pcs)	CR / NO

€ BX.104

xme556i



BX-6000-C10

- Ruota con antigancio per set **senza** soft-close
- Roller with antijump for sets **without** soft-close
- Laufrolle und Aushebeschutz für sets **ohne** soft-close

CR - NO

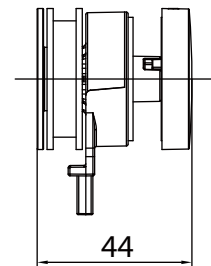
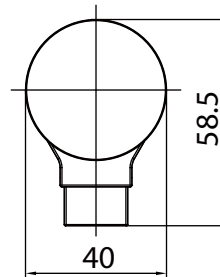

€ BX.105

xme556i



BX-6000-C11

- Ruota con attivatore per versione soft-close
- Roller with antijump and soft-close activator
- Laufrolle mit Aushebeschutz und soft-close Mitnehmer

CR - NO

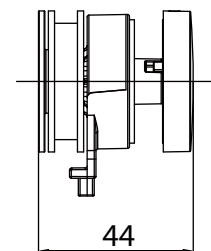
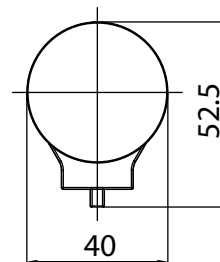

€ BX.106

xme556i



BX-6000-C12

- Ruota con antigancio per versioni soft-close
- Roller with antijump for soft-close sets
- Laufrolle mit Aushebeschutz für soft-close sets

CR - NO

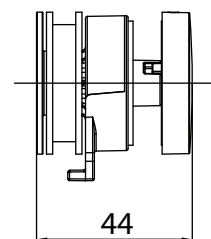
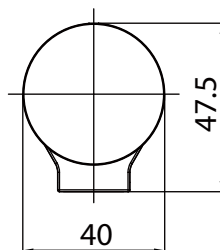

€ BX.107

xme556i

BX-6000-C70-2 DX (destra - right - rechts)
BX-6000-C70-2 SX (sinistra - left - links)

- Morsetto vetro fisso per tutti i set versione senza soft-close
 - Fixed glass clamp for all sets without soft-close
 - Klemme für Seitenteil für alle sets ohne soft-close
- CR - NO

€ BX.108
 € BX.109

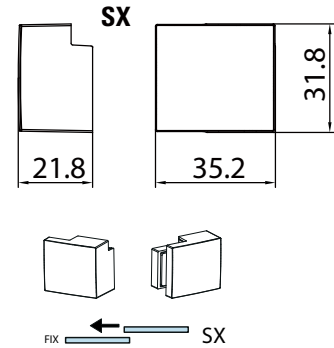
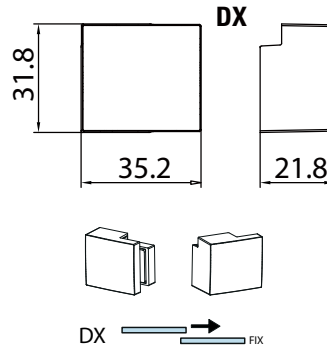

xme556i

SCORREVOLI

BX-6000-C30
 • Stopper

€ BX.115

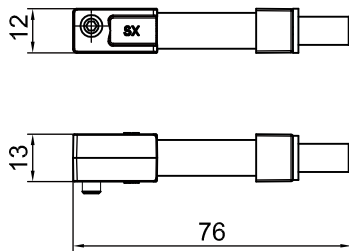

xme556i

BX-6000-C70-1

€ BX.110

- Morsetto vetro fisso per tutti i set versione con soft-close e per set 3 senza soft-close
 - Fixed glass clamp for all sets with soft-close and for set 3 without soft-close
 - Klemme für Seitenteil für alle sets mit soft-close und für set 3 ohne soft-close
- CR - NO



xme556i

BX-6000-C90 DX

- Attacco a parete destro per binario
 - Right wall connector for track profile
 - Wandhalter rechts für Laufschiene
- CR - NO

€ BX.111

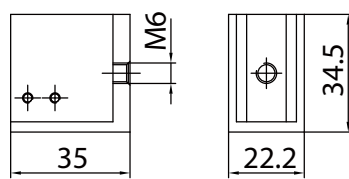

xme556i

BX-6000-C90 SX

- Attacco a parete sinistro per binario
 - Left wall connector for track profile
 - Wandhalter links für Laufschiene
- CR - NO

€ BX.112

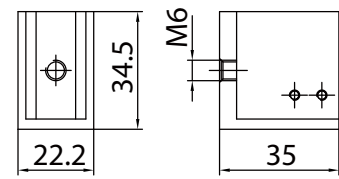

xme556i

BX-6000-C81

- Piastrina attacco a vetro per BX-6000-C90
 - Plate glass connector for BX-6000-C90
 - Platte Glashalter für BX-6000-C90
- CR - NO

€ BX.113

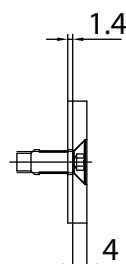

xme556i

BX-PT-C50

€ BX.118

- Guida vetro scorrevole per applicazione con profilo a terra.
 - Floor guide sliding panel for installation with floor profile.
 - Schiebetür Bodenführung für Montage mit Bodenprofile.
- CR - NO

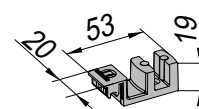

BX-6000 / BX-6020 SOFT-CLOSE

COMPONENTI / COMPONENTS / EINZELTEILE

SCORREVOLI



BX-6000-C20

€ BX.114

- Connettore ad angolo per binari set 1
- Corner connector for track profiles set 1
- Winkelverbinder Laufschiene set 1

CR - NO

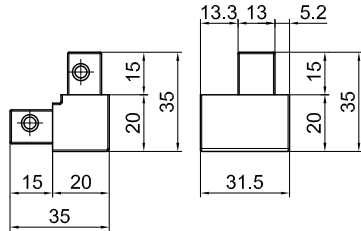

xme556l



BX-6000-DIMA

€ BX.117

- Dima per foratura per morsetto vetro fisso
- Template for drilling the track profile with the clamp
- Schablone für das Bohren der Laufschiene mit der Klemme

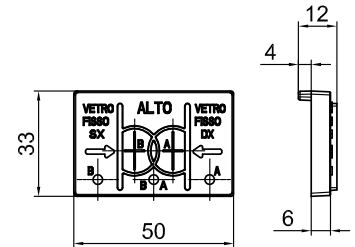

xme556l

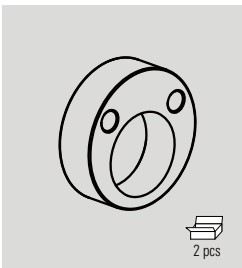

BX-6000 ECCENTR

€ BX.119

- Boccia eccentrica optional per regolazione vetro $\pm 2,5$ mm. Attenzione per foro vetro anta mobile da 23 mm
- Eccentric bushing for glass adjustment $\pm 2,5$ mm. Note well: glass hole 23 mm for sliding panel
- Exzentrisch Buchse für Glas Verstellung $\pm 2,5$ mm. Achtung: Glasbohrung 23 mm für Schiebeflügel

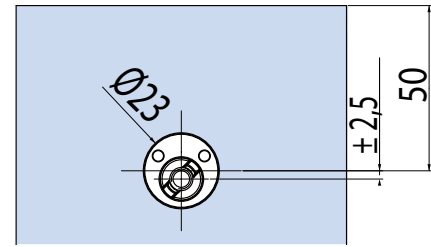
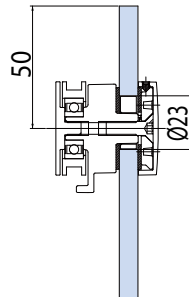
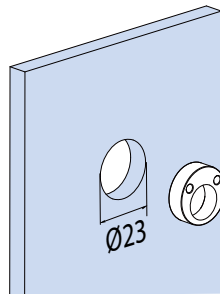

C-330-U



BX-6000-SOFT-CLOSE

€ BX.116

- Soft-close chiusura singola
- Single acting Soft-close
- Soft-close einzeln Wirkende

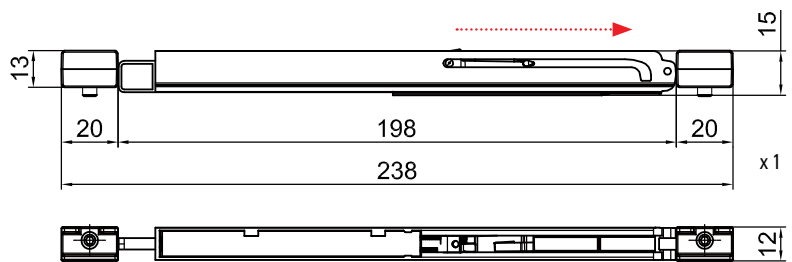

xme556l



BX-PT-C58

€ BX.144

- Profilo per fissaggio a terra o laterale
- Profile for floor and side installation
- Profil Boden- Wandmontage

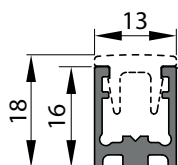

Cod.	Fin./Fin./Fin.
BX-PT-C58-1500 mm	CR / IXE
BX-PT-C58-3000 mm	CR / IXE

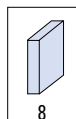

BX-PT-C56

€ BX.145

- Coperchio per profilo a terra per tratto entrata doccia
- Cover profile for floor profile, shower entry.
- Profilabdeckung Bodenprofil Duscheinstieg

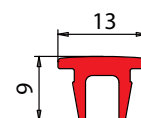

Cod.	Fin./Fin./Fin.
BX-PT-C56-1500 mm	CR / NO
BX-PT-C56-3000 mm	CR / NO



BX-1501

SCORREVOLI



- Sistema scorrevole per box doccia disponibile per versioni in angolo, lineare e in nicchia. Possibilità di regolazione tramite ruota ± 3 mm.
- Sliding system for shower box, available for corners, single doors or for niche installations. Adjustment of carrying wheels ± 3 mm.
- Schiebetürsystem für Duschkabine, lieferbar für Eck-, Linear und Nischenduschen. Höheneinstellung der Räder ± 3 mm.

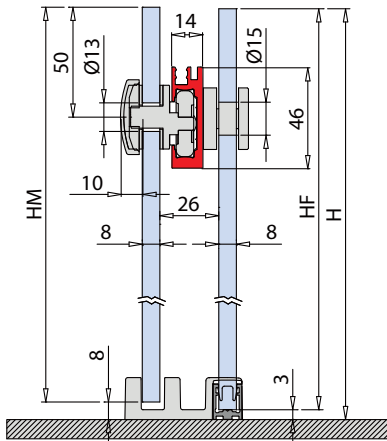

SCORREVOLI



SET 1 €►BX.120

SET 2 €►BX.121

SET 3 €►BX.122

SET 4 €►BX.123

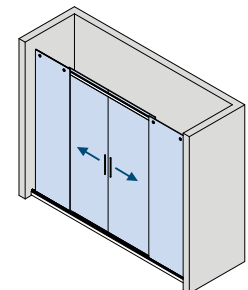
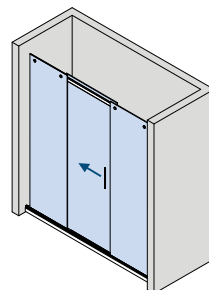
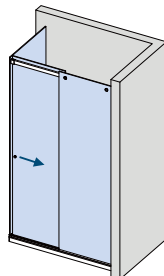
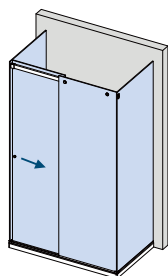
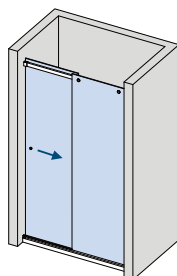
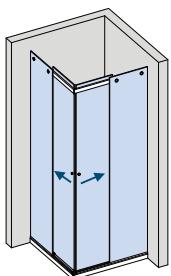
SET 5 €►BX.124

SET 6 €►BX.125

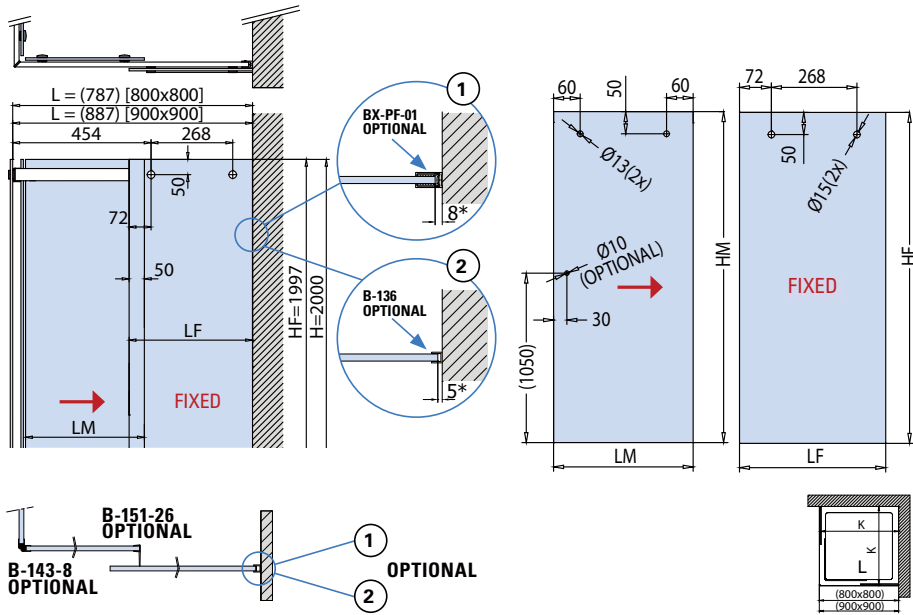
LAVORAZIONE VETRO / GLASS PREPARATION / GLASBEARBEITUNG

CALCOLO VETRO / CALCULATION GLASS / GLASBEREICHNUNG

L = 800 x 800 mm (900 x 900 mm)

LM = (L - 5) / 2

LF = [(L - 5) / 2] - * ① / * ② (aria variabile / clearance / Spaltmaß)

HM = H - 8 = 1992 mm

PROFILI A TERRA / FLOOR PROFILES / BODENPROFILE ▶ 106

A BX-PT-01 STANDARD HF = H - 3 = 1997 mm

B BX-PT-02 OPTIONAL HF = H = 2000 mm

C BX-PT-03 OPTIONAL HF = H = 2000 mm

xfb-050-A

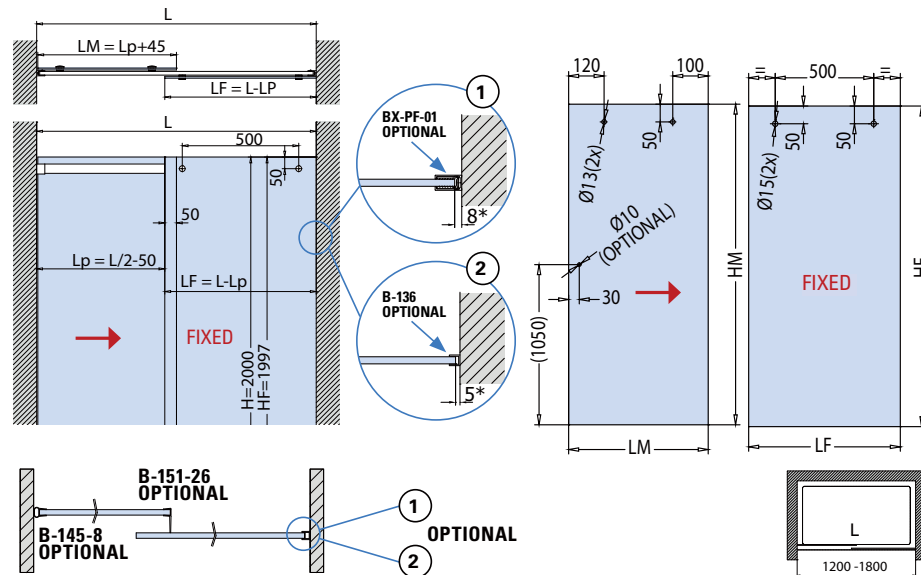
CALCOLO VETRO / CALCULATION GLASS / GLASBEREICHNUNG

L = PIATTO - SHOWER TRAY - DUSCHASSE

LP = L / 2 - 50

LM = LP + 45

LF = L - LP - * ① / * ② (aria variabile / clearance / Spaltmaß)

HM = H - 8 = 1992 mm

PROFILI A TERRA / FLOOR PROFILES / BODENPROFILE ▶ 106

A BX-PT-01 STANDARD HF = H - 3 = 1997 mm

B BX-PT-02 OPTIONAL HF = H = 2000 mm

C BX-PT-03 OPTIONAL HF = H = 2000 mm

xfb-050-B

L Piatto
Shower tray
Duschasse

LM Larghezza vetro mobile
Sliding glass width
Schiebeflügel Breite

LF Larghezza vetro fisso
Side fixed glass width
Seitenteil Breite

HM Altezza vetro mobile
Sliding glass height
Schiebeflügel Höhe

HF Altezza vetro fisso
Side fixed glass height
Seitenteil Höhe

H Altezza doccia
Shower height
Duschkabine Höhe

SET 1 / SET 2
DA TAGLIARE / ADJUST THE LENGTH / BELIEBIG KÜRZBAR ✂

- Forature per fissaggio vetro fisso (fatte dall'installatore).
- Holes in profile for fixed glass.
- Profile not predrilled.
- Bohrungen im Profil für Seitenteil Befestigung. Profil nicht vorgebohrt.

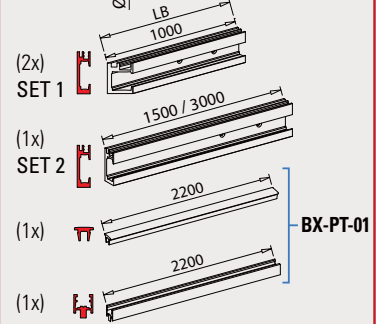
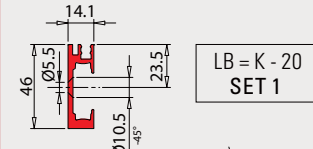

- Regolazione ruota ± 3 mm.
- Adjustment ± 3 mm.
- Verstellung ± 3 mm.

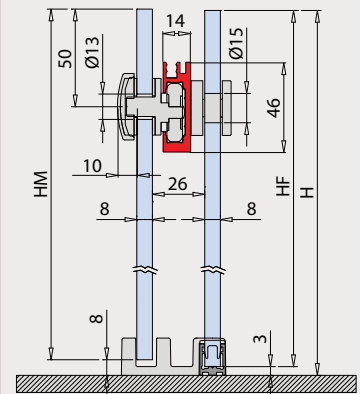

HM = H - 8

HF = H - 3

 solo per / only for / nur für **A** BX-PT-01

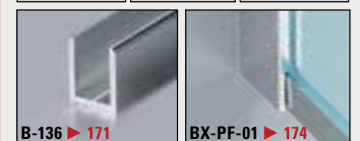
OPTIONAL

SCORREVOLI

BX-1501 SET 3

L = 1500 mm / L = 3000 mm
DOCCIA A U / U SHOWER / U DUSCHE

€ BX.122

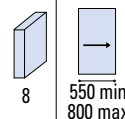

Fin. / Fin. / Oberf.

CR Cromo lucido Polished chrome Chrom glänzend	IXE Effetto inox Inox effect Inox effect
--	--

COMPONENTI / COMPONENTS / EINZELTEILE

- BX-1501-C80 (2x)
- BX-1501-C10 (2x)
- BX-1501-C70 (2x)
- BX-1501-C30 (1x)
- OPTIONAL

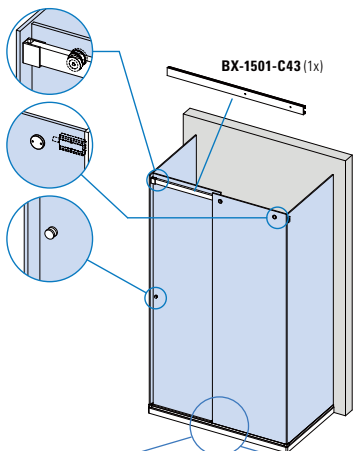

CARATTERISTICHE COMPONENTI /
FEATURES COMPONENTS /
EIGENSCHAFTEN EINZELTEILE ▶ 104

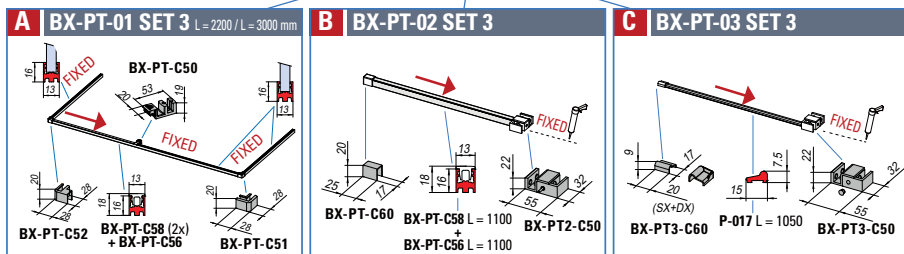

PROFILI A TERRA / FLOOR PROFILES / BODENPROFILE ▶ 106

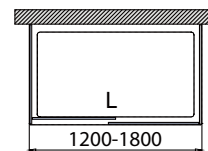

xfb-050-C

BX-1501 SET 4

L = 1500 mm / L = 3000 mm
DOCCIA CON SPALLA IN VETRO / CORNER SHOWER WITH 2 FIXED PANEL /
ECKDUSCHE MIT 2 FESTSTEHENDEN GLASTAFELN

€ BX.123

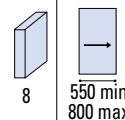

Fin. / Fin. / Oberf.

CR Cromo lucido Polished chrome Chrom glänzend	IXE Effetto inox Inox effect Inox effect
--	--

COMPONENTI / COMPONENTS / EINZELTEILE

- BX-1501-C80 (1x)
- BX-1501-C10 (2x)
- BX-1501-C70 (2x)
- BX-1501-C90 (1x)
- BX-1501-C30 (1x)
- OPTIONAL

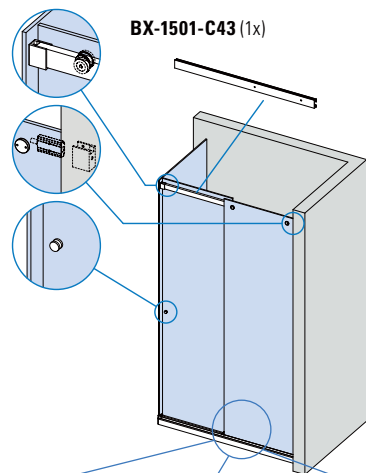

CARATTERISTICHE COMPONENTI /
FEATURES COMPONENTS /
EIGENSCHAFTEN EINZELTEILE ▶ 104

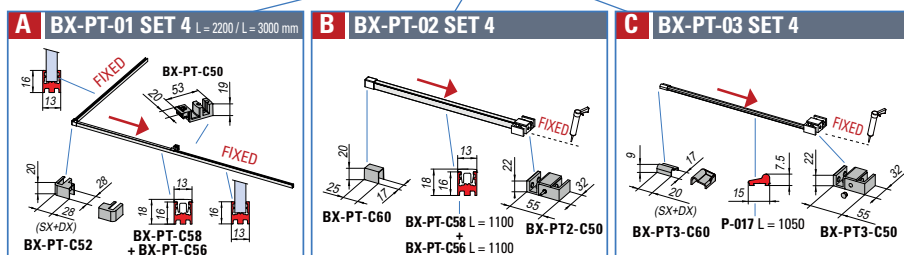

PROFILI A TERRA / FLOOR PROFILES / BODENPROFILE ▶ 106

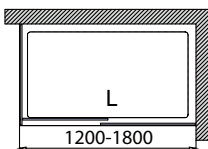

xfb-050-D

SCORREVOLI

LAVORAZIONE VETRO / GLASS PREPARATION / GLASBEARBEITUNG

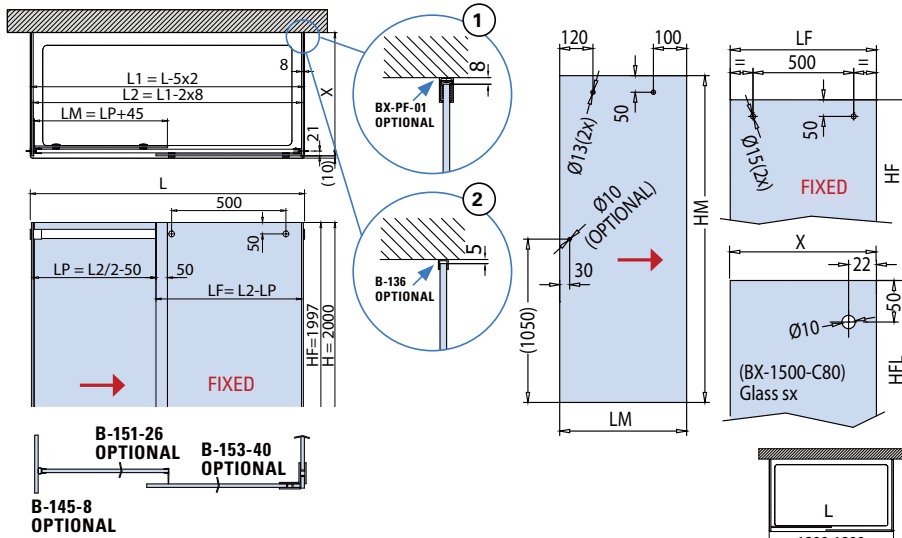

CALCOLO VETRO / CALCULATION GLASS / GLASBERECHNUNG

L = PIATTO - SHOWER TRAY - DUSCHTASSE

$$L1 = L - 5 \times 2$$

$$L2 = L1 - 2 \times 8$$

$$LP = L2 / 2 - 50$$

$$LM = LP + 45$$

$$LF = L2 - LP$$

X = calcolare / calculate / berechnen

X = vedi (1)(2) / see (1)(2) / siehe (1)(2)

PROFILI A TERRA / FLOOR PROFILES / BODENPROFILE ▶ 106

A BX-PT-01 STANDARD HF = H - 3 = 1997 mm HFL = H - 3

B BX-PT-02 OPTIONAL HF = H = 2000 mm HFL = H

C BX-PT-03 OPTIONAL HF = H = 2000 mm HFL = H

xfb-050-C

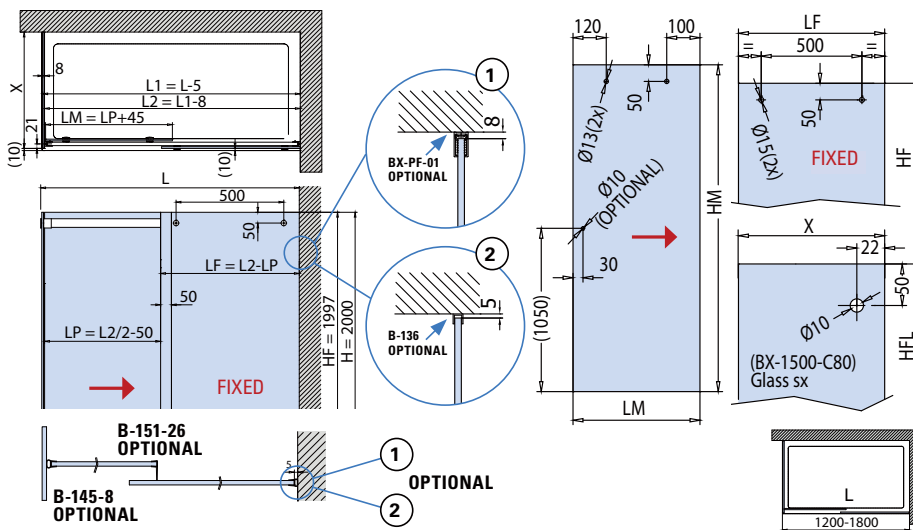

CALCOLO VETRO / CALCULATION GLASS / GLASBERECHNUNG

L = PIATTO - SHOWER TRAY - DUSCHTASSE

$$L1 = L - 5$$

$$L2 = L1 - 8$$

$$LP = L2 / 2 - 50$$

$$LM = LP + 45$$

$$LF = (L2 - LP) \cdot (1) / (2) \text{ (aria variabile / clearance / Spaltmaß)}$$

X = calcolare / calculate / berechnen

X = vedi (1)(2) / see (1)(2) / siehe (1)(2)

PROFILI A TERRA / FLOOR PROFILES / BODENPROFILE ▶ 106

A BX-PT-01 STANDARD HF = H - 3 = 1997 mm HFL = H - 3

B BX-PT-02 OPTIONAL HF = H = 2000 mm HFL = H

C BX-PT-03 OPTIONAL HF = H = 2000 mm HFL = H

xfb-050-D

SET 3 / SET 4

DA TAGLIARE / ADJUST THE LENGTH / BELIEBIG KÜRZBAR ✂

- Forature per fissaggio vetro fisso (fatte dall'installatore).
- Holes in profile for fixed glass.
- Profile not predrilled.
- Bohrungen im Profil für Seitenteil Befestigung. Profil nicht vorgebohrt.

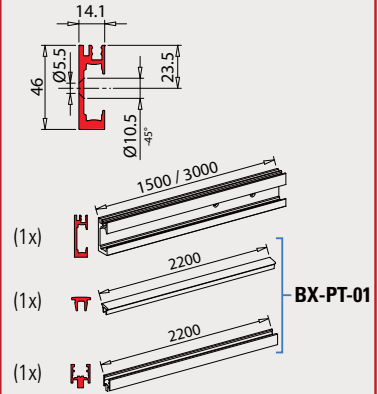

- Regolazione ruota ± 3 mm.
- Adjustment ± 3 mm.
- Verstellung ± 3 mm.

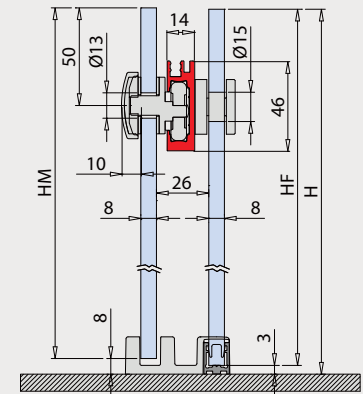

$$HM = H - 8$$

$$HF = H - 3$$

solo per / only for / nur für **A** BX-PT-01

OPTIONAL



L	LP	LM	LF	HM	HF	H	HFL
Piatto Shower tray Duschtaße	Passaggio luce Clear opening width Lichte Durchgangsbreite	Larghezza vetro mobile Sliding glass width Schiebeflügel Breite	Larghezza vetro fisso Side fixed glass width Seitenteil Breite	Altezza vetro mobile Sliding glass height Schiebeflügel Höhe	Altezza vetro fisso Side fixed glass height Seitenteil Höhe	Altezza doccia Shower height Duschkabine Höhe	Altezza vetro fisso laterale Side fixed glass height Seitenteil (seitlich) Höhe

BX-1501

COMPONENTI / COMPONENTS / EINZELTEILE

SCORREVOLI



BX-1501-C43

- Binario
- Track profile
- Laufschiene

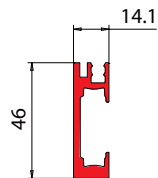

€ BX.127

Cod.	Fin./Fin./Oberf.
BX-1501-C43-1500 mm	CR / IXE
BX-1501-C43-3000 mm	CR / IXE
BX-1501-C01-1000 x 1000 mm (2 pcs 45°)	CR / IXE

xfb-077



BX-1501-C10

- Ruota
- Roller
- Laufrolle

CR - NS

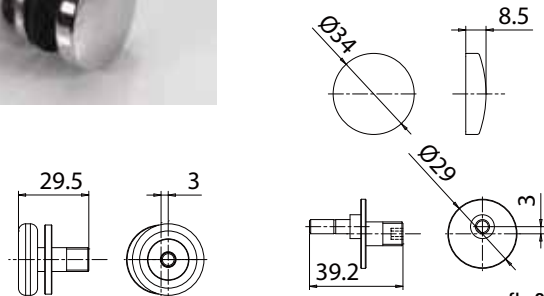

€ BX.128

xfb-077



BX-1501-C70

- Punto di fissaggio vetro fisso al binario
- Fixing point for fixed glass and track profile
- Punkthalter für Fixierung des Festteils auf Laufschiene

CR - NS

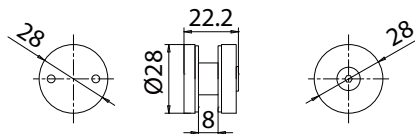

€ BX.129

xfb-077



BX-1501-C90 DX

- Attacco a parete destro per binario
- Right wall connector for track profile
- Wandhalter rechts für Laufschiene

CR - NS

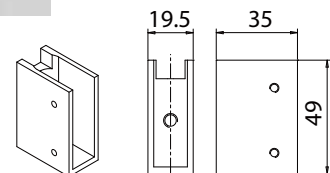

€ BX.130

xfb-077



BX-1501-C90 SX

- Attacco a parete sinistro per binario
- Left wall connector for track profile
- Wandhalter links für Laufschiene

CR - NS

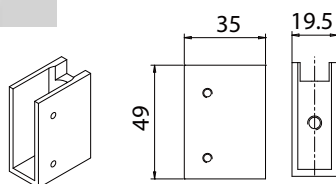

€ BX.131

xfb-077



BX-1501-C81

- Piastrina attacco a vetro
- Plate glass connector for track profile
- Platte Glashalter

CR - NS

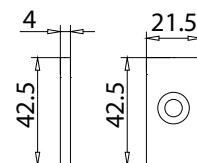

€ BX.132

xfb-077



BX-1501-C30

- Stopper

CR - NS

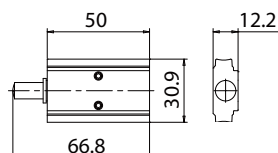

€ BX.133

xfb-077



BX-1501-C20

- Connettore ad angolo per binario
- Corner connector for track profile
- Winkelverbinder Laufschiene

CR - NS

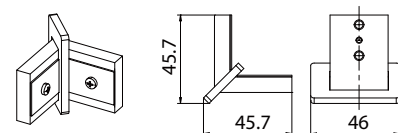

€ BX.134

xfb-077



SCORREVOLI



A

BX-PT-01 STANDARD
COMPONENTI / COMPONENTS / EINZELTEILE

Per modelli: / For models: / Für Modelle:
BX-1501, BX-4000, BX-6000, BX-6020,
BX-5000, BX-6050, BX-DIV5000

- Vetro fisso nel profilo continuo H 16 mm.
- Fixed glass in shower entry floor profile H 16 mm.
- Festverglasung im Duscheinstieg Bodenprofil H 16 mm.

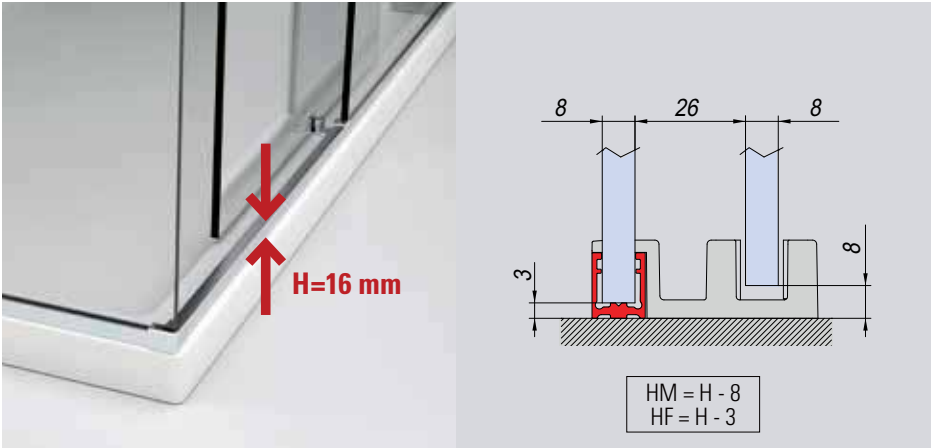

SET ▶ 16

SCORREVOLI



BX-PT-C58

€▶ BX.144

- Profilo per fissaggio a terra o laterale
- Profile for floor and side installation
- Profil Boden- Wandmontage

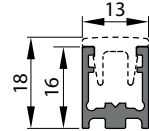

Cod.	Fin./Fin./Oberf.
BX-PT-C58-1500 mm	CR / NO / OR / IXE / BI
BX-PT-C58-3000 mm	CR / NO / OR / IXE / BI

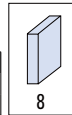

BX-PT-C56

€▶ BX.145

- Coperchio per profilo a terra per tratto entrata doccia.
- Cover profile for floor profile, shower entry.
- Profilabdeckung Bodenprofil, Duscheinstieg.

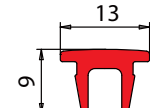

Cod.	Fin./Fin./Oberf.
BX-PT-C56-1500 mm	CR / NO / OR / IXE / BI
BX-PT-C56-3000 mm	CR / NO / OR / IXE / BI



BX-PT-C50

€▶ BX.150

- Guida vetro scorrevole per applicazione con profilo a terra.
- Floor guide sliding panel for installation with floor profile.
- Schiebetür Bodenführung für Montage mit Bodenprofil.

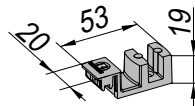

BX-PT-C57

€▶ BX.152

- Angolo 90° lato entrata doccia ad angolo per profili BX-PT-C58 / BX-PT-C56.
- Joint 90° corner entry for profiles BX-PT-C58 / BX-PT-C56.
- 90° Verbindung Eckeinstieg für Profile BX-PT-C58 / BX-PT-C56.

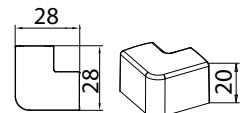

BX-PT-C51

€▶ BX.154

- Angolo 90° vetro fisso/vetro fisso per profilo BX-PT-C58.
- Joint 90° fixed/fixed glass for profile BX-PT-C58.
- 90° Verbindung 2 Festverglasungen für Profil BX-PT-C58.

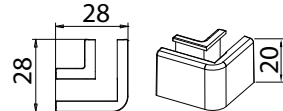

BX-PT-C52

€▶ BX.155

- Angolo 90° per lato entrata doccia e lato vetro fisso dx e sx per profili BX-PT-C58 / BX-PT-C56.
- Joint 90° entry and fixed glass, left and right for profiles BX-PT-C58 / BX-PT-C56.
- 90° Verbindung Einstieg-Festverglasung, Links und Rechts für Profile BX-PT-C58 / BX-PT-C56.

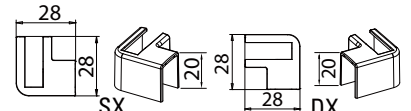

BX-PT-C60

€▶ BX.153

- Coperchietto finale per profili BX-PT-C58 / BX-PT-C56.
- Endcap for profiles BX-PT-C58 / BX-PT-C56.
- Endkappe für Profile BX-PT-C58 / BX-PT-C56.

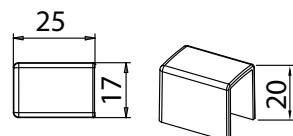

CR
Cromo lucido
Polished chrome
Chrom glänzend

NO
Nero opaco
Matt black
Matt schwarz

NS
Nickel satinato
Satin nickel
Ähnlich edelstahl matt

IXE
Effetto inox satinato
Inox effect
Inox effekt

BI
Bianco opaco
Matt white
Weiss matt

OR
Oro opaco
Matt gold
Gold matt

B BX-PT-02 SOLO PORTA OPTIONAL

COMPONENTI / COMPONENTS / EINZELTEILE

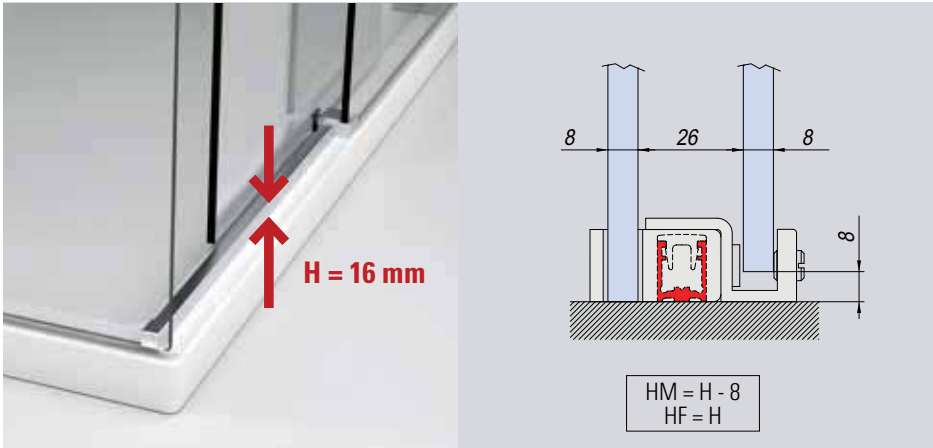

Per modelli: / For models: / Für Modelle:
BX-1501, BX-4000, BX-6000, BX-6020,
BX-5000, BX-6050, BX-DIV5000

- Vetro fisso su piatto doccia, solo profilo entrata H 16 mm.
- Fixed glass on shower tray, only shower entry floor profile H 16 mm.
- Festverglasung auf Duschtasse, Duscheinstieg Bodenprofil H 16 mm.

SET ► 16

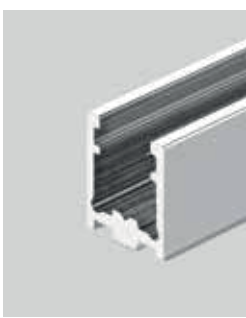

BX-PT-C58 €►BX.144

- Profilo per fissaggio a terra o laterale
- Profile for floor and side installation
- Profil Boden- Wandmontage

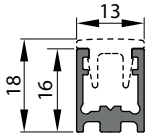

Cod.	Fin./Fin./Oberf.
BX-PT-C58-1500 mm	CR / NO / OR / IXE / BI
BX-PT-C58-3000 mm	CR / NO / OR / IXE / BI

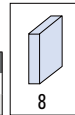

BX-PT-C56 €►BX.145

- Coperchio per profilo a terra per tratto entrata doccia.
- Cover profile for floor profile, shower entry.
- Profilabdeckung Bodenprofil, Duscheinstieg.

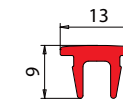

Cod.	Fin./Fin./Oberf.
BX-PT-C56-1500 mm	CR / NO / OR / IXE / BI
BX-PT-C56-3000 mm	CR / NO / OR / IXE / BI



BX-PT2-C50 €►BX.150

- Guida vetro scorrevole per applicazione con profilo a terra.
- Floor guide sliding panel for installation with floor profile.
- Schiebetür Bodenführung für Montage mit Bodenprofile.

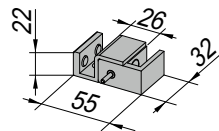

BX-PT-C57 €►BX.152

- Angolo 90° lato entrata doccia ad angolo per profili BX-PT-C58 / BX-PT-C56.
- Joint 90° corner entry for profiles BX-PT-C58 / BX-PT-C56.
- 90° Verbindung Eckeinstieg für Profile BX-PT-C58 / BX-PT-C56.
- CR - NO - NS - BI - OR

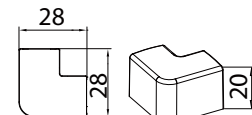

BX-PT-C51 €►BX.154

- Angolo 90° vetro fisso/vetro fisso per profilo BX-PT-C58.
- Joint 90° fixed/fixed glass for profile BX-PT-C58.
- 90° Verbindung 2 Festverglasungen für Profil BX-PT-C58.
- CR - NO - NS - BI - OR

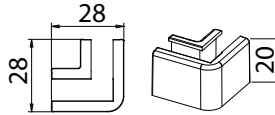

BX-PT-C52 €►BX.155

- Angolo 90° per lato entrata doccia e lato vetro fisso dx e sx per profili BX-PT-C58 / BX-PT-C56.
- Joint 90° entry and fixed glass, left and right for profiles BX-PT-C58 / BX-PT-C56.
- 90° Verbindung Einstieg-Festverglasung, Links und Rechts für Profile BX-PT-C58 / BX-PT-C56.
- CR - NO - NS - BI - OR

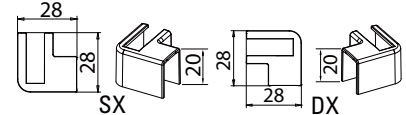

BX-PT-C60 €►BX.153

- Coperchietto finale per profili BX-PT-C58 / BX-PT-C56.
- Endcap for profiles BX-PT-C58 / BX-PT-C56.
- Endkappe für Profile BX-PT-C58 / BX-PT-C56.
- CR - NO - NS - BI - OR

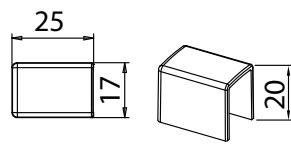

V-012-REG €►BX.161

- Guida a pavimento regolabile per vetro da 8 a 13,5 mm.
- Floor guide adjustable for glass from 8 to 13,5 mm.
- Bodenführung verstellbar für Glas von 8 bis 13,5 mm.
- AN - NS - CR

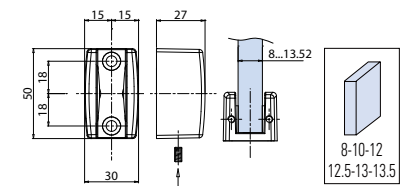
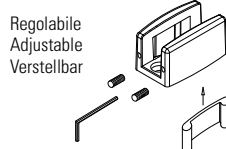

CR
Cromo lucido
Polished chrome
Chrom glänzend

NO
Nero opaco
Matt black
Matt schwarz

AN
Alluminio anodizzato
Aluminium anodized
Aluminium Silberfarbig

NS
Nickel satinato
Satin nickel
Ähnlich Edelstahl matt

IXE
Effetto inox satinato
Matt white
Inox effect
Inox effekt

BI
Bianco opaco
Matt white
Weiss matt

OR
Oro opaco
Matt gold
Gold matt

C

BX-PT-03 RASO DOCCIA OPTIONAL
COMPONENTI / COMPONENTS / EINZELTEILE

Per modelli: / For models: / Für Modelle:
BX-1501, BX-4000, BX-6000, BX-6020,
BX-5000, BX-6050, BX-DIV5000

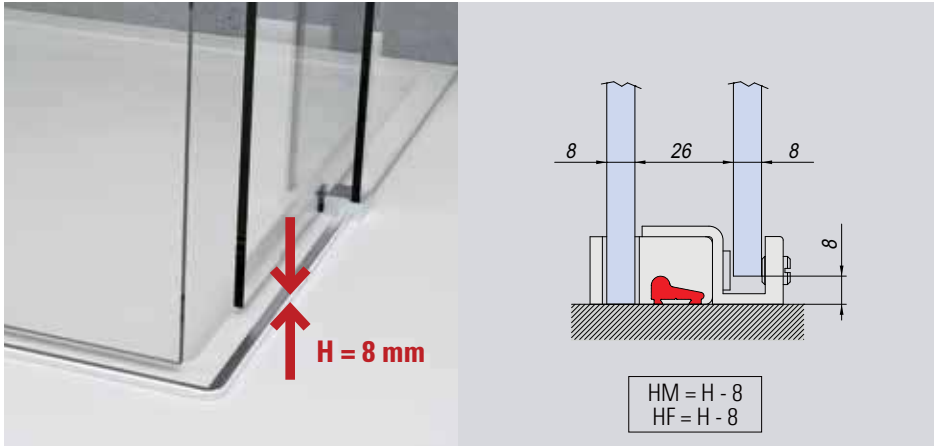

- Vetro fisso su piatto doccia, profilo entrata H 8 mm.
- Fixed glass on shower tray, shower entry profile H 8 mm.
- Festverglasung auf Duschtasse, Duscheinstieg Bodenprofil H 8 mm.

SET ▶ 16

SCORREVOLI



P-017

- Profilo gocciolatoio
- Splash guard profile
- Schwallschutz Profil

CR - NO

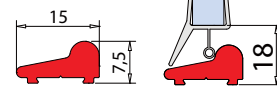

B-147
Option

Cod.	Fin./Fin./Oberf.
P-017-2100 mm	CR / NO

€▶ **BX.255**



BX-PT3-C50

- Guida vetro scorrevole per applicazione con profilo a terra P-017.
- Floor guide sliding panel for installation with floor profile P-017.
- Schiebetür Bodenführung für Montage mit Bodenprofil P-017.

CR

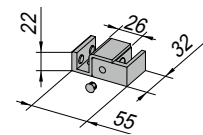

€▶ **BX.157**



BX-PT3-C57

- Angolo 90° lato entrata doccia per profili P-017.
- Joint 90° corner entry for profiles P-017.
- 90° Verbindung Eckeinstieg für Profile P-017.

CR - NO

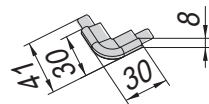

€▶ **BX.159**



BX-PT3-C60

- Coperchietto finale per profili P-017, destro e sinistro.
- Endcap for profiles P-017, left and right.
- Endkappe für Profile P-017 Links und Rechts.

CR - NO

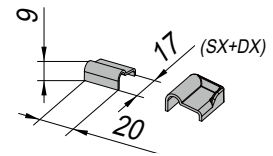

€▶ **BX.160**



V-012-REG

- Guida a pavimento regolabile per vetro da 8 a 13,5 mm.
- Floor guide adjustable for glass from 8 to 13,5 mm.
- Bodenführung verstellbar für Glas von 8 bis 13,5 mm.

AN - NS - CR

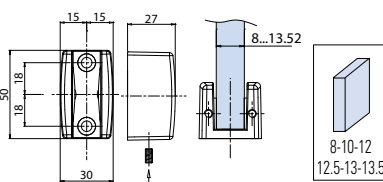

€▶ **BX.161**

Regolabile
Adjustable
Verstellbar

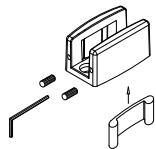

V-012-EVO

- Guida a pavimento regolabile per vetro 8-10-12 mm
- Floor guide adjustable for glass 8-10-12 mm
- Bodenführung verstellbar für Glas 8-10-12 mm

AN - NS - NO - CR

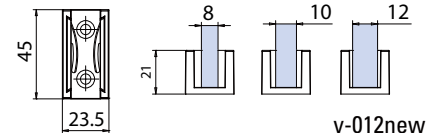

v-012new

CR
Cromo lucido
Polished chrome
Chrom glänzend

NO
Nero opaco
Matt black
Matt schwarz

AN
Alluminio anodizzato
Aluminium anodized
Aluminium Silberfarbig

NS
Nickel satinato
Satin nickel
Ähnlich Edelstahl matt





BOX DOCCIA CON SISTEMA SCORREVOLE A SOFFIETTO

SHOWER BOX WITH SYSTEM FOR CABIN WITH FOLDING DOOR

DUSCHKABIN MIT SYSTEM FÜR FALTÜREN



SOFFIETTI

BX-2700

- Sistema scorrevole per box doccia pieghevole a soffietto. Materiale: alluminio finitura cromo lucido.
- System for showers cabin with folding doors for niche. Material: aluminium Polished Chrome.
- System für Duschkabine mit Faltüren. Material: Aluminium chrom poliert.

► 112

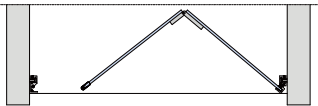

BX-2600

- Sistema scorrevole per box doccia pieghevole a soffietto disponibile nella versione in nicchia. Materiale: alluminio finitura cromo lucido.
- System for shower cabin with folding doors for niche. Material: aluminium Polished Chrome.
- System für Duschkabin mit Faltüren für Nische. Material: Aluminium Chrom poliert.

► 118

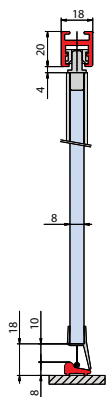
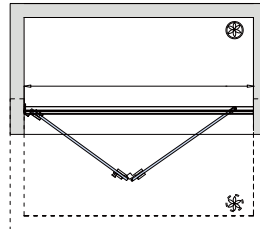

SET 2 €► BX.162

SET 4 €► BX.163

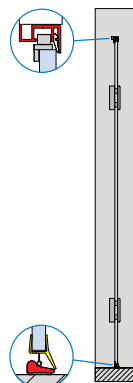
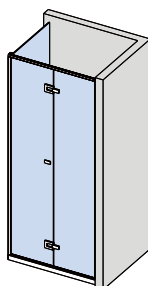
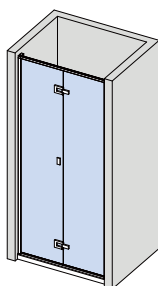

SET 2 €► BX.183

SET 4 €► BX.184

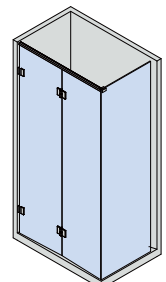
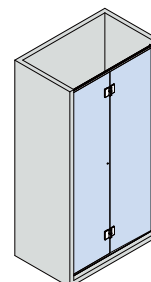

BX-2700



SOFFIETTI

Profili vetro fisso
Profiles for fixed panels
Profil für Festverglasung... ▶ 170

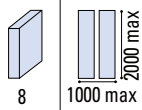
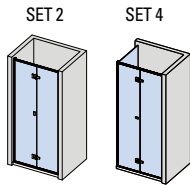
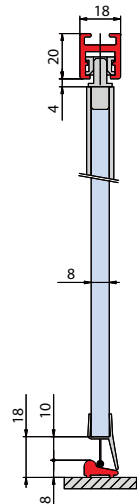

Fin. / Fin. / Oberf.
CR
Cromo lucido
Polished chrome
Chrom glänzend

COMPONENTI / COMPONENTS / EINZELTEILE

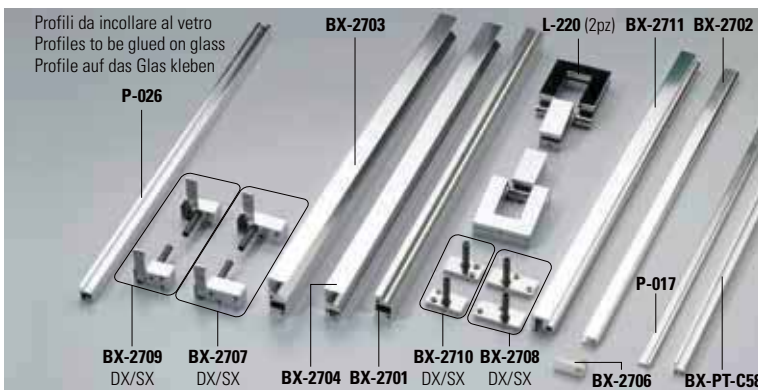

BX-2700 SET 2

€ BX.162

DOCCIA IN NICCHIA / NICHE SHOWER / NISCHENDUSCHE

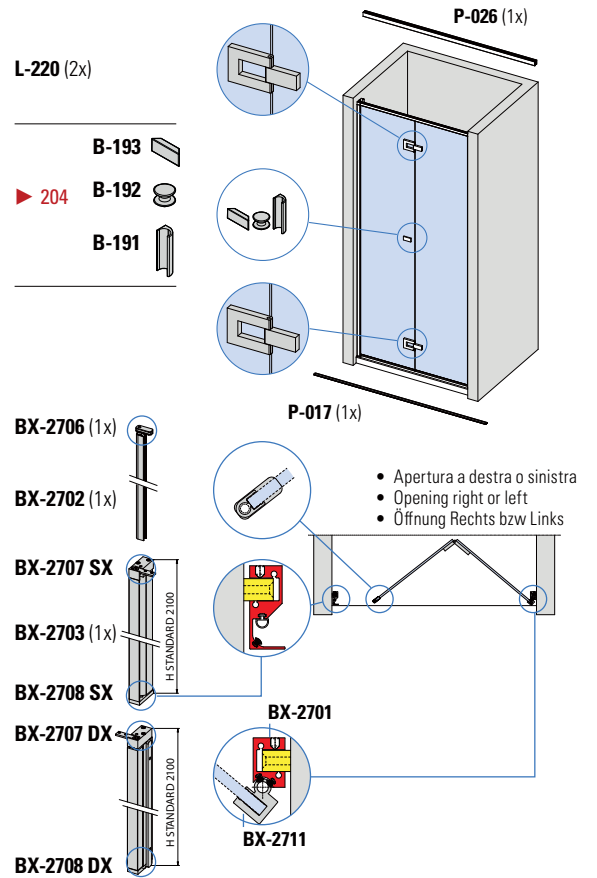

BX-2700 SET 4

€ BX.163

DOCCIA CON SPALLA IN VETRO / CORNER SHOWER WITH 2 FIXED PANEL / ECKDUSCHE MIT 2 FESTSTEHENDEN GLASTAFELN

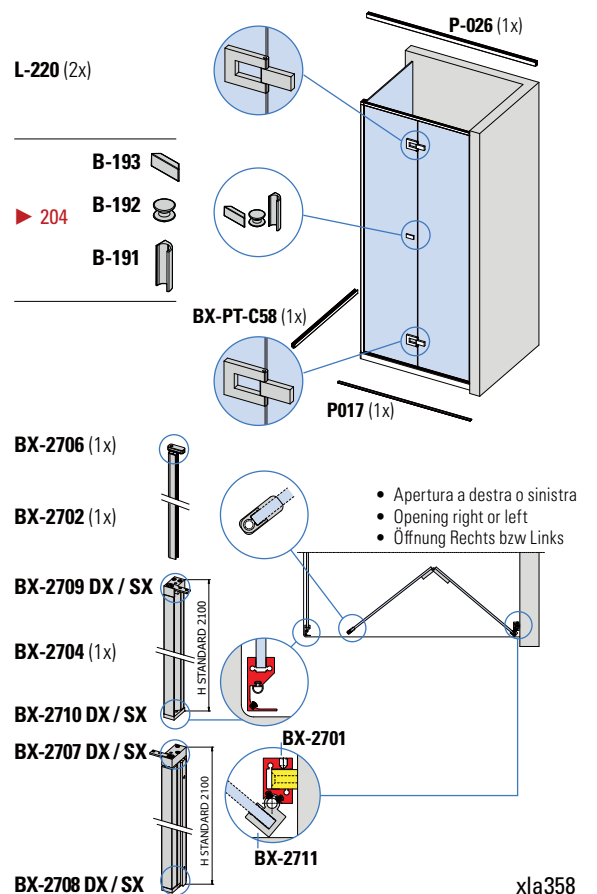

$L = P1 (1000) \text{ mm MAX}$
 $LM1 = LM2 = L1 - 36 / 2$
 $LA1 = LM + 10$
 $LA2 = LM2 + 4$
 $HM1 = HM2 = 2058$

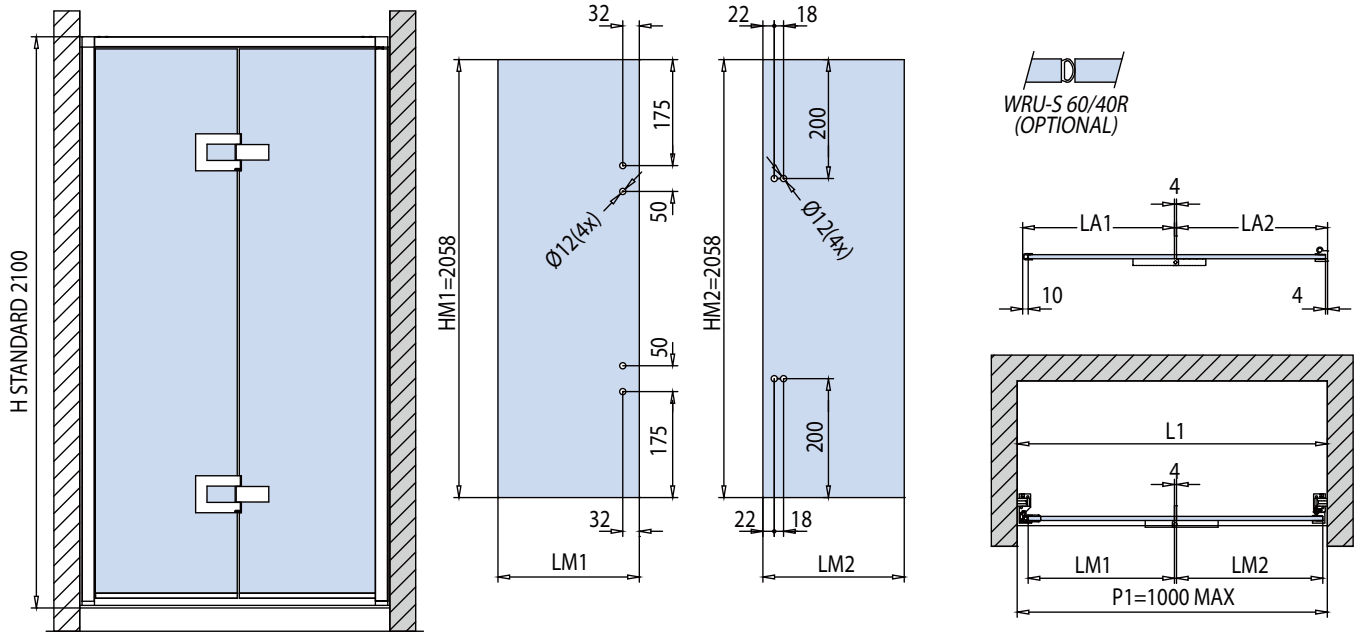

SOFFIETTI

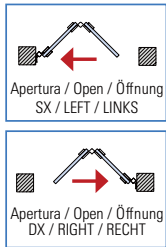

- Indicare sempre il senso di apertura.
- Please specify always opening direction.
- Bitte immer Öffnungsrichtung angeben.

$P1 = P2 (1000) \text{ mm MAX}$
 $L = P1 - 12$
 $LM1 = LM2 = L1 - 24 / 2$
 $L3 = P2 - 5$
 $LF = (L3 - 35) - \textcircled{A}$ aria variabile / clearance / Spaltmaß ▶ 168
 $LA1 = LM1 + 10$
 $LA2 = LM2 + 4$
 $HM1 = HM2 = 2058$
 $HF = 2070$

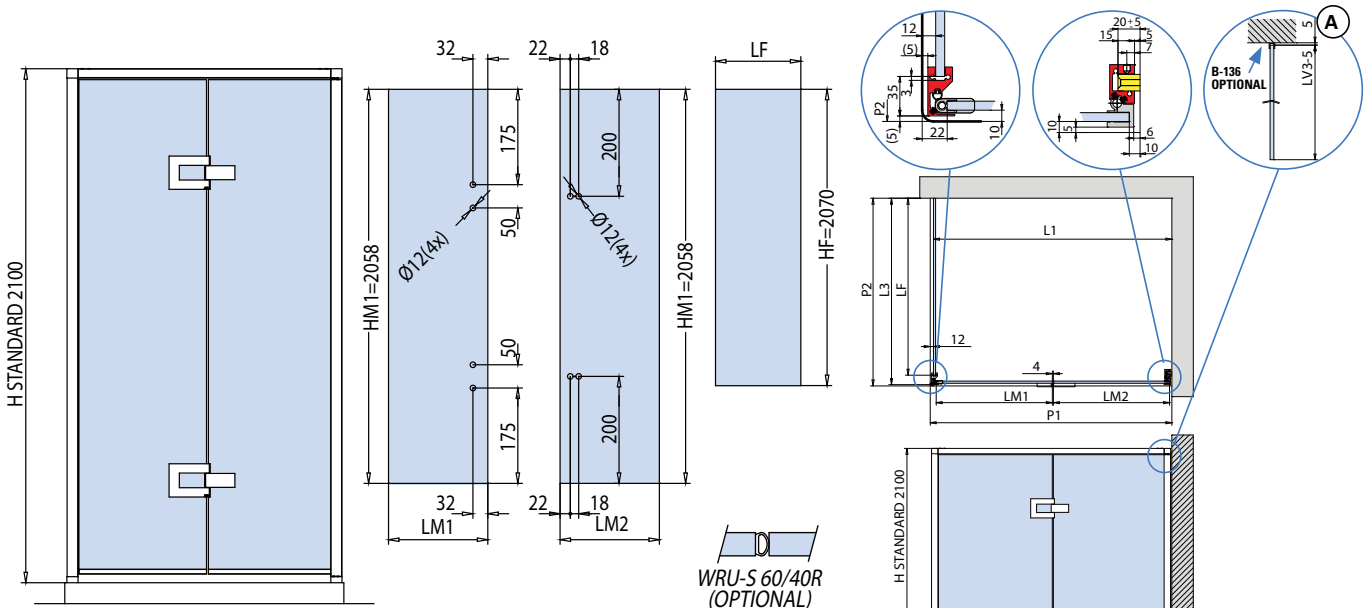

xla358F

L	LA	LM	HM	HF	LF	H
Piatto Shower tray Duschtaße	Larghezza anta Door width Tür-Breite	Larghezza vetro mobile Sliding glass width Glasbreite	Altezza vetro mobile Glass height Glashöhe	Altezza vetro fisso Side fixed glass height Seitenteil Höhe	Larghezza vetro fisso Side fixed glass width Seitenteil Breite	Altezza doccia Shower height Duschkabine Höhe

BX-2700

COMPONENTI / COMPONENTS / EINZELTEILE



P-026

- Binario
- Track profile
- Laufschiene

€▶ BX.164

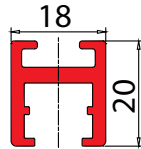

Cod.	Fin./Fin./Oberf.
P-026-1000 mm	CR

xfb-062



BX-2703

- Profilo battuta a muro compreso di guarnizione
- Door stop profile with gasket
- Türanschlagsprofil mit Dichtung

€▶ BX.167

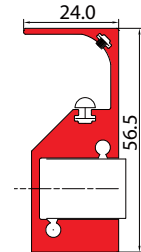

Cod.	Fin./Fin./Oberf.
BX-2703-2200 mm	CR

xfb-062



BX-2701

- Profilo a muro per fissaggio profilo cerniera BX-2711
- Wall profile for installation hinge profile BX-2711
- Wandprofil für Befestigung des Bandprofil BX-2711

€▶ BX.165

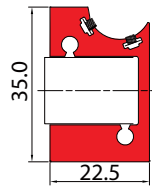

Cod.	Fin./Fin./Oberf.
BX-2701-2200 mm	CR

xfb-062



BX-2704

- Profilo battuta a vetro compreso di guarnizione
- Door stop profile glass installation with gasket
- Türanschlagsprofil Glasmontage mit Dichtung

€▶ BX.168

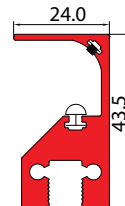

Cod.	Fin./Fin./Oberf.
BX-2704-2200 mm	CR

xfb-062



BX-2702

- Profilo bordo vetro
- Border profile
- Rahmenprofil

€▶ BX.166



Cod.	Fin./Fin./Oberf.
BX-2702-2200 mm	CR

xfb-062

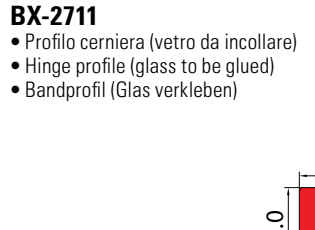

BX-2711

- Profilo cerniera (vetro da incollare)
- Hinge profile (glass to be glued)
- Bandprofil (Glas verkleben)

€▶ BX.169

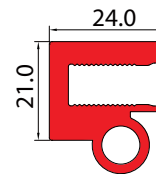

Cod.	Fin./Fin./Oberf.
BX-2711-2200 mm	CR

xfb-062



P-017

- Profilo gocciolatoio
- Splash guard profile
- Schwallschutz Profil

€▶ BX.170

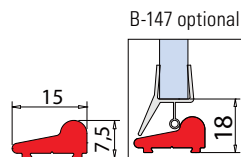

Cod.	Fin./Fin./Oberf.
P-017-2100 mm	CR

xme 203



BX-PT-C58

- Profilo per fissaggio a terra o laterale
- Profile for floor and side installation
- Profil Boden- Wandmontage

€▶ BX.144

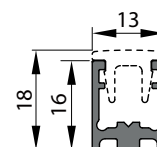

Cod.	Fin./Fin./Oberf.
BX-PT-C58-2200 mm	CR

xla367b

SOPFIETTI

BX-2706

- Perno guida superiore
- Top guiding pin
- Oberer Führungsstift

€▶BX.172

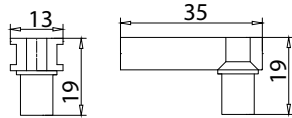

xfb-062

BX-2707-DX

- Attacco destro a parete per binario
- Right wall connector for track profile
- Wandhalter rechts für Laufschiene

€▶BX.175

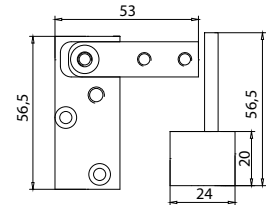

xfb-062

BX-2707-SX

- Attacco sinistro a parete per binario
- Left wall connector for track profile
- Wandhalter links für Laufschiene

€▶BX.176

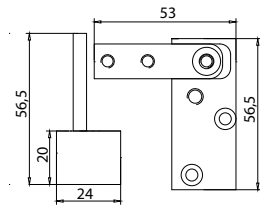

xfb-062

BX-2709-DX

- Attacco destro a vetro per binario
- Right glass connector for track profile
- Glashalter rechts für Laufschiene

€▶BX.179

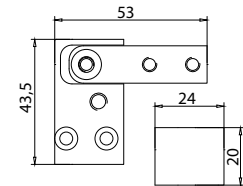

xfb-062

BX-2709-SX

- Attacco sinistro a vetro per binario
- Left glass connector for track profile
- Glashalter links für Laufschiene

€▶BX.180

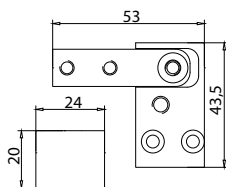

xfb-062

BX-2708-DX

- Piastra inferiore laterale destra
- Bottom right-side plate
- Unterer Platte rechts

€▶BX.177

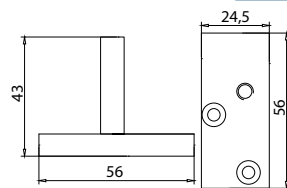

xfb-062

BX-2708-SX

- Piastra inferiore laterale sinistra
- Bottom left-side plate
- Unterer Platte links

€▶BX.178

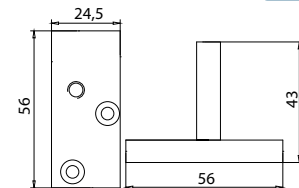

xfb-062

BX-2710-SX

- Piastra inferiore laterale sinistra per BX-2704
- Bottom left-side plate for BX-2704
- Unterer Platte links für BX-2704

€▶BX.182

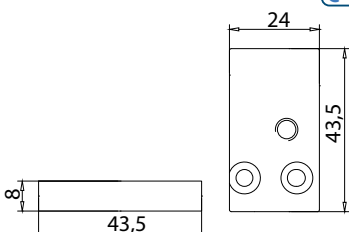

xfb-062

BX-2710-DX

- Piastra inferiore laterale destra per BX-2704
- Bottom right-side plate for BX-2704
- Unterer Platte rechts für BX-2704

€▶BX.181

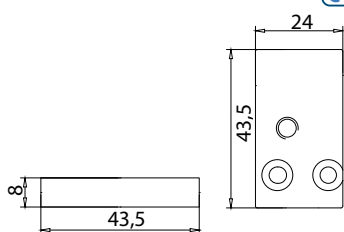

xfb-062

L-220

- Cerniera a scatto vetro/vetro, senza viti in vista. Materiale: Zamak.
- Glass to glass clicking hinge, with not visible screws. Material: Zamak.
- Duschtürband Glas-Glas ohne sichtbaren Schrauben. Material: Zamak. CR

€▶BX.174

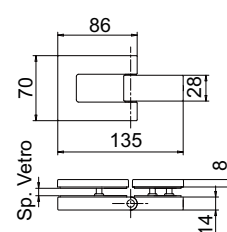

I-220

SOFFIETTI

BX-2700

► 112



SOFFIETTI

BX-2600

► 118



BX-2600



SOFFIETTI

BX-2600 SET 2

€ BX.183

DOCCIA IN NICCHIA / NICHE SHOWER / NISCHENDUSCHE

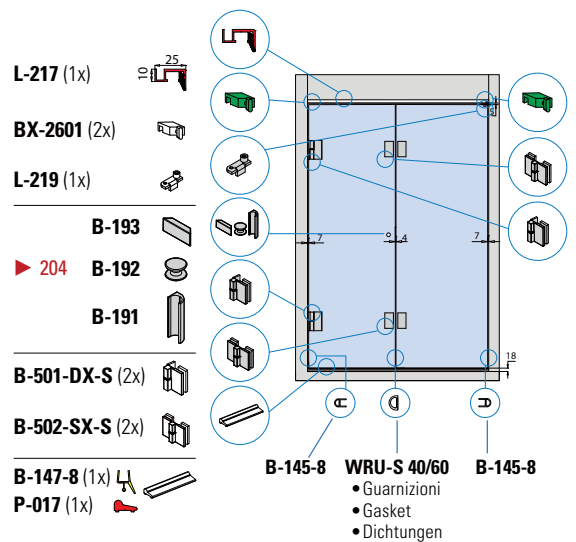

xme300

Profili vetro fisso
Profiles for fixed panels
Profil für Festverglasung... ▶ 170

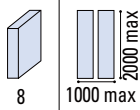

Fin. / Fin. / Oberf.

CR
Cromo lucido
Polished chrome
Chrom glänzend

- Indicare sempre il senso di apertura.
- Please specify always opening direction.
- Bitte immer Öffnungsrichtung angeben.

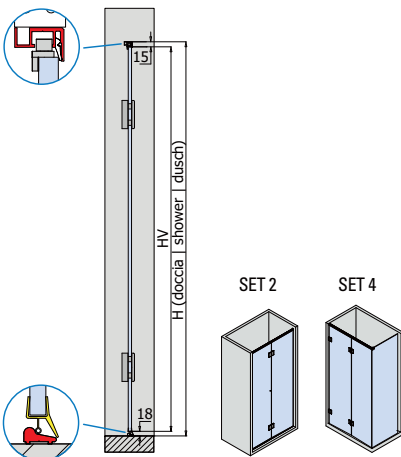
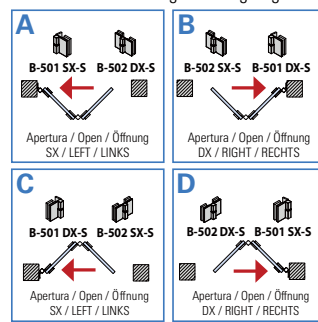

COMPONENTI / COMPONENTS / EINZELTEILE

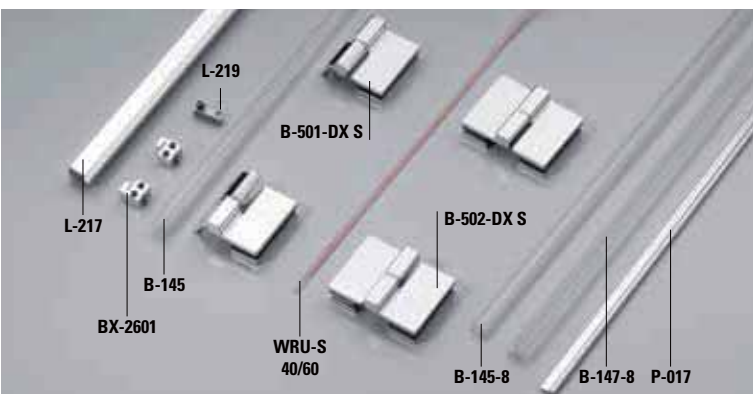

BX-2600 SET 4

€ BX.184

DOCCIA CON SPALLA IN VETRO / CORNER SHOWER WITH 2 FIXED PANEL / ECKDUSCHE MIT 2 FESTSTEHENDEN GLASTAFELN

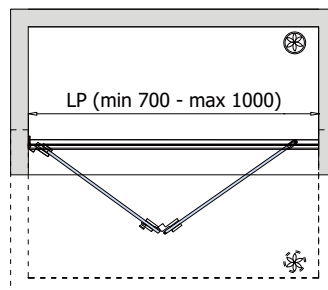
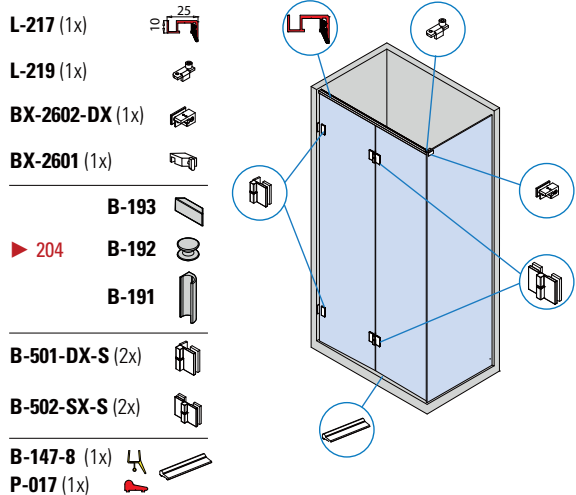

xme359

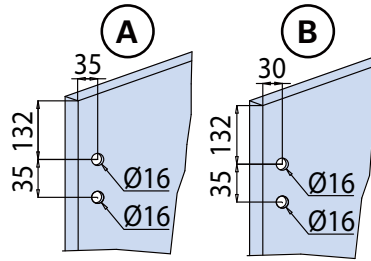
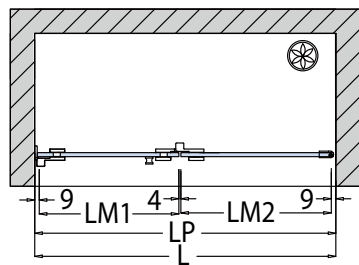
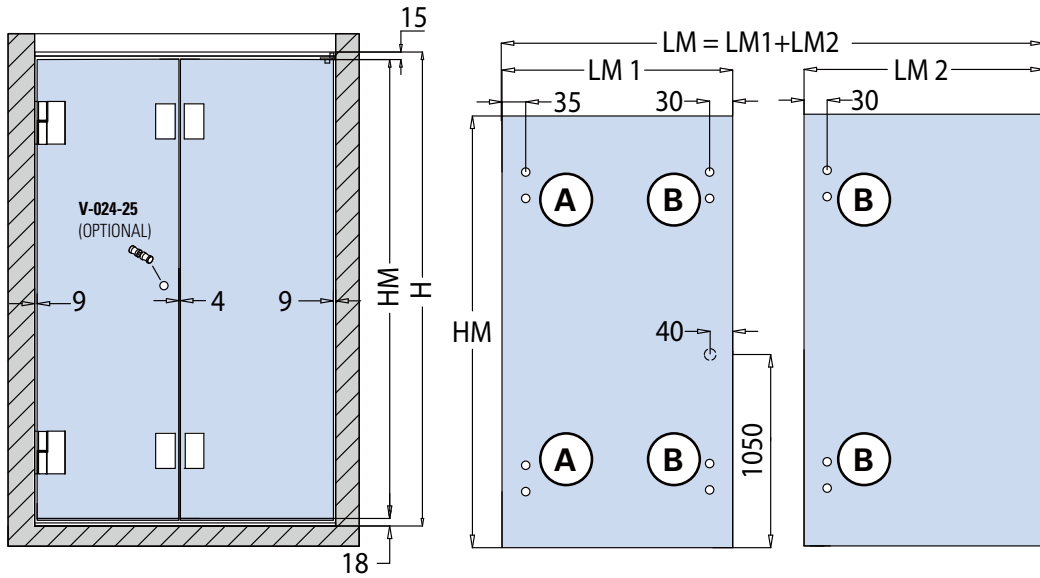

$$\begin{aligned} LM_{tot} &= LP - 22 \\ LM1 &= (LM_{tot} / 2) - 9 \\ LM2 &= (LM_{tot} / 2) + 9 \\ HM &= H - 33 \end{aligned}$$

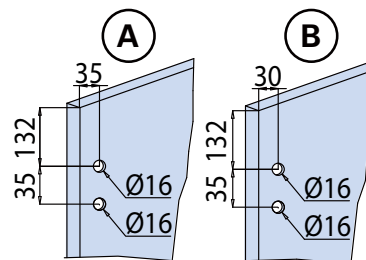
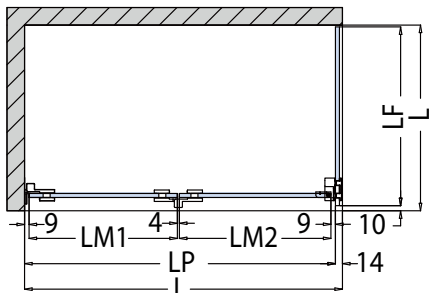
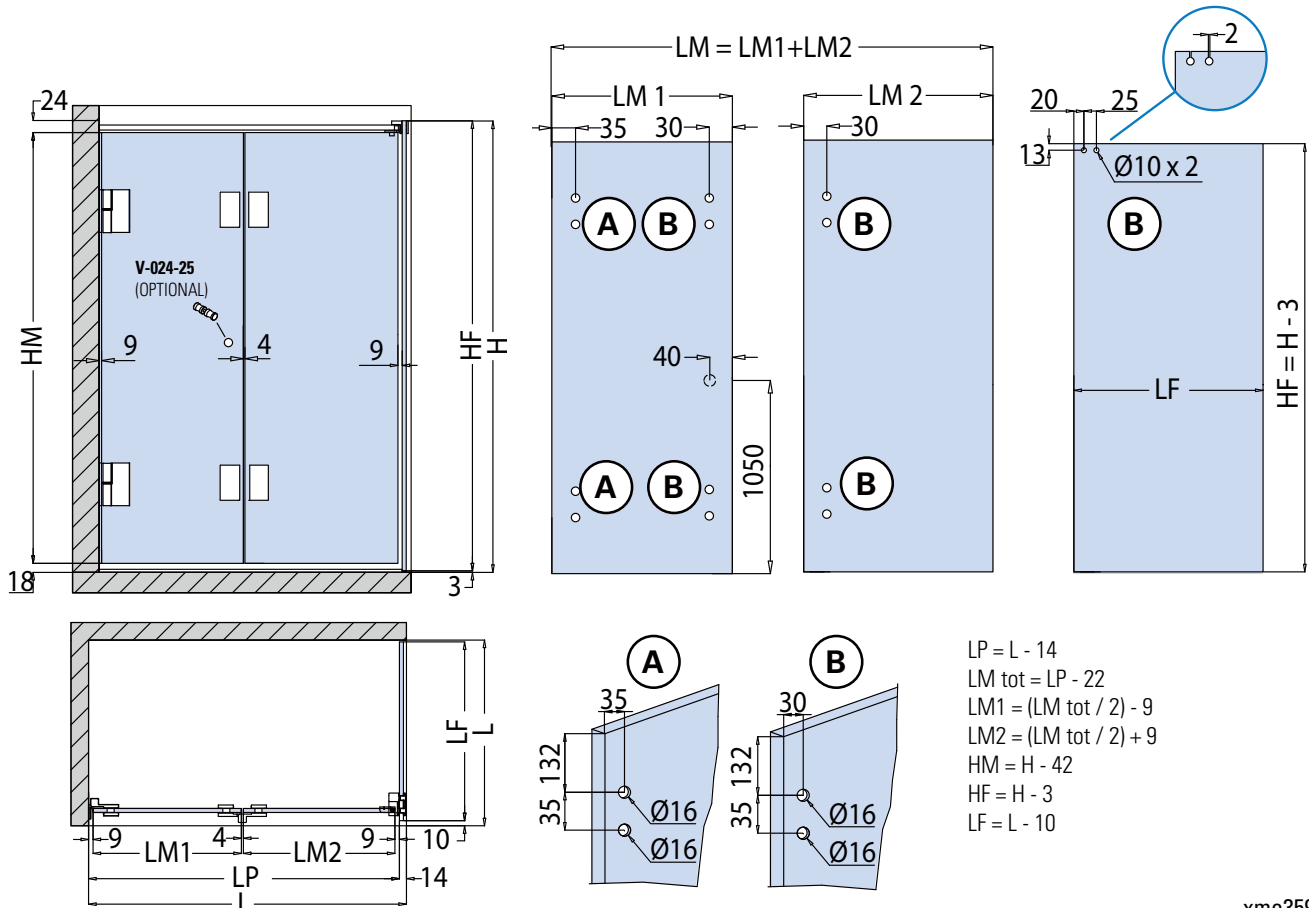

$$\begin{aligned} LP &= L - 14 \\ LM_{tot} &= LP - 22 \\ LM1 &= (LM_{tot} / 2) - 9 \\ LM2 &= (LM_{tot} / 2) + 9 \\ HM &= H - 42 \\ HF &= H - 3 \\ LF &= L - 10 \end{aligned}$$

xme359A

L
Piatto
Shower tray
Duschtaße

LF
Larghezza vetro fisso
Side fixed glass width
Seitenteil Breite

LM
Larghezza vetro mobile
Sliding glass width
Schiebefügel Breite

HM
Altezza vetro mobile
Sliding glass height
Schiebefügel Höhe

H
Altezza doccia
Shower height
Duschkabine Höhe

HF
Altezza vetro fisso
Side fixed glass height
Seitenteil Höhe

BX-2600

COMPONENTI / COMPONENTS / EINZELTEILE



B-502 DX-S

- Cerniera destra vetro/vetro
- Materiale: Zamak.
- Right hinge glass to glass.
- Material: Zamak.
- Band rechts Glas-Glas.
- Material: Zamak.

CR

€ BX.186

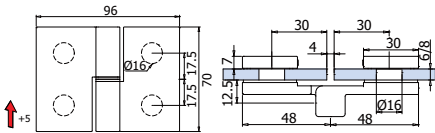

xmc016



B-502 SX-S

- Cerniera sinistra vetro/vetro
- Materiale: Zamak.
- Left glass to glass.
- Material: Zamak.
- Band links Glas-Glas.
- Material: Zamak.

CR

€ BX.187

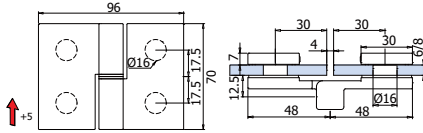

xmc016



B-501 DX-S

- Cerniera destra vetro/muro
- Materiale: Zamak.
- Right hinge wall to glass
- Material: Zamak.
- Band rechts Wand-Glas
- Material: Zamak.

CR

€ BX.188

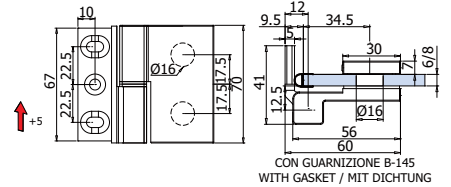

xmc016



B-501 SX-S

- Cerniera sinistra vetro/muro
- Materiale: Zamak.
- Left Hinge wall to glass
- Material: Zamak.
- Band rechts Wand-Glas
- Material: Zamak.

CR

€ BX.189

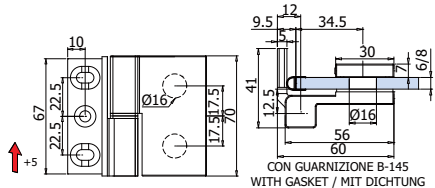

xmc016



L-217

- Binario
- Track profile
- Laufschiene

€ BX.190

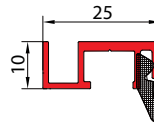

xfb-080

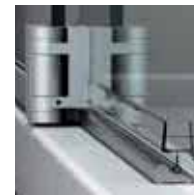

P-017

- Profilo gocciolatoio
- Splash guard profile
- Schwallschutz Profil

€ BX.191

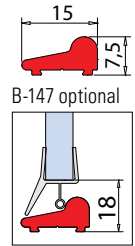

Cod.	Fin./Fin./Oberf.
P-017-2100 mm	CR

xme 203



L-219

- Perno guida superiore (da incollare al vetro)
- Top guiding pin (to be glued on glass)
- Führungsstift (Auf das Glas Kleben)

€ BX.192

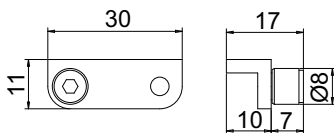

I-2600



BX-2601

- Attacco a parete
- Wall connector
- Wandhalter

CR

€ BX.193

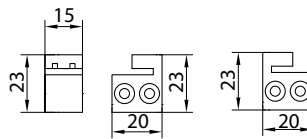

xfb-080



BX-2602 DX

- Attacco destro a vetro
- Right glass connector
- Glashalter rechts

CR

€ BX.194

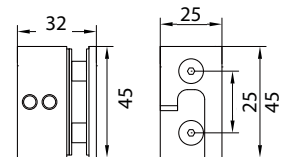

xfb-080



BX-2602 SX

- Attacco sinistro a vetro
- Left glass connector
- Glashalter links

CR

€ BX.195

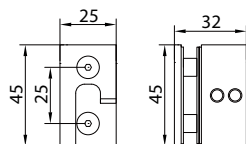

xfb-080



BX-2603 DX

- Attacco destro a vetro e attacco a parete
- Right glass connector and wall connector
- Glashalter rechts und Wandhalter

CR

€ BX.196

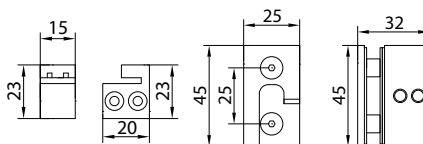

xfb-080



BX-2603 SX

- Attacco sinistro a vetro e attacco a parete
- Left glass connector and wall connector
- Glashalter links und Wandhalter

CR

€ BX.197

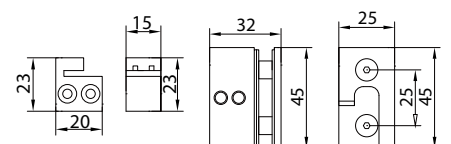

xfb-080

B-147-8

- Guarnizione gocciolatoio in PVC trasparente. Lunghezza barre 2200 mm. Per vetro da 8 mm
- Drip flap seal transparent PVC Bar length is 2200 mm. For 8 mm glass.
- Pvc Dichtprofil für den unteren Wannenanschluss für 8 mm oder Glas. Länge 2200 mm.

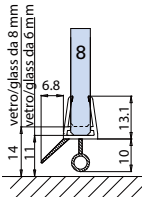

xme318

B-145-8

- Guarnizione a palloncino vetro/muro in PVC trasparente. L = 2200 mm
- Glass to wall ball seal transparent PVC. L = 2200 mm
- PVC Dichtprofil Glas-Wand. L = 2200 mm

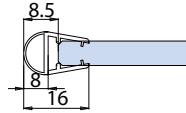

xme390

WRU-C-BUMP-MT12

- Guarnizione neutra per vetro 8 mm, fissaggio adesivo
- Neutral gasket for glass 8 mm with adhesive fixing
- Dichtungsprofil für 8 mm. selbstklebend

12 m

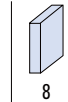
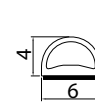
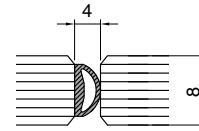

BOX DOCCIA CON ANTA A BATTENTE

SHOWER BOX WITH SWING DOOR / DUSCHKABINE MIT DREH-TÜR

- BOX DOCCIA CON ANTA A BATTENTE (CERNIERA A SCATTO)
- SHOWER BOX WITH SWING DOOR (DOUBLE ACTION CLICKING HINGES)
- DUSCHKABINE MIT DREH-TÜR (SELBSTSCHLIESSENDE PENDEL TURBÄNDER)



B-751 ▶ 125 **B-752 ▶ 125** **B-753 ▶ 127**



B-754 ▶ 127 **B-701 ▶ 129** **B-702 ▶ 129**



B-301 ▶ 131 **B-306 ▶ 131** **L-220 ▶ 131**



B-100 ▶ 132 **B-101 ▶ 132** **B-102 ▶ 132**



B-103 ▶ 133 **B-150 ▶ 133** **B-400 ▶ 134**



B-401 ▶ 134 **B-402 ▶ 134** **B-405 ▶ 135**

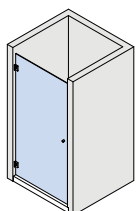

- CERNIERE A SCATTO IN BATTUTA (GUARNIZIONE CONTINUA)
- CLICKING HINGES FOR CONTINUOUS SEALS
- ANSCHLAGTÜRBÄNDER (DURCHGEHENDER DICHTUNG)



B-201 ▶ 137 **B-202 ▶ 137**

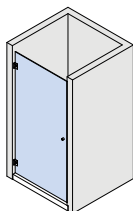

- CERNIERE CON ALZATA IN APERTURA
- HINGES WITH LIFT-LOWER FUNCTION
- BÄNDER MIT HEBE-SENK FUNKTION



BX-551 / B-553 DX-SX ▶ 139 **BX-552 / B-554 DX-SX ▶ 141**



BX-501 DX-SX ▶ 143 **BX-502 DX-SX ▶ 143**

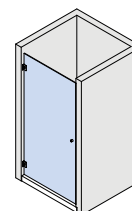

- CERNIERE IN BATTUTA (GUARNIZIONE CONTINUA)
- HINGES FOR CONTINUOUS SEALS
- ANSCHLAGTÜRBÄNDER (DURCHGEHENDER DICHTUNG)



B-711 ▶ 145 **B-712 ▶ 145**



B-621 ▶ 147 **B-622 ▶ 147**



B-105 ▶ 148 **B-104 ▶ 148**

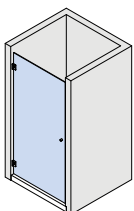

- PIVOT ALTO-BASSO (BILICO) - PORTA BATTENTE
- TOP/BOTTOM PIVOT HINGES
- OBERE/UNTERE PIVOT BÄNDER



BX-2100 BILICO ▶ 150



B-305 ▶ 156

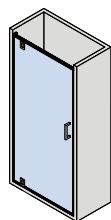

B-303 BILICA ▶ 158

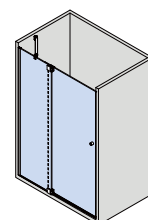

NEW

CERNIERE A SCATTO

CLICKING HINGES / SELBSTSCHLIESSENDE BÄNDER



CERNIERE



MORSETTI COORDINATI ▶ 190
COORDINATED CLAMPS
KOORDINIERTE KLEMMEN

B-751

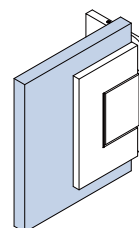
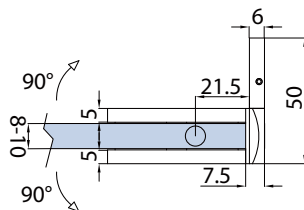
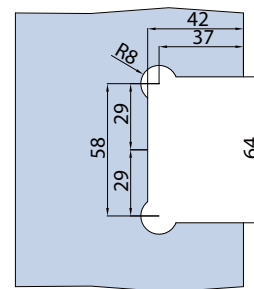
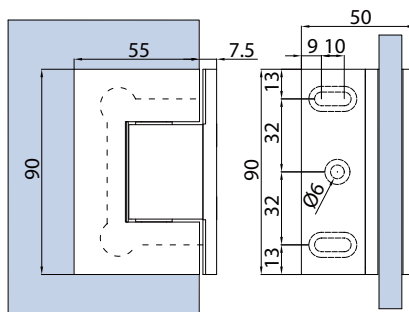
- Cerniera a scatto vetro muro regolabile posizione "0", senza viti a vista. Materiale: Zamak.
 - Glass to wall double action clicking hinge, no visible screws. "0" position adjustable. Material: Zamak.
 - Pendeltürband Glas-Wand ohne sichtbare Schrauben, mit verstellbarer Nulllagenstellung. Material: Zamak.
- CR - NS - NO

 LAVORAZIONE VETRO
 GLASS PREPARATION
 GLASBEARBEITUNG

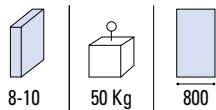
xme624a



8-10

50 Kg

800



CERNIERE

B-752

- Cerniera a scatto regolabile vetro/vetro senza viti a vista. Materiale: Zamak.
 - Adjustable glass/glass clicking hinge, no visible screws. Material: Zamak.
 - Pendeltürband Glas-Glas ohne sichtbare Schrauben, mit verstellbarer Nulllagenstellung. Material: Zamak.
- CR - NS - NO

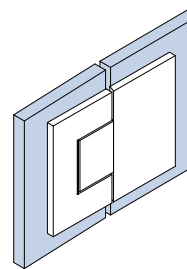
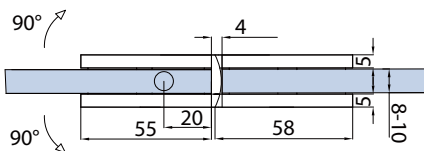
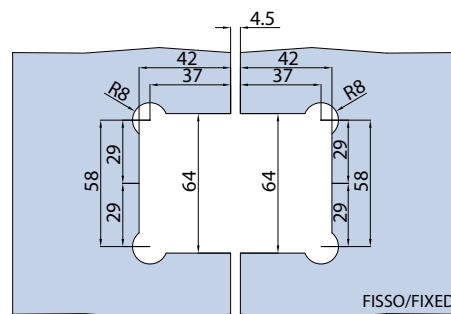
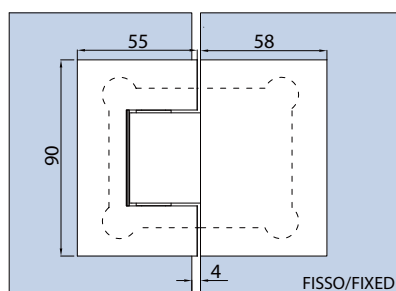
 LAVORAZIONE VETRO
 GLASS PREPARATION
 GLASBEARBEITUNG

xme624c

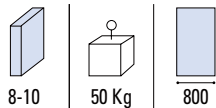

8-10

50 Kg

800

CR
 Cromo lucido
 Polished chrome
 Chrom glänzend

NS
 Nickel satinato
 Satin nickel
 Ähnlich Edelstahl matt

NO
 Nero opaco
 Matt black
 Matt schwarz

NEW

CERNIERE A SCATTO

CLICKING HINGES / SELBSTSCHLIESSENDE BÄNDER



CERNIERE



MORSETTI COORDINATI ▶ 190
COORDINATED CLAMPS
KOORDINIERTE KLEMMEN



B-753

- Cerniera a scatto regolabile vetro/vetro 90°, senza viti a vista. Materiale: Zamak.
- Adjustable 90° glass to glass double action clicking hinge, no visible screws. Material: Zamak.
- Pendeltürband Glas-Glas 90°, mit verstellbarer Nulllagenstellung ohne sichtbare Schrauben. Material: Zamak.

CR - NS - NO

€ BX.217

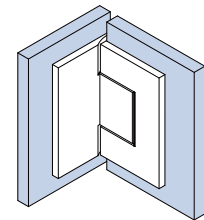
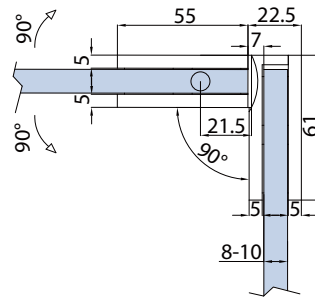

LAVORAZIONE VETRO
 GLASS PREPARATION
 GLASBEARBEITUNG

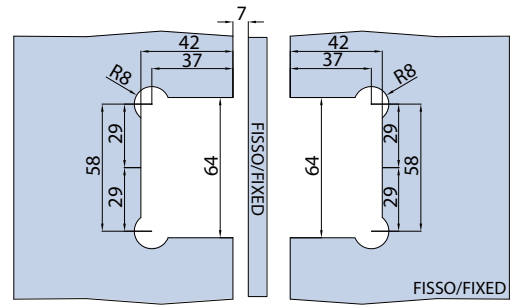
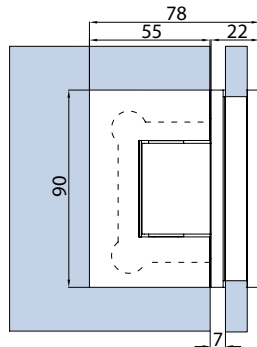

xme624d

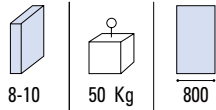

CERNIERE



B-754

- Cerniera a scatto regolabile vetro/vetro 135°, senza viti a vista. Materiale: Zamak.
- Adjustable 135° glass to glass double action clicking hinge, no visible screws. Material: Zamak.
- Pendeltürband Glas-Glas 135°, mit verstellbarer Nulllagenstellung ohne sichtbare Schrauben. Material: Zamak.

CR - NS - NO

€ BX.218

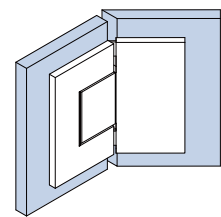
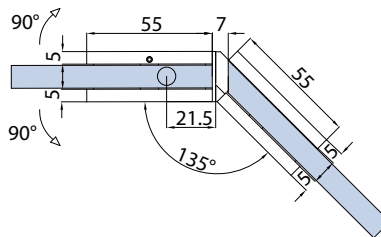

LAVORAZIONE VETRO
 GLASS PREPARATION
 GLASBEARBEITUNG

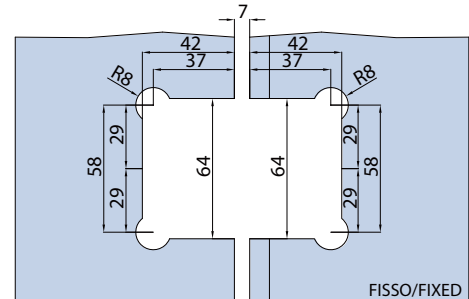
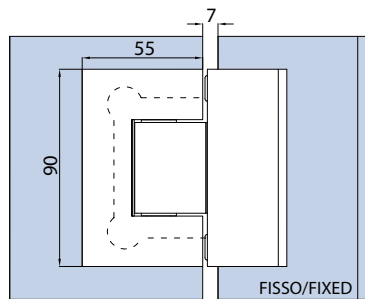

xme624e

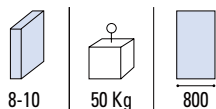

CR
 Cromo lucido
 Polished chrome
 Chrom glänzend

NS
 Nickel satinato
 Satin nickel
 Ähnlich Edelstahl matt

NO
 Nero opaco
 Matt black
 Matt schwarz

CERNIERE A SCATTO

CLICKING HINGES / SELBSTSCHLIESSENDE BÄNDER



- Sistemi per box doccia tutto vetro con cerniere a scatto, senza viti in vista.
- Frameless glass showers systems with double action clicking hinges, with not visible screws.
- Rahmenlosen Duschkabinensysteme aus Glas mit selbstschließende Pendeltürbänder, mit nicht sichtbaren Schrauben.



CERNIERE



MORSETTI COORDINATI ▶ 190
COORDINATED CLAMPS
KOORDINIERT KLEMMEN



B-701

- Cerniera a scatto vetro muro regolabile posizione "0", senza viti a vista. Materiale: ottone.
- Glass to wall double action clicking hinge no visible screws. "0" position adjustable. Material: Brass.
- Pendeltürband Glas-Wand ohne sichtbare Schrauben, mit verstellbarer Nulllagenstellung. Material: Messing.

CR - NS - CP - NO

€ BX.219

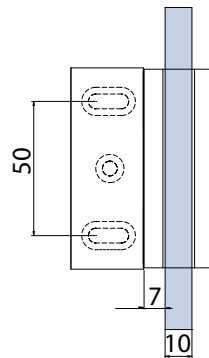
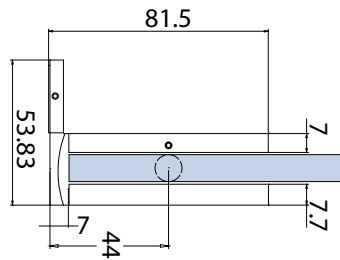
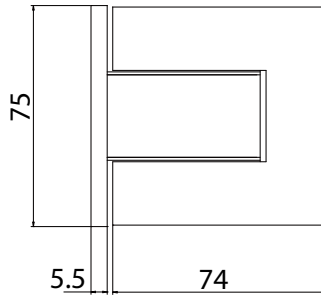

LAVORAZIONE VETRO
 GLASS PREPARATION
 GLASBEARBEITUNG

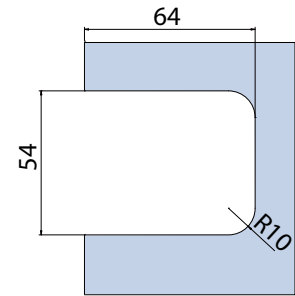

xfb052

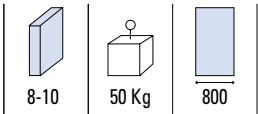

CERNIERE



B-702

- Cerniera a scatto regolabile vetro/vetro senza viti a vista. Materiale: ottone.
- Adjustable glass/glass clicking hinge no visible screws. Material: Brass.
- Duschtürband Glas-Glas ohne sichtbare Schrauben, mit verstellbarer Nulllagenstellung. Material: Messing.

CR - NS - CP

€ BX.220

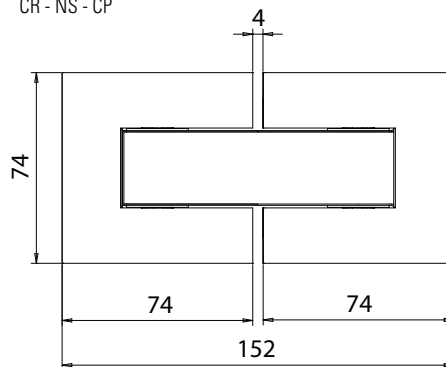

LAVORAZIONE VETRO
 GLASS PREPARATION
 GLASBEARBEITUNG

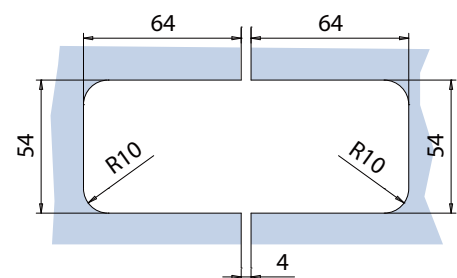
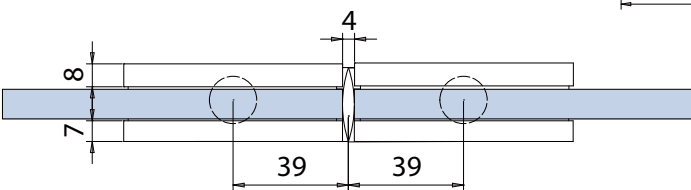

xfb102

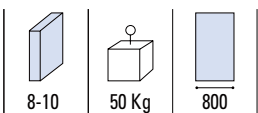

CR
 Cromo lucido
 Polished chrome
 Chrom glänzend

NS
 Nickel satinato
 Satin nickel
 Ähnlich Edelstahl matt

CP
 Cromo perla
 Chrome perla similar Alu
 Chrom perla ähnlich Alu

NO
 Nero opaco
 Matt black
 Matt schwarz

CERNIERE A SCATTO CLICKING HINGES / SELBSTSCHLIESSENDE BÄNDER



CERNIERE





€ BX.227

B-301

- Cerniera a scatto regolabile vetro/muro senza viti a vista. Materiale: Aletta fissaggio ottone. Cerniera Zamak.
- Adjustable glass to wall double action clicking hinge no visible screws. Material: Fixing plate brass. Hinge Zamak.
- Pendeltürband Glas-Wand ohne sichtbare Schrauben, mit verstellbarer Nulllagenstellung. Material: Anschraubplatte Messing. Band Zamak.

CR - NS

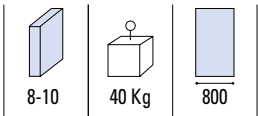
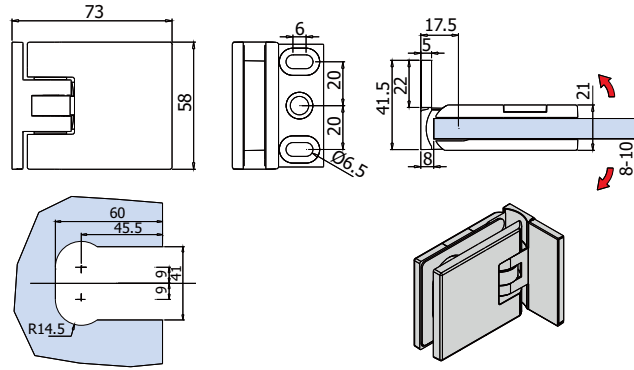

xme301



€ BX.228

B-306

- Cerniera a scatto regolabile vetro/vetro, senza viti a vista. Materiale: Zamak.
- Adjustable glass/glass double action clicking hinge, no visible screws. Material: Zamak.
- Pendeltürband Glas-Glas ohne sichtbare Schrauben, mit verstellbarer Nulllagenstellung. Material: Zamak.

CR - NS

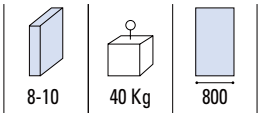
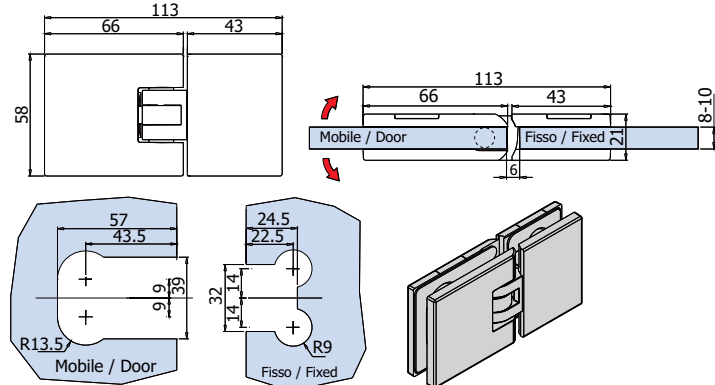

xme301



€ BX.230

L-220

- Cerniera a scatto vetro/vetro regolabile, senza viti in vista. Materiale: Zamak.
- Adjustable glass to glass clicking hinge, with no visible screws. Material: Zamak.
- Verstellbares duschtürband Glas-Glas ohne sichtbare Schrauben. Material: Zamak.

CR - NS - CP

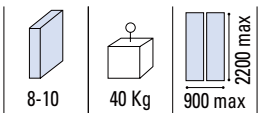
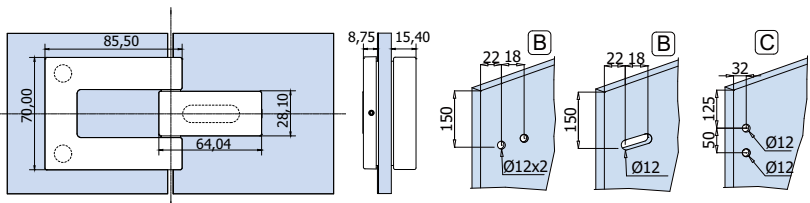
B = Lavorazione vetro alternativa
 Alternative glass preparation
 Alternativ Glasbearbeitung

L-220

CR
 Cromo lucido
 Polished chrome
 Chrom glänzend

NS
 Nickel satinato
 Satin nickel
 Ähnlich Edelstahl matt

CP
 Cromo perla
 Chrome perla similar Alu
 Chrom perla ähnlich Alu

CERNIERE

CERNIERE A SCATTO

CLICKING HINGES / SELBSTSCHLIESSENDE BÄNDER



B-100

- Cerniera a scatto vetro/muro, regolabile. Materiale: Ottone.
 - Adjustable glass/wall double action clicking hinge. Material: Brass.
 - Pendeltürband Glas-Wand, mit verstellbarer Nulllagenstellung. Material: Messing.
- CR - NS - NO

€ BX.222

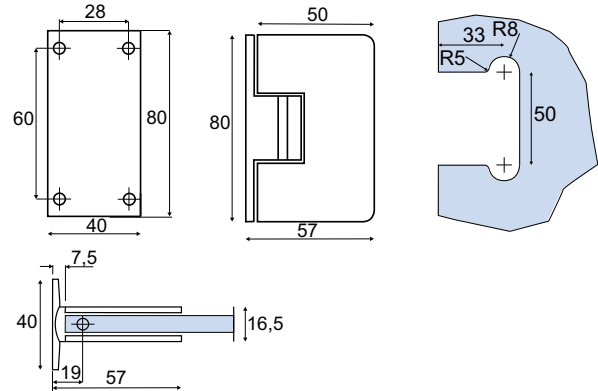
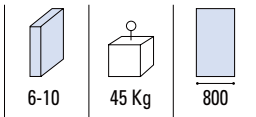

xme401



B-101

- Cerniera a scatto vetro/muro, aletta spostata. Materiale: Ottone.
 - Glass to wall double action clicking hinge with offset base. Material: Brass.
 - Pendeltürband mit einseitiger Anschraubplatte Glas-Wand, mit verstellbarer Nulllagenstellung. Material: Messing.
- CR - NS - NO

€ BX.223

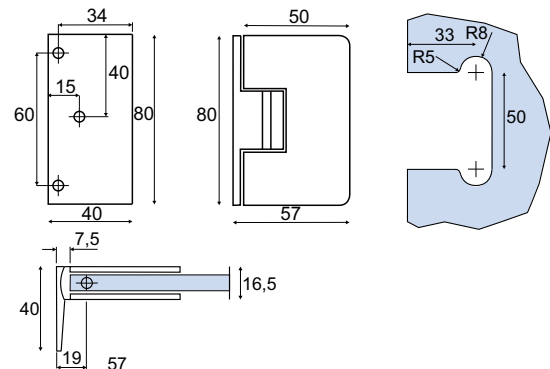
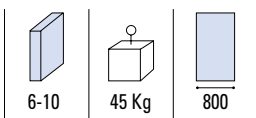

xme401



B-102

- Cerniera a scatto regolabile vetro/vetro, regolabile. Materiale: Ottone.
 - Adjustable glass to glass double action clicking hinge. Material: Brass.
 - Pendeltürband Glas-Glas 180°, mit verstellbarer Nulllagenstellung. Material: Messing.
- CR - NS - NO

€ BX.224

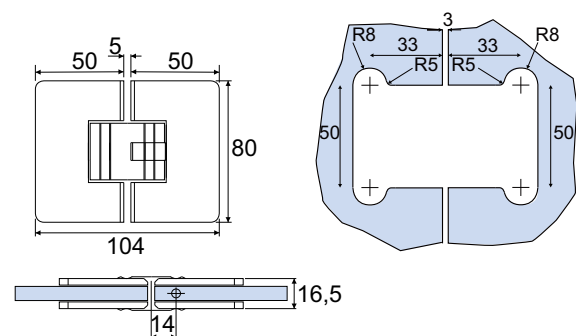
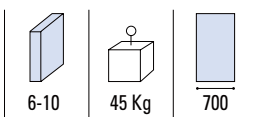

xme401



€ BX.225

B-103

- Cerniera a scatto regolabile vetro/vetro 90°, regolabile. Materiale: Ottone.
- Adjustable 90° glass to glass double action clicking hinge. Material: Brass.
- Pendeltürband Glas-Glas 90°, mit verstellbarer Nulllagenstellung. Material: Messing.

CR - NS

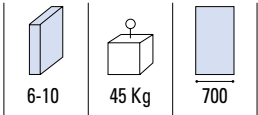
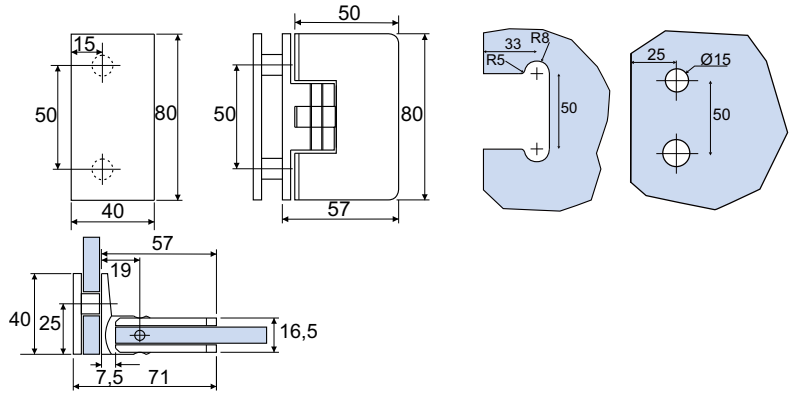

xme401



€ BX.226

B-150

- Cerniera a scatto regolabile vetro/muro, senza viti a vista.
- Adjustable glass/wall double action clicking hinge, without visible screws.
- Pendeltürband Glas-Wand mit verstellbaren Nulllagenstellung, ohne sichtbare Schrauben.

CR - NS

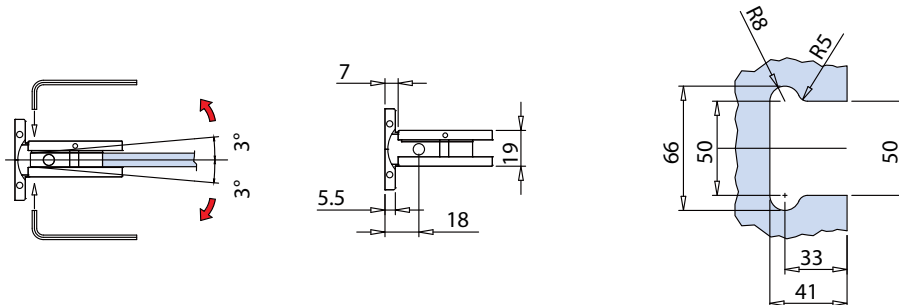
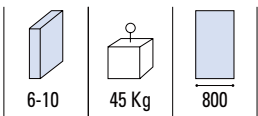
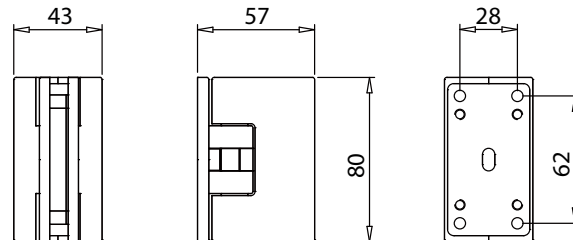

xfb084

CR
Cromo lucido
Polished chrome
Chrom glänzend

NS
Nickel satinato
Satın nickel
Ähnlich Edelstahl matt

NO
Nero opaco
Matt black
Schwarz matt

CERNIERE A SCATTO

CLICKING HINGES / SELBSTSCHLIESSENDE BÄNDER



B-400

- Cerniera a scatto vetro/muro. Materiale: Zamak.
- Glass to wall double action clicking hinge. Material: Zamak.
- Pendeltürband Glas-Wand. Material: Zamak.

CR - NS

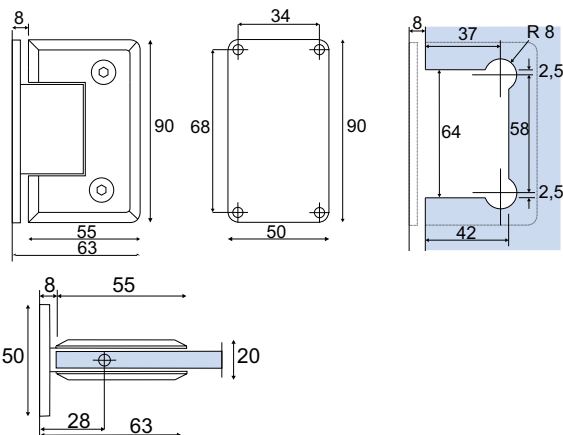

€► BX.231

xme403

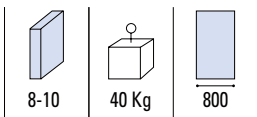

B-401

- Cerniera a scatto vetro/muro. Materiale: Zamak.
- Glass to wall double action clicking hinge with offset base. Material: Zamak.
- Pendeltürband Glas-Wand. Material: Zamak.

CR - NS

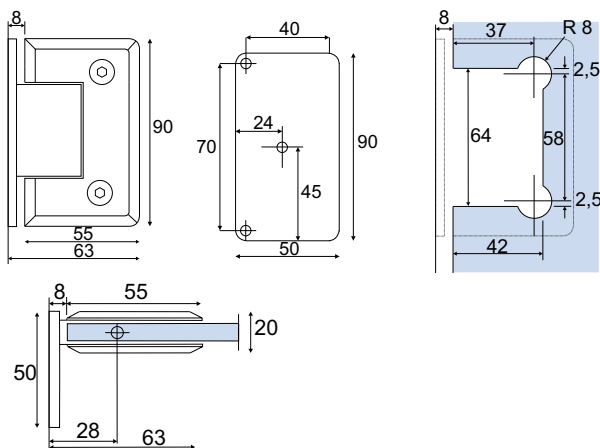

€► BX.232

xme403

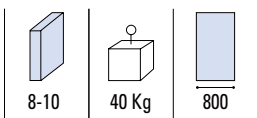

B-402

- Cerniera a scatto vetro/vetro. Materiale: Zamak.
- Glass to glass double action clicking hinge. Material: Zamak.
- Pendeltürband Glas-Glas. Material: Zamak.

CR - NS

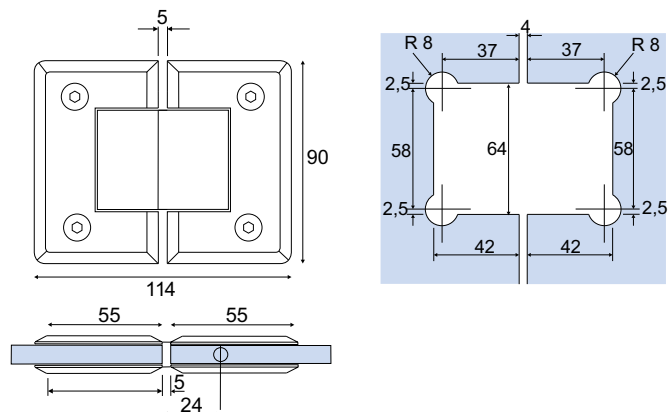

€► BX.233

xme403

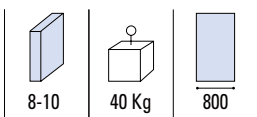

CERNIERE



MORSETTI COORDINATI ▶ 190
COORDINATED CLAMPS
KOORDINIERTE KLEMMEN

€ BX.234



B-405

- Cerniera a scatto vetro/vetro 90°. Materiale: Zamak.
- Glass to glass double action clicking hinge 90°. Material: Zamak.
- Pendeltürband Glas-Glas 90°, beidseitig öffnend. Material: Zamak.

CR - NS

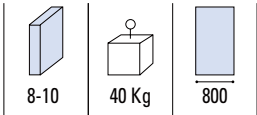
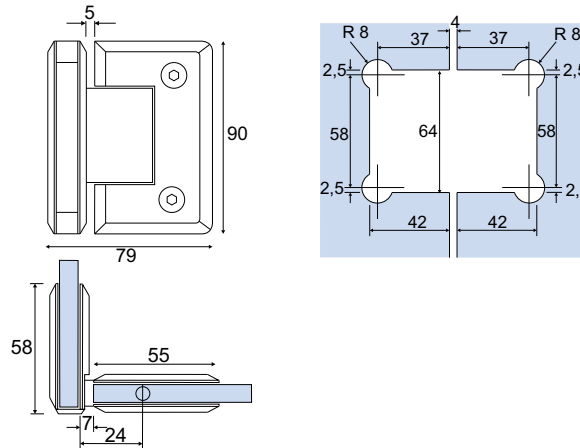

xme403



CERNIERE

CR
 Cromo lucido
 Polished chrome
 Chrom glänzend

NS
 Nickel satinato
 Satin nickel
 Ähnlich Edelstahl matt

CERNIERE A SCATTO IN BATTUTA

**CLICKING HINGES PULL TO OPEN FOR CONTINUOUS SEALS / ANSCHLAGTÜRBÄNDER
FÜR DURCHGEHENDE DICHTUNG**



- Sistemi per box doccia tutto vetro con cerniere a scatto, profili di battuta e a pavimento.
- Frameless glass showers systems with single action clicking hinges, door stop profiles and floor profiles.
- Rahmenlosen Duschkabinen-systeme aus Glas mit selbstschließenden Anschlagtürbänder, Türanschlagsprofile und Bodenprofile.



CERNIERE



MORSETTI COORDINATI ▶ 190
COORDINATED CLAMPS
KOORDINIERTE KLEMMEN

€ BX.235



B-201

- Cerniera a scatto vetro/muro apertura a tirare. Materiale: Ottone.
 - Glass to wall single action clicking hinge, pull to open. Material: Brass
 - Anschlagtürband Glas-Wand nach außen öffnend. (Selbstschliessende Bänder) Material: Messing.
- CR - NS

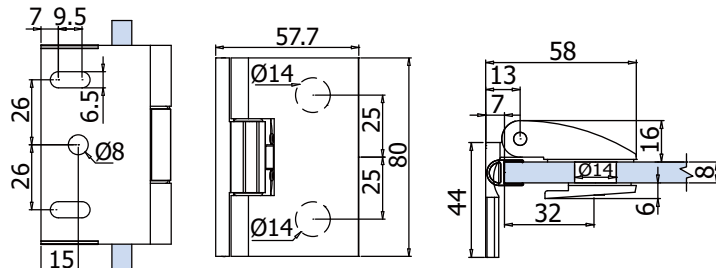

- Con guarnizione B-145
- With gasket B-145
- Mit Dichtung B-145

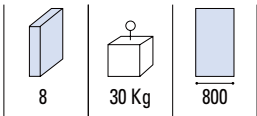
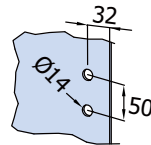

NUOVO MODELLO
IN ZAMA IN ARRIVO
 NEW MODEL ZAMAK
 COMING SOON

xmc015



B-202

- Cerniera a scatto vetro/vetro apertura a tirare. Materiale: Ottone.
 - Glass to glass single action clicking hinge pull to open. Material: Brass.
 - Anschlagtürband Glas-Glas, nach außen hin öffnend. (Selbstschliessende Bänder) Material: Messing.
- CR - NS

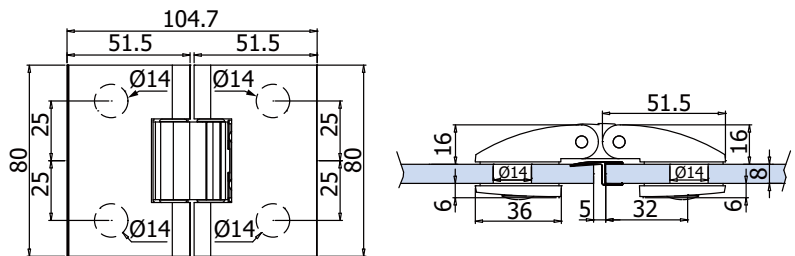

- Con guarnizione B-149
- With gasket B-149
- Mit Dichtung B-149

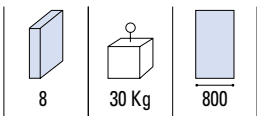
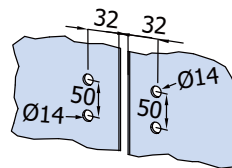

NUOVO MODELLO
IN ZAMA IN ARRIVO
 NEW MODEL ZAMAK
 COMING SOON

xmc015



- Applicazione con profilo battuta P-015 (optional).
- Installation with door stop profile P-015 (optional).
- Verwendung mit Türanschlagsprofil P-015 (optional).

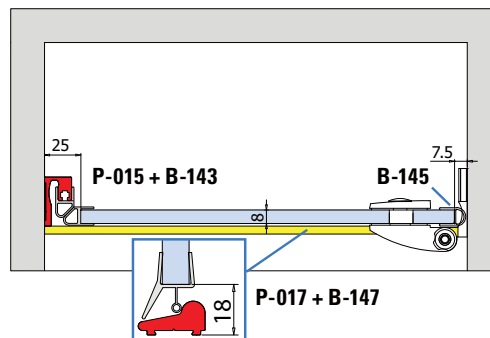

P-015 + B-146

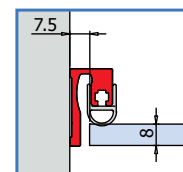

P-015 + P-016 + B-148

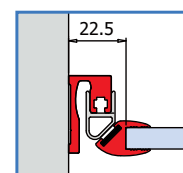

CR
 Cromo lucido
 Polished chrome
 Chrom glänzend

NS
 Nickel satinato
 Satin nickel
 Ähnlich Edelstahl matt

CERNIERE

NEW

CERNIERE CON ALZATA INTERNO/ESTERNO

SWING DOOR HINGES WITH LIFT-LOWER FUNCTION / PENDELTÜRBÄNDER MIT HEBE-SENK FUNKTION



CERNIERE





MORSETTI COORDINATI ▶ 190
COORDINATED CLAMPS
KOORDINIERTE KLEMMEN



- Cerniera vetro/muro con alzata in apertura senza viti a vista. Materiale: Zamak.
 - Swing door hinge glass to wall with lift-lower function at opening, no visible screws. Material: Zamak.
 - Pendeltürband Wand-Glas mit Hebe-Senk Funktion ohne sichtbare Schrauben. Material: Zamak.
- CR - NS - NO

- **APERTURA 90°**
- **ESTERNA E INTERNA**
- **90° OPENS IN-AND**
- **OUTWARDS**
- **90° BEIDSEITIG**
- **ÖFFNEND**

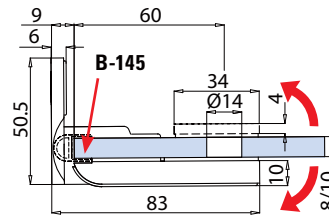
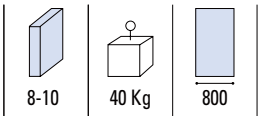
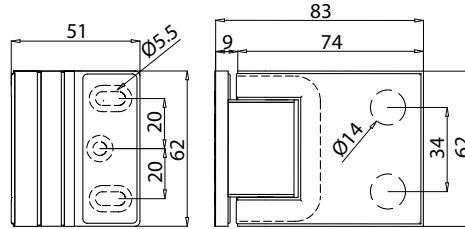

- Consigliato con guarnizione B-145
- Recommended with gasket B-145
- Empfohlen mit Dichtung B-145

B-551 DX-SX €▶BX.237

- Versione con coperchietto
- With cover plate
- Mit Klemmplatte

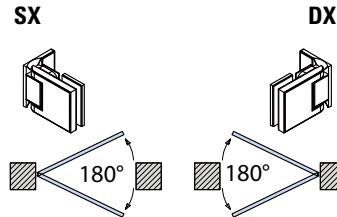
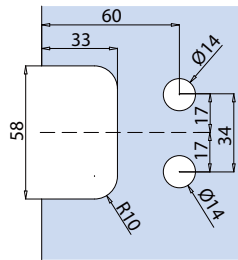
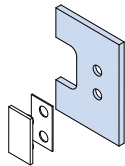

CERNIERE

B-553 DX-SX €▶BX.238

- Versione con tappi filo vetro
- With flush screws
- Flächenbündig

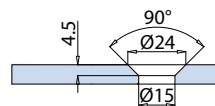
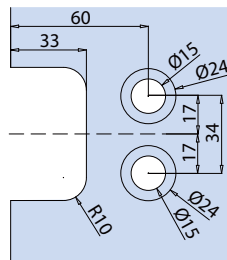
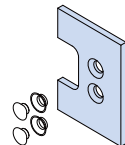

- Regolazione del punto "0"
- Adjustable
- Nulllageverstellung

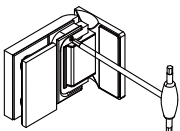

xme617

CR
 Cromo lucido
 Polished chrome
 Chrom glänzend

NS
 Nickel satinato
 Satin nickel
 Ähnlich Edelstahl matt

NO
 Nero opaco
 Matt black
 Matt schwarz

NEW

CERNIERE CON ALZATA ESTERNO/INTERNO
SWING DOOR HINGES WITH LIFT-LOWER FUNCTION / PENDELTÜRBÄNDER MIT HEBE-SENK FUNKTION



CERNIERE



MORSETTI COORDINATI ▶ 190
COORDINATED CLAMPS
KOORDINIERTE KLEMMEN



- Cerniera vetro/vetro con alzata in apertura senza viti a vista. Materiale: Zamak.
 - Swing door hinge glass to glass with lift-lower function, no visible screws. Material: Zamak.
 - Pendeltürband Glas-Glas mit hebe-senk funktion ohne sichtbare Schrauben. Material: Zamak.
- CR - NS - NO

- **APERTURA 90° ESTERNA E INTERNA**
- **90° OPENS IN-AND OUTWARDS**
- **90° BEIDSEITIG ÖFFNEND**

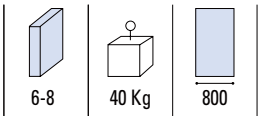
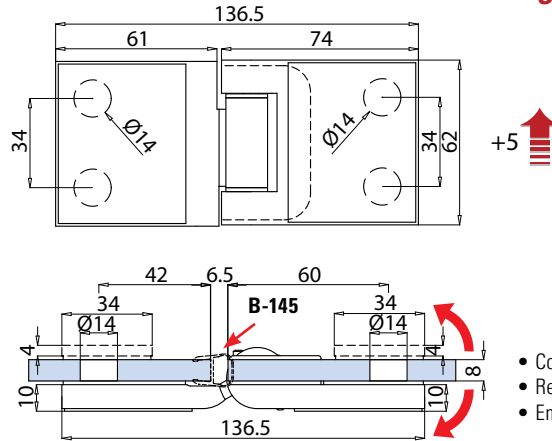

- Consigliato con guarnizione B-145
- Recommended with gasket B-145
- Empfohlen mit Dichtung B-145

B-552 DX-SX €▶ BX.239

- Versione con coperchietto
- With cover plate
- Mit Klemmplatte

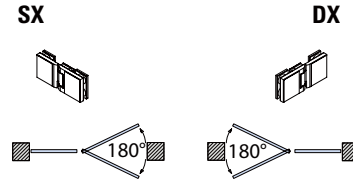
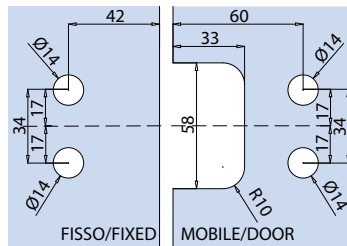
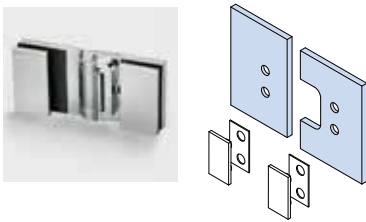

B-554 DX-SX €▶ BX.240

- Versione con tappi filo vetro
- With flush screws
- Flächenbündig

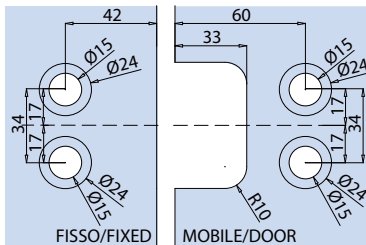
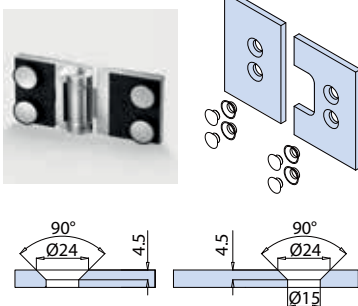

- Regolazione del punto "0"
- Adjustable
- Nulllageverstellung

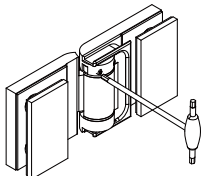

xme617A

- | | | |
|--|--|---|
| CR
Cromo lucido
Polished chrome
Chrom glänzend | NS
Nickel satinato
Satin nickel
Ähnlich Edelstahl matt | NO
Nero opaco
Matt black
Matt schwarz |
|--|--|---|

CERNIERE

NEW

CERNIERE CON ALZATA IN APERTURA

HINGES WITH LIFT-LOWER FUNCTION / BÄNDER MIT HEBE-SENK FUNKTION



CERNIERE

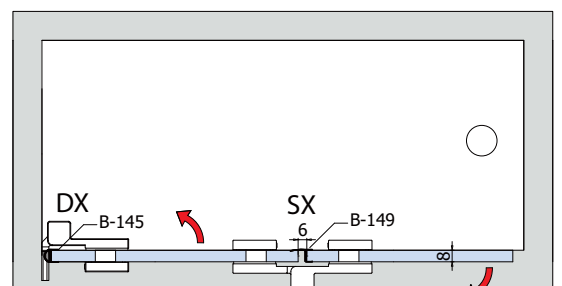



MORSETTI COORDINATI ▶ 190
COORDINATED CLAMPS
KOORDINIERTE KLEMMEN

€ BX.241

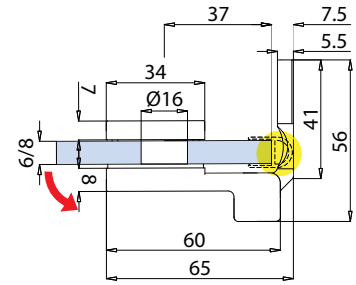
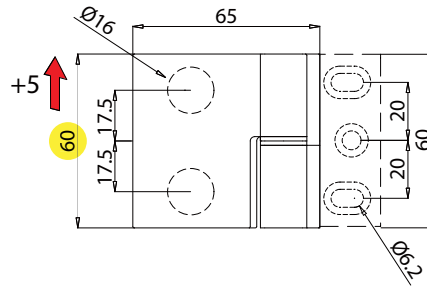

B-501 DX-SX

- Cerniera vetro/muro con alzata in apertura senza viti a vista. Materiale: Zamak.
- Hinge wall to glass with lift-lower function at opening, no visible screws. Material: Zamak.
- Band Wand-Glas mit hebe-senk funktion ohne sichtbare Schrauben. Material: Zamak.

CR - NS

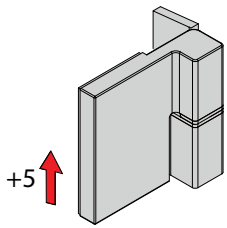
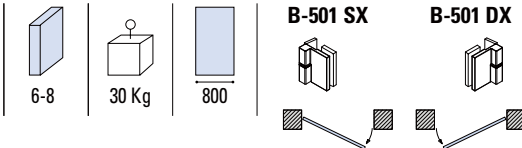
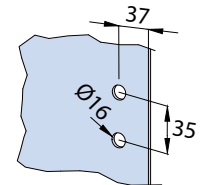

- Consigliato con guarnizione B-145
- Recommended with gasket B-145
- Empfohlen mit Dichtung B-145

 NUOVO MODELLO
 IN ARRIVO
 NEW MODEL
 COMING SOON

xme616

CERNIERE



B-502 DX-SX

- Cerniera vetro/vetro con alzata in apertura senza viti a vista. Materiale: Zamak.
- Hinge glass to glass with lift-lower function, no visible screws. Material: Zamak.
- Band Glas-Glas mit hebe-senk funktion ohne sichtbare Schrauben. Material: Zamak.

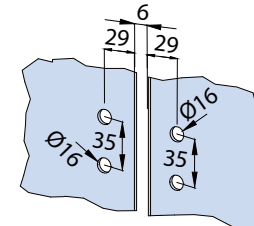
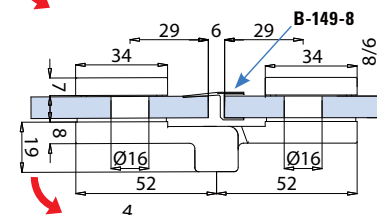
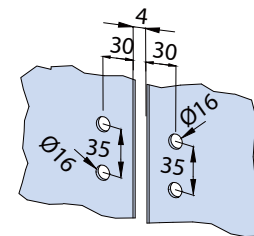
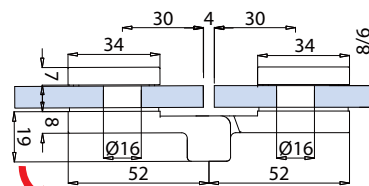
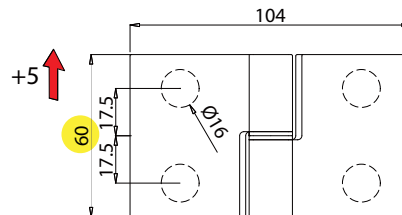
CR - NS

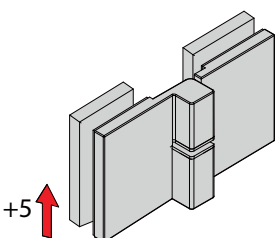
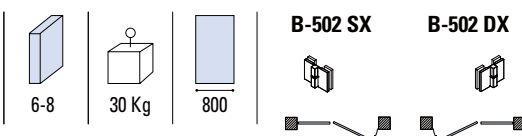

- Consigliato con guarnizione B-149-8
- Recommended with gasket B-149-8
- Empfohlen mit Dichtung B-149-8

 NUOVO MODELLO
 IN ARRIVO
 NEW MODEL
 COMING SOON

xme616a

CR
 Cromo lucido
 Polished chrome
 Chrom glänzend

NS
 Nickel satinato
 Satin nickel
 Ähnlich Edelstahl matt

CERNIERE LIBERE IN BATTUTA

HINGES FOR CONTINUOUS SEALS / ANSCHLAGTÜRBÄNDER FÜR DURCHGEHENDER DICHTUNG

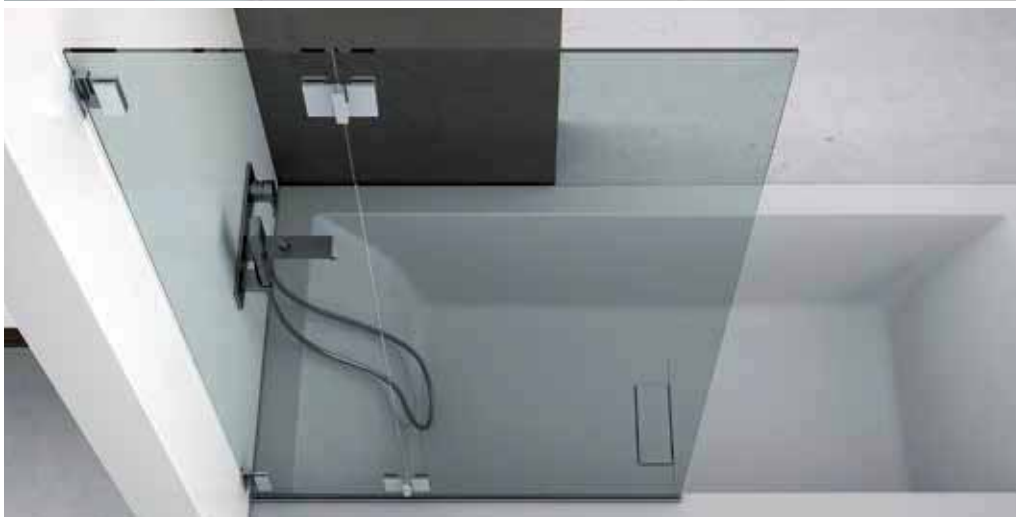

- Sistemi per box doccia tutto vetro con cerniere libere, profili di battuta e a pavimento.
- Frameless glass showers systems with free hinges, door stop profiles and floor profiles.
- Rahmenlosen Duschkabine-systeme aus Glas mit freie Anschlagtürbänder, Türanschlagsprofile und Bodenprofile.



MORSETTI COORDINATI ▶ 190
COORDINATED CLAMPS
KOORDINIERTE KLEMMEN

€ BX.243



B-711

- Cerniera vetro muro. Materiale: zama.
- Glass to wall single action hinge. Material: zamak.
- Anschlagtürband Glas-Wand. Material: Zamak.

CR - NO

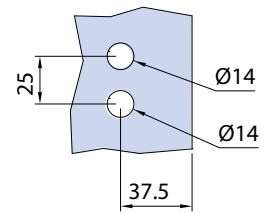
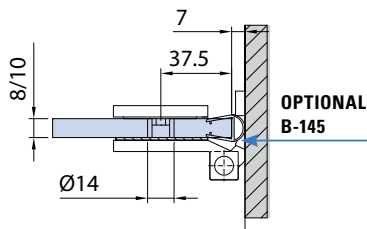
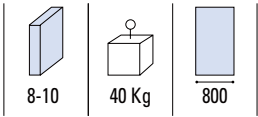
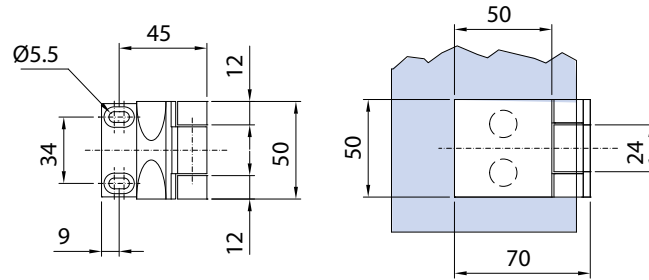

xfb-110



B-712

- Cerniera vetro/vetro. Materiale: zama.
- Glass to glass hinge. Material: zamak.
- Duschtürband Glas-Glas. Material: Zamak.

CR - NO

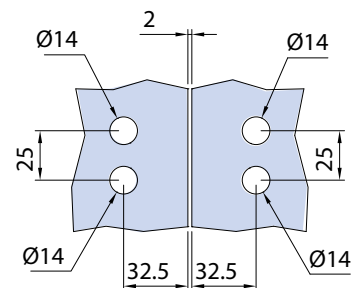
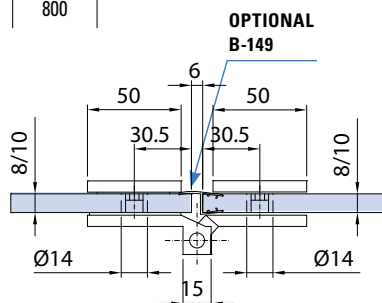
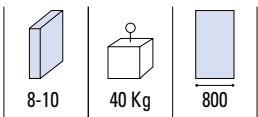
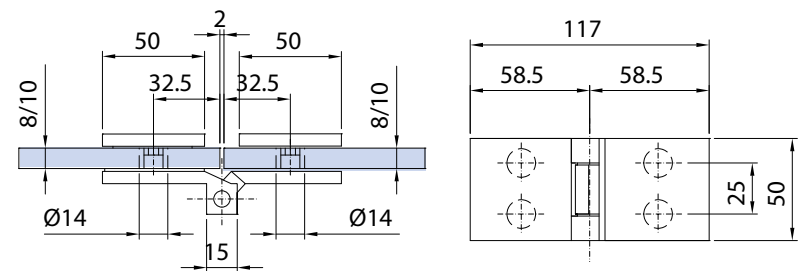

xfb-111

CR
 Cromo lucido
 Polished chrome
 Chrom glänzend

NO
 Nero opaco
 Matt black
 Matt schwarz

NEW

CERNIERE LIBERE IN BATTUTA

HINGES FOR CONTINUOUS SEALS / ANSCHLAGTÜRBÄNDER FÜR DURCHGEHENDER DICHTUNG



CERNIERE

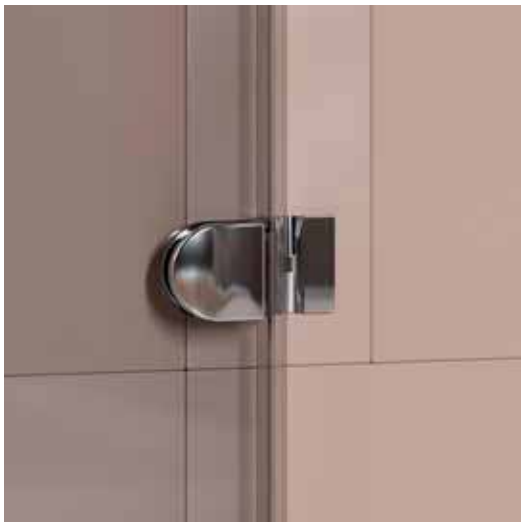

- Sistemi per box doccia tutto vetro con cerniere libere, profili di battuta e a pavimento.
- Frameless glass showers systems with free hinges, door stop profiles and floor profiles.
- Rahmenlosen Duschkabinen-systeme aus Glas mit freie Anschlagtürbänder, Türanschlagsprofile und Bodenprofile.

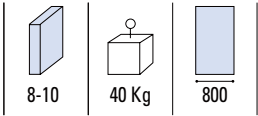

B-621

- Cerniera vetro muro senza viti a vista. Materiale: Zamak.
- Glass to wall single action hinge no visible screws. Material: Zamak.
- Anschlagtürband Glas-Wand ohne sichtbare Schrauben. Material: Zamak.

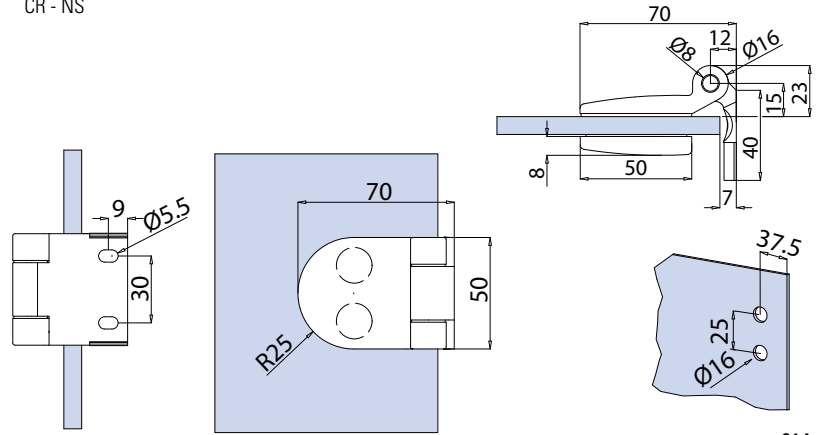
CR - NS

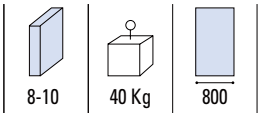

xme614

B-622

- Cerniera vetro/vetro senza viti a vista. Materiale: Zamak.
- Glass to glass hinge no visible screws. Material: Zamak.
- Duschtürband Glas-Glas ohne sichtbare Schrauben. Material: Zamak.

CR - NS

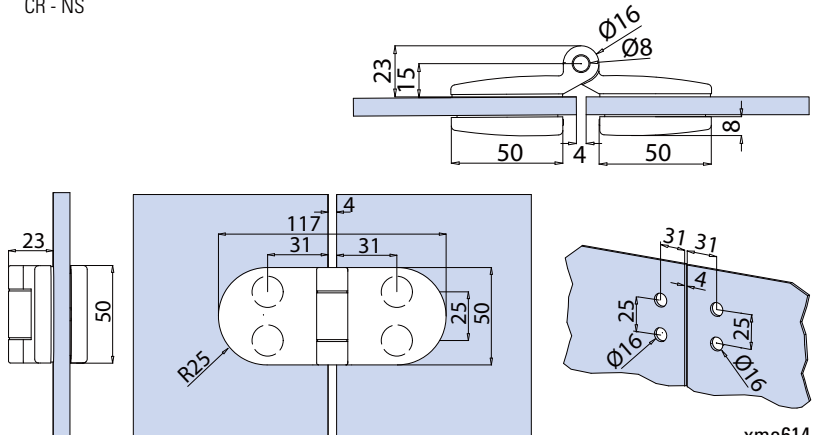

xme614

CR
 Cromo lucido
 Polished chrome
 Chrom glänzend

NS
 Nickel satinato
 Satin nickel
 Ähnlich Edelstahl matt

MORSETTI COORDINATI ▶ 190
COORDINATED CLAMPS
KOORDINIERTE KLEMMEN

▶ BX.247



B-105

- Cerniera vetro/muro apertura a tirare. Materiale: ottone.
 - Glass to wall hinge, pull to open. Material: brass.
 - Duschtürband Glas-Wand nach außen öffnend. Material: Messing.
- CR - NS

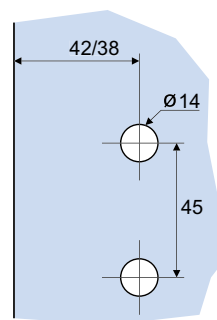
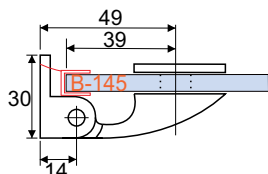
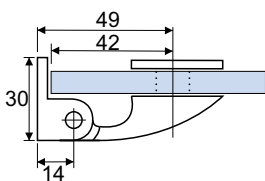
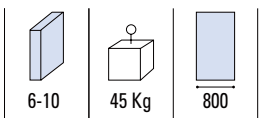
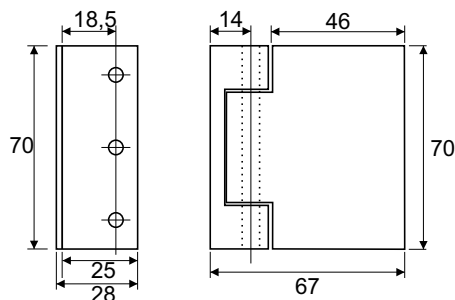

xme336

CERNIERE

▶ BX.248



B-104

- Cerniera vetro/vetro. Materiale: ottone.
 - Glass to glass hing. Material: brass.
 - Duschtürband Glas-Glas. Material: Messing.
- CR - NS

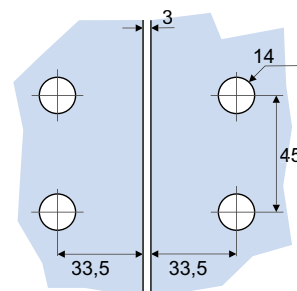
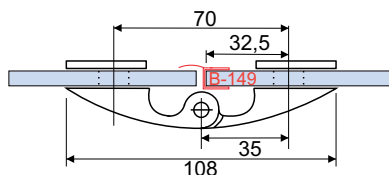
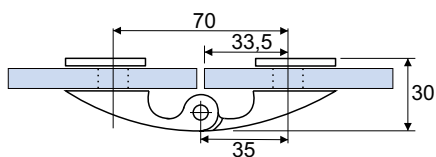
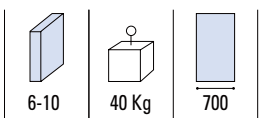
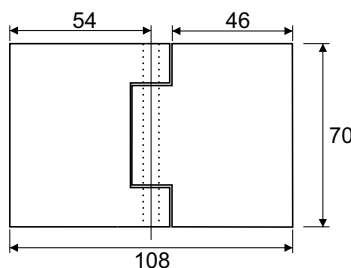

xme336

CR
Cromo lucido
Polished chrome
Chrom glänzend
148

NS
Nickel satinato
Satin nickel
Ähnlich Edelstahl matt



CERNIERE

BX-2100 BILICO



CERNIERE

- Sistema per box doccia tutto vetro con cerniere Bilico per porte pivotanti. Materiale: alluminio finitura cromo lucido.
- Frameless glass shower system with Bilico hinges for pivot doors. Material: aluminium Polished Chrome.
- Rahmenlose Duschkabinesystem aus Glas mit Bilico Bänder für Drehtüren. Material: Aluminium Chrom poliert.

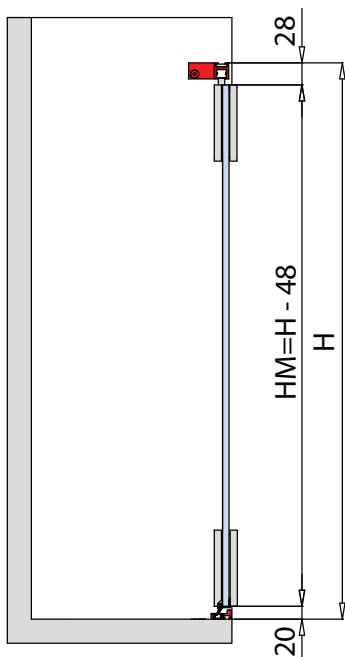

CERNIERE



SET 2 €>BX.201

SET 4 €>BX.202

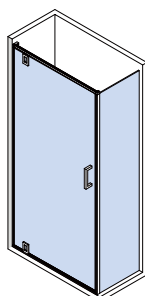
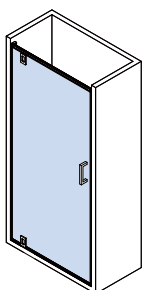

BX-2100 BILICO



BX-2100 SET 2

€ BX.201

DOCCIA IN NICCHIA / NICHE SHOWER / NISCHENDUSCHE

P-F09 (2x)



P-F11 (1x)



P-026 (1x)



B-304 (2x)



OPTIONAL



P-019 (2x)



P-F12 (1x)



R-30 (1x)



P-018-M (1x)



P-018-B (1x)

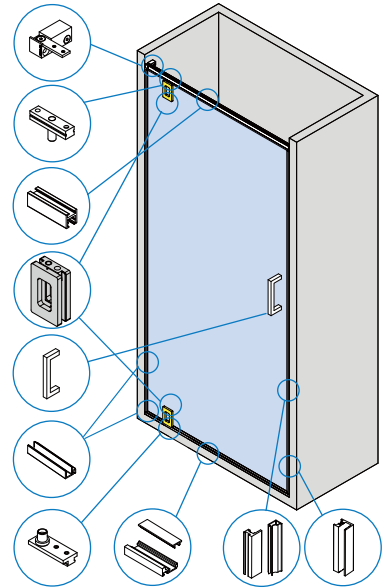

xme294-1

CERNIERE

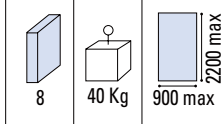
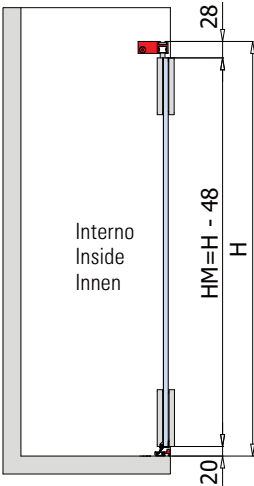

Fin. / Fin. / Oberf.

CR
Cromo lucido
Polished chrome
Chrom glänzend

Profili vetro fisso
Profiles for fixed panels
Profil für Festverglasung... ▶ 170

COMPONENTI / COMPONENTS / EINZELTEILE

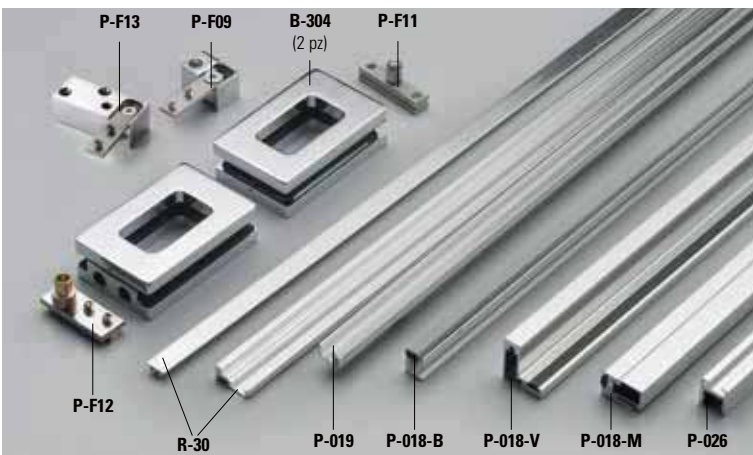

BX-2100 SET 4

€ BX.202

DOCCIA CON SPALLA IN VETRO / CORNER SHOWER WITH 2 FIXED PANEL / ECKDUSCHE MIT 2 FESTSTEHENDEN GLASTAFELN

P-F13 (1x)



P-F09 (1x)



P-F11 (1x)



BX-PF-01

OPTIONAL



B-136

OPTIONAL



OPTIONAL



B-304 (2x)



P-019 (2x)



P-F12 (1x)



P-018-V (1x)



P-018-B (1x)

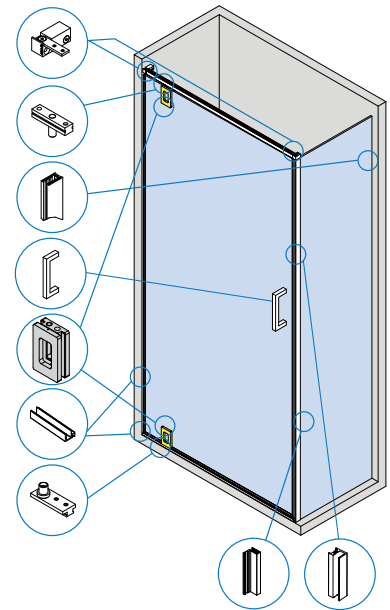

xme294-3

HV = H - 48
 LV = LP - 15

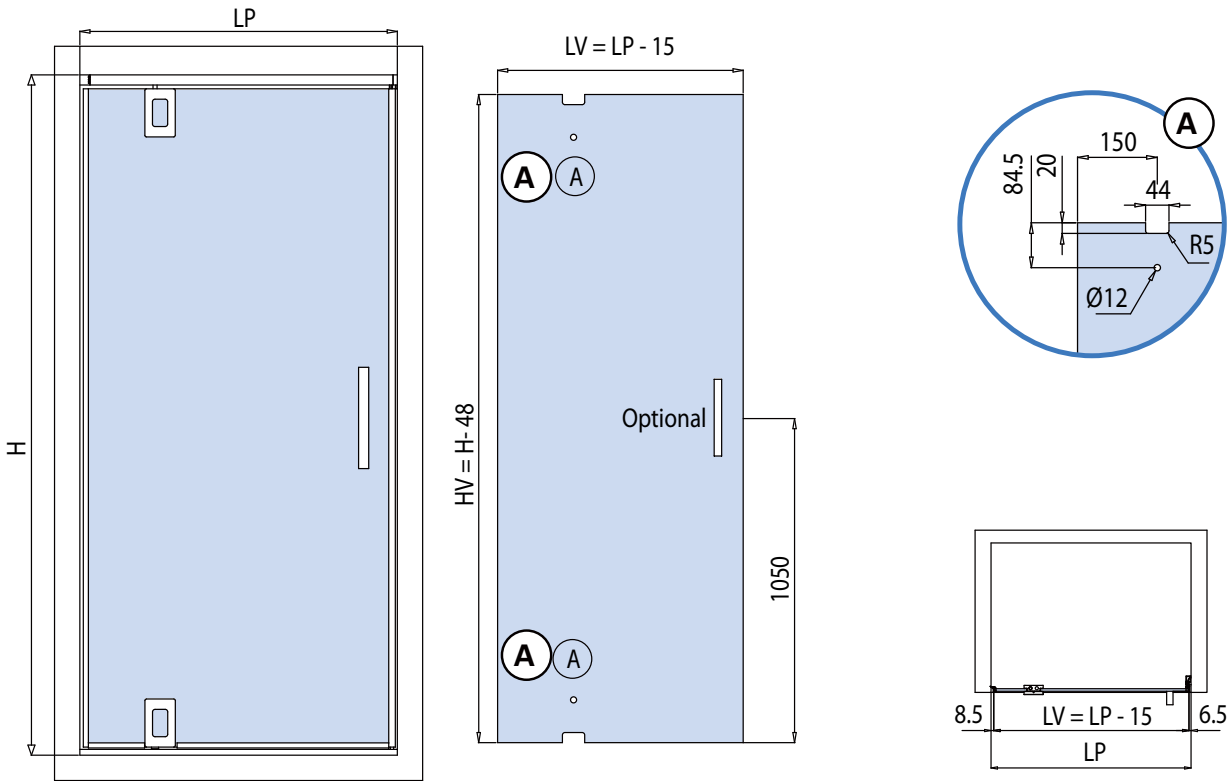

CERNIERE

HV = H - 48
 LM = LP - 36
 HF = H - 22
 LF = LP - 28

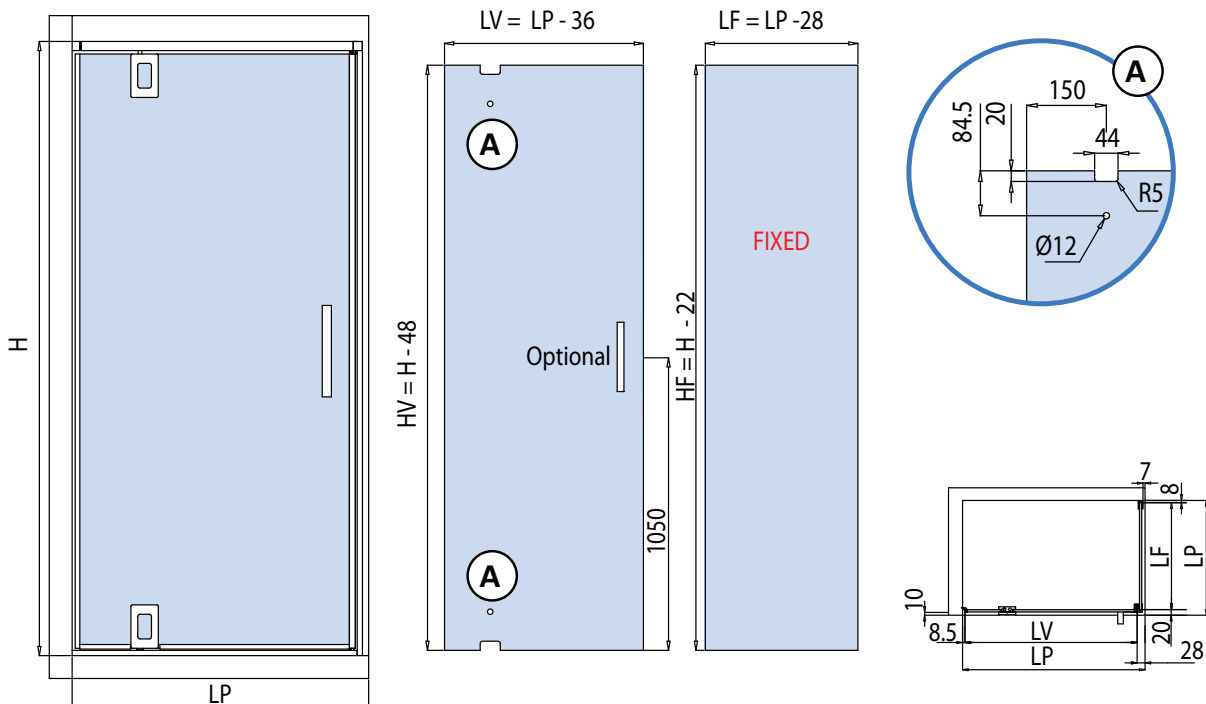

xme388

L / LP
 Piatto
 Shower tray
 Duschtaße

LF
 Larghezza vetro fisso
 Side fixed glass width
 Seitenteil Breite

LV
 Larghezza vetro mobile
 Sliding glass width
 Schiebeflügel Breite

HM
 Altezza vetro mobile
 Sliding glass height
 Schiebeflügel Höhe

H
 Altezza doccia
 Shower height
 Duschkabine Höhe

HF
 Altezza vetro fisso
 Side fixed glass height
 Seitenteil Höhe

BX-2100 BILICO

COMPONENTI / COMPONENTS / EINZELTEILE

P-026 €▶ BX.204



- Binario
- Track profile
- Laufschiene

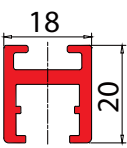

Cod.	Fin./Fin./Oberf.
P-026-1000 mm	CR

x fb-062

P-018-M €▶ BX.205



- Profilo battuta a muro per porta battente compreso di magnete
- Door stop profile for hinged door, with magnetic gasket
- Türanschlagsprofil mit Magnet Dichtung

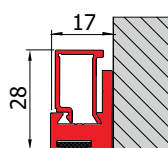

Cod.	Fin./Fin./Oberf.
P-018-M-2500 mm	CR

x me-305

P-018-B €▶ BX.206



- Profilo bordo vetro con magnete per chiusura a battuta con profilo P-018-M o P-018-V
- Closure profile with magnetic seal for profiles P-018-M or P-018-V
- Vertikal Rahmenprofil für Magnetische Zuhaltung mit Profile P-018-M oder P-018-V

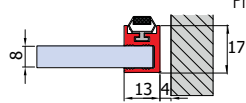

Cod.	Fin./Fin./Oberf.
P-018-B-2500 mm	CR

x me-305

P-018-V €▶ BX.207



- Profilo battuta a vetro per porta battente compreso di magnete
- Door stop profile glass installation for hinged door, with magnetic gasket
- Türanschlagsprofil Glasmontage mit Magnet Dichtung

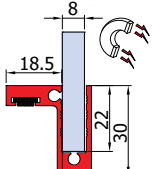

Cod.	Fin./Fin./Oberf.
P-018-V-2500 mm	CR

x me-305

P-019 €▶ BX.208

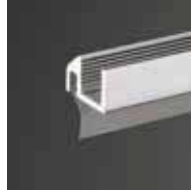

- Profilo gocciolatoio con guarnizione in PVC trasparente da 9 mm
- Splash guard profile with drip flat 9 mm seal transparent PVC
- Schwallenschutz Profil mit trasparent PVC Dichtung 9 mm

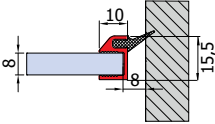

Cod.	Fin./Fin./Oberf.
P-019-2200 mm	CR

x me-305

R-30 €▶ BX.209



- Profilo a terra
- Floor profile
- Bodenprofil

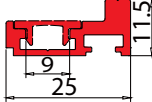

Cod.	Fin./Fin./Oberf.
R-30-1000 mm	CR

x fb-063

B-304 €▶ BX.210



- Cerniera alto/basso in abbinamento a kit BX-2100
- Top/bottom hinge, component of BX-2100
- Oberes / unteres Band, Einzelteile BX-2100 CR

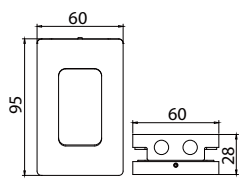

x fb-063

P-F09 €▶ BX.213



- Attacco a parete per binario
- Wall connector for track profile
- Wandhalter für Laufschiene



x fb-063

P-F13 €▶ BX.214



- Attacco a vetro per binario
- Glass connector for track profile
- Glashalter für Laufschiene

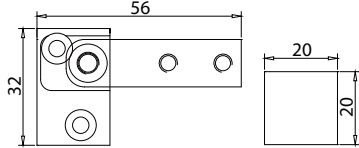

x fb-063

P-F11 €▶ BX.211



- Perno superiore in abbinamento a binario P-026
- Top pin for track profile P-026
- Oberer Zapfen für Laufschiene P-026

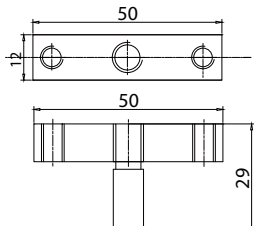

x fb-063

P-F12 €▶ BX.212



- Perno inferiore in abbinamento a profilo a terra R-30
- Bottom pin for floor profile R-30
- Unterer Zapfen für Bodenprofil R-30

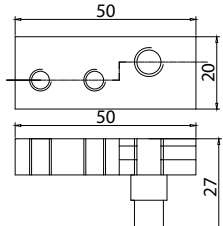

x fb-063

CERNIERE



CERNIERE

B-305

PIVOT ALTO/BASSO (BILICO) / TOP/BOTTOM PIVOT HINGES / OBERE/UNTERE PIVOT BÄNDER

- Sistema per box doccia tutto vetro con cerniera a scatto alto/basso, regolabile, senza vetri a vista.
- Frameless glass showers systems with adjustable pivot clicking hinges, with no visible screws.
- Rahmenlose Duschkabinesystem aus Glas mit oberem/unterem Band, mit Nullageverstellung, ohne sichtbare Schrauben.

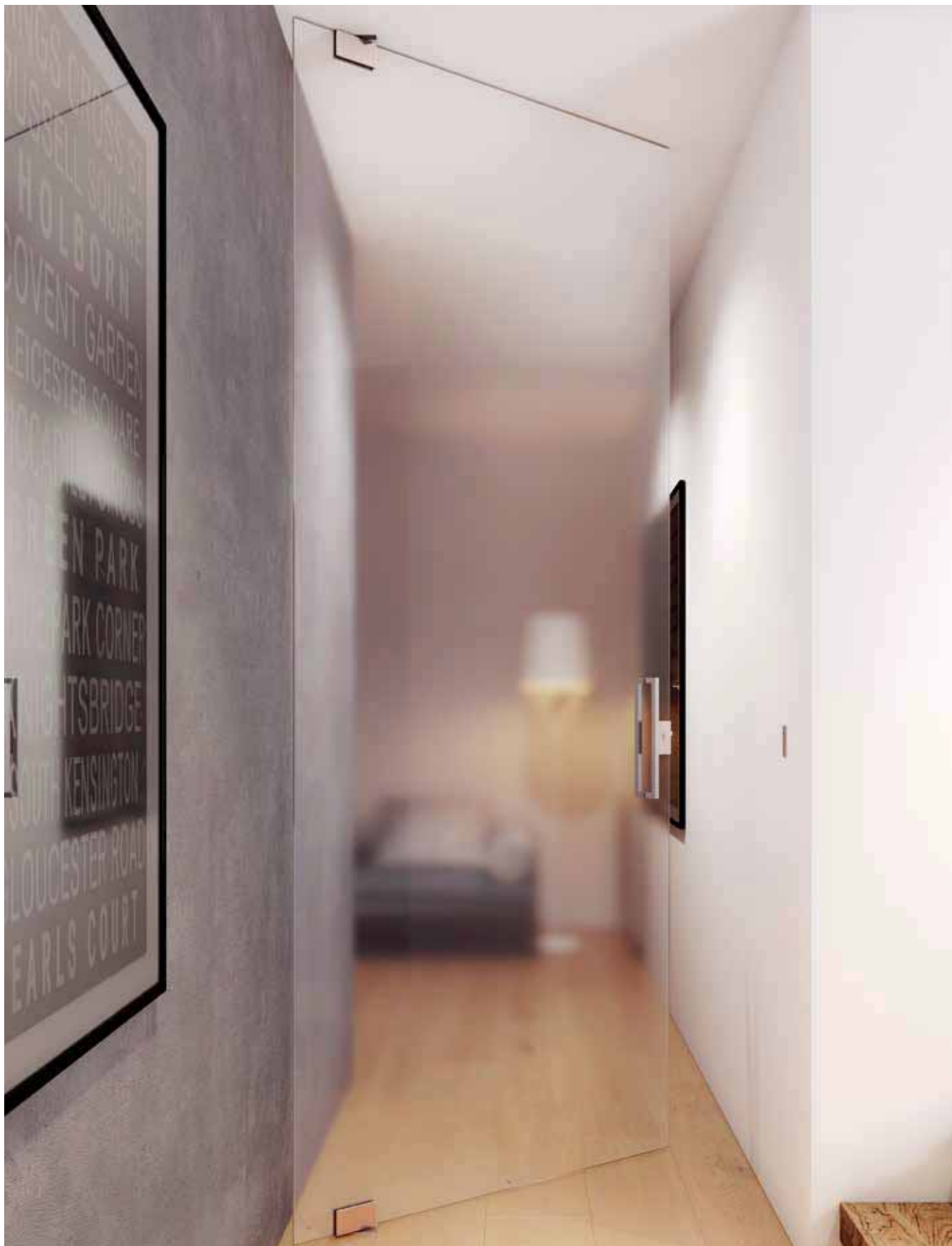

CERNIERE

B-305 €►BX.221

- Cerniera a scatto alto/basso, regolabile, senza viti a vista. Materiale: ottone
 - Adjustable pivot clicking hinge, no visible screws. Material: Brass
 - Oberes/unteres Band, mit Nulllageverstellung, ohne sichtbare Schrauben. Material: Messing
- CR - NS - CP - NO

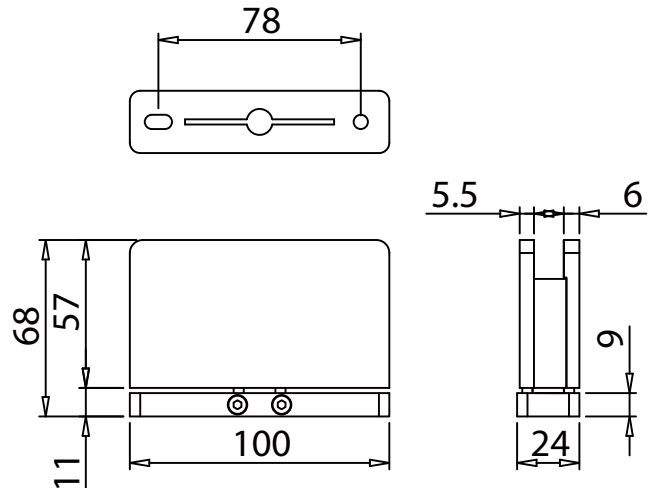

CERNIERE

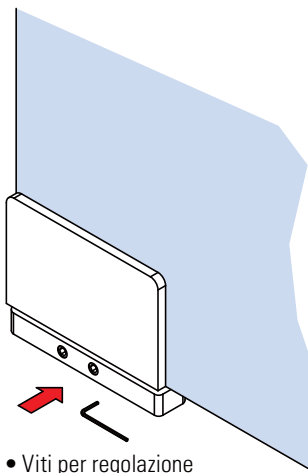
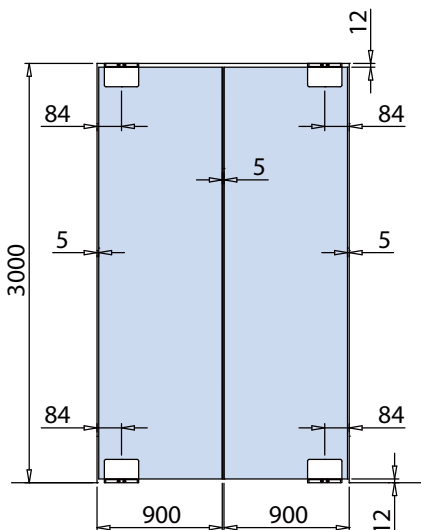
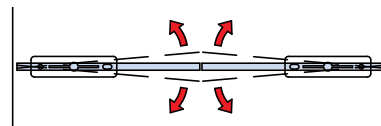
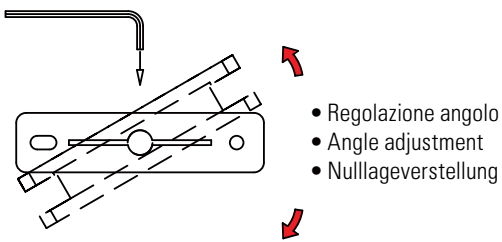

- Viti per regolazione
- Screws for adjustment
- Schrauben für Verstellung

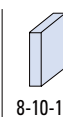
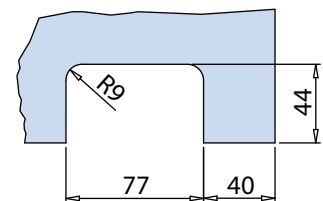
 LAVORAZIONE VETRO
 GLASS PREPARATION
 GLASBEARBEITUNG

8-10-12

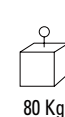

80 Kg

xfb085

CR
 Cromo lucido
 Polished chrome
 Chrom glänzend

NS
 Nickel satinato
 Satin nickel
 Ähnlich Edelstahl matt



CP
 Cromo perla
 Chrome perla similar Alu
 Chrom perla ähnlich Alu

NO
 Nero opaco
 Matt black
 Matt schwarz

B-303 BILICA

€ ▶ BX.229

DOCCIA IN NICCHIA / NICHE SHOWER / NISCHENDUSCHE

 6-8	 35 Kg	 800 max 2000 max	Fin. / Fin. / Oberf. CR Cromo lucido Polished chrome Chrom glänzend
--	--	--	---



CERNIERE

- Sistema per box doccia tutto vetro con cerniere Bilica per porte pivotanti.
- Frameless glass shower system with adjustable Bilica clicking hinges for pivot doors.
- Rahmenlose Duschkabinesystem aus Glas mit Bilica Bänder für Drehtüren.

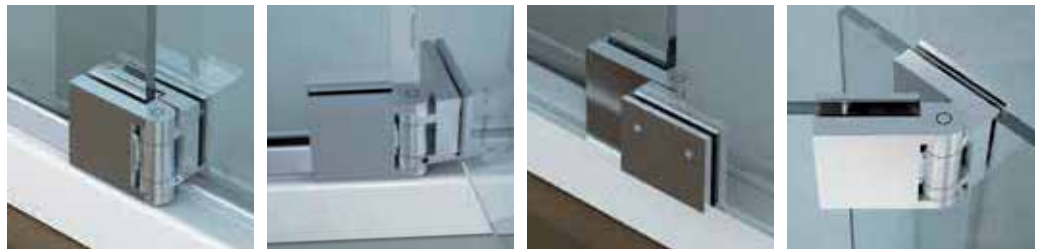

ALCUNE TIPOLOGIE DI APPLICAZIONE / SOME APPLICATION TYPOLOGIES / EINIGEN KOMPOSITIONSMÖGLICHKEITEN DES SYSTEM

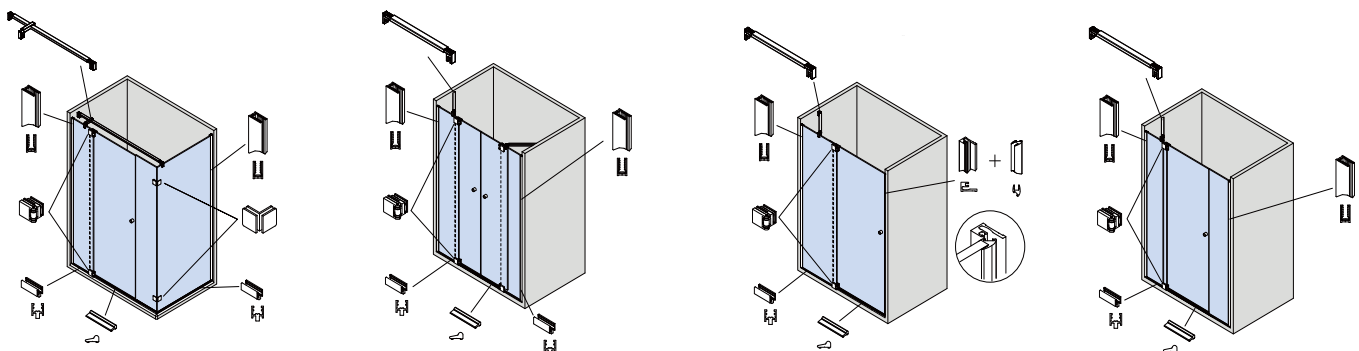

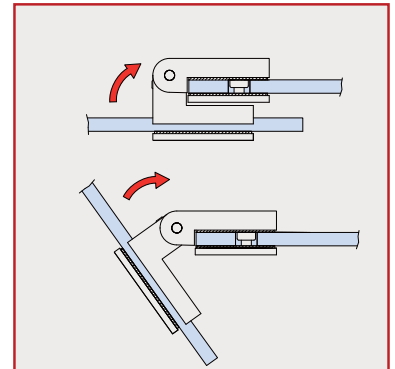
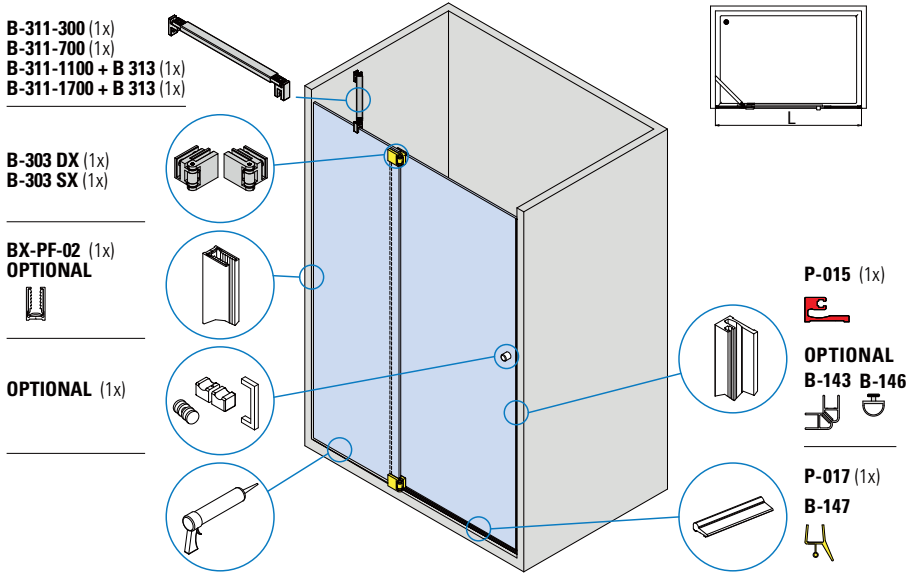
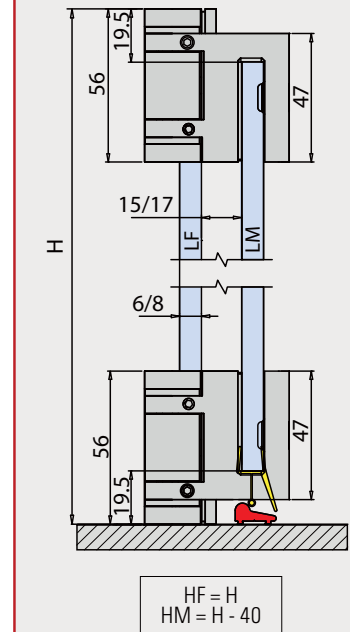
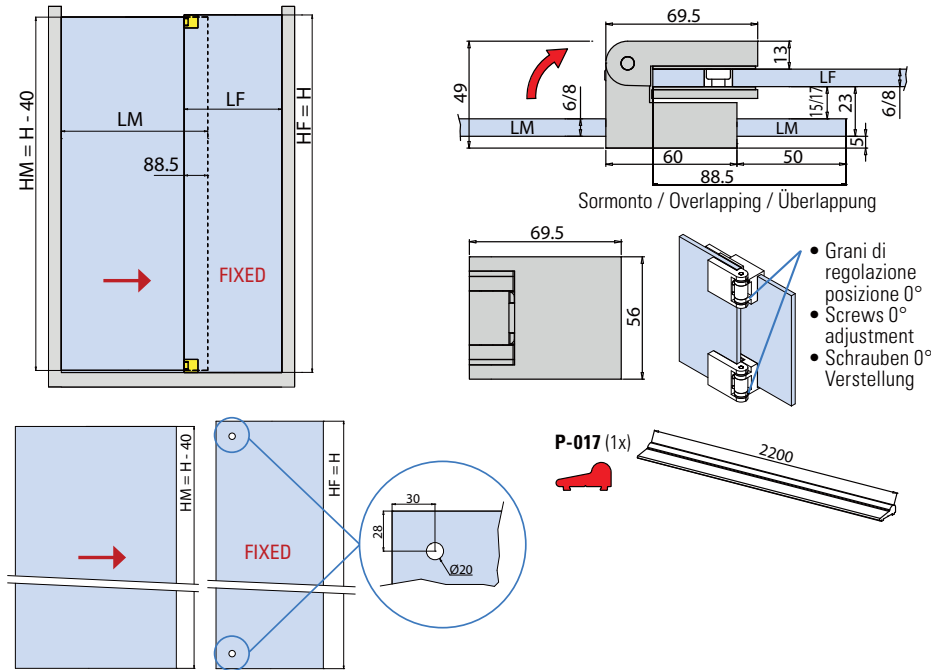
COMPONENTI / COMPONENTS / EINZELTEILE

LAVORAZIONE VETRO / GLASS PREPARATION / GLASBEARBEITUNG

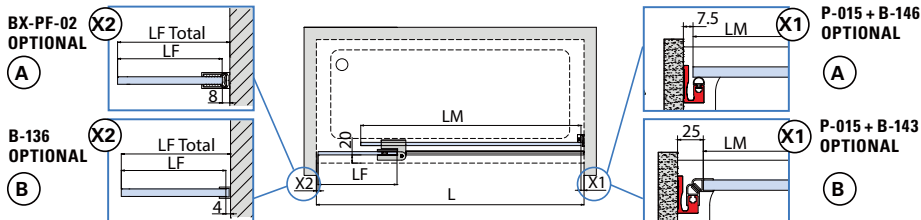
CERNIERE

OPTIONAL

CALCOLO VETRO / CALCULATION GLASS / GLASBERECHNUNG

LF Total = decisione cliente / by customer / Kundenentscheidung
 $LM = (L - LF \text{ Total}) + 88,5$
 $LM = LM - X1 (A / B)$
 $LF = LF \text{ Total} - X2 (A / B)$
 A/B = Variabile in base ai profili optional scelti /
 variable according to the optional profiles / variabel je nach optional Profile

xmc073 / xme232-1

L Piatto Shower tray Duschtaße	LM Larghezza vetro mobile Sliding glass width Schiebeflügel Breite	LF Larghezza vetro fisso Side fixed glass width Seitenteil Breite	HM Altezza vetro mobile Sliding glass height Schiebeflügel Höhe	HF Altezza vetro fisso Side fixed glass height Seitenteil Höhe	H Altezza doccia Shower height Duschkabine Höhe
--	--	---	---	--	---

PROFILI

PROFILES / PROFILE

- PROFILI BATTUTA
- DOOR STOP PROFILES
- TÜRANSCHLAGSPROFILE



P-015 / P-015 -M
P-016 / P-018-M
P-018-B / P-018-V

▶ 162 - 163

- PROFILI GOCCIOLATOIO
- SPLASH GUARD PROFILE
- SCHWALLSCHUTZPROFILE



P-019 / P-017
BX-PT3-C57
BX-PT3-C60

▶ 164

- PROFILI BORDO VETRO
- CLOSURE PROFILE
- VERTIKALE RAHMENPROFILE



BX-DIV-527
BX-DIV-527-M
BX-DIV-502
BX-DIV-526
BX-DIV-543
P-027 / P-027-M

▶ 165 - 167

- PROFILI A TERRA
- FLOOR PROFILES
- BODENPROFILE



BX-PT-C58
BX-PT-C56
BX-PT-C57
BX-PT-C51
BX-PT-C52
BX-PT-C60
BX-PT-C50
BX-3150 / BX-4050
BX-PT2-C50
P-017
BX-PT3-C57
BX-PT3-C60
BX-PT3-C50

▶ 168 - 169

- CANALINE "U"
- U PROFILES
- U-PROFILE



V-2036 / V-2036-T
V-2037 / V-2037-T
V-2038 / V-2038-T
V-2039 / V-2039-T
V-2040 / V-2040-T
V-2041 / V-2041-T
B-138 / B-137 / B-136
BX-PT-C58
BX-PT-C56
BX-PF-01
BX-PF-02

▶ 170 - 171

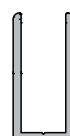

- CANALINE "U" INOX SPIGOLO VIVO
- U PROFILES IN INOX
- U-PROFILE AUS EDELSTAHL



V-2021 / V-2020
V-2016 / V-2017 / V-2019

▶ 172

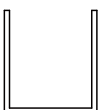

- CANALINE "U" CON BORDO RIPIEGATO
- U PROFILES WITH FOLDED EDGE
- U-PROFILE MIT ABGERUNDETER KANTE



V-2030 / V-2016-R
V-2017-R / V-2029

▶ 172

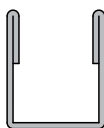

- ANGOLARI
- L PROFILES
- L-PROFILE



V-2025 / V-2024
V-2023 / V-2022

▶ 173



- CANALINE CON ALETTA
- U PROFILES WITH SIDE PLATE
- U-PROFILE MIT PLATTE



V-2028 / V-2027 / V-2026
V-2033 / V-2032 / V-2031

▶ 173

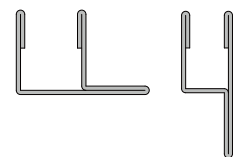

PROFILI

PROFILI BATTUTA DOOR STOP PROFILES / TÜRANSCHLAGSPROFILE

€► BX.249



P-015 / P-015-M

- Profilo battuta a muro per porta battente con possibilità di applicazione guarnizione a palloncino o magnetica. Barre da 2200mm fino a esaurimento scorte. Disponibilità di barre con lunghezza da 2500 mm da verificare con ufficio commerciale.
- Door stop profile for hinged door, available for ball or magnetic gasket. Bars of 2200 mm will be discontinued. Availability of bars with length of 2500 mm to be checked with sales office.
- Türanschlagsprofil lieferbar für pvc und Magnet Dichtung. Profile in 2200 mm Länge lieferbar solange der Vorrat reicht. Die Verfügbarkeit von Profile in 2500 mm Länge ist mit dem Verkaufsbüro abzustimmen.

CR

P-015
B-146
INCLUDED

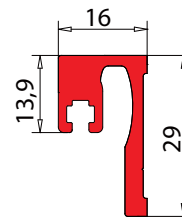
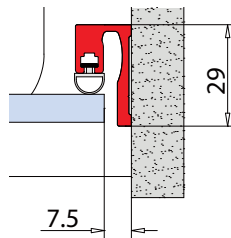

P-015-M
B-143-8
INCLUDED

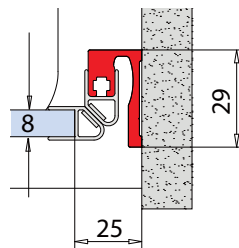

xme203

PROFILI

€► BX.250



P-016

- Profilo bordo vetro per chiusura a battuta con magnete. Barre da 2200mm fino a esaurimento scorte. Disponibilità di barre con lunghezza da 2500 mm da verificare con ufficio commerciale.
- Closure profile for magnetic seal. Bars of 2200 mm will be discontinued. Availability of bars with length of 2500 mm to be checked with sales office.
- Vertikal Rahmenprofil für Magnetische Zuhaltung. Profile in 2200 mm Länge lieferbar solange der Vorrat reicht. Die Verfügbarkeit von Profile in 2500 mm Länge ist mit dem Verkaufsbüro abzustimmen.

CR

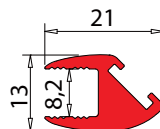

B-148
• Magnete compreso
• Magnetic seal included
• Inkl. Magnetsichtung

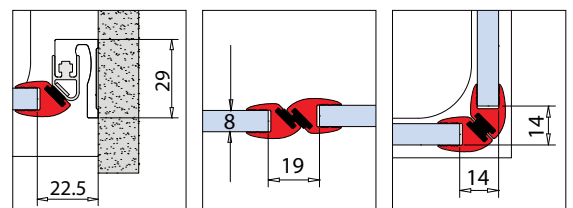

xme203



P-018-M

€ BX.251

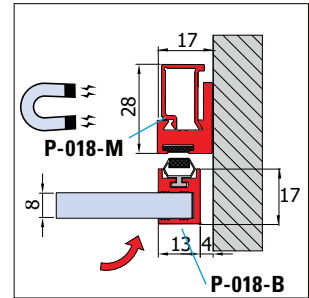
- Profilo battuta a muro per porta battente compreso di magnete.
 - Door stop profile for hinged door, with magnetic gasket.
 - Türanschlagsprofil mit Magnet Dichtung.
- Länge lieferbar solange der Vorrat reicht.
L = 2500 mm
CR - NO

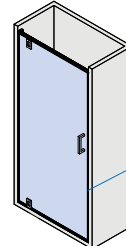
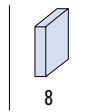

xme305



P-018-B

€ BX.252

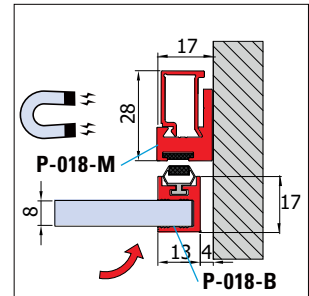
- Profilo bordo vetro con magnete, per chiusura a battuta.
 - Closure profile with magnetic seal for profiles.
 - Vertikal Rahmenprofil für Magnetische Zuhaltung.
- L = 2500 mm
CR - NO

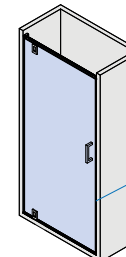
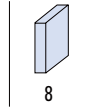

xme305



P-018-V

€ BX.253

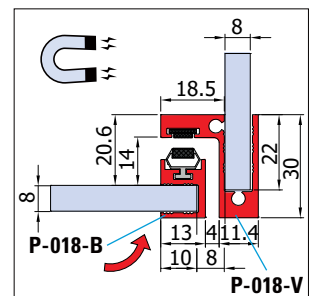
- Profilo battuta a vetro per porta battente compreso di magnete.
 - Door stop profile glass installation for hinged door, with magnetic gasket.
 - Türanschlagsprofil Glasmontage mit Magnet Dichtung.
- L = 2500 mm
CR - NO

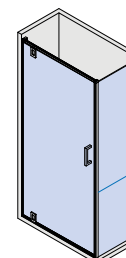
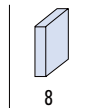

xme305

CR
Cromo lucido
Polished chrome
Chrom glänzend

NO
Nero opaco
Matt black
Schwarz matt

PROFILI

PROFILI GOCCIOLATOIO

SPLASH GUARD PROFILE / SCHWALLSCHUTZPROFILE



P-019

- Profilo gocciolatoio in alluminio cromo lucido. Barre da 2200 mm fino a esaurimento scorte. Disponibilità di barre con lunghezza da 2500 mm da verificare con ufficio commerciale.
 - Splash guard profile. Bars of 2200 mm will be discontinued. Availability of bars with length of 2500 mm to be checked with sales office.
 - Schwallschutz Profil mit PVC Dichtung. Profile in 2200 mm Länge lieferbar solange der Vorrat reicht. Die Verfügbarkeit von Profile in 2500 mm Länge ist mit dem Verkaufsbüro abzustimmen.
- CR - NO

€► BX.254

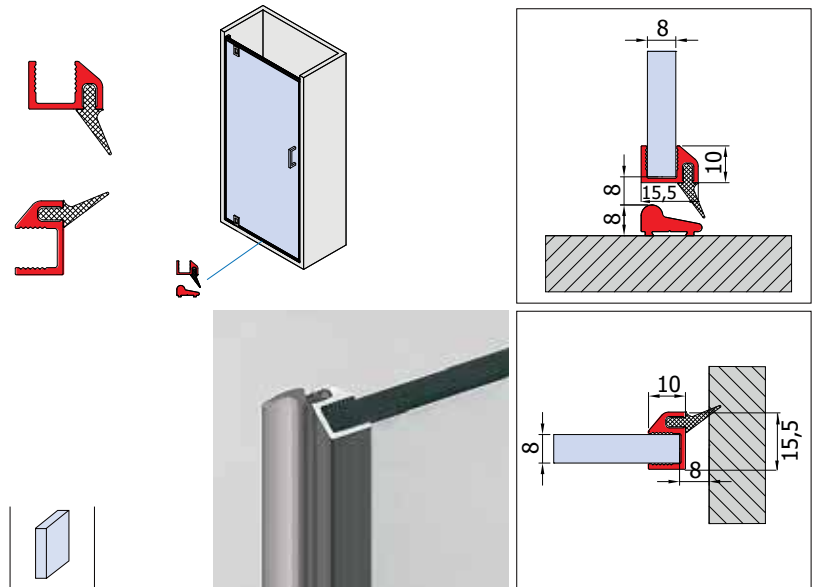

xme305



P-017

- Profilo gocciolatoio.
 - Splash guard profile.
 - Schwallschutz Profil.
- L = 2100 mm
- CR - NO

€► BX.255

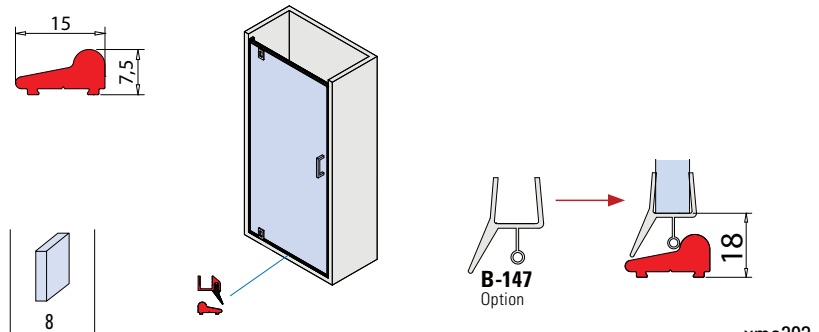

xme203



BX-PT3-C57

€► BX.256

- Angolo 90° lato entrata doccia per profili P-017.
 - Joint 90° corner entry for profiles P-017.
 - 90° Verbindung Eckeinstieg für Profile P-017.
- CR - NO

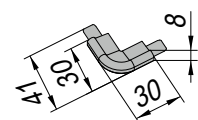

BX-PT3-C60

€► BX.257

- Coperchietto finale per profili P-017, destro e sinistro.
 - Endcap for profiles P-017, left and right.
 - Endkappe für Profile P-017 Links und Rechts.
- CR - NO

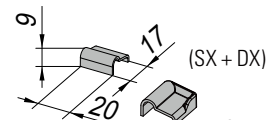

xla367c-2

PROFILI BORDO VETRO

CLOSURE PROFILE / VERTIKALE RAHMENPROFILE



BX-DIV-527

- Profilo bordo vetro con guarnizione a palloncino (componente anta C)
 - Frame profile with balloon gasket (component panel C)
 - Rahmenprofil mit Dichtung (Einzelteil Flügel C)
- L = 3000 mm
CR - NO - IXE - BI - OR

€ BX.258

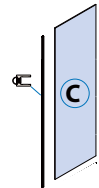
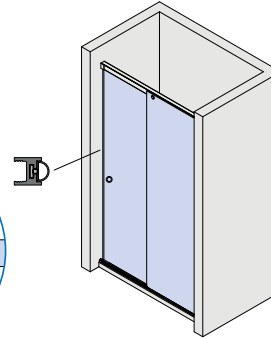
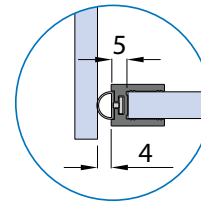
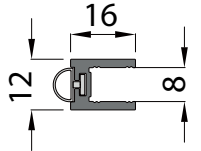

xme632o



BX-DIV-527-M

- Profilo magnetico bordo vetro per chiusura porta battente e vetro fisso.
 - Closure profile for magnetic seal swing door and fixed glass.
 - Vertikal Rahmenprofil für Magnetische zu Haltung Drehtür und Festverglasung.
- L = 3000 mm
CR - NO - IXE - BI - OR

€ BX.259

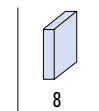
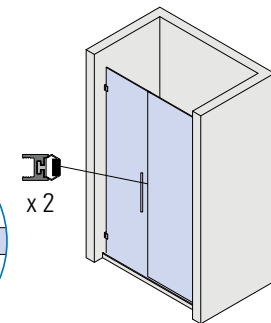
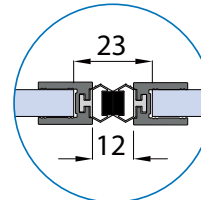
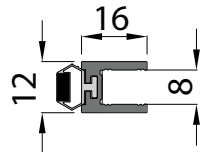

xme632o



BX-DIV-502

- Profilo bordo vetro (componente anta D - E)
 - Frame profile (component panel D - E)
 - Rahmenprofil (Einzelteil Flügel D - E)
- L = 3000 mm / L = 1000 mm
CR - NO - IXE - BI - OR

€ BX.260

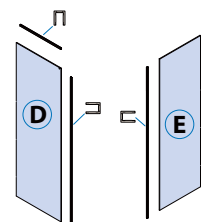
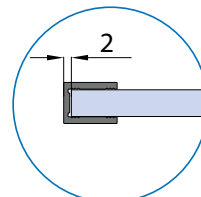
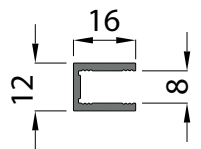

xme632o

CR
Cromo lucido
Polished chrome
Chrom glänzend

NO
Nero opaco
Matt black
Schwarz matt

IXE
Effetto inox satinato
Inox effect
Inox effekt

BI
Bianco opaco
Matt white
Weiss matt

OR
Oro opaco
Matt gold
Gold matt



BX-DIV-526

- Profilo bordo vetro con guarnizione aletta laterale (componente anta A - B - C - E)
- Frame profile, gasket with side fin included (component panel A - B - C - E)
- Rahmenprofil mit Schiebetürdichtprofil (Einzelteil Flügel A - B - C - E)
L = 3000 mm
CR - NO - IXE - BI - OR

€► BX.261

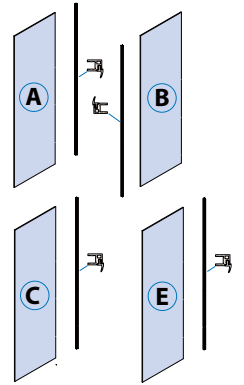
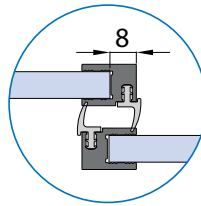
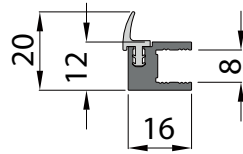

xme632o



BX-DIV-543

- Paio profili bordo vetro con guarnizione magnetica per chiusura 90° (componente anta A)
- Pair frame profiles with 90° magnetic gaskets (component panel A)
- Paar Rahmenprofile mit 90° Magnetsichtungen (Einzelteil Flügel D - E)
L = 3000 mm
CR - NO - IXE - BI - OR

€► BX.262

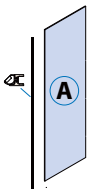
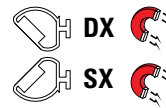
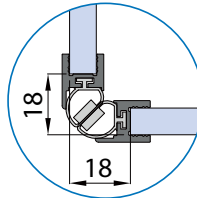
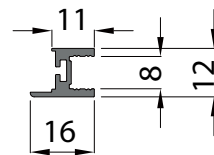

xme632o

PROFILI



P-027

- Profilo bordo vetro con guarnizione a palloncino. Barre da 2200 mm fino a esaurimento scorte. Disponibilità di barre con lunghezza da 2500 mm da verificare con ufficio commerciale.
- Border profile with gasket supplied. Bars of 2200 mm will be discontinued. Availability of bars with length of 2500 mm to be checked with sales office.
- Rahmenprofil mit Dichtung. Profile in 2200 mm Länge lieferbar solange der Vorrat reicht. Die Verfügbarkeit von Profile in 2500 mm Länge ist mit dem Verkaufsbüro abzustimmen.
CR

€► BX.263

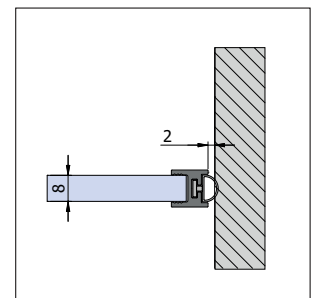
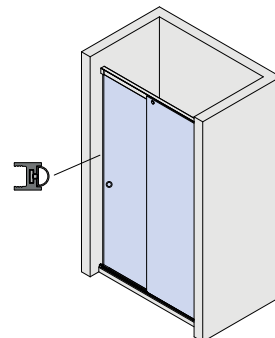
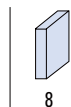
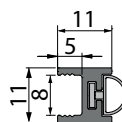

xme446

P-027-M

- Profilo magnetico bordo vetro per chiusura porta battente e vetro fisso. Barre da 2200 mm fino a esaurimento scorte. Disponibilità di barre con lunghezza da 2500 mm da verificare con ufficio commerciale.
- Closure profile for magnetic seal swing door and fixed glass. Bars of 2200 mm will be discontinued. Availability of bars with length of 2500 mm to be checked with sales office.
- Vertikal Rahmenprofil für Magnetische zu Haltung Drehtür und Festverglasung. Profile in 2200 mm Länge lieferbar solange der Vorrat reicht. Die Verfügbarkeit von Profile in 2500 mm Länge ist mit dem Verkaufsbüro abzustimmen.

CR

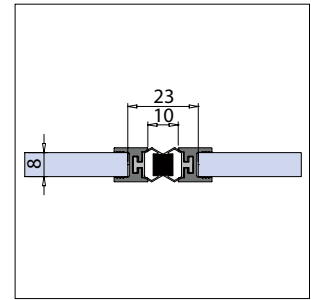
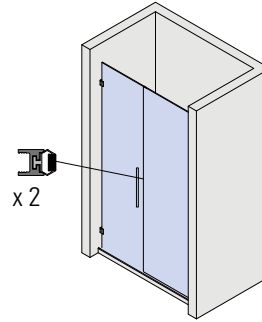
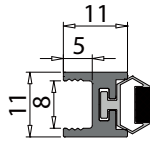

xme446

CR
 Cromo lucido
 Polished chrome
 Chrom glänzend

NO
 Nero opaco
 Matt black
 Schwarz matt

IXE
 Effetto inox satinato
 Inox effect
 Inox effekt

BI
 Bianco opaco
 Matt white
 Weiss matt

OR
 Oro opaco
 Matt gold
 Gold matt

PROFILI

PROFILI A TERRA

FLOOR PROFILES / BODENPROFILE

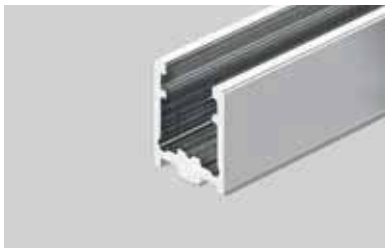

BX-PT-C58

- Profilo per fissaggio a terra o laterale
- Profile for floor and side installation
- Profil Boden- Wandmontage

CR - NO - IXE - BI - OR



Cod.	Fin./Fin./Fin.
BX-PT-C58-1500 mm	CR / NO / IXE / BI / OR
BX-PT-C58-3000 mm	CR / NO / IXE / BI / OR

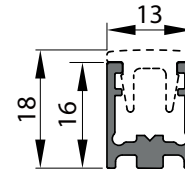

€▶ BX.144

xla367b



BX-PT-C56

- Coperchio per profilo a terra per tratto entrata doccia.
- Cover profile for floor profile, shower entry.
- Profilabdeckung Bodenprofil, Duscheinstieg.

CR - NO - IXE - BI - OR

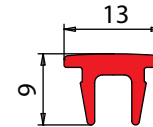

Cod.	Fin./Fin./Fin.
BX-PT-C56-1500 mm	CR / NO / IXE / BI / OR
BX-PT-C56-3000 mm	CR / NO / IXE / BI / OR

€▶ BX.145

xla308



BX-PT-C57

- Angolo 90° lato entrata doccia ad angolo per profili BX-PT-C58 / BX-PT-C56.
- Joint 90° corner entry for profiles BX-PT-C58 / BX-PT-C56.
- 90° Verbindung Eckeinstieg für Profile BX-PT-C58 / BX-PT-C56.

CR - NO - NS - BI - OR

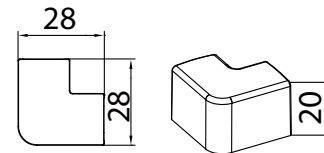

€▶ BX.152

xla306



BX-PT-C51

- Angolo 90° vetro fisso/vetro fisso per profilo BX-PT-C58.
- Joint 90° fixed/fixed glass for profile BX-PT-C58.
- 90° Verbindung 2 Festverglasungen für Profil BX-PT-C58.

CR - NO - NS - BI - OR

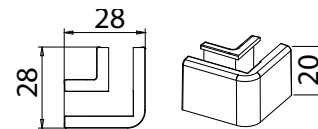

€▶ BX.154

xla308



BX-PT-C52- DX / BX-PT-C52 SX

- Angolo 90° per lato entrata doccia e lato vetro fisso dx e sx per profili BX-PT-C58 / BX-PT-C56.
- Joint 90° entry and fixed glass, left and right for profiles BX-PT-C58 / BX-PT-C56.
- 90° Verbindung Einstieg-Festverglasung, Links und Rechts für Profile BX-PT-C58 / BX-PT-C56.

CR - NO - NS - BI - OR

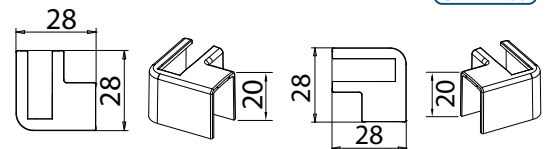

€▶ BX.155

xla308



BX-PT-C60

- Coperchietto finale per profili BX-PT-C58 / BX-PT-C56.
- Endcap for profiles BX-PT-C58 / BX-PT-C56.
- Endkappe für Profile BX-PT-C58 / BX-PT-C56.

CR - NO - NS - BI - OR

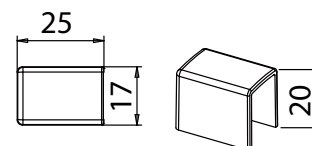

€▶ BX.153

xla307



PROFILI

BX-PT-C50

- Guida vetro scorrevole per applicazione con profilo a terra.
 - Floor guide sliding panel for installation with floor profile.
 - Schiebetür Bodenführung für Montage mit Bodenprofile.
- CR - NO

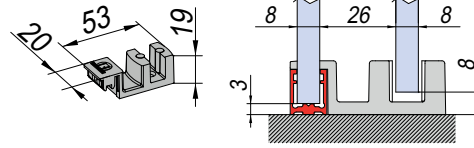

€► BX.150

 HM = H - 8
HF = H - 3

xla367

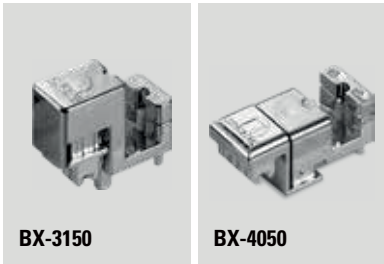

BX-3150

BX-4050

BX-3150 / BX-4050

€► BX.53 €► BX.67

- Guida vetro scorrevole con sistema di sgancio della porta per facilitare la pulizia per applicazione con profilo a terra. BX-PT-C58
- Floor guide sliding panel with quick release door function for easy cleaning for installation with floor profile. BX-PT-C58
- Schiebetür Bodenführung mit auslösbarem System um das Reinigen zu erleichtern für Montage mit Bodenprofile. BX-PT-C58

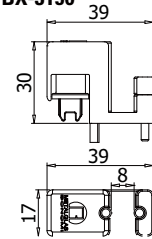
BX-3150

CR - NO - NS - BI - OR

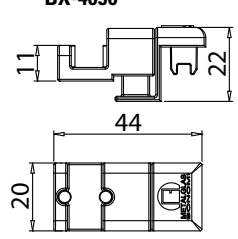
BX-4050

CR - NO - OR

BX-PT2-C50

- Guida vetro scorrevole per applicazione con profilo a terra.
 - Floor guide sliding panel for installation with floor profile.
 - Schiebetür Bodenführung für Montage mit Bodenprofile.
- CR

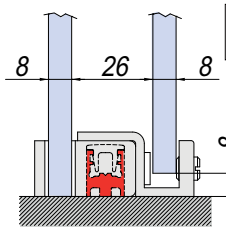
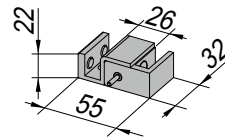

€► BX.156

 HM = H - 8
HF = H

xla367b

P-017

- Profilo gocciolatoio.
 - Splash guard profile.
 - Schwallenschutz Profil.
- L = 2100 mm
CR - NO

Cod.	Fin./Fin./Oberf.
P-017-2100 mm	CR / NO

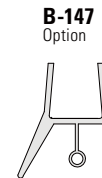
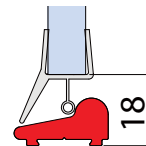
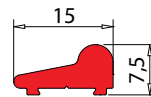
B-147
Option

€► BX.255

xme203



BX-PT3-C57

€► BX.159

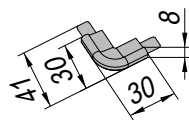
- Angolo 90° lato entrata doccia per profili P-017.
 - Joint 90° corner entry for profiles P-017.
 - 90° Verbindung Eckeinstieg für Profile P-017.
- CR - NO

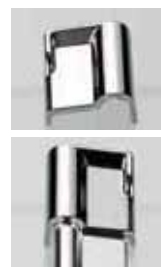

xla367c-2

BX-PT3-C60

€► BX.160

- Coperchietto finale per profili P-017, destro e sinistro.
- Endcap for profiles P-017, left and right.
- Endkappe für Profile P-017 Links und Rechts.

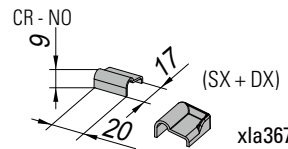

xla367c-2

BX-PT3-C50

- Guida vetro scorrevole per applicazione con profilo a terra P-017.
 - Floor guide sliding panel for installation with floor profile P-017.
 - Schiebetür Bodenführung für Montage mit Bodenprofil P-017.
- CR

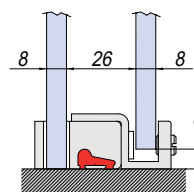
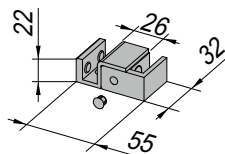

€► BX.157

 HM = H - 8
HF = H

xla367c-2

CR Cromo lucido Polished chrome Chrom glänzend	NO Nero opaco Matt black Schwarz matt	NS Nickel satinato Satin nickel Ähnlich Edelstahl matt	BI Bianco opaco Matt white Weiss matt	OR Oro opaco Matt gold Gold matt
--	---	--	---	--

CANALINE "U"

U PROFILES / U-PROFILE



<p>V-2036 €►BX.272</p> <ul style="list-style-type: none"> • Canalina con bordi arrotondati. • "U" channel. • U-Profil Aluminium. L = 3000 mm CR - IXE - AN <p>V-2036 -T</p> <ul style="list-style-type: none"> • Tappo per profilo • Endcap • EndKappe €►BX.272	<p>V-2037 €►BX.273</p> <ul style="list-style-type: none"> • Canalina con bordi arrotondati. • "U" channel. • U-Profil Aluminium. L = 3000 mm CR - IXE - AN <p>V-2037 -T</p> <ul style="list-style-type: none"> • Tappo per profilo • Endcap • EndKappe €►BX.273	<p>V-2038 €►BX.274</p> <ul style="list-style-type: none"> • Canalina con bordi arrotondati. • "U" channel. • U-Profil Aluminium. L = 3000 mm CR - IXE - AN <p>V-2038 -T</p> <ul style="list-style-type: none"> • Tappo per profilo • Endcap • EndKappe €►BX.274	<p>V-2039 €►BX.275</p> <ul style="list-style-type: none"> • Canalina con bordi arrotondati. • "U" channel. • U-Profil Aluminium. L = 3000 mm CR - IXE - AN <p>V-2039 -T</p> <ul style="list-style-type: none"> • Tappo per profilo • Endcap • EndKappe €►BX.275	<p>V-2040 €►BX.276</p> <ul style="list-style-type: none"> • Canalina con bordi arrotondati. • "U" channel. • U-Profil Aluminium. L = 3000 mm CR - IXE - AN <p>V-2040 -T</p> <ul style="list-style-type: none"> • Tappo per profilo • Endcap • EndKappe €►BX.276	<p>V-2041 €►BX.277</p> <ul style="list-style-type: none"> • Canalina con bordi arrotondati. • "U" channel. • U-Profil Aluminium. L = 3000 mm CR - IXE - AN <p>V-2041 -T</p> <ul style="list-style-type: none"> • Tappo per profilo • Endcap • EndKappe €►BX.277
---	---	---	---	---	---

B-138 €► BX.271

- Canalina spigoli vivi.
 - Sharp corner "U" channel.
 - U-Profil Aluminium.
- L = 3000 mm
CR - AN

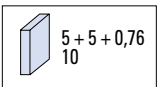
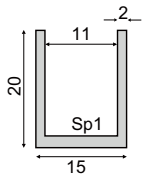
B-137 €► BX.270

- Canalina spigoli vivi.
 - Sharp corner "U" channel.
 - U-Profil Aluminium.
- L = 3000 mm
CR - AN

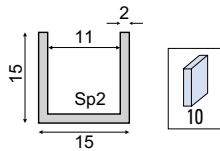
B-136 €► BX.268

- Canalina con bordi arrotondati.
 - "U" channel.
 - "U"-Profil Aluminium.
- L = 3000 mm
CR - NO

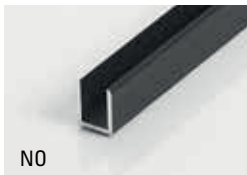
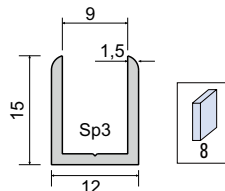
BX-PT-C58 €► BX.265
€► BX.266

- Canalina con bordi arrotondati.
 - "U" channel.
 - "U"-Profil Aluminium.
- L = 1500 / 3000 mm
CR - NO - IXE - BI - OR

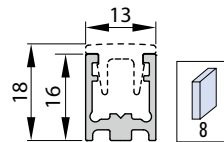
BX-PT-C56 €► BX.267

- Coperchio per profilo a terra BX-PT-C58 per tratto entrata doccia.
 - Cover profile for floor profile BX-PT-C58, shower entry.
 - Profilabdeckung Bodenprofil BX-PT-C58, Duscheinstieg.
- L = 1500 / 3000 mm
CR - NO - IXE - BI - OR

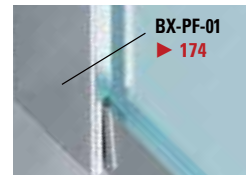
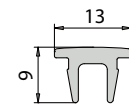

CR
Cromo lucido
Polished chrome
Chrom glänzend

AN
Alluminio anodizzato
Aluminium anodized
Aluminium Silberfarbig

NO
Nero opaco
Matt black
Schwarz matt

IXE
Effetto inox
Inox effect
Inox effekt

BI
Bianco opaco
Matt white
Weiss matt

OR
Oro opaco
Matt gold
Gold matt

xla367b

xla308

CANALINE "U"

CANALINE "U" CON BORDO A SPIGOLO VIVO L = 2500 mm U PROFILES / U-PROFILE

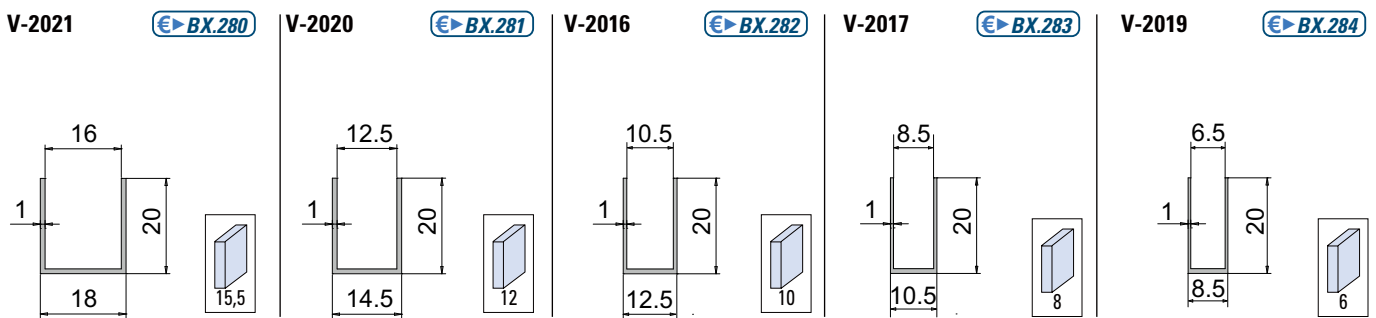
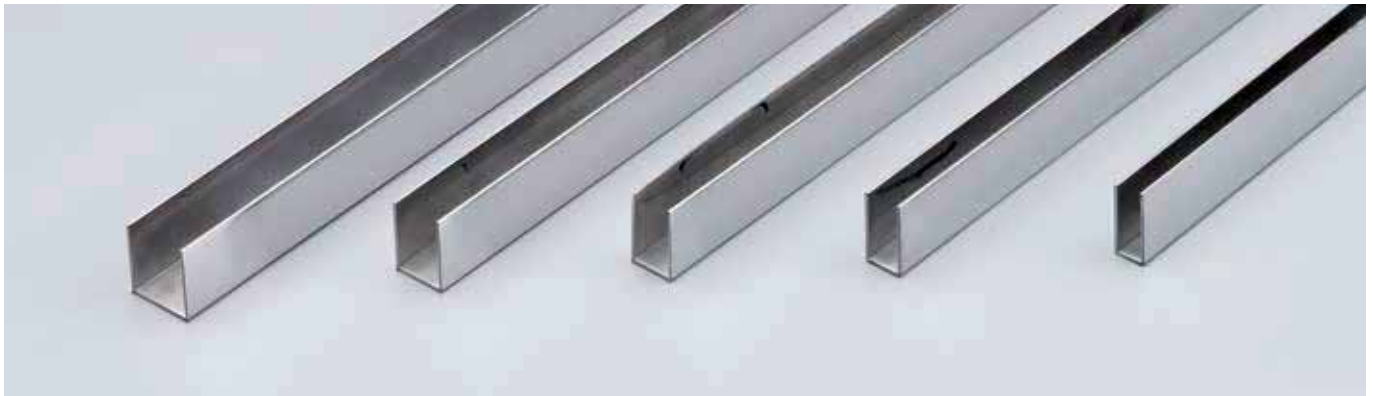

IX IL
Materiale / Material / Material
Inox AISI 304

CANALINE "U" CON BORDO RIPIEGATO L = 2500 mm U PROFILES WITH FOLDED EDGE / U-PROFILE MIT ABGERUNDETER KANTE

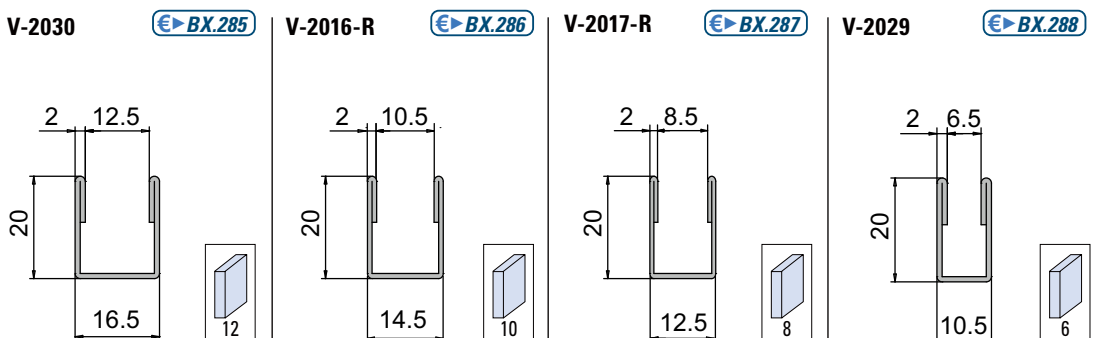

IX IL
Materiale / Material / Material
Inox AISI 304

CANALINE "U"

ANGOLARI L = 2500 mm

L PROFILES / L-PROFILE

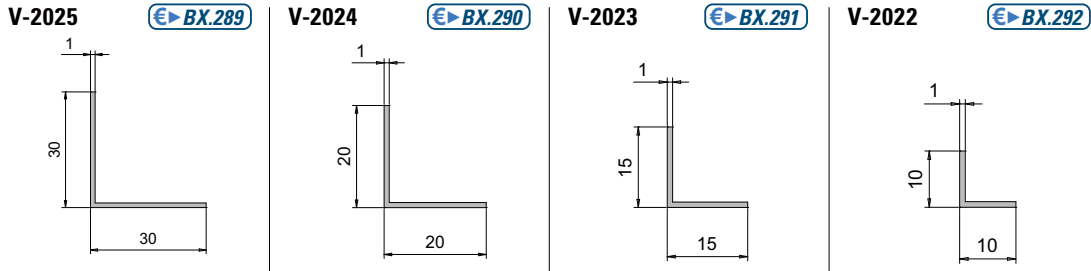

IX IL
 Materiale / Material / Material
 Inox AISI 304

CANALINE CON ALETTA LATERALE L = 2500 mm

U PROFILES WITH SIDE PLATE / U-PROFILE MIT SEITLICHER PLATTE

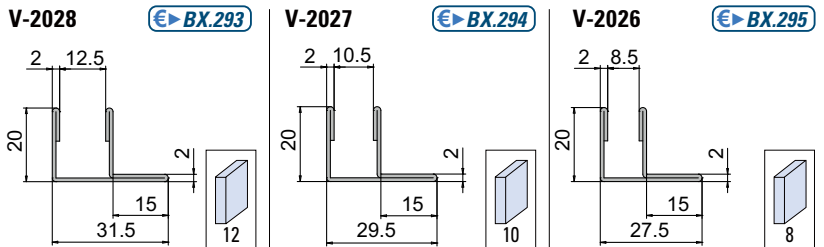

IX IL
 Materiale / Material / Material
 Inox AISI 304

CANALINE CON ALETTA L = 2500 mm

U PROFILES WITH PLATE / U-PROFILE MIT PLATTE

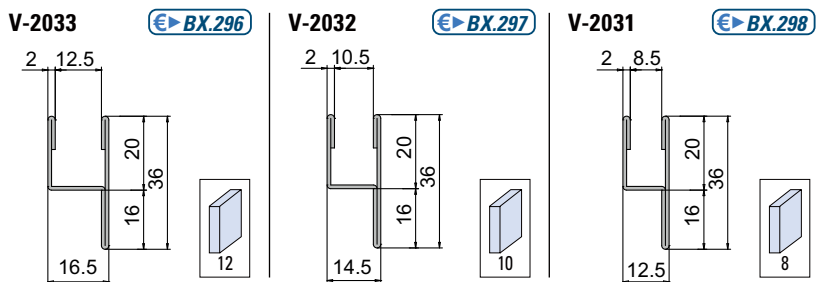

IX IL
 Materiale / Material / Material
 Inox AISI 304

CANALINE "U"

PROFILO PER FISSO A MURO CON GUARNIZIONE PROFILE WITH GASKET FOR FIXED SIDE PANEL / PROFIL FÜR SEITLICHE FESTVERGLASUNG MIT DICHTUNG

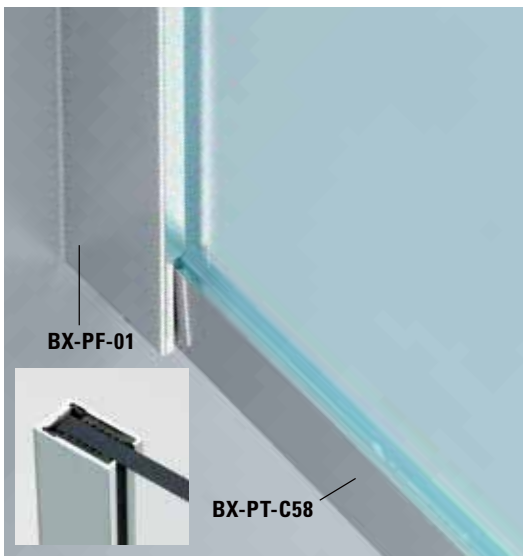

BX-PF-01

€▶ BX.278

- Profilo per fisso a muro con fresatura per accoppiamento con profili a terra BX-PT-01. Barre da 2200 mm fino a esaurimento scorte. Disponibilità di barre con lunghezza da 2500 mm da verificare con ufficio commerciale.
- Profile for fixed side panel with milling for coupling with floor profiles BX-PT-01. Bars of 2200 mm will be discontinued. Availability of bars with length of 2500 mm to be checked with sales office.
- Profil für seitliche Festverglasung mit fräsung für Verbindung mit Bodenprofile BX-PT-01. Profile in 2200 mm Länge lieferbar solange der Vorrat reicht. Die Verfügbarkeit von Profile in 2500 mm Länge ist mit dem Verkaufsbüro abzustimmen.

CR - NO

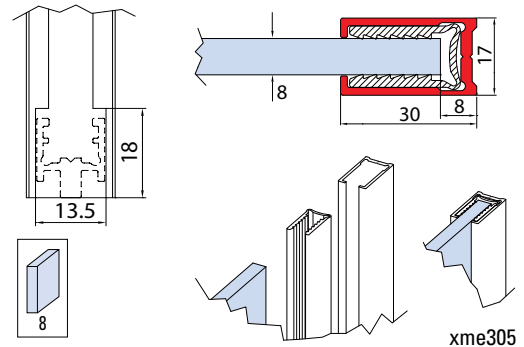

BX-PF-02

€▶ BX.279

- Profilo per fisso a muro. Barre da 2200 mm fino a esaurimento scorte. Disponibilità di barre con lunghezza da 2500 mm da verificare con ufficio commerciale.
- Profile for fixed side panel. Bars of 2200 mm will be discontinued. Availability of bars with length of 2500 mm to be checked with sales office.
- Profil für seitliche Festverglasung. Profile in 2200 mm Länge lieferbar solange der Vorrat reicht. Die Verfügbarkeit von Profile in 2500 mm Länge ist mit dem Verkaufsbüro abzustimmen.

CR - NO

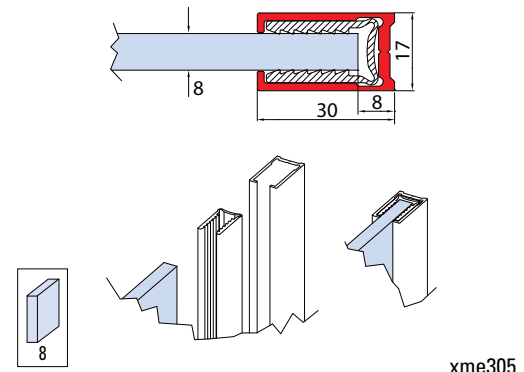

CANALINE "U"

CR
Cromo lucido
Polished chrome
Chrom glänzend

NO
Nero opaco
Matt black
Schwarz matt



CANALINE "U"



BOX DOCCIA SEPARÉ

SHOWERS AREA SEPARÉ
 DUSCHTRENNWAND SEPARÉ



SEPARÉ

► 178



- BARRE DI SUPPORTO QUADRE REGOLABILI
- ADJUSTABLE SQUARE SUPPORT BARS
- VERSTELLBARE ECKIGE STABILISATIONSSTANGEN

► 180



- BARRE DI SUPPORTO QUADRE
- SQUARE SUPPORT BARS
- ECKIGE STABILISATIONSSTANGEN

► 184



- BARRE DI SUPPORTO TONDE
- ROUND SUPPORT BARS
- RUNDE STABILISATIONSSTANGEN

► 185



SEPARÉ

SEPARÉ

BOX DOCCIA SEPARÉ / SHOWERS AREA SEPARÉ / DUSCHTRENNWAND SEPARÉ

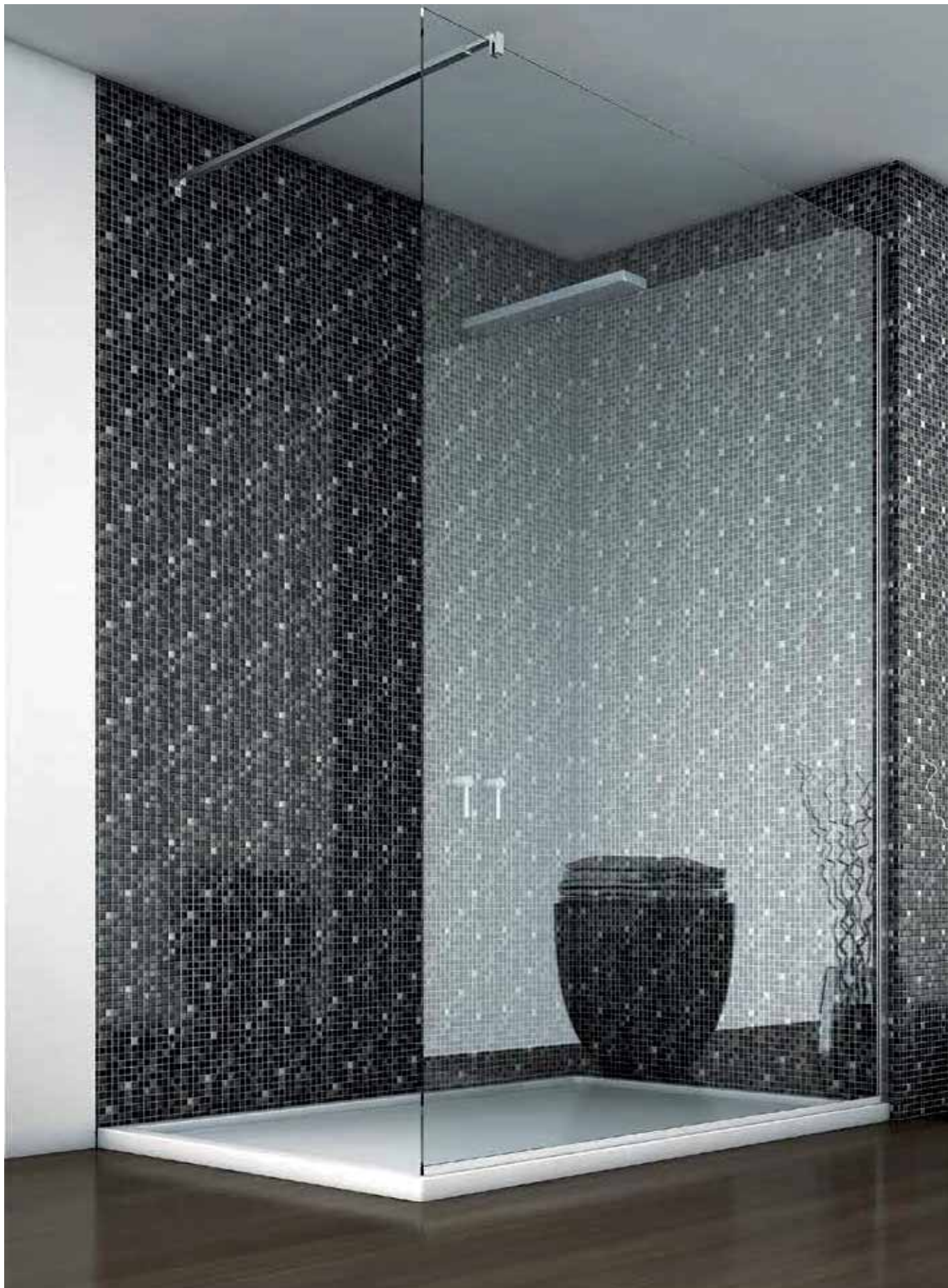

SEPARÉ

- Sistema per docce aperte tutto vetro senza porte.
- Walk-in systems for open shower areas without doors.
- Walk-in Systeme für offene Duschen ohne Türen.



- Alcune tipologie di applicazione
- Some application typologies
- Einigen kompositionsmöglichkeiten des system

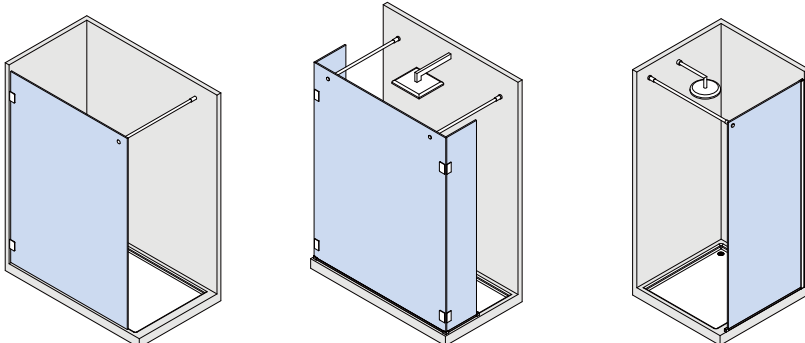

BARRE DI SUPPORTO QUADRE SNODATE SQUARE SQUARE SUPPORT BARS / ECKIGE STABILISATIONSTANGEN



B-328

- Barra di supporto snodata Square riducibile a piacere muro/vetro.
- Square adjustable support bar wall/glass, it is possible to cut the bar to adjust its size.
- Eckige Stabilisationsstange Wand/Glas, beliebig Kürzbar.

€ BX.302

ART.	Lunghezza (A) Length (A) Länge (A)	Finitura Finish Oberflächen
B-328-500	500 mm	CR NS NO
B-328-1000	1000 mm	CR NS NO OR
B-328-1500	1500 mm	IL NO OR

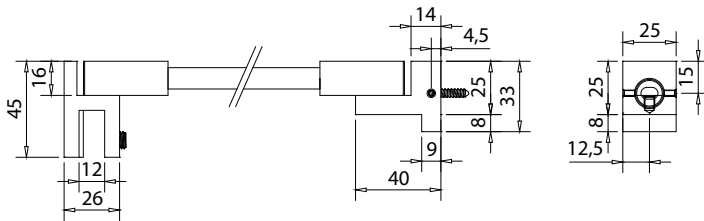

B-328-F

- Barra di supporto snodata a muro con attacco fisso a vetro B-324.
- Square support bar with adjustable wall connector and fixed glass connector B-324.
- Eckige Stabilisationsstange Wandanschluss vestellbar, Glasanschluss fest B-324.

€ BX.303

ART.	Lunghezza (A) Length (A) Länge (A)	Finitura Finish Oberflächen
B-328-F-500	500 mm	CR NS NO
B-328-F-1000	1000 mm	CR NS NO
B-328-F-1500	1500 mm	IL NO

C-272-A

COMPONENTI / COMPONENTS / EINZELTEILE



B-318

- Barra centrale Square riducibile a piacere.
- Square centre bar possible to cut to adjust its size.
- Eckige Stange beliebig Kürzbar.

€ BX.304

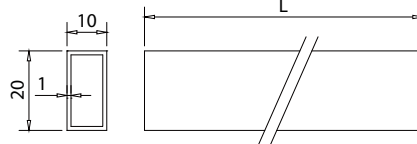

ART.	Lunghezza (A) Length (A) Länge (A)	Finitura Finish Oberflächen
B-318-500	500 mm	CR NS NO
B-318-1000	1000 mm	CR NS NO OR
B-318-1500	1500 mm	IL NO OR

CR
Cromo lucido
Polished chrome
Chrom glänzend

NS
Nickel satinato
Satin nickel
Ähnlich Edelstahl matt

IL
Acciaio inox lucido
Polished stainless steel
Edelstahl poliert

NO
Nero opaco
Matt black
Schwarz matt

OR
Oro opaco
Matt gold
Gold matt

B-320

- Attacco a vetro snodato per barra di supporto quadra.
 - Adjustable glass connector for square support bar.
 - Eckige Stabilisationsstange Glasanschluss verstellbar.
- CR - NS - NO - OR

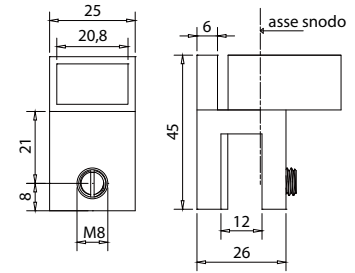

C-272-C

B-319

- Attacco a muro snodato per barra di supporto quadra.
 - Adjustable wall connector for square support bar.
 - Eckige Stabilisationsstange Wandanschluss verstellbar.
- CR - NS - NO - OR

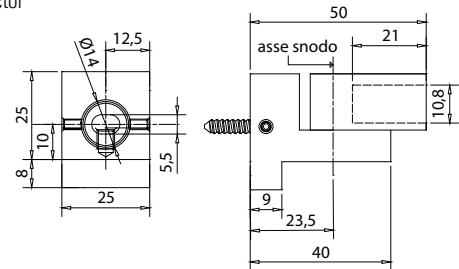

C-272-B

B-324

- Attacco a vetro chiuso.
 - Glass connector for square support bar.
 - Eckige Stabilisationsstange Glasanschluss.
- CR - NS - NO

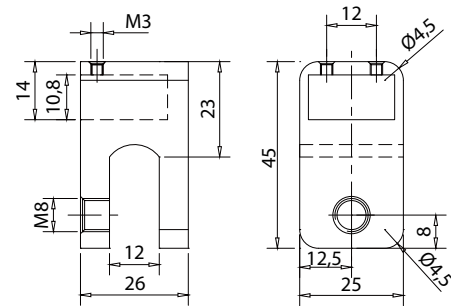

C-272-D

B-325

- Supporto centrale snodato per vetro fisso laterale.
 - Adjustable T-connector side glass to support bar.
 - Verstellbares T-Stück für Glas/Stange.
- CR - NS - NO - OR

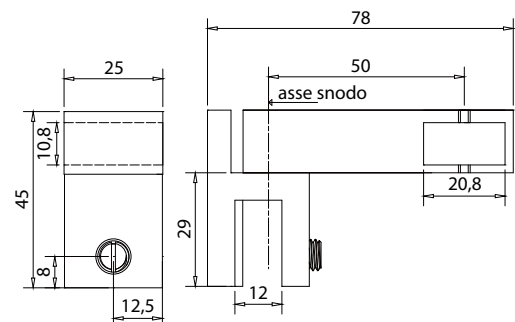

C-272-F

CR
 Cromo lucido
 Polished chrome
 Chrom glänzend

NS
 Nickel satinato
 Satin nickel
 Ähnlich Edelstahl matt



B-322

- Attacco a vetro in linea passante.
 - Glass connector in-line for passage support bar.
 - Glasanschluss in Linie für Stabilisationsstange durchgehend.
- CR - NS

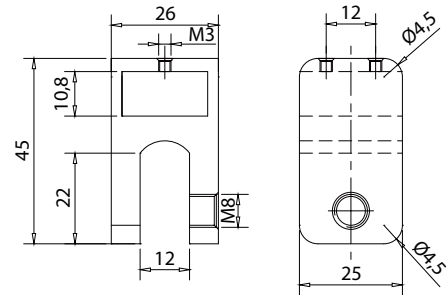

€► BX.308

C-272-E



B-323

- Attacco a vetro chiuso per barra di supporto quadra.
 - Glass connector for square support bar.
 - Eckige Stabilisationsstange Glasanschluss.
- CR - NS

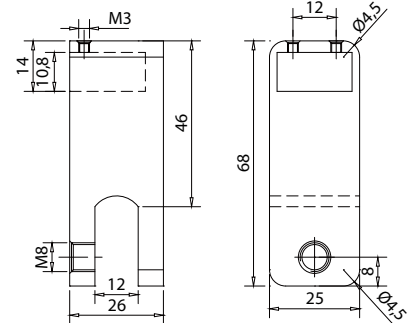

€► BX.309

C-272-D



B-321

- Attacco a vetro 90° passante.
 - Glass connector 90° for passage support bar.
 - Glasanschluss 90° für Stabilisationsstange durchgehend.
- CR - NS

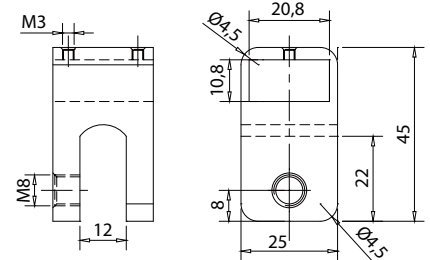

€► BX.307

C-272-D



B-326

- Attacco snodato montaggio a vetro.
 - Adjustable connector for glass installation.
 - Verstellbarer Anschluss für Glasmontage.
- CR - NS

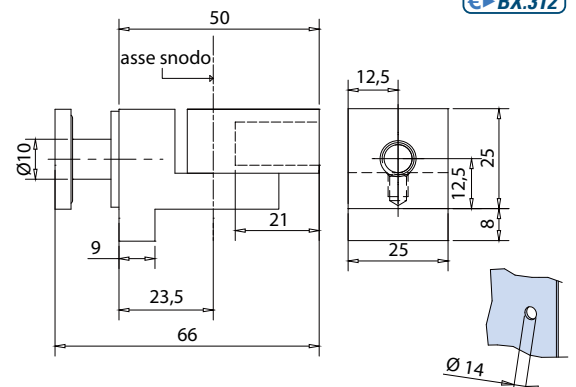

€► BX.312

C-272-G

SEPARÉ

CR
Cromo lucido
Polished chrome
Chrom glänzend
182

NS
Nickel satinato
Satin nickel
Ähnlich Edelstahl matt

NO
Nero opaco
Matt black
Schwarz matt

OR
Oro opaco
Matt gold
Gold matt

B-327

- Attacco snodato doppio.
 - 2-Ways adjustable connector.
 - Verstellbarer Anschluss 2-Wege
- CR - NS

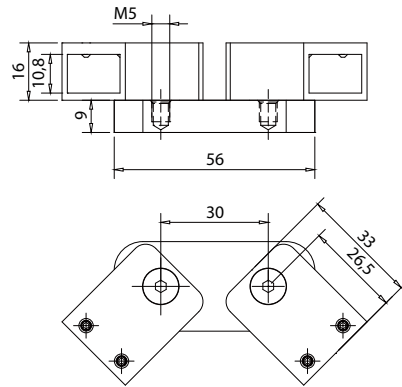

C-272-H



SEPARÉ

BARRE DI SUPPORTO QUADRE SQUARE SUPPORT BARS / ECKIGE STABILISATIONSSTANGEN

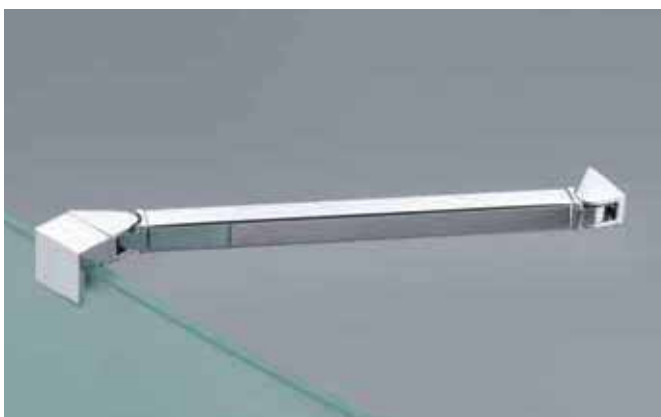

B-511-220 / B-511-370

- Barra di supporto quadra angolare snodata vetro/muro.
- Square support bar wall/glass.
- Eckige Stabilisationsstange Wand/Glas.

CR - NS

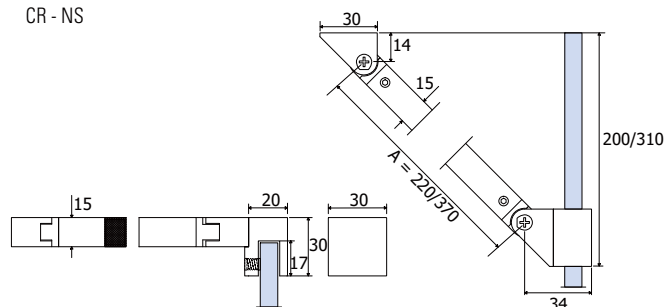

€► BX.314

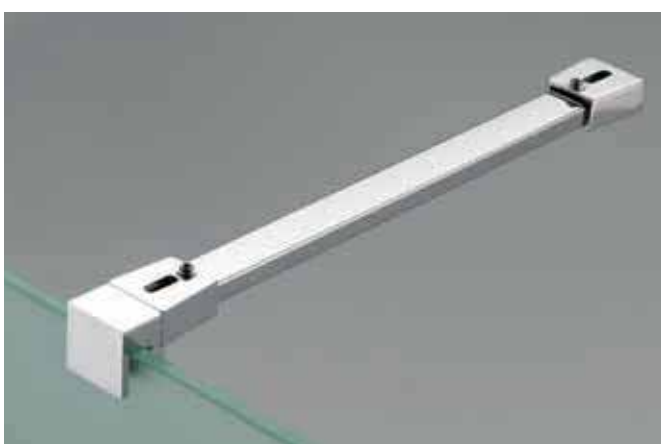

B-521

- Barra di supporto quadra a 90° vetro/muro.
- Square support bar wall/glass 90°.
- Eckige Stabilisationsstange Wand/Glas 90°.

CR - NS

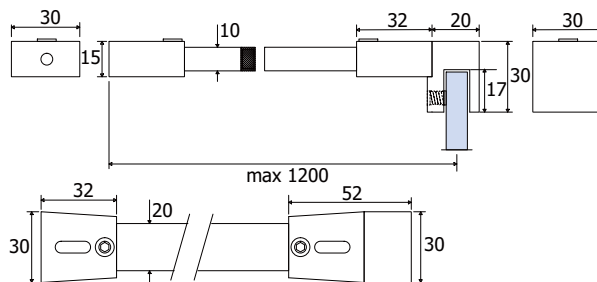

€► BX.316

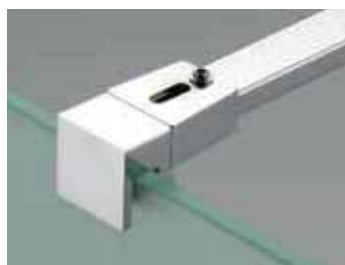

B-529 €► BX.317

- Barra centrale quadra per B-527, B-528 L=1200 mm.
- Square support bar for B-527, B-528 L=1200 mm.
- Eckige Stabilisationsstange für B-527, B-528 L=1200 mm.

CR - NS

B-528 €► BX.318

- Attacco a muro per barra di supporto quadra B-529.
- Wall fitting for B-529 support bar.
- B-529 Stabilisationsstange Wandanschluss.

CR - NS

B-527 €► BX.319

- Attacco a vetro per la barra quadra B-529.
- Glass fitting for support bar B-529.
- Glasanschluss für Stabilisationsstange B-529 zu können.

CR - NS

B-523 €► BX.320

- Supporto centrale per vetro fisso laterale con barra B-521 / B-529.
- Middle connector glass fitting/Square bar support B-521 / B-529.
- Mittelverbinder Glasanschluss/Square Stabilisationsstange B-521 / B-529.

CR

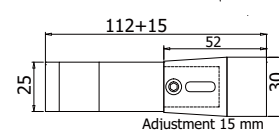
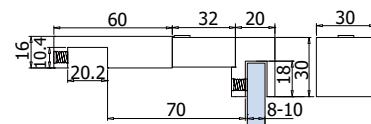
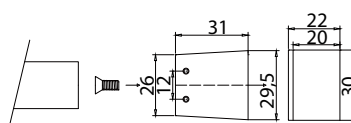
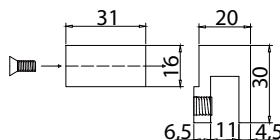
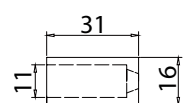
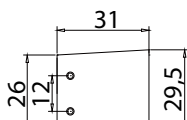
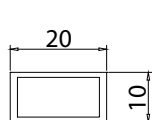

SEPARÉ

xme397

xme396

xmc023

CR
Cromo lucido
Polished chrome
Chrom glänzend
184

NS
Nickel satinato
Satin nickel
Ähnlich Edelstahl matt

BARRE DI SUPPORTO TONDE

ROUND SUPPORT BARS / RUNDE STABILISATIONSSTANGEN



B-189

- Barra di fissaggio vetro/soffitto.
 - Glass to ceiling fixing bar.
 - Stabilisationsstange Glas-Decke.
- CR

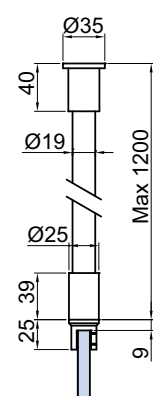
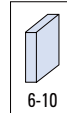

€ BX.339

xfb-086



B-185-S

- Attacco verticale a vetro per tubo Ø 19.
 - Vertical glass clamp for Ø 19 mm tube.
 - Vertikal Rohrverbinder / Glas für Rohr Ø 19 mm.
- CR

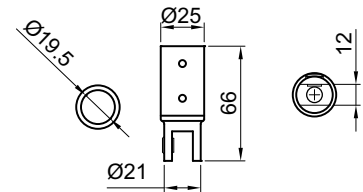

€ BX.338

xfb-089



SEPARÉ

BARRE DI SUPPORTO TONDE ROUND SUPPORT BARS / RUNDE STABILISATIONSTANGEN



- B-171** €►BX.324
- Barra di fissaggio vetro/muro.
 - Glass to wall fixing bar.
 - Stabilisationsstange Glas/Wand.
- CR - NS

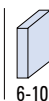
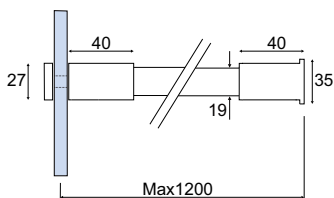
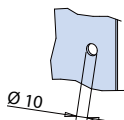

- B-160** €►BX.321
- Barra di fissaggio vetro/muro 45°.
 - Glass to wall 45° fixing bar.
 - Stabilisationsstange Glas-Wand 45°.
- CR - NS

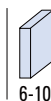
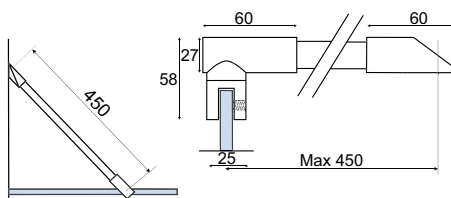

- B-174** €►BX.327
- Terminale a muro per barre fermavetro Ø 19 mm.
 - Wall fixing bar end for Ø 19 mm tube.
 - Drehbar Halterungen für Stabilisationsstange.
- CR - NS

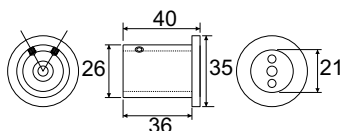

- B-185** €►BX.328
- Attacco a vetro per tubo Ø 19 mm.
 - Ottone forgiato.
 - Glass clamp for 19 mm tube. Forged brass.
 - Rohrverbinder / Glas für Rohr Ø 19 mm.
 - Messing geschmiedet.
- CR - NS

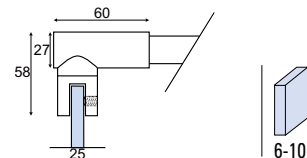

- B-175 (L=1200 mm)** €►BX.325
B-176 (L=2000 mm) €►BX.326
- Tubo inox lucido Ø 19 mm.
 - Polished stainless steel tube Ø 19 mm.
 - Halterungen für Stabilisationsstange.
- CR - NS

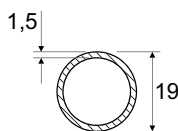

- B-181** €►BX.337
- Raccordo vetro-barra a 90°.
 - Connector Glass-bar 90°.
 - Verbinder Glas/Rohr 90°.
- CR - NS

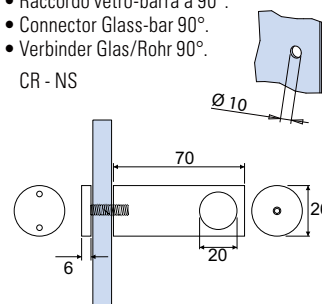

- B-172** €►BX.329
- Raccordo di congiunzione a 90° per tubo Ø 19 mm.
 - Forged brass 90° connection joint for 19 mm tube.
 - Stabilisationsstange T-Stück für 19 mm Rohr.
- CR - NS

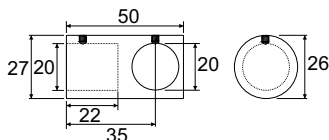

- B-163** €►BX.332
- Attacco a vetro foro passante per tubo Ø 19 mm.
 - Glass clamp for 19 mm tube.
 - Rohrverbinder/Glas für Rohr Ø 19 mm.
- CR - NS

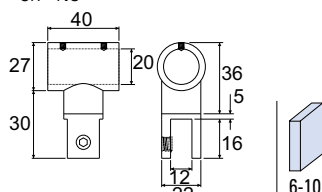

SEPARÉ



B-161 €► **BX.322**
 • Barra di fissaggio vetro/muro 90°.
 • Glass to wall 90° fixing bar.
 • Stabilisationsstange Glas-Wand.
 CR - NS

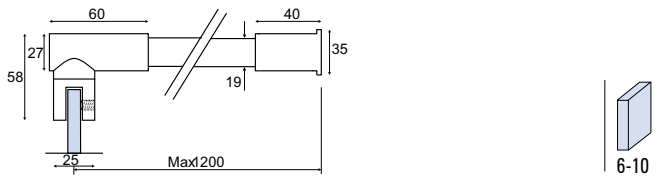

B-162 €► **BX.323**
 • Barra di fissaggio vetro/vetro.
 • Glass to glass fixing bar.
 • Stabilisationsstange Glas-Glas.
 CR - NS

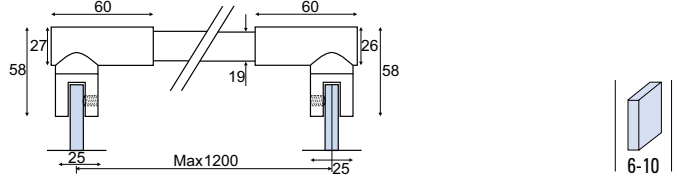

B-167 €► **BX.331**
 • Fermavetro snodata a muro.
 • Ends Forged brass.
 • Halterungen für Stabilisationsstange.
 CR - NS

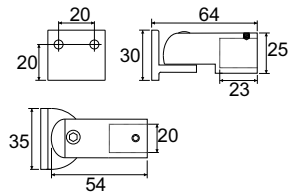

B-166 €► **BX.330**
 • Terminali per barra.
 • Articulated glass to wall bar.
 • Drehbar Messing geschmiedet.
 CR - NS

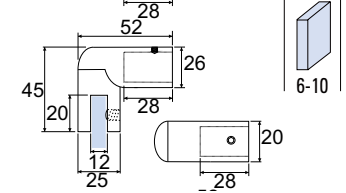

B-164 €► **BX.333**
 • Raccordo a 135° per tubo Ø19 mm.
 • 135° connector for 19 mm tube Forged brass.
 • Rohrverbinder 135° für Rohr Ø 19 mm.
 CR - NS

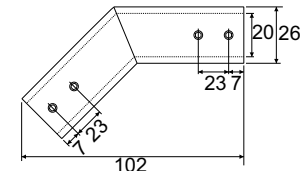

B-165 €► **BX.334**
 • Raccordo a 90° per tubo Ø19 mm.
 • 90° connector for 19 mm tube.
 • Rohrverbinder 90° für Rohr Ø 19 mm.
 CR - NS

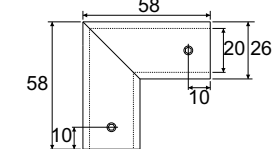

B-184 €► **BX.335**
 • Terminale a muro 45° per barre fermavetro Ø 19 mm.
 • Wall fixing bar 45° end for Ø 19 mm tube.
 • Drehbar Halterungen 45° für Stabilisationsstange.
 CR - NS

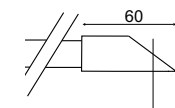

B-173 €► **BX.336**
 • Raccordo regolabile per tubo Ø 19 mm.
 • Adjustable connector for Ø 19 mm tube.
 • Verbinder für 19 mm Rohr Verstellbar.
 CR - NS

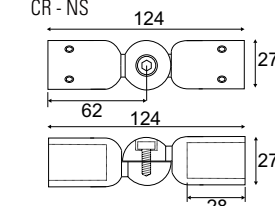

CR
 Cromo lucido
 Polished chrome
 Chrom glänzend

NS
 Nickel satinato
 Satin nickel
 Ähnlich Edelstahl matt

SEPARÉ

ACCESSORI

ACCESSORIES / ZUBEHÖRE

- MORSETTI
- CLAMPS
- KLEMMBESCHLÄGE



B-155/40 / B-154/40 / B-156/40 / B-152/40 / B-153/40
B-157/40 / B-158/40 / B-182 / B-183 / B-187 / B-188
B-159-50 / B-160-50

► 190 - 193

- RAGNETTI
- CONNECTORS
- WINKELVERBINDER



B-20 / B-25 / B-21 / B-30 / B-35 / B-16 / B-17

► 194 - 195

- GUARNIZIONI MINI
- MINI GASKETS
- MINI DICHTUNGEN

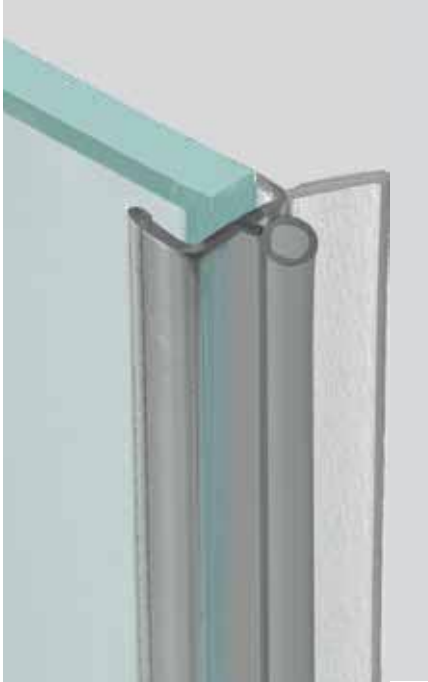

B-115-20 / B-115-25 / B-142-8
B-144-8 / B-116-8 / B-117-8
B-118-8 / B-119-8

► 196 - 197

- GUARNIZIONI
- GASKETS
- DICHTUNGEN



B-151-26 / B-151-20 / B-141-8
B-141-10 / B-143-8 / B-143-10
B-145-8 / B-145-10 / B-147-8
B-147-10 / B-149-8 / B-149-10
B-152-MIX / B-153-MIX / B-154-MIX
B-155-MIX
WRU-C-BUMP-MT12 / WRU-M 80/50

► 198 - 201

- POMOLI, NICCHIE, MANIGLIONI
- KNOBS, SLIDING HANDLES, HANDLES
- KNÖPFE, GRIFFMUSCHEL, STOSSGRIFFE



B-196 / B-198 / V-024 25 / V-024 30
V-024 38 / B-168 / B-169 / V-1107
B-197 / B-177 / B-178 / B-194 / B-195
B-192 / V-019 / V-1056 / V-1056-2
V-1105 / B-191-80 / B-191-240
B-193 / V-526 / V-524 / B-170 / V-528
DIV-008 / DIV-007

SQUARE 10-INC / POR-0408 V
POR-0400 V / ROUND MINI 16
SQUARE MINI 15 / SQUARE 10
SQUARE 15 / SQ01/SQ02
B-120 / B-121 / B-122 / B-186
B-124 / B-125

PG-CHIAVE

► 202 - 213

MORSETTI CLAMPS / KLEMMBESCHLÄGE



B-155-40

- Morsetto 40x40 mm vetro/muro. Materiale: Ottone.
- Glass to wall clamp 40x40 mm. Material: Brass.
- Verbinders Glas-Wand, 40x40 mm mit nicht sichtbaren Schrauben. Material: Messing.

CR - NS

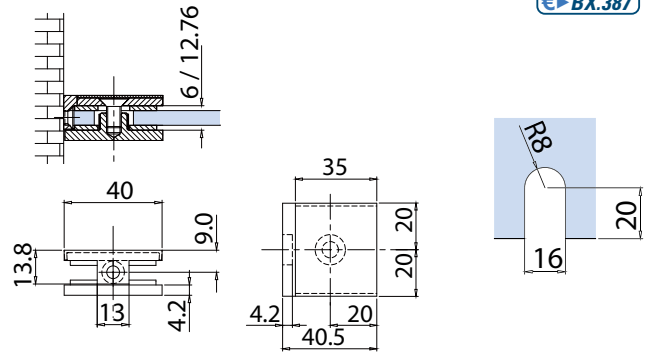

€ BX.387

xme312



B-154-40

- Morsetto 40x40 mm vetro/muro. Materiale: Ottone.
- Glass to wall clamp 40x40 mm. Material: Brass.
- Verbinders Glas-Wand, 40x40 mm mit nicht sichtbaren Schrauben. Material: Messing.

CR - NS

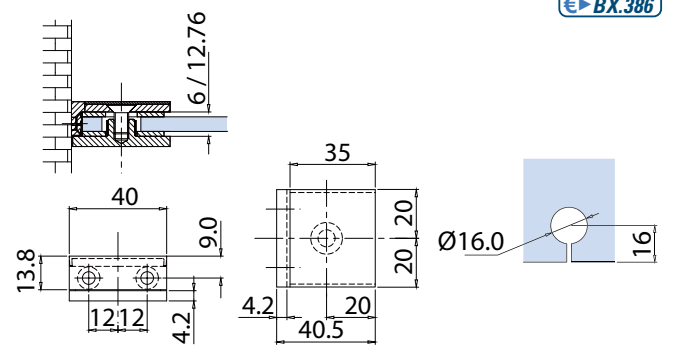

€ BX.386

xme312



B-156-40

- Morsetto angolare 90° 40x40 mm vetro/muro. Materiale: Ottone.
- Glass to wall angular clamp 90° 40x40 mm. Material: Brass.
- Winkelverbinder Glas-Wand 90°, 40x40 mm mit nicht sichtbaren Schrauben. Material: Messing.

CR - NS

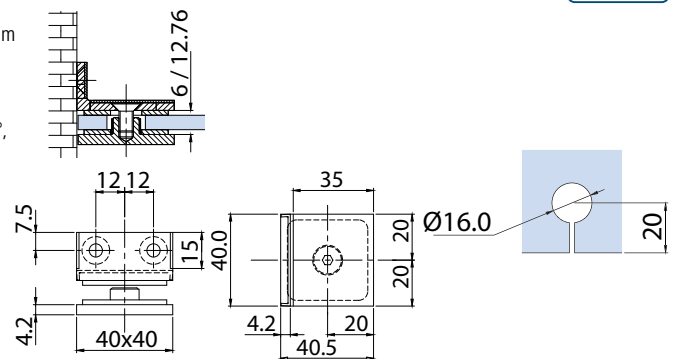

€ BX.388

xme313



B-152-40

- Morsetto angolare 40x40 mm vetro/muro 90°. Materiale: Ottone.
- Glass to wall 90° angular clamp 40x40 mm. Material: Brass.
- Winkelverbinder Glas-Wand 90°, 40x40 mm mit nicht sichtbaren Schrauben. Material: Messing.

CR - NS - NO

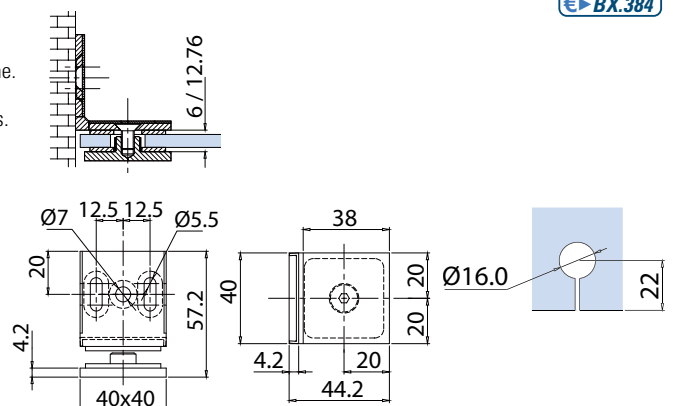

€ BX.384

xme312

B-153-40

- Morsetto angolare 40x40 mm vetro/vetro 90°. Materiale: Ottone.
 - Glass to glass 90° angular clamp 40x40 mm. Material: Brass.
 - Winkelverbinder Glas-Glas 90°, 40x40 mm mit nicht sichtbaren Schrauben. Material: Messing.
- CR - NS - NO

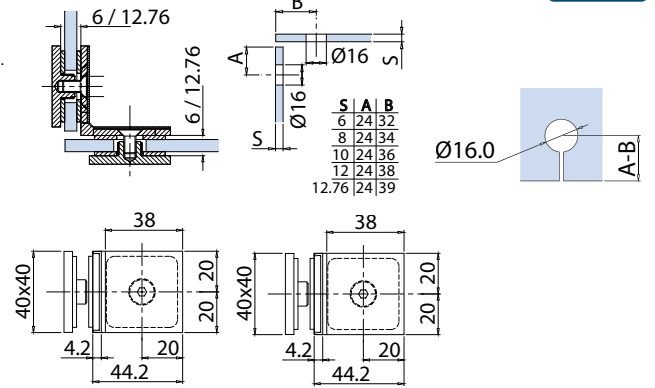

xme312

B-157-40

- Morsetto 40x40 mm vetro/muro 180°. Materiale: Ottone.
 - Glass to wall clamp 180° 40x40 mm. Material: Brass.
 - Verbinder Glas-Wand 180°, 40x40 mm mit nicht sichtbaren Schrauben. Material: Messing.
- CR - NS - NO

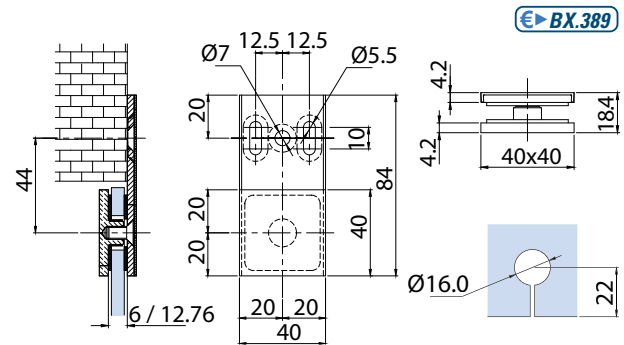

xme313

B-158-40

- Morsetto 40x40 mm vetro/vetro 180°. Materiale: Ottone.
 - Glass to glass clamp 180°, 40x40 mm. Material: Brass.
 - Verbinder Glas-Glas 180°, 40x40 mm mit nicht sichtbaren Schrauben. Material: Messing.
- CR - NS

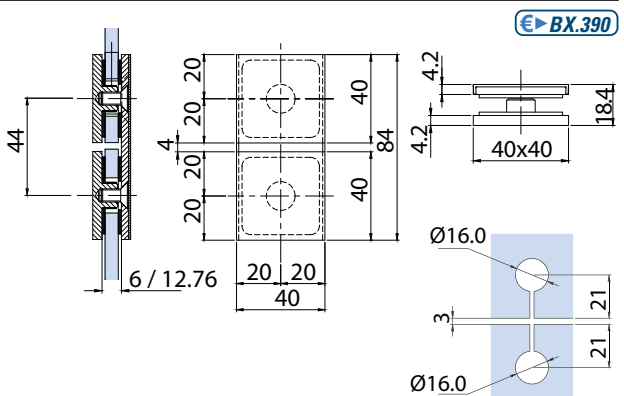

xme313

B-182

- Morsetto angolare 56x40 mm vetro/muro 90°. Materiale: Ottone.
 - Glass to wall 90° angular clamp 56x40 mm. Material: Brass.
 - Winkelverbinder Glas-Wand 90°, 56x40 mm mit nicht sichtbaren Schrauben. Material: Messing.
- CR - NS

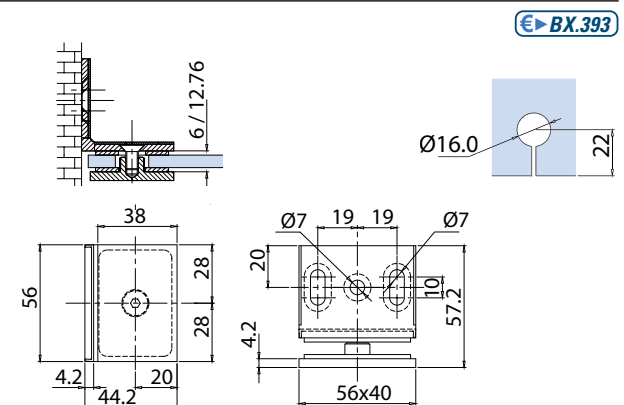

xme314

CR
Cromo lucido
Polished chrome
Chrom glänzend

NS
Nickel satinato
Satin nickel
Ähnlich Edelstahl matt

NO
Nero opaco
Matt black
Schwarz matt



B-183

- Morsetto angolare 56x40 mm vetro/vetro 90°. Materiale: Ottone.
- Glass to glass 90° angular clamp 56x40 mm. Material: Brass.
- Winkelverbinder Glas-Glas 90°, 56x40 mm mit nicht sichtbaren Schrauben. Material: Messing. CR - NS

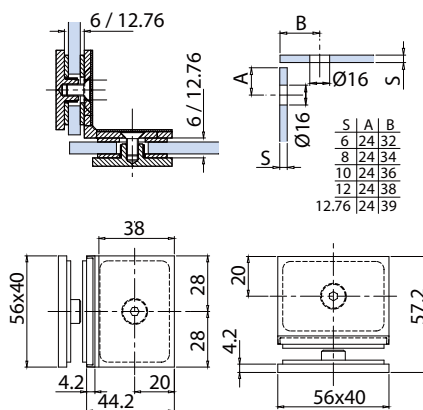

€ BX.394

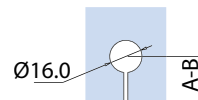

xme314



B-187

- Morsetto 56x40 mm vetro/muro 180°. Materiale: Ottone.
- Glass to wall clamp 180°, 56x40 mm. Material: Brass.
- Verbinder Glas-Wand 180°, 56x40 mm mit nicht sichtbaren Schrauben. Material: Messing. CR - NS

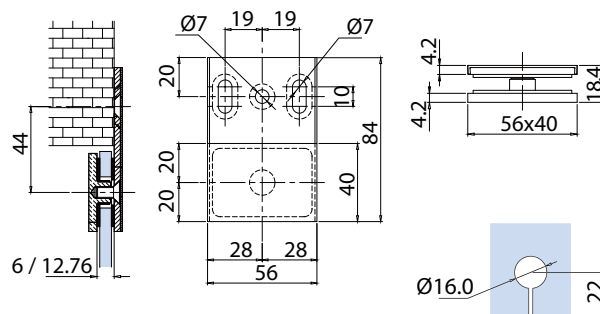

€ BX.395

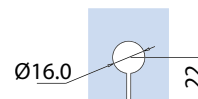

xme314



B-188

- Morsetto 56x40 mm vetro/vetro 180°. Materiale: Ottone.
- Glass to glass clamp 180°, 56x40 mm. Material: Brass.
- Verbinder Glas-Glas 180°, 56x40 mm mit nicht sichtbaren Schrauben. Material: Messing. CR - NS

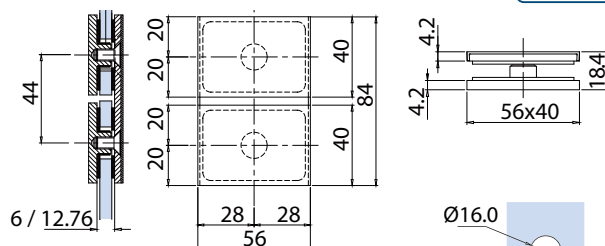

€ BX.396

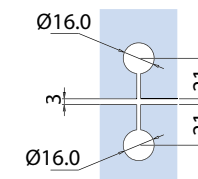

xme314



B-159-50

- Morsetto angolare 50x50 mm vetro/muro senza viti in vista.
- Glass to wall 90° angular clamp 50x50 mm with not visible screws.
- Winkelverbinder Glas-Wand 90° 50x50 mm mit nicht sichtbaren Schrauben. CR

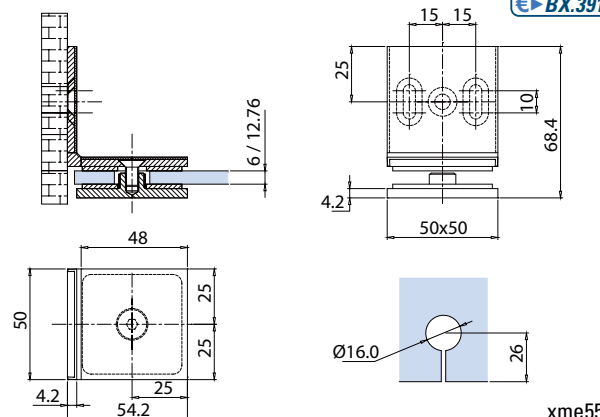

€ BX.391

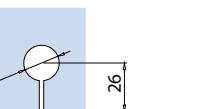

xme553

CR
Cromo lucido
Polished chrome
Chrom glänzend
192

NS
Nickel satinato
Satin nickel
Ähnlich Edelstahl matt

B-160-50

- Morsetto angolare 50x50 mm vetro/vetro 90°. Senza viti a vista.
- Glass to glass 90° angular clamp 50x50 mm. With not visible screws.
- Winkelverbinder Glas-Glas 90°, 50x50 mm mit nicht sichtbaren Schrauben. Ohne sichtbare Schrauben.

CR - NS

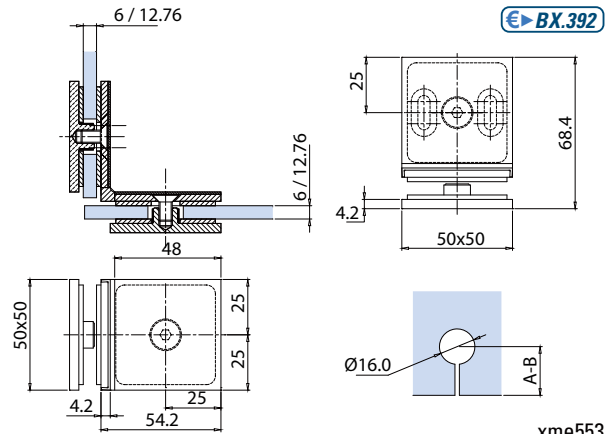
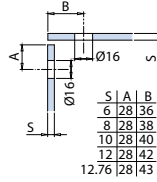

xme553



RAGNETTI

CONNECTOR / WINKELVERBINDER



B-20

- Ragnetto muro/vetro.
Materiale: Inox.
- Connector glass/wall.
Material: Stainless.
- Winkelverbinder Glas/Wand.
Material: Edelstahl.
IX - IL

€► BX.401

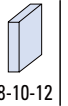
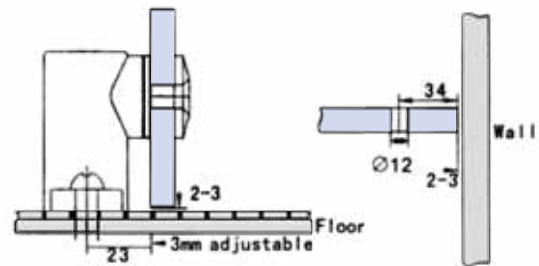

B-25

- Barra di connessione 2 vetri.
Materiale: Inox.
- Connecting rod for 2 glass.
Material: Stainless.
- Verbinder 2 Gläser.
Material: Edelstahl.
IX - IL

€► BX.403

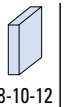
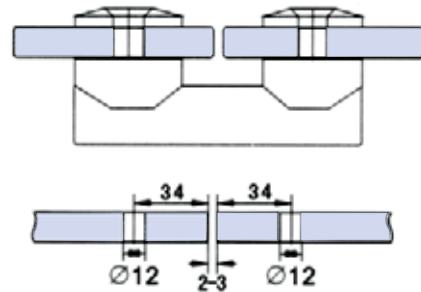

B-21

- Ragnetto vetro/vetro.
Materiale: Inox.
- Connector glass/glass.
Material: Stainless.
- Winkelverbinder Glas/Glas.
Material: Edelstahl.
IX - IL

€► BX.402

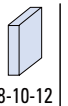
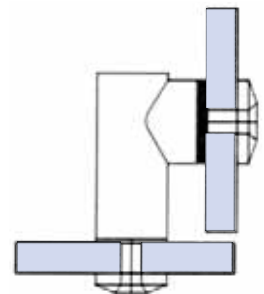

B-30

- Ragnetto muro/vetro.
Materiale: Inox.
- Connector glass/wall.
Material: Stainless.
- Winkelverbinder Glas/Wand.
Material: Edelstahl.
IX - IL

€► BX.404

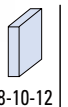
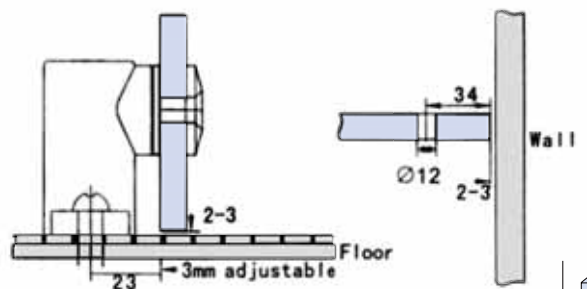

B-35

- Barra di connessione 2 vetri.
Materiale: Inox.
- Connecting rod for 2 glass.
Material: Stainless.
- Verbinder 2 Gläser.
Material: Edelstahl.
IX - IL

€► BX.405

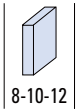
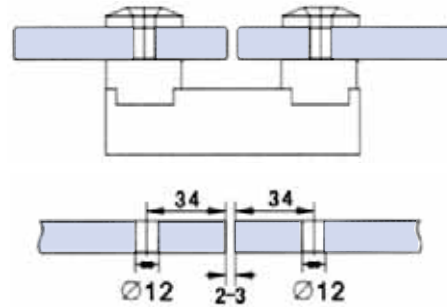
B-16

- Fermaporta con attacco a terra e calamita.
Materiale: Inox.
- Magnetic door hold and stopper wall/glass.
Material: Stainless.
- Magnetische Türstopper Wand/Glas.
Material: Edelstahl.
IX - IL

€► BX.399

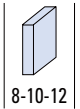
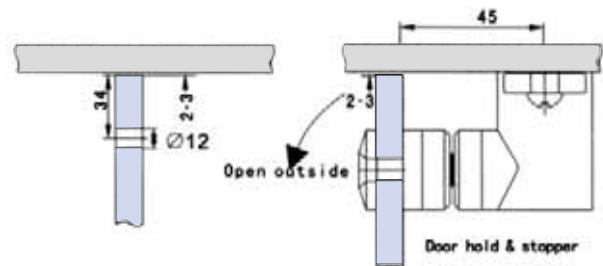

B-17

- Fermaporta con attacco a vetro e calamita.
Materiale: Inox.
- Magnetic door hold and stopper glass/glass.
Material: Stainless.
- Magnetische Türstopper Glas/Glas.
Material: Edelstahl.
IX - IL

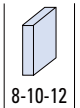
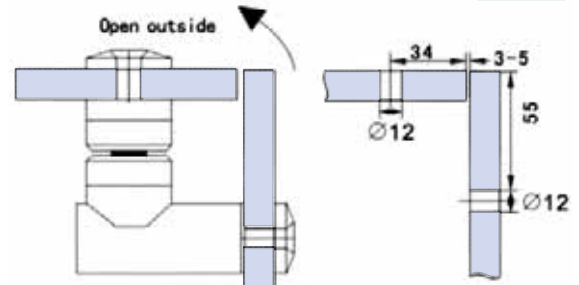
€► BX.400

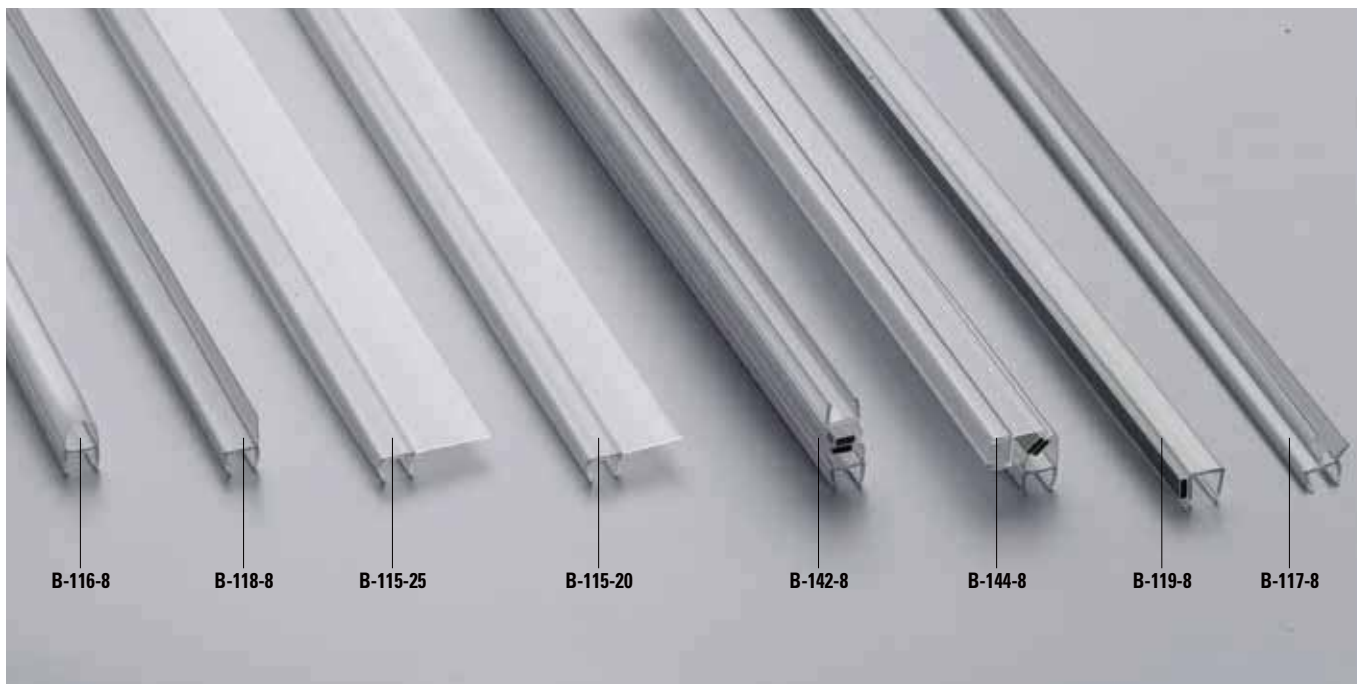

GUARNIZIONI MINI MINI GASKETS / MINI DICHTUNGEN



B-115-20

- Guarnizione per scorrevoli in PVC trasparente.
- Sliding doors seal in transparent PVC.
- PVC Dichtprofil für Schiebetüren.



L=2500

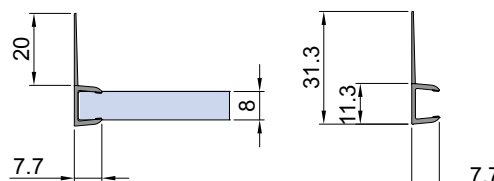

€ BX.410

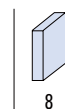

8
xfb-095



B-115-25

- Guarnizione per scorrevoli in PVC trasparente.
- Sliding doors seal in transparent PVC.
- PVC Dichtprofil für Schiebetüren.



L=2500

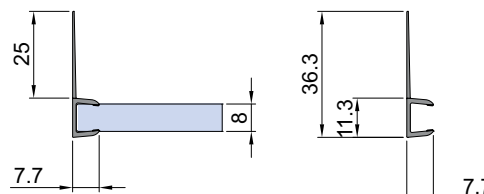

€ BX.409

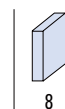

8
xfb-095



B-142-8

- Guarnizione magnetica in PVC trasparente per chiusura a 180°.
- PVC magnetic seal for 180° closing doors in transparent PVC twin bars.
- PVC Magnetdichtung für Glas-Glas 180° Paar Profile.



L=2500

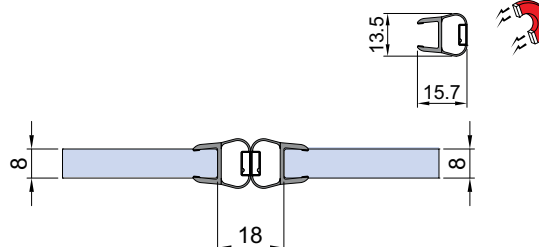

€ BX.411

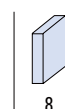

8
xfb-093

B-144-8

- Guarnizione magnetica in PVC trasparente per chiusure a 90°.
- PVC magnetic seal for 90° closing doors in transparent PVC
- Magnetdichtung für Glas-Glas 90°.

L=2500

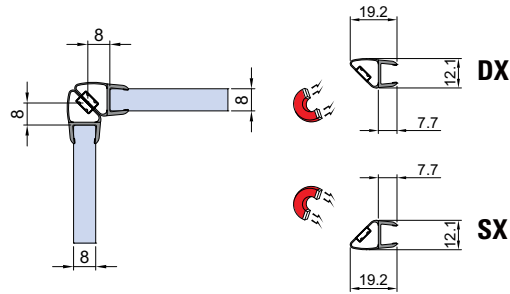
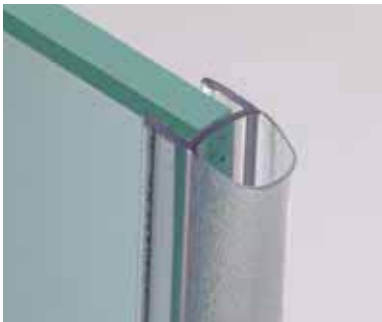
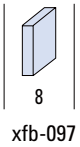
BX.412

B-116-8

- Guarnizione a palloncino vetro/muro in PVC trasparente.
- Glass to wall ball seal transparent PVC.
- PVC Dichtprofil Glas-Wand.

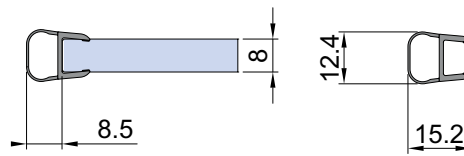
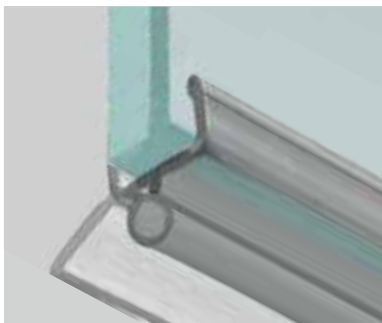
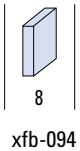
L=2500

BX.407

B-117-8

- Guarnizione gocciolatoio in PVC trasparente.
- Drip flap seal transparent PVC.
- PVC Dichtprofil für den unteren Wannenanschluss.

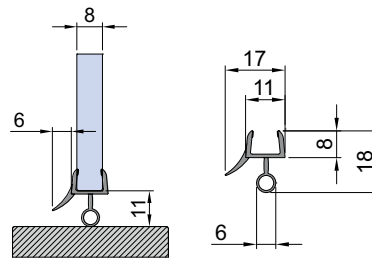
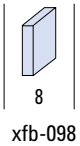
L=2500

BX.414

B-118-8

- Guarnizione vetro/vetro in PVC trasparente per chiusure a 180°.
- Door stop seal transparent PVC for glass-glass 180°.
- PVC Dichtprofil für Glas-Glas 180°.

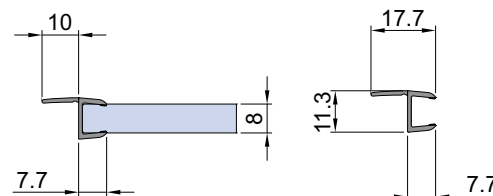
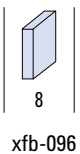
L=2500

BX.408

B-119-8

- Guarnizione bordo vetro con magneti, per chiusura a battuta.
- Closure gasket with magnetic seal.
- Vertikal Dichtung für Magnetische Zuhaltung.

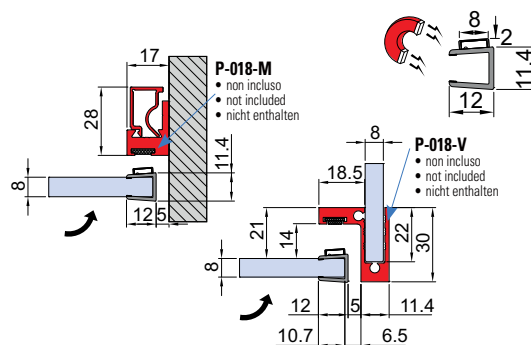
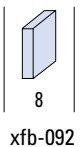
L=2500

BX.413

GUARNIZIONI GASKETS / DICHTUNGEN

- Alcune tipologie di applicazione
- Some application typologies
- Einigen kompositionsmöglichkeiten des system

- Doccia a battente ad angolo con vetro fisso.
- Angled shower cabin with swing door and fixed panel.
- Eck-Duschkabin mit Drehtür und Seitenteil.

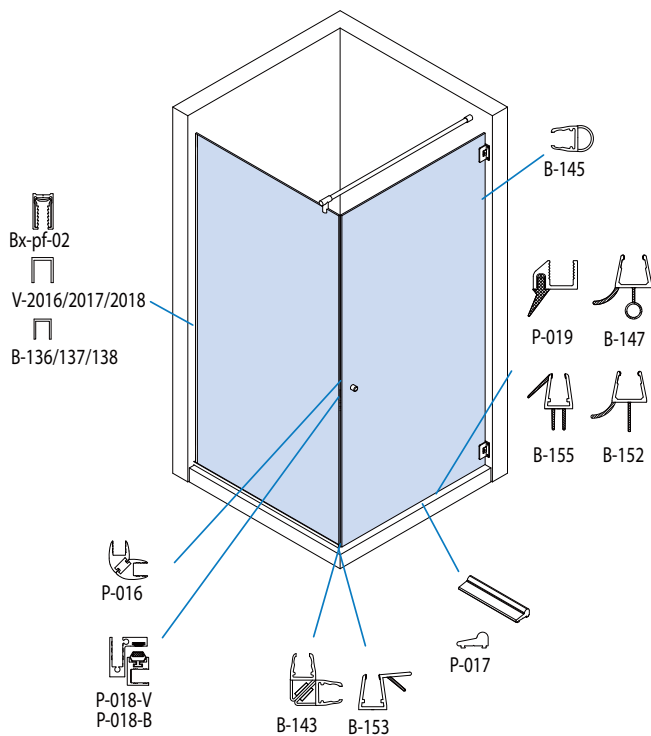

- Doccia scorrevole con vetri fissi laterali.
- Shower cabin with sliding door and fixed side panels.
- Duschkabin mit Schiebetür und Seitenteilen.

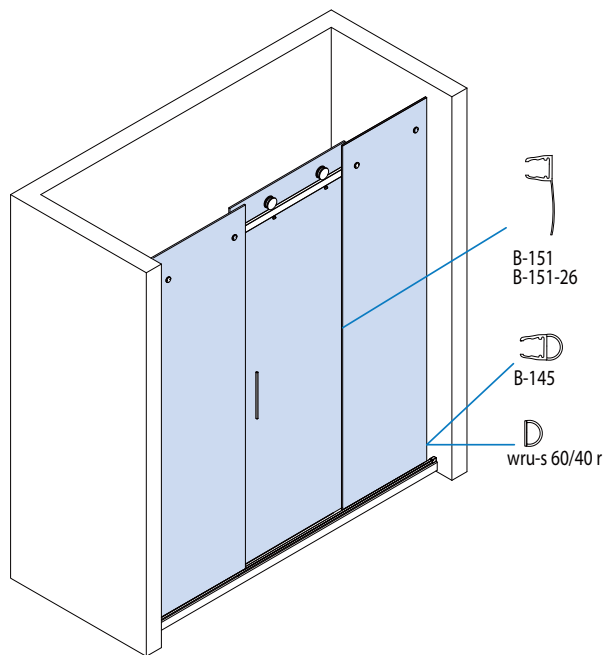

- Doccia a battente con vetri fissi laterali.
- Shower cabin with swing door and fixed side panels.
- Duschkabin mit Drehtür und Seitenteilen.

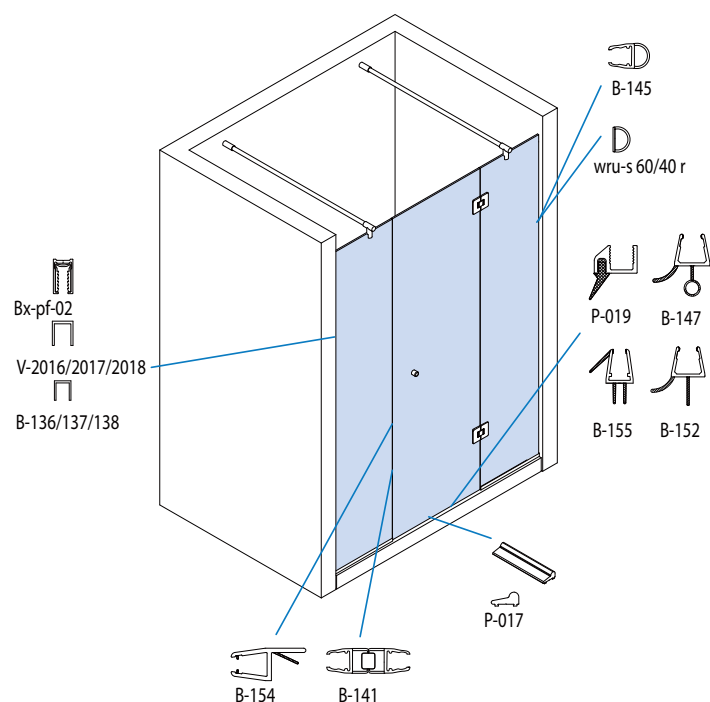

- Doccia a battente.
- Shower cabin with swing door.
- Duschkabin mit Drehtür.

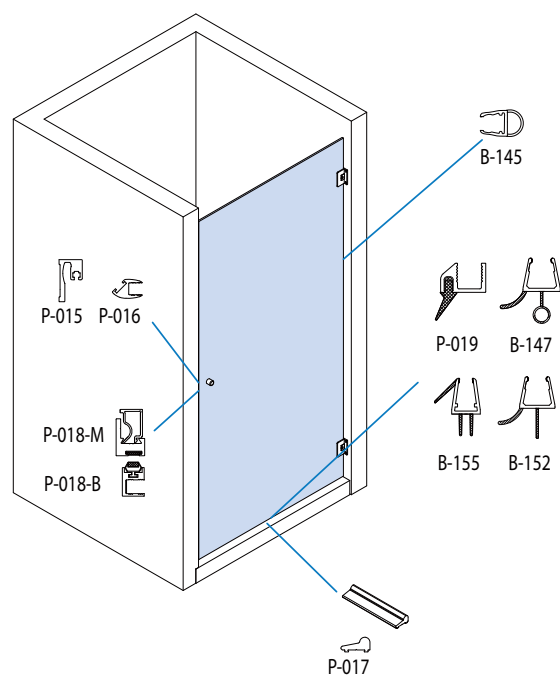

xme318

B-151-26

- Guarnizione per scorrevoli in PVC trasparente.
- Sliding doors seal transparent PVC.
- PVC Dichtprofil für Schiebetüren.

1 pcs L=2200

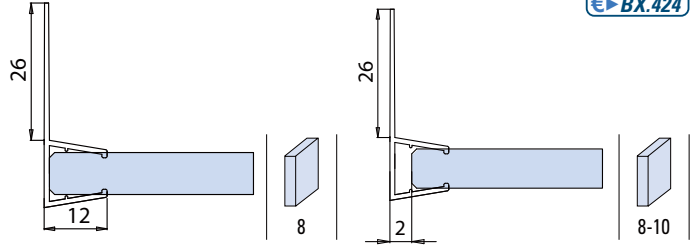

BX.424

xme390-B

B-151-20

- Guarnizione per scorrevoli in PVC trasparente.
- Sliding doors seal transparent PVC.
- PVC Dichtprofil für Schiebetüren.

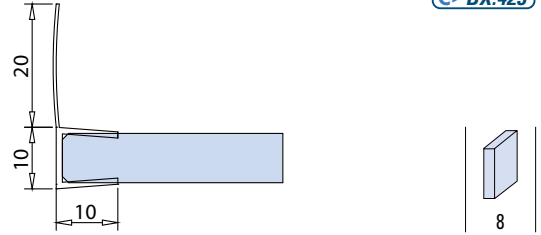
1 pcs L=2200



BX.423

xme390-C

B-141-8

- Guarnizione magnetica.
- Pvc magnetic seal.
- Pvc Magnetdichtung für Glas-Glas.

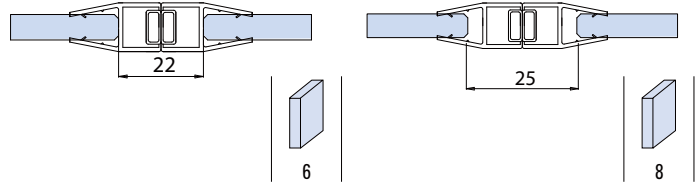
1 pcs L=2200



BX.415

xme390-B

B-141-10

- Guarnizione magnetica.
- Pvc magnetic seal.
- Pvc Magnetdichtung für Glas-Glas.

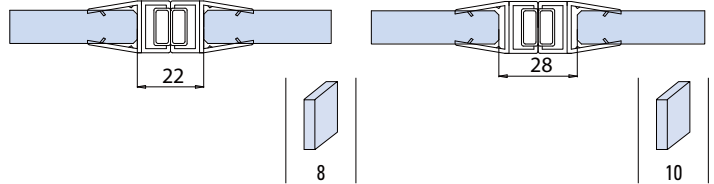
1 pcs L=2500



BX.416

xme390-B

B-143-8

- Guarnizione magnetica in PVC trasparente.
- PVC magnetic seal transparent PVC.
- PVC Magnetdichtung für Glas-Glas 90°.

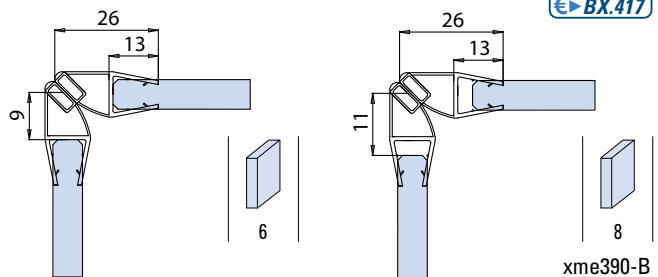
1 pcs L=2500



BX.417

xme390-B

B-143-10

- Guarnizione magnetica in PVC trasparente.
- PVC magnetic seal transparent PVC.
- PVC Magnetdichtung für Glas-Glas 90°.

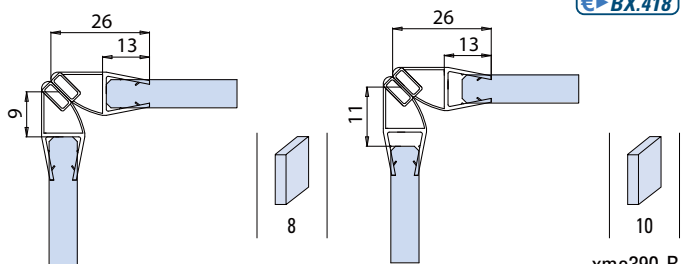
1 pcs L=2500

BX.418

xme390-B





B-145-8

- Guarnizione a palloncino vetro/muro in PVC trasparente.
- Glass to wall ball seal transparent PVC.
- PVC Dichtprofil Glas-Wand.

1 pcs L=2500

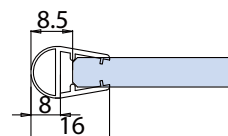
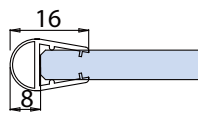

xme390-A

€ BX.419



B-145-10

- Guarnizione a palloncino vetro/muro in PVC trasparente.
- Glass to wall ball seal transparent PVC.
- PVC Dichtprofil Glas-Wand.

1 pcs L=2500

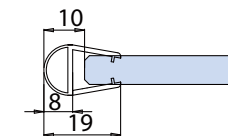
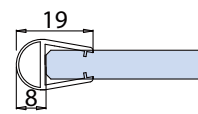

xme390-A

€ BX.420



B-147-8

- Guarnizione gocciolatoio in PVC trasparente.
- Drip flap seal transparent PVC.
- PVC Dichtprofil für den unteren Wannenanschluss.

1 pcs L=2200

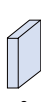
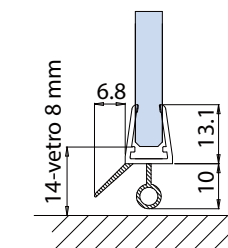
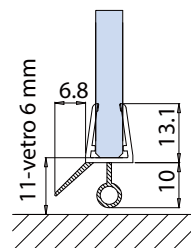

xme390-A

€ BX.425



B-147-10

- Guarnizione gocciolatoio in PVC trasparente.
- Drip flap seal transparent PVC.
- PVC Dichtprofil für den unteren Wannenanschluss.

1 pcs L=2200

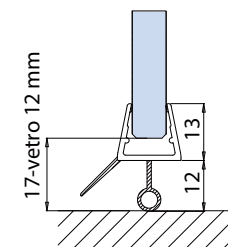
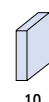
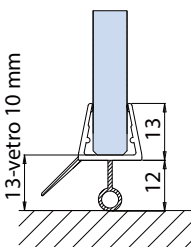

xme390-A

€ BX.426



B-149-8

- Guarnizione vetro/vetro in PVC trasparente.
- Door stop seal transparent PVC.
- PVC Dichtprofil für Glas-Glas 180°.

1 pcs L=2500

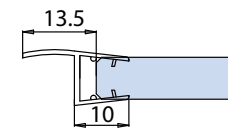
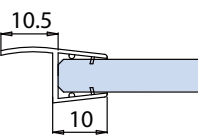

xme390-B

€ BX.421



B-149-10

- Guarnizione vetro/vetro in PVC trasparente.
- Door stop seal transparent PVC.
- PVC Dichtprofil für Glas-Glas 180°.

1 pcs L=2500

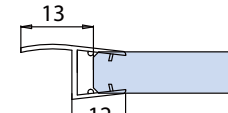
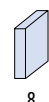
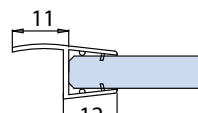

xme390-B

€ BX.422

B-152-MIX

- Guarnizione gocciolatoio in PVC trasparente.
- Drip flap seal in transparent PVC.
- PVC Dichtprofil für den unteren Wannenanschluss, für 8 und 10 mm Glas.

1 pcs L=2200

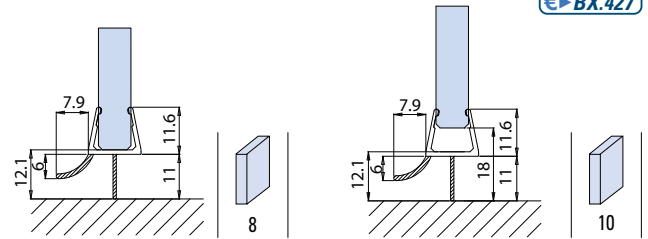

xme390-B



B-153-MIX

- Guarnizione a battuta in PVC trasparente.
- Seal profile glass-glass 90° with door stop in transparent PVC.
- PVC Dichtprofil glass-glass 90° mit Türanschlag, für 6 und 8 mm Glas.

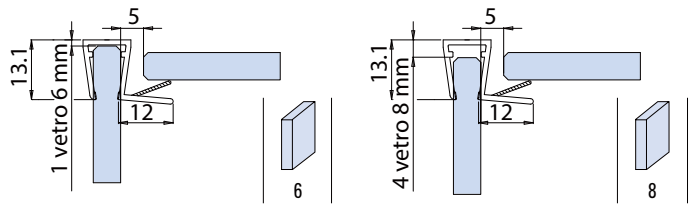
1 pcs L=2200

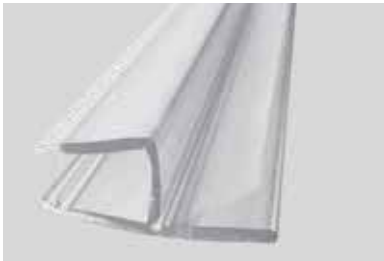

xme390-A

B-154-MIX

- Guarnizione "H" a battuta in PVC trasparente.
- Seal profile glass-glass 90° with door stop in transparent PVC.
- PVC Dichtprofil glass-glass 180° mit Türanschlag.

1 pcs L=2200

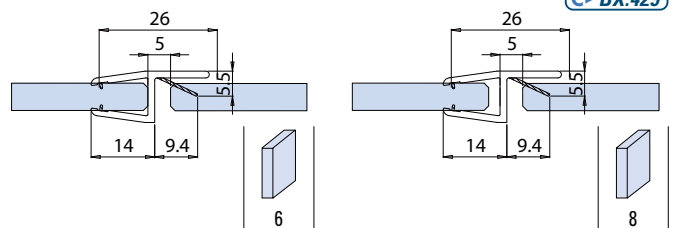

xme390-B

B-155-MIX

- Guarnizione con diga e deflettore in PVC trasparente.
- Drip flap seal in transparent PVC.
- PVC Dichtprofil für den unteren Wannenanschluss.

1 pcs L=2200

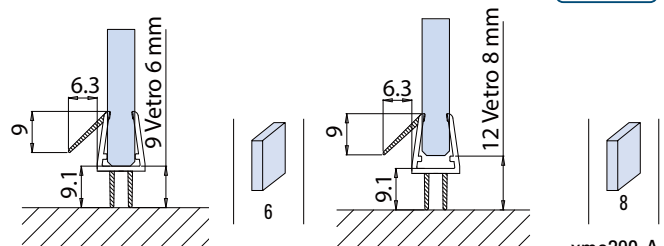

xme390-A

WRU-C-BUMP-MT12

- Guarnizione neutra per vetro 8 mm, fissaggio adesivo
- Neutral gasket for glass 8 mm with adhesive fixing
- Dichtungsprofil für 8 mm. selbstklebend

12 m

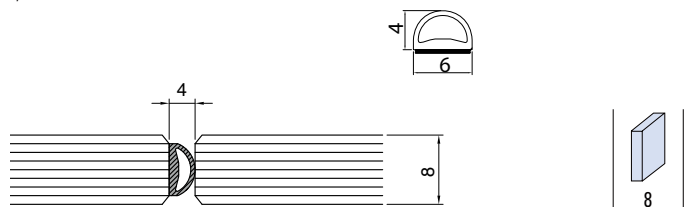

WRU-M 80/50

- Guarnizione neutra in PVC con fissaggio adesivo
- Neutral PVC gasket with adhesive fixing.
- Dichtungsprofil selbstklebend

5 mtl

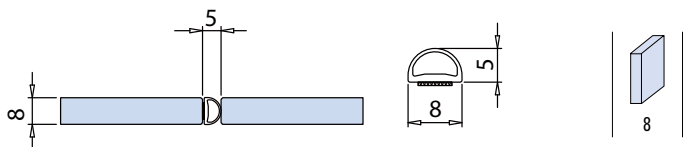

- Confezione mt. 5.
- Package unit of 5 mt.
- Verpackungseinheit von 5 lfm.

xfb-099

POMOLI, NICCHIE, MANIGLIONI KNOBS, SLIDING HANDLES, HANDLES / KNÖPFE, GRIFFMUSCHELN, STOSSGRIFFE



B-196

- Coppia pomoli 25 x 28 mm.
- Pair of doorknobs 25 x 28 mm.
- Paar Türknöpfe 25 x 28 mm.

CR - NS - NO

€ BX.340

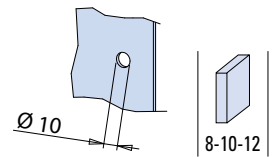
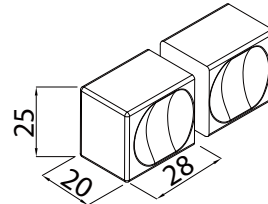

B-198

- Coppia pomoli 30 x 30 mm.
- Pair of doorknobs 30 x 30 mm.
- Paar Türknöpfe 30 x 30 mm.

CR - NS - NO

€ BX.341

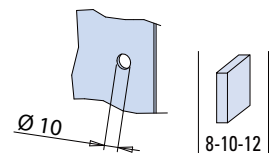
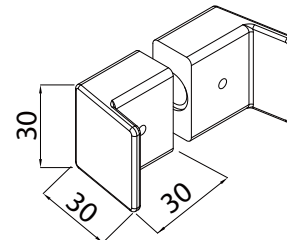
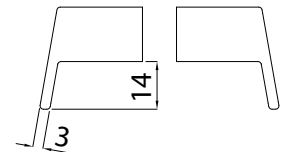

V-024 25

€ BX.342

- Coppia pomoli Ø 25 mm.
 - Pair of doorknobs Ø 25 mm.
 - Paar Türknöpfe Ø 25 mm.
- CR - NS

V-024 30

€ BX.343

- Coppia pomoli Ø 30 mm.
 - Pair of doorknobs Ø 30 mm.
 - Paar Türknöpfe Ø 30 mm.
- CR - NS - OR

V-024 32

€ BX.344

- Coppia pomoli Ø 32 mm.
 - Pair of doorknobs Ø 32 mm.
 - Paar Türknöpfe Ø 32 mm.
- CR - NS

V-024 38

€ BX.345

- Coppia pomoli Ø 38 mm.
 - Pair of doorknobs Ø 38 mm.
 - Paar Türknöpfe Ø 38 mm.
- CR - NS

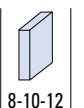
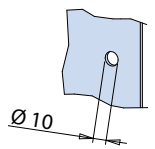
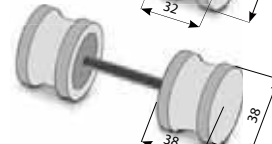
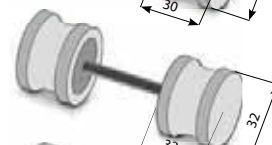
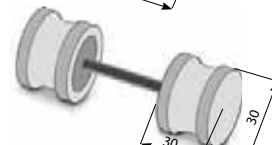
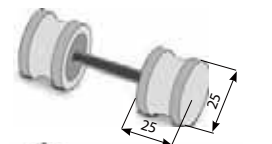

B-168

€ BX.346

- Pomolo per porte in Zama.
 - Glass doors knob Zamak.
 - Paar Türknöpfe aus Zamak.
- CR - NS - CP - NO

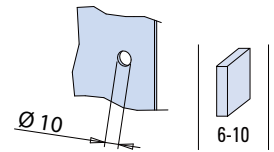
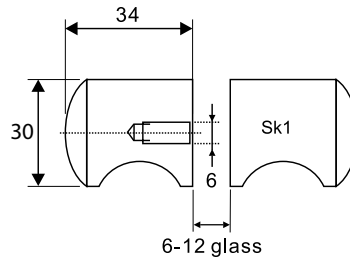
B-169

€ BX.347

- Coppia pomoli 28 x 28 mm.
 - Pair of doorknobs 28 x 28 mm.
 - Paar Türknöpfe 28 x 28 mm.
- CR

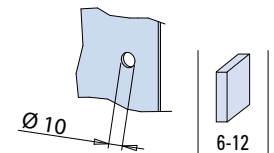
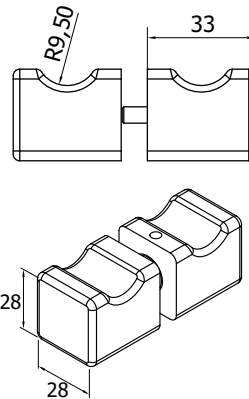
V-1107

€ BX.348

- Coppia pomoli 35 x 35 mm foro vetro Ø 10 mm
 - Pair of doorknobs 35 x 35 mm. Hole in glass 10 mm
 - Paar Türknöpfe 35 x 35 mm. Glas Bohrung 10 mm
- CR

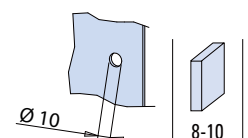

NS
Nickel satinato
Satin nickel
Ähnlich Edelstahl matt

CR
Cromo lucido
Polished chrome
Chrom glänzend

CS
Cromo satinato
Satin chrome
Chrom matt

CP
Cromo perla
Chrome perla similar Alu
Chrom perla ähnlich Alu

NO
Nero opaco
Matt black
Schwarz matt

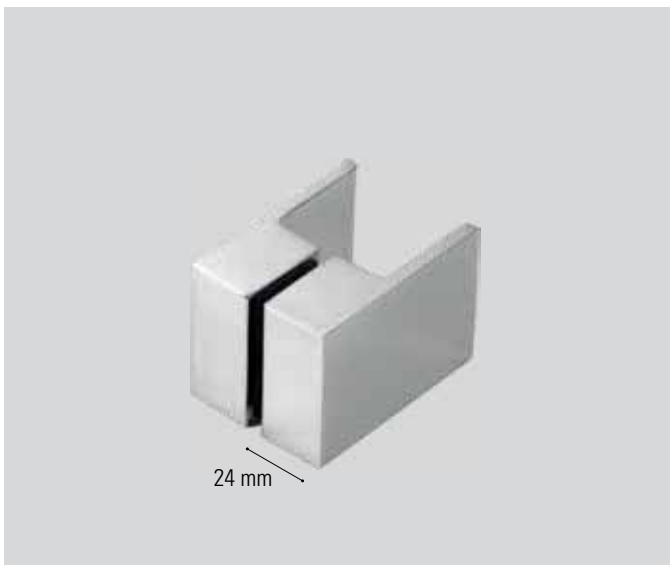

B-197

- Coppia pomoli 70 x 50 mm
 - Pair of doorknobs 70 x 50 mm
 - Paar Türknöpfe 70 x 50 mm
- CR

€ BX.349

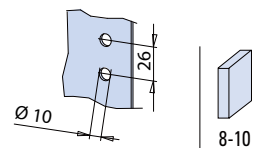

B-177

€ BX.350

- Paio pomolini tondi d. 15
- Pair mini knobs d. 15
- Paar mini knöpfe d. 15

IL - IX

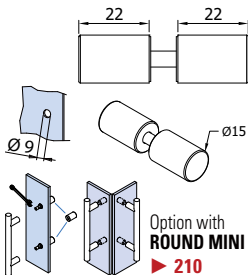

B-178

€ BX.351

- Paio pomolini quadri q. 15
- Pair mini knobs q. 15
- Paar knöpfe mini q.15

CR - NS

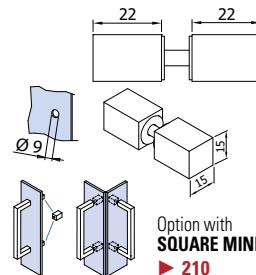

B-194

€ BX.352

- Coppia pomoli Ø 32 mm
- Foro vetro Ø 10 mm
- Pair of doorknobs Ø 32 mm
- Hole in glass 10 mm
- Paar Türknöpfe Ø 32 mm
- Glas Bohrung 10 mm

CR - NS

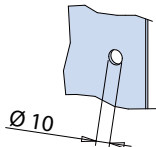

B-195

€ BX.353

- Coppia pomoli 25x25 mm
- Foro vetro Ø 10 mm
- Pair of doorknobs 25x25 mm
- Hole in glass 10 mm
- Paar Türknöpfe 25x25 mm
- Glas Bohrung 10 mm

CR - NS

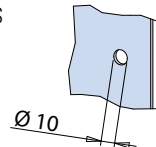

B-192

- Pomolo ad incollaggio biadesivo.
- Knob with self-adhesive fixing.
- Knopf selbstklebend.

CR

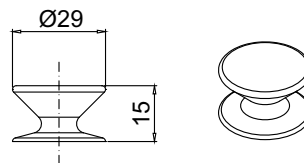

€ BX.354

xme311

V-019

- Coppia pomoli in vetro.
 - Pair of door knobs in glass.
 - Paar Türknöpfe aus Glas.
- NS + GLASS

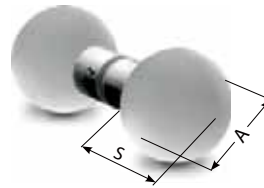

A = 40 / 45 / 50
S = 52 / 57 / 62

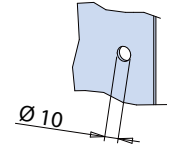
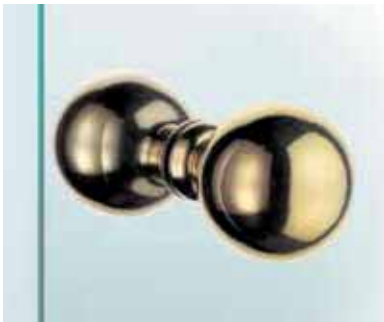

V-1056

- Coppia pomoli palla Ø 60 mm.
- Pair of door knobs Ø 60 mm.
- Paar Türknöpfe Ø 60 mm.

V-1056-2

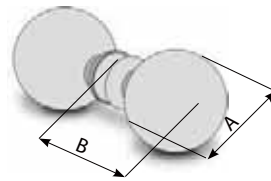
- Coppia pomoli palla Ø 50 mm.
 - Pair of door knobs Ø 50 mm.
 - Paar Türknöpfe Ø 50 mm.
- CS - NS - CR - OL - CP



Ø 60 A = 60 / B = 78
Ø 50 A = 50 / B = 70

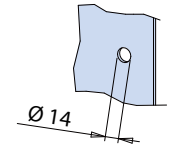

V-1105

- Coppia pomoli piatti Ø 55 mm.
 - Pair of doorknobs Ø 55 mm.
 - Paar Türknöpfe Ø 55 mm.
- CS - NS - CR - OL - CP

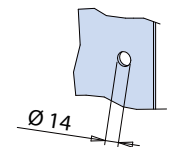
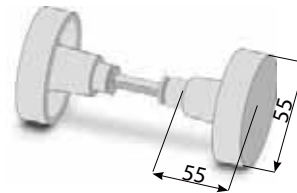

B-191-80 / B-191-240

- Maniglia ad incollaggio biadesivo.
- Small handle with self-adhesive fixing.
- Kleine griffe selbstklebend.

CR

		B-191-80	B-191-240
TL	80	•	
	240		•

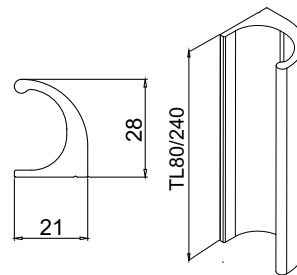

xme311

B-193

- Maniglia ad incollaggio biadesivo.
- Small handle with self-adhesive fixing.
- Kleine griffe selbstklebend.

CR

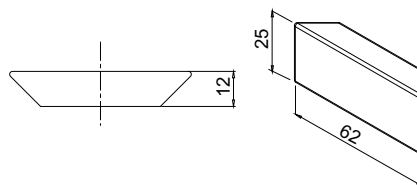

xme311

NS
Nickel satinato
Satin nickel
Ähnlich Edelstahl matt

CR
Cromo lucido
Polished chrome
Chrom glänzend

CS
Cromo satinato
Satin chrome
Chrom matt

OL
Ottone lucido
Polished brass
Messing poliert

CP
Cromo perla
Chrome perla similar Alu
Chrom perla ähnlich Alu



V-526

- Nicchia chiusa.
- Closed sliding-handle.
- Griffmuschel geschlossen.

AN - CR - NS - NO

€ BX.363

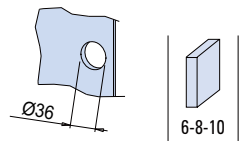
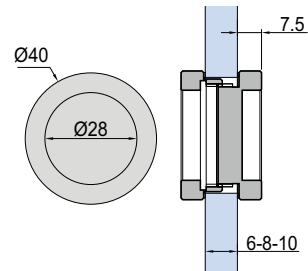

V-524

- Paio nicchie per scorrevole tonde, Ø 60
- Materiale: ottone

- Pair sliding door-handles, Ø 60
- Material: brass

- Paar Griffmuscheln, Ø 60
- Material: Messing

CP - NS - CR - NO

€ BX.364

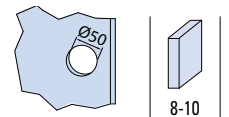
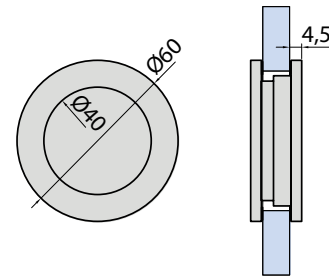

B-170

- Nicchia tonda Ø 55 mm per scorrevole.
- Foro nel vetro Ø 45 mm.
- Materiale: ottone

- Sliding door-handle round Ø 55 mm.
- Hole in glass Ø 45 mm.
- Material: brass

- Rund Griffmuschel Ø 55 mm.
- Glas Bohrung Ø 45 mm.
- Material: Messing

CR

€ BX.365

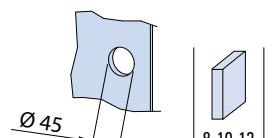
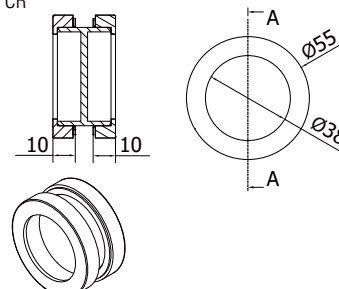

V-528

€ BX.366

- Nicchia chiusa.
 - Closed sliding-handle.
 - Griffmuschel geschlossen.
- AN - CR - NS

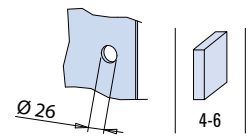
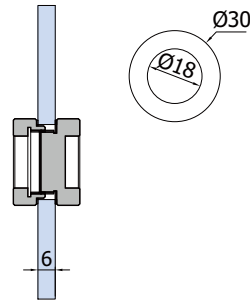
DIV-008

€ BX.367

- Paio nicchie scorrevole ad incollaggio
 - Pair sliding door-handles with self-adhesive fixing
 - Paar Griffmuscheln selbstklebend
- AN - NS - NO - BI - BC - BS - CR

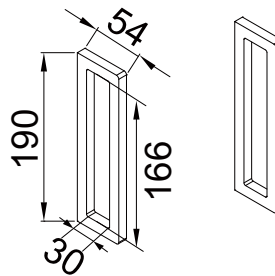

xme595m

DIV-007

€ BX.368

- Paio nicchie scorrevole ad incollaggio
 - Pair sliding door-handles with self-adhesive fixing
 - Paar Griffmuscheln selbstklebend
- AN - NS - NO - BI - BC - BS - CR

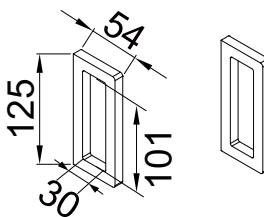

xme595m

NS
Nickel satinato
Satin nickel
Ähnlich Edelstahl matt

CR
Cromo lucido
Polished chrome
Chrom glänzend

CS
Cromo satinato
Satin chrome
Chrom matt

OL
Ottone lucido
Polished brass
Messing poliert

CP
Cromo perla
Chrome perla similar Alu
Chrom perla ähnlich Alu

AN
Alluminio anodizzato
Aluminium anodized
Aluminium Silberfarbig

NO
Nero opaco
Matt black
Schwarz matt

MANIGLIONI AD INCOLLAGGIO

PULLHANDLES WITH SELF-ADHESIVE / STOSSGRIFFE SELBSTKLEBEND

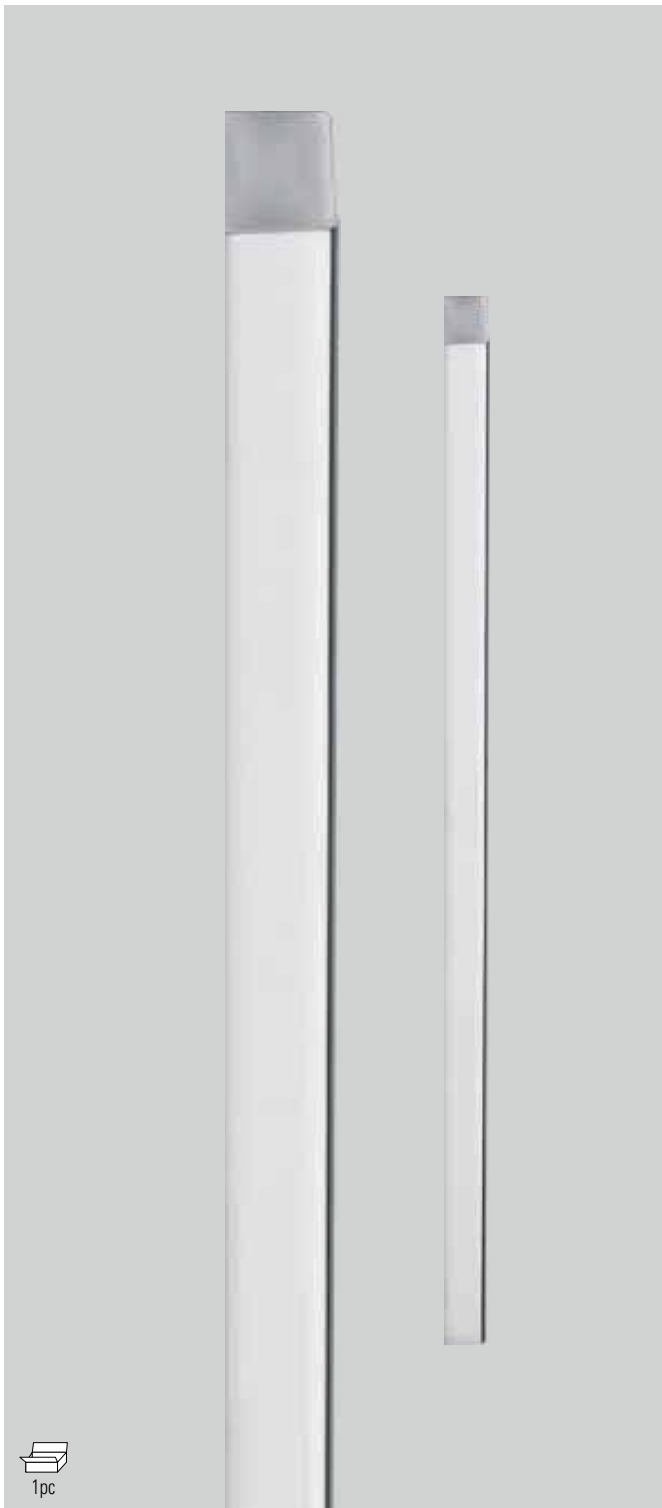

1 pc

SQUARE 10-INC

€ BX.370

☑	Code	TL	Materiale Material Material	Unit.	Finitura Finishes Oberfläche
	10.41.81/300	300	Alluminio Aluminium Aluminium	Singolo Piece Stück	AN
	10.41.51/300	300	Ottone Brass Messing	Singolo Piece Stück	CR
	10.41.61/300	300	Alluminio Aluminium Aluminium	Singolo Piece Stück	AL
	10.41.71/300	300	Alluminio Aluminium Aluminium	Singolo Piece Stück	NO
	10.41.81/500	500	Alluminio Aluminium Aluminium	Singolo Piece Stück	AN
	10.41.51/500	500	Ottone Brass Messing	Singolo Piece Stück	CR
	10.41.61/500	500	Alluminio Aluminium Aluminium	Singolo Piece Stück	AL
	10.41.71/500	500	Alluminio Aluminium Aluminium	Singolo Piece Stück	NO

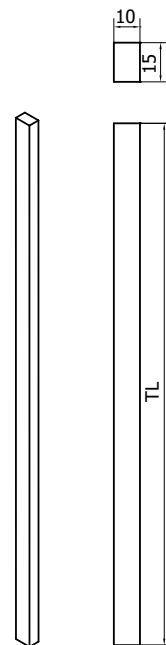

- Pulire con solvente
 - Clean with solvent
 - Mit Lösungsmittel reinigen



- Asciugare con un panno
 - Dry with a cloth
 - Mit einem Tuch trocknen



- Staccare la pellicola protettiva e applicare
 - Remove the protective film and apply
 - Die Schutzfolie abziehen und anbringen

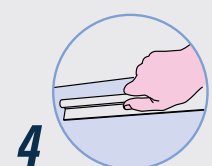

- Premere con forza
 - Press firmly
 - Fest drücken

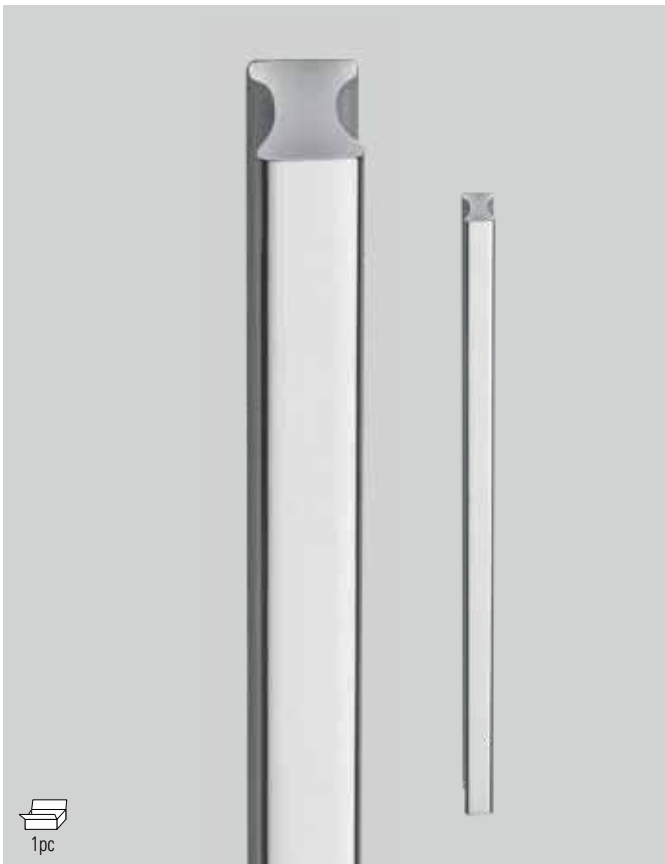

1pc

POR-0408 V

- Maniglione singolo con biadesivo
 - Pc pullhandle with self-adhesive fixing
 - Stück Stossgriff selbstklebend
- AN - IXO - NS - NO - BI - AL - CR

TL	C	Unit.	Finitura Finishes Oberfläche
260	17	Singolo Piece Stück	AL - AN - CR - IXO
410	17	Singolo Piece Stück	AL - AN - CR - IXO
560	17	Singolo Piece Stück	AL - AN - CR - IXO

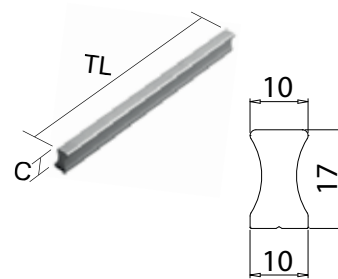

1pc

POR-0400 V

- Maniglione singolo con biadesivo
- Pc pullhandle with self-adhesive fixing
- Stück Stossgriff selbstklebend

TL	C	Unit.	Finitura Finishes Oberfläche
240	23	Singolo Piece Stück	AL - AN - CR - NS
390	23	Singolo Piece Stück	AL - AN - CR - NS
540	23	Singolo Piece Stück	AL - AN - CR - NS

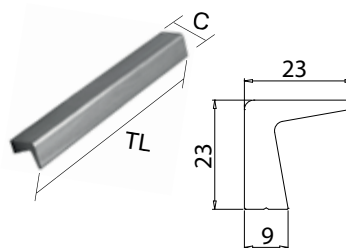

AL
Alluminio lucido
Polished aluminium
Aluminium glänzend

NS
Nickel satinato
Satin nickel
Ähnlich Edelstahl matt

CR
Cromo lucido
Polished chrome
Chrom glänzend

AN
Alluminio anodizzato
Aluminium anodized
Aluminium Silberfarbig

IXO
Effetto inox satinato
Inox effect
Inox effekt

NO
Nero opaco
Matt black
Schwarz matt

BI
Bianco opaco
Matt white
Weiss matt

MANIGLIONI MINI Ø 16 - Ø 15 / MANIGLIONI PULLHANDLES / STOSSGRIFFE

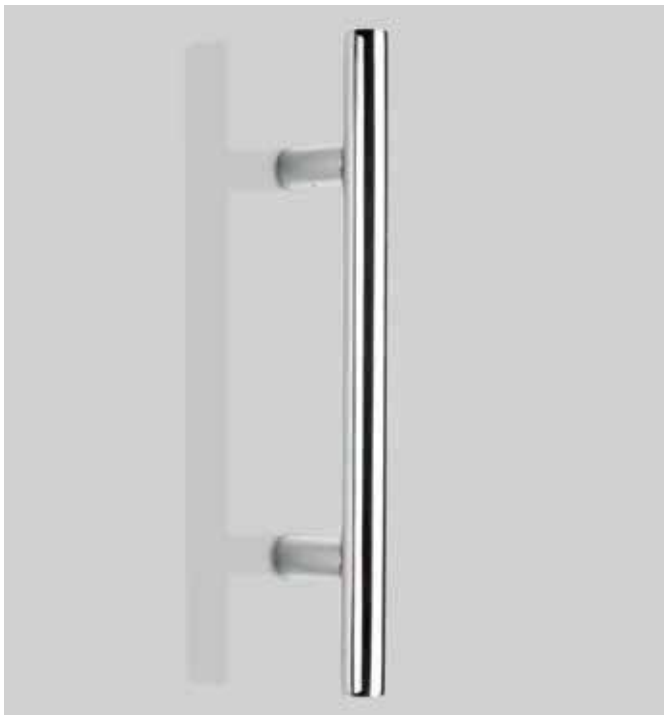

Round Mini Ø 16

- Paio maniglioni inox
 - Pair pullhandles inox
 - Paar Stossgriffe inox
- IX - IL

€►BX.373

	TL	225	300	
		135		Ø 9
A		200		Ø 9

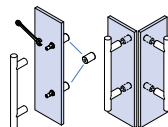
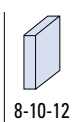
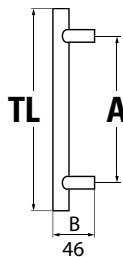

Option with
Knob **B-177**
page ► 204

€►BX.350



Square Mini Ø 15

- Paio maniglioni inox
 - Pair pullhandles inox
 - Paar Stossgriffe inox
- IX - IL

€►BX.375

	TL	150	215	315	
		135			Ø 9
A		200			Ø 9
			300		Ø 9

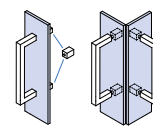
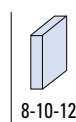
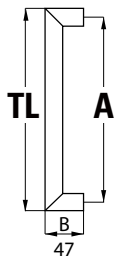

Option with
Knob **B-178**
page ► 204

€►BX.351

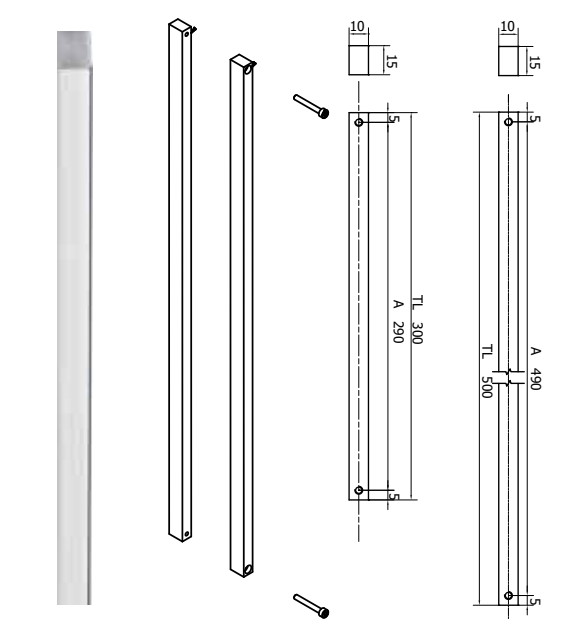

SQUARE 10

- Paio maniglioni
 - Pair pullhandles
 - Paar Stossgriffe
- AN - CR - NS

€►BX.377



Ø	Code	A	TL		Materiale Material Material	Unit.	Finitura Finishes Oberfläche
10 x 15	10.41.53/290.300	290	300	8	Ottone Brass Messing	Paio Pair Paar	CR
10 x 15	10.41.63/290.300	290	300	8	Alluminio Aluminium Aluminium	Paio Pair Paar	CR
10 x 15	10.41.73/290.300	290	300	8	Alluminio Aluminium Aluminium	Paio Pair Paar	NO
10 x 15	10.41.53/490.500	490	500	8	Ottone Brass Messing	Paio Pair Paar	CR
10 x 15	10.41.63/490.500	490	500	8	Alluminio Aluminium Aluminium	Paio Pair Paar	CR

Foro vetro
Glass hole
Glasbohrung

IX
Acciaio inox satinato
Satin stainless steel
Edelstahl matt

IL
Acciaio inox lucido
Polished stainless steel
Edelstahl poliert

MANIGLIONI \varnothing 15

PULLHANDLES / STOSSGRIFFE



SQUARE \varnothing 15

- Paio maniglioni. Materiale: Alluminio
 - Pair pullhandles. Material: Aluminium
 - Paar Stossgriffe. Material: Aluminium
- AN - AL - NS - NO

TL	174	206	334	
	•			\varnothing 11,5
A	192	•		\varnothing 11,5
			•	\varnothing 11,5

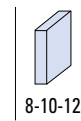

Foro vetro
Glass hole
Glasbohrung

AL
Alluminio lucido
Polished aluminium
Aluminium glänzend

NO
Nero opaco
Matt black
Schwarz matt

AN
Alluminio anodizzato
Aluminium anodized
Aluminium Silberfarbig

NS
Nickel satinato
Satin nickel
Ähnlich Edelstahl matt

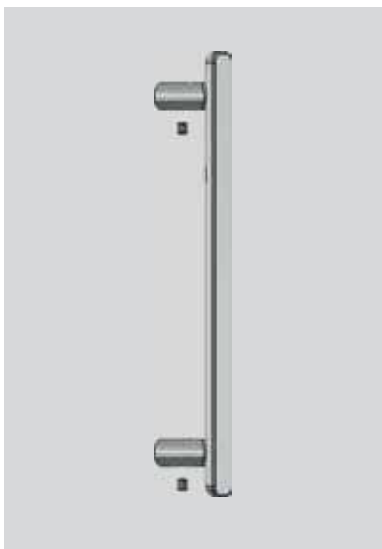

MANIGLIONI "ZAMA" PULLHANDLES ZAMAK / STOSSGRIFFE ZAMAK



SQ01 / SQ02

- Maniglione. Materiale: Zama
 - Pullhandle. Material: Zamak
 - Stossgriff. Material: Zamak
- CR

€► BX.378

Code	A	TL		
SQ01	160	200	M4	Ø 6
SQ02	160	200	M4	Ø 6

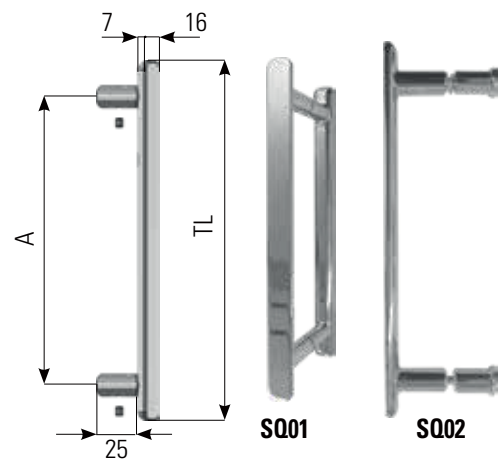

PORTASALVIETTE TOWEL BARS / HANDTUCHHALTER



B-120

- Portasalvietta montato a vetro L=600 mm, pomolino B-122 optional.
 - Glass mounted towel bar L=600 mm, knob B-122 optional.
 - Handtuchhalter für Glas L=600 mm, Knopf B-122 optional.
- CR

€► BX.379

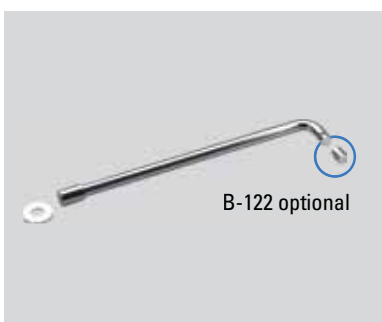
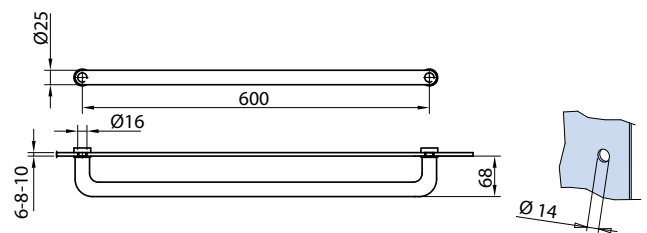

B-121

- Portasalvietta montato a vetro/muro L=600 mm, pomolino B-122 optional.
 - Glass/wall mounted towel bar L=600 mm, knob B-122 optional.
 - Handtuchhalter für Glas/Wand L=600 mm, Knopf B-122 optional.
- CR

€► BX.380

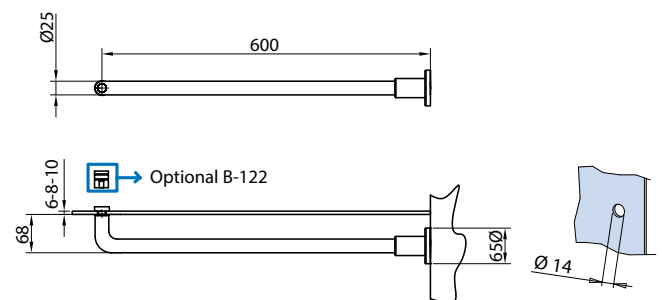

B-122

- Pomolo optional per portasalvietta.
 - Knob optional for towel bar.
 - Knopf optional für Handtuchhalter.
- CR

€► BX.381

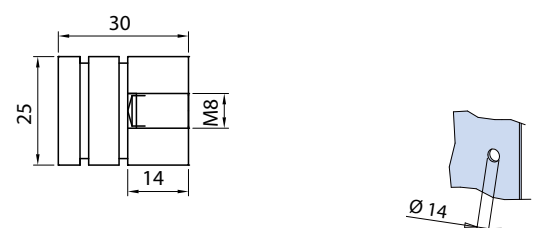

B-186

- Pomolo appendi salvietta montato a vetro.
- Knob towel bar for glass.
- Knopf Handtuchhalter, für Glas.

CR

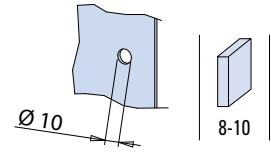
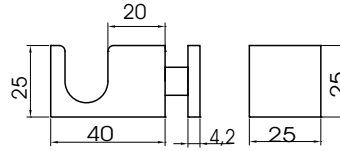
B-124

- Portasalvietta montato a vetro L-469 mm pomolino incluso.
- Glass mounted towel bar L-469 mm knob included
- Handtuchhalter für Glass L-469 mm Knopf enthalten

IL - NO

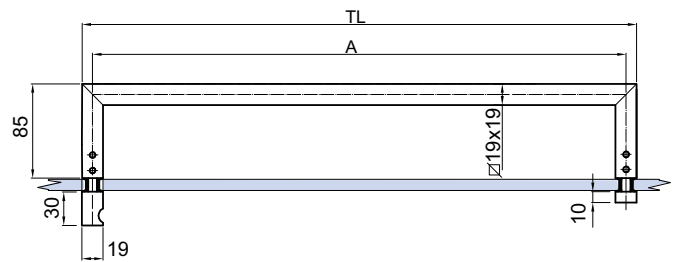
B-125

- Portasalvietta montato a vetro L-619 mm pomolino incluso.
- Glass mounted towel bar L-619 mm knob included
- Handtuchhalter für Glass L-619 mm Knopf enthalten

IL - NO



∅	Code	A	TL		Finitura Finishes Oberfläche	Materiale Material Material
19 x 19	B-124	450	469	10	IL - NO	Inox Stainless steel Edelstahl
19 x 19	B-125	600	619	10	IL - NO	Inox Stainless steel Edelstahl

PG-CHIAVE

- Chiave regolabile.
- Installation tool adjustable.
- Handwerkzeug Verstellbar.

 Foro vetro
Glass hole
Glasbohrung

IX
Acciaio inox satinato
Satin stainless steel
Edelstahl matt

CR
Cromo lucido
Polished chrome
Chrom glänzend

AN
Alluminio anodizzato
Aluminium anodized
Aluminium Silberfarbig

IL
Acciaio inox lucido
Polished stainless steel
Edelstahl poliert

NO
Nero opaco
Matt black
Schwarz matt

ALCUNE TIPOLOGIE DI APPLICAZIONE

SOME TYPOLOGIES OF APPLICATIONS

EINIGEN KOMPOSITIONSMÖGLIHEITEN DES SYSTEM





- Le informazioni tecniche in questo catalogo potrebbero non sempre corrispondere con gli attuali colori, misure e dimensioni. Noi perseguiamo una politica di costante innovazione e miglioramento e ci riserviamo il diritto di modificare specifiche e disponibilità senza preavviso. Non abbiamo nessuna responsabilità per errori di stampa che possono essere occorsi nella realizzazione di questo catalogo. Essendo questo solo un catalogo grafico per la foratura del vetro bisogna fare riferimento al manuale tecnico.
- Please note that the technical information included in this catalogue may not always precisely correspond with actual colours, measurements and dimensions. We pursue a policy of constant updating and improvement and reserve the right to alter specification and availability without notice. We take no responsibility for any printing errors that might be occurred in the completion of this catalogue.
- Die in diesem Katalog angegebenen Maße, Abbildungen und Angaben, sind unverbindlich. Modelländerungen, Konstruktionsverbesserungen und Maßänderungen behalten wir uns vor. Erfahrungsgemäss können Druckfarben nicht immer den Farbton original getreu wiedergeben. Farbabweichungen sind daher möglich. Für Druckfehler wie auch übrige Fehler welche bei Erstellung dieses Kataloges entstanden sind, ist jede Haftung ausgeschlossen.



METALGLAS BONOMI srl

Via Montini, 106/A - 25067 Lumezzane S.A. (Brescia) Italy
Ph. +39 030 829910 - Fax +39 030 8920970
www.metalglas.it - info@metalglas.it